

Evolution of cave living in Hawaiian *Schrankia* (Lepidoptera: Noctuidae) with description of a remarkable new cave species

MATTHEW J. MEDEIROS^{1*}, DON DAVIS², FRANCIS G. HOWARTH³ and ROSEMARY GILLESPIE⁴

¹Department of Integrative Biology, University of California, 3060 Valley Life Sciences Building, Berkeley, California 94720, USA

²Department of Entomology, Smithsonian Institution, National Museum of Natural History, 10th & Constitution NW, Washington, District of Columbia 20560, USA

³Department of Natural Sciences, Bishop Museum, 1525 Bernice Street, Honolulu, Hawaii 96817, USA

⁴Department of Environmental Science, Policy & Management, Division of Organisms and Environment, 137 Mulford Hall MC 3114, University of California, Berkeley, California 94720, USA

Received 13 March 2008; accepted for publication 12 May 2008

Although temperate cave-adapted fauna may evolve as a result of climatic change, tropical cave dwellers probably colonize caves through adaptive shifts to exploit new resources. The founding populations may have traits that make colonization of underground spaces even more likely. To investigate the process of cave adaptation and the number of times that flightlessness has evolved in a group of reportedly flightless Hawaiian cave moths, we tested the flight ability of 54 *Schrankia* individuals from seven caves on two islands. Several caves on one island were sampled because separate caves could have been colonized by underground connections after flightlessness had already evolved. A phylogeny based on approximately 1500 bp of mtDNA and nDNA showed that *Schrankia howarthi* sp. nov. invaded caves on two islands, Maui and Hawaii. Cave-adapted adults are not consistently flightless but instead are polymorphic for flight ability. Although the new species appears well suited to underground living, some individuals were found living above ground as well. These individuals, which are capable of flight, suggest that this normally cave-limited species is able to colonize other, geographically separated caves via above-ground dispersal. This is the first example of an apparently cave-adapted species that occurs in caves on two separate Hawaiian islands. A revision of the other Hawaiian *Schrankia* is presented, revealing that *Schrankia simplex*, *Schrankia oxygramma*, *Schrankia sarothrura*, and *Schrankia arrhecta* are all junior synonyms of *Schrankia altivolans*. © 2009 The Linnean Society of London, *Zoological Journal of the Linnean Society*, 2009, 156, 114–139.

ADDITIONAL KEYWORDS: adaptive shift – biogeography – exaptation – flightless – speleology – synonymy – troglobite.

INTRODUCTION

Caves offer biologists a natural laboratory for studying evolutionary change because the physical environment can be defined with great precision and because there is a clearly defined suite of characters that typically arise in cave animals, such as loss of pigmentation, reduction in the size of eyes, loss of wing area and flight ability, and elongated appendages

(Howarth, 1972). These changes may occur as a result of environmental conditions such as lack of predation, consistent availability of food, high levels of CO₂ and other gases, darkness, uneven terrain, and wet and humid conditions (Howarth, 1973, 1980, 1983, 1993; Roff, 1990). These character suites have evolved in caves throughout the world, allowing investigations of the strength of convergence or parallelism. However, comparative studies of convergent or parallel cave evolution require that the characters being examined evolved independently, and are thereby analogous. An

*Corresponding author. E-mail: m_j_m@berkeley.edu

understanding of the phylogenetic relationships of the taxa under study is therefore a prerequisite for this type of analysis (Roff, 1994).

Speciation among cave-dwelling species can result from isolation and divergence within or among cave systems, or between the surface and the cave. In the past, when studies were restricted to temperate limestone caves, troglobites (obligate cave-dwelling species) were considered relicts, their presence explained by the climatic relict hypothesis (CRH). This hypothesis proposed that cave populations of an ancestral species became isolated during periods of climatic change, particularly glaciation, which caused the extinction of surface populations. The ensuing isolation resulted in allopatric speciation coupled with cave adaptation (Barr, 1967, 1968; Sbordoni, 1982; Barr & Holsinger, 1985; Sbordoni, Allegrucci & Cesaroni, 2000). The CRH implies that cave invasion and subsequent adaptation are largely passive and driven by external factors – in many cases, climate change (Desutter-Grandcolas & Grandcolas, 1996).

More recently, with the discovery of troglobites in tropical areas that have never experienced glaciation, the adaptive shift hypothesis (ASH) was formulated by Howarth (1980, 1981, 1993). Here, surface populations are considered to have moved actively into caves, perhaps to exploit food resources. Once inside, these populations experienced a fundamentally different selective regime. Parapatric speciation, where the surface population does not become extinct, might occur even in the face of gene flow as a result of

strong disruptive selection (Howarth, 1987, 1993; Peck & Finston, 1993; Contreras-Díaz *et al.*, 2007).

Both the CRH and ASH recognize the importance of pre-existing adaptations of the ancestors of cave species that allowed them to colonize caves (Barr, 1968; Howarth, 1993). For some species, disruptive selection between surface and cave populations may not be strong, and the shift into caves may or may not be associated with speciation. In this hypothesis, speciation depends on the level of gene flow between cave and surface populations in relation to the level of disruptive selection (Arnedo *et al.*, 2007). From a phylogenetic perspective, these three scenarios lead to different patterns (Fig. 1). For morphologically similar species, the advent of molecular methods has allowed testing of these alternative hypotheses within a phylogenetic context, although considerable debate remains, especially with respect to the consequences that inadequate sampling or extinction may have on the observed phylogenetic patterns (Desutter-Grandcolas & Grandcolas, 1996; Rivera *et al.*, 2002).

The Hawaiian Islands present an excellent opportunity for examining these hypotheses of cave speciation, and the frequency and rate with which cave speciation may occur in an environment that has not been subject to glaciation. As on most oceanic islands, caves in the Hawaiian Islands are lava tubes formed through volcanic activity. Lava tubes form when the surfaces of rivers of molten lava solidify insulating the flowing lava beneath. When the lava subsequently drains or erodes deeper, a lava tube often remains

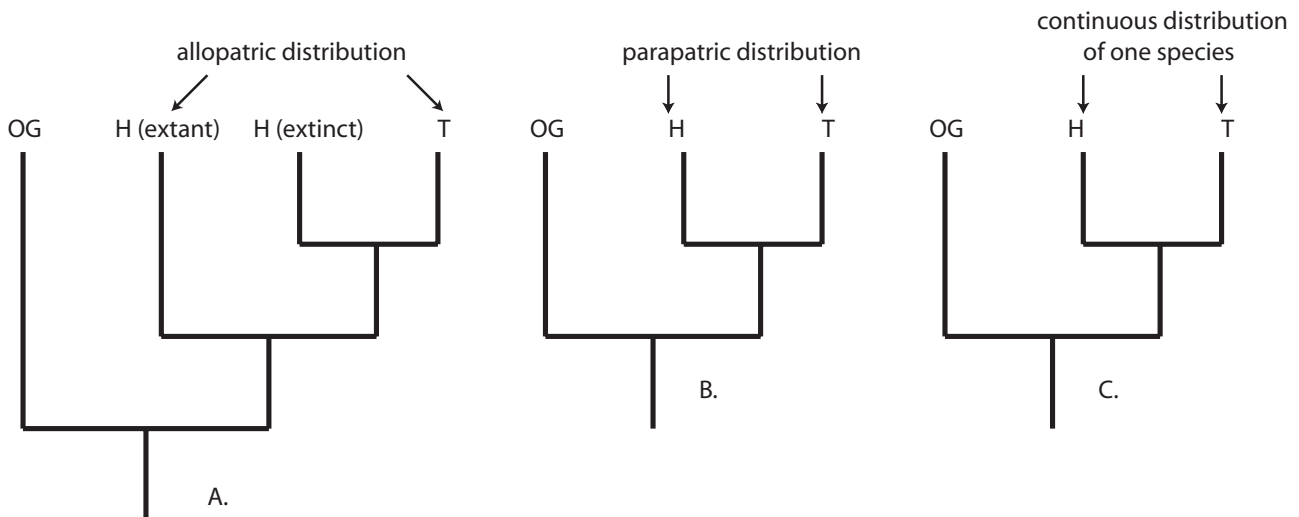

Figure 1. Phylogenetic patterns predicted by three hypotheses of cave colonization. A, climatic relict hypothesis (CRH): The hypogean sister species to the troglobite is extinct, and the next most related species has an allopatric distribution with the troglobite. B, adaptive shift hypothesis (ASH): The hypogean sister species, if extant, and the troglobite have a parapatric distribution. C, exaptation. Here, speciation has not occurred and populations of one species occur in both the hypogean and epigeal environments. OG, outgroup; H, hypogean species or population, T, troglobitic species or population.

(Peterson *et al.*, 1994). Terrestrial lava tube habitats are partitioned into zones based on the physical environment. The entrance zone represents the integration of surface and underground environment. The twilight zone extends from the limit of green plant growth to darkness. The transition zone includes cave passages in total darkness where climatic events on the surface are still felt. The deep zone is the area where the atmosphere remains relatively stable and saturated with water vapour. A few caves also have a stagnant air zone where air exchange with the surface is restricted and carbon dioxide accumulates. The boundaries between these zones are dynamic and often dictated by passage shape. Specialized cave animals are usually restricted to the two inner-most zones (Howarth, 1993).

A diverse assemblage of troglotic arthropods, including spiders, crickets, planthoppers, millipedes, and moths, can be found deep inside caves on several Hawaiian Islands (Howarth, 1987). Relationships amongst cave species on different islands have been the subject of considerable discussion: within any one island, lava tubes may be interconnected below ground, presenting an opportunity for underground dispersal of cave-living organisms, and close relationships among troglotic species in different caves may be explained either by underground dispersal to separate caves after adaptation to the hypogean (underground) environment, or by independent cave invasions. However, close affinities amongst cave-adapted species on different islands almost certainly have arisen from independent cave colonizations from surface forms (Rivera *et al.*, 2002), because troglotes typically die when exposed to surface conditions.

To date, two phylogeographical studies have attempted to determine the process of cave colonization in Hawaiian troglotes. Based on mitochondrial DNA and morphological evidence, Rivera *et al.* (2002) found that two genera of philosciid isopods have invaded caves, apparently independently, on different Hawaiian islands. One species, *Littorophiloscia* sp., occurs only on Hawaii Island, where it has a parapatric distribution with a surface ancestor which suggests a shift to cave life. The other genus, *Hawaiioscia*, is represented by four troglomorphic species inhabiting caves on each of four islands. No surface relative on the islands is known for this genus; however, the authors considered these species to have arisen through independent shifts from a widespread (but now extinct) ancestor. Hoch & Howarth (1999) examined seven species of *Oliarus* (Cixiidae) planthoppers from caves on three Hawaiian islands and, using morphological evidence, concluded that each of these species originated from surface relatives through independent shifts to cave systems. However, the overall paucity of studies that have provided

concrete evidence of independent shifts on different islands makes it impossible to gauge the generality and ubiquity of the phenomenon and, in particular, how suites of cave-associated characters may evolve in parallel.

The moth genus *Schrankia* (Lepidoptera: Noctuidae: Hypenodinae) is represented by five described epigeal (surface living) species (Zimmerman, 1958) and undescribed species from caves in both Maui and Hawaii islands. Besides being represented by both surface and cave-dwelling species, *Schrankia* individuals display readily observable suites of characters that appear to be associated with cave living, including flightlessness, loss of pigmentation, and reduction in eye size. Accordingly, the genus presents an ideal opportunity for testing the ASH and whether and how suites of characters may have evolved in parallel in caves on different islands. The Hawaiian representatives of this genus appear to be monophyletic, and probably became established in the Hawaiian Islands through colonization by the widespread and migratory *Schrankia costaeirigalis* Stephens (Holloway, 1977), perhaps from elsewhere in the Pacific region. On the surface, larvae of these moths probably feed on roots of trees. In the caves, adults and larvae typically live on the roots of plants (Fig. 2A) that grow above the surface of the cave, such as those of the 'ohi'a tree (*Metrosideros polymorpha*), which provide food for *Schrankia* larvae (Fig. 2B). *Schrankia* may also feed on the roots of alien species such as *Grevillea robusta* and *Eucalyptus tereticornis* (Howarth *et al.*, 2007). Two hypogean forms of *Schrankia* have been found in caves from both Maui and Hawaii Islands: a lightly pigmented, slightly reduced-wing form (Fig. 2C) that is predominantly found in the twilight zone of caves, and a very pale, apparently troglotic form (Fig. 2D) with reduced wings that is typically found in the dark zone. Some cave *Schrankia* females have the most reduced wings of any flightless Hawaiian moths other than *Thyrocopa apatela* Walsingham (Xylorictidae). Females from the troglotic morph are reportedly flightless (Howarth, 1983) on both islands, although this observation has not been systematically tested until now. The process of colonization of *Schrankia* into Hawaiian lava tubes is unknown. As with other hypogean arthropods in Hawaii, interisland dispersal seems unlikely to have occurred in cave *Schrankia*, especially because troglotic forms have quickly perished once brought outside caves (M.J. Medeiros, pers. observ.). Intra-island underground dispersal, however, may or may not be a mode of colonization of new caves for Hawaiian *Schrankia*.

The current study set out not only to determine the process of cave colonization in this group, but also, by focusing on flightlessness, to determine whether this possible cave adaptation evolved in parallel in



Figure 2. *Schrankia howarthi*, habitat, larval feeding and pupation sites. A, dense concentration of tree roots from ceiling of Pahoa Cave, Hawaii Island. B, larva feeding on root, Kazumura Cave, Hawaii Island. C, adult resting on pupal cocoon, Kaumana Cave, Hawaii Island, twilight zone. D, adult resting on pupal cocoon, Pahoa Cave, Hawaii I., dark zone.

separate caves. In particular, if flightless populations or species occurring in caves are more closely related to surface-living moths capable of flight than to other flightless cave species, and if flightlessness truly occurs in several populations or species of cave *Schrankia*, this would be a dramatic example of parallel evolution under very similar ecological conditions in fewer than 1 Myr, the maximum age of the island of Hawaii (Price & Clague, 2002). To determine whether *Schrankia* have invaded caves more than once we used phylogenetic methods from representatives of six caves on three separate volcanic massifs

on Hawaii Island and one cave on Maui. Therefore, even if intra-island underground dispersal accounts for the current distribution of cave *Schrankia* on Hawaii Island, we had the opportunity to provide some evidence that cave-adapted taxa cannot colonize caves on different islands.

MATERIAL AND METHODS

SPECIMEN SAMPLING

We collected epigeal *Schrankia* for phylogenetic analysis from four islands: Kauai, Oahu, Maui, and

Hawaii islands. Surface-living Hawaiian *Schrankia* were sometimes collected at a blacklight sheet; however, we found most adults by walking through forested areas with an insect net after sunset, capturing flying adults. For hypogean *Schrankia* we made extensive use of museum specimens, with additional specimens for phylogenetic analysis collected from six caves on Hawaii Island and one cave on Maui. We collected cave-dwelling *Schrankia* adults by searching the twilight and dark zones of each cave. Three outgroups were chosen for this study. *Hypena californica* Behr, a hypenine, was used to root the tree. The other two outgroups chosen were *S. costaestrigalis*, the probable sister to the Hawaiian *Schrankia*, as well as an undescribed *Schrankia* species from Tahiti.

TAXONOMY

We examined *Schrankia* specimens from the Bernice P. Bishop Museum (BPBM; Honolulu, Hawaii), the National Museum of Natural History (NMNH; Washington, D.C.), the Natural History Museum (BMNH; London, England), and from material collected by MJM (BPBM). When necessary, genitalia were prepared and mounted on slides using the following protocol: abdomens were soaked in simmering 10% KOH solution for one hour, genitalia were removed, stained with chlorazol black, spread on microscope slides, and mounted in either Canada balsam or Euparal (Bioquip, Rancho Dominguez, CA, USA). To determine species boundaries, we searched for suites of morphological characters that varied obviously and consistently amongst populations of moths from within and amongst islands. These characters are discussed in the individual species sections below.

FLIGHTLESSNESS – DROP TEST

In order to assess flight ability in twilight zone and dark zone morph *Schrankia*, all moths were subjected

to a drop test similar, but smaller in scale, to one used to determine gliding abilities in ants (Yanoviak, Dudley & Kaspari, 2005). We conducted this test inside lava tubes because hypogean *Schrankia*, particularly dark-zone morph individuals, died quickly upon being exposed to the hot, sunny conditions outside the caves during the day. First, an approximately 1-m high and 0.75-m diameter cylinder made of tarp with metal dowels and plastic tubing for support was erected inside the cave. Then, moths were held in a plastic vial above the centre of the cylinder and dropped by tipping the open vial upside down. The flight performance of the moth was qualitatively described as either quickly dropping to the bottom of the cylinder while beating its wings, slowly descending to the bottom or sides of the cylinder while beating its wings, or at any point ascending in elevation while beating its wings. Each moth was dropped five times in the same way. We considered a moth 'flightless' if it displayed no ascending flight during any of its five drop trials, regardless of whether it dropped straight down or slowly descended to the side of the chamber. We controlled for possible 'drop test effects' by dropping several epigeal *Schrankia* using the same method, outdoors at night. In each of these cases, the epigeal *Schrankia* were capable of ascending flight.

MOLECULAR METHODS

We included both dark-zone and twilight-zone cave moths, as well as surface moths with wing patterns similar to each of the five original Hawaiian *Schrankia* species in our phylogenetic analysis. We extracted DNA from one to three legs of recently killed specimens, which had been stored in 100% ethanol for between one month and two years, using Qiagen DNeasy Tissue Kits. Three primer pairs were used (Table 1) to sequence fragments of two mitochondrial genes, COI and COII, and fragments of a

Table 1. Primers used in this study

Gene	Primer name	Sequence (5' to 3')
COI*	C1-J-1751 (Ron)	GGATCACCTGATATAGCATTCCC
COI*	C1-N-2191 (Nancy)	CCCGGTAAAATTTAAAATATAAACTTC
COII†	C2-J-3291 (Strom)	TAATTTGAACTATYTTACCNGC
COII‡	C2-N-3778 (Eva-M)	ATTACTTGCTTTTCAGTCATCT
<i>Wingless</i> §	LEPWG1	GARTGYAARTGYCAYGGYATGTCTGG
<i>Wingless</i> §	LEPWG2	ACTICGCRCACCARTGGAATGTRCA

*Simon *et al.*, 1994.

†Brower, 1994.

‡Megens *et al.*, 2004.

§Brower & DeSalle, 1998.

nuclear gene, *wingless*, which has been proven useful in previous studies of closely related groups of Lepidoptera (Brower & DeSalle, 1998). To amplify both mitochondrial genes we used the following PCR protocol: 40 cycles of 95 °C (30 s) – 46 °C (45 s) – 72 °C (60 s). To amplify *wingless* we used the following protocol: 40 cycles of 95 °C (30 s) – 55 °C (30 s) – 72 °C (45 s). All PCR product was purified using ExoSapIt, cycle sequenced, and sequenced using an Applied Biosystems 3730 DNA Analyzer.

PHYLOGENETIC ANALYSIS

We aligned sequences using SEQUENCHER 4.6 (Genecodes Corporation, Ann Arbor, MI, USA) and used three methods to infer phylogenetic relationships: maximum likelihood, Bayesian inference, and maximum parsimony.

For all analyses, we combined the data from all three genes because when analysed individually, there were no nodes with > 50% bootstrap support that were incongruent amongst these datasets. However, this lack of supported incongruence was probably because of the small amount of among-site variation in the nuclear gene. For a group as closely related to each other as the Hawaiian *Schrankia*, nuclear genes appear not to evolve quickly enough to provide satisfactory resolution (see also Magnacca & Danforth, 2007). For example, in approximately 40 individuals for which we were able to sequence a fragment of the nuclear gene EF1 α , less than 1% of the characters were parsimony informative.

MODELTEST 3.7 (Posada & Crandall, 1998) was used to select the best model of molecular evolution. To determine the best models to use for each data partition, three partitions were tested: COI, COII, and *wingless*. Each of these partitions yielded the same best model, GTR+I+ Γ , which was then used for the combined data.

Maximum likelihood

We used the associated model parameters to analyse the data by maximum likelihood (heuristic search strategy with 10 000 random addition sequences) in PAUP* 4.0b10 (Swofford, 2002). To estimate node confidence, we used the GTRGAMMA model in RAxML 2.2.3 (Stamatakis, 2006) because it is a close approximation to our GTR+I+ Γ model of DNA sequence evolution. We performed 200 nonparametric bootstrap pseudoreplicates using RAxML.

Bayesian inference

We used MrBayes 3.1.1 (Ronquist & Huelsenbeck, 2003) with the GTR+I+ Γ model of DNA sequence evolution previously estimated using MODELTEST. Two runs were carried out, both based on a chain of

4×10^6 generations, with a tree sampled every 100 generations. A plot of tree likelihood vs. generation number reached stationarity after approximately 150 000 generations and we discarded the first 250 000 trees as 'burn-in'. We then computed a consensus tree with the remaining 3.75×10^6 trees and determined posterior probabilities for each clade based on the proportion of trees in which that particular clade occurred.

Maximum parsimony

Parsimony analysis was performed using a heuristic search, a MaxTrees limit of 10 000, and PAUP* default settings. We also searched for a most parsimonious tree using the PAUPrat algorithm (two searches were performed, one of 200 iterations and pct = 15; one with 300 iterations and pct = 25), which searches many tree islands quickly (Nixon, 1999; Sikes & Lewis, 2001). Using PAUP*, we performed 200 nonparametric bootstrap pseudoreplicates of the dataset in order to estimate node support.

RESULTS

TAXONOMY

In order to make the names available for the analyses reported herein, the Hawaiian *Schrankia* are here revised. The two species discussed below reflect two types of genitalic characters we found, as well as differences amongst individuals in wing pattern and size. Our taxonomic revision is based on these consistent morphological characters.

SCHRANKIA ALTIVOLANS (BUTLER)

Scoparia altivolans Butler, 1880: 9, in part.

Hypenodes altivolans (Butler). – Butler, 1881: 325, in part. – Meyrick, 1899: 155, 1904: 347, in part.

Schrankia altivolans (Butler). – Zimmerman, 1958: 413. – Poole, 1989: 898.

Hypenodes altivolans var. *simplex* Butler, 1881: 325, syn. nov.

Schrankia simplex (Butler); Zimmerman, 1958: 419. – Poole, 1989: 899.

Hypenodes oxygramma Meyrick, 1899: 154, pl. 4, fig. 14, syn. nov.

Schrankia oxygramma (Meyrick). – Zimmerman, 1958: 419. – Poole, 1989: 899.

Hypenodes sarothrura Meyrick, 1899: 155, 1904: 347, syn. nov.

Schrankia sarothrura (Meyrick). – Zimmerman, 1958: 419. – Poole, 1989: 899.

Hypenodes arrhecta Meyrick, 1904: 347, syn. nov.

Schrankia arrhecta (Meyrick). – Zimmerman, 1958: 417. – Poole, 1989: 898.

Schrankia altivolans is a predominantly epigeal Hawaiian species that closely resembles the following, *Schrankia howarthi*, in general morphology. However, although also possessing a relatively variable forewing pattern, adults of *S. altivolans* tend to exhibit a generally darker ground colour and larger size. The males may be distinguished from *S. howarthi* by the broader valva and more pronounced subapical constriction of the cucullus. Females of *S. altivolans* are distinguished by their more elongated ostium tube and ductus bursae.

Description

Adult (Fig. 3A–D): **Head:** Vestiture similar to *S. howarthi* except generally darker in colour, more fuscous. Antennal cilia of male between $\sim 1\times$ and $2\times$ diameter of flagellomere in length, that of female similar to that of *howarthi*. **Thorax:** Wing venation as shown (Fig. 4). **Forewing:** Length 6–10 mm; pattern variable, ground colour generally dark to light brown; median band variable, sinuate, sometimes black, white, or orange, and usually interrupted; reniform may be absent or present and black, if present, distal to medial band; antemedial line and postmedial lines sinuate, may be black, white, or orange, vary from strongly visible to indistinct, and are usually interrupted; subterminal line sinuate and pale, if present; black adterminal spots often present near ends of veins; fringe brown. **Hindwing:** uniformly pale brown to pale grey; base of fringe paler. **Abdomen:** uniformly pale brown to pale grey.

Male genitalia (Fig 5A, B): Similar to *S. howarthi* except cucullus of valva slightly broader and more abruptly narrowed near apex to form a uniformly slender apical lobe.

Female genitalia (Fig. 6A): Similar to *S. howarthi* except ductus bursae much longer than that of *S. howarthi*; length of ductus bursae $\sim 7\text{--}9\times$ the length of eighth segment; ostium tube also longer than that of *S. howarthi*, usually $\sim 1.0\text{--}1.2\times$ length of posterior apophyses. Swelling at juncture of ductus bursae with corpus bursae often pronounced.

Remarks: Previously described Hawaiian *Schrankia* were separated into five species by Meyrick (1899, 1904) and Zimmerman (1958); however, we could find no morphological characters that varied discretely or consistently in the specimens we examined. All characters, including length of male antennal cilia, thickness of ampulla in the male genitalia, and wing pattern, showed a continuum of variation, even within the type series. For example, the length of the antennal cilia in *S. altivolans* varies considerably, from $\sim 2\times$ to $\sim 1\times$ the diameter of flagellomere in

length. This observation, along with the lack of male genitalia in three of the five holotypes, and small amount of genetic divergence, renders recognizing individual epigeal Hawaiian *Schrankia* as more than a single species impossible. We have therefore synonymized four of the species under the senior name, *S. altivolans*. In his review of the Hawaiian *Schrankia*, Zimmerman (1958) wrote:

‘Although the male genitalia are complex organs, little differences have been found in them. It would appear that they should be expected to display excellent specific characters, but such, disappointingly, is not the case. Moreover, a considerable amount of individual variation has been found in the genitalia of both sexes, and this further compounds the confusion. This group appears to be yet another which is in the process of variation and species formation and clear-cut cleavage is not yet established.’

Zimmerman also wrote (1958) of *S. altivolans*, ‘This is an extremely variable species, and its true limits are not known.’

Type material examined: *Schrankia altivolans*, lectotype. – USA: HAWAII: 1 ♂, 1880, slide BMNH 1692 (BMNH), here designated. Paralectotype. – USA: HAWAII: 1 ♂, 1880, slide BMNH 1691 (BMNH).

Schrankia simplex, lectotype. – USA: HAWAII: 1 ♀, 1881 (BMNH), here designated. Paralectotypes. – USA: HAWAII: 1 ♂, 1 ♀, 1881 (BMNH). *Schrankia oxygramma*, holotype. – USA: HAWAII: Kauai Island: Koholuamano: ♀, iv.1895, slide BMNH 1702 (BMNH). *Schrankia sarothrura*, Holotype. – USA: HAWAII: Hawaii Island: Olaa: 1 ♂, vii.1895, slide BMNH 1690 (BMNH). *Schrankia arrhecta*, Lectotype. – USA: HAWAII: Kauai Island: 1219 m, 1 ♀, 1896, slide BMNH 1703, (BMNH). Paralectotype. – USA: HAWAII: Kauai Island: Mts. Waimea, 1219 m: 1 ♀, vi.1894, Perkins (BMNH).

Additional material examined: USA: HAWAII: 1 ♂, v.1896 (BMNH). Hawaii Island: Hawaii Volcanoes National Park: 1160 m: 1 ♂, 3 ♀, 13.viii.1977, F. G. Howarth (BPBM); Crater Rim Trail near Volcano House, 1189 m: 1 ♂, 23.iii.1979, G. K. Uchida (BPBM); Escape Road, 1128 m: 4 ♂, 5 ♀, 26.v.2006, slide and DNA 06A52, M. J. Medeiros (BPBM); Field Research Center: 1 ♀, 20.viii.1979, F. G. Howarth; 1 ♀, 20–21.viii.1979, F. G. Howarth (USNM); Kipuka Puauulu: 2 ♂, 27.v.2006, slide and DNA 06A70, M. J. Medeiros (BPBM); Napau Crater, 1 km south, 800 m: 1 ♂, 5 ♀, 22.viii.1979, F. G. Howarth (USNM); near Thurston Lava Tube, 1189 m: 1 ♀, 13.viii.1977, G. K. Uchida (BPBM); near Thurston Lava Tube, 1189 m: 1 ♀, 15.viii.1977, F. G. Howarth & G. K. Uchida (BPBM); near Thurston Lava Tube, 1189 m: 1 ♂, 3.i.1979, F. G. Howarth (BPBM); Puna, E. Rift, 730 m,

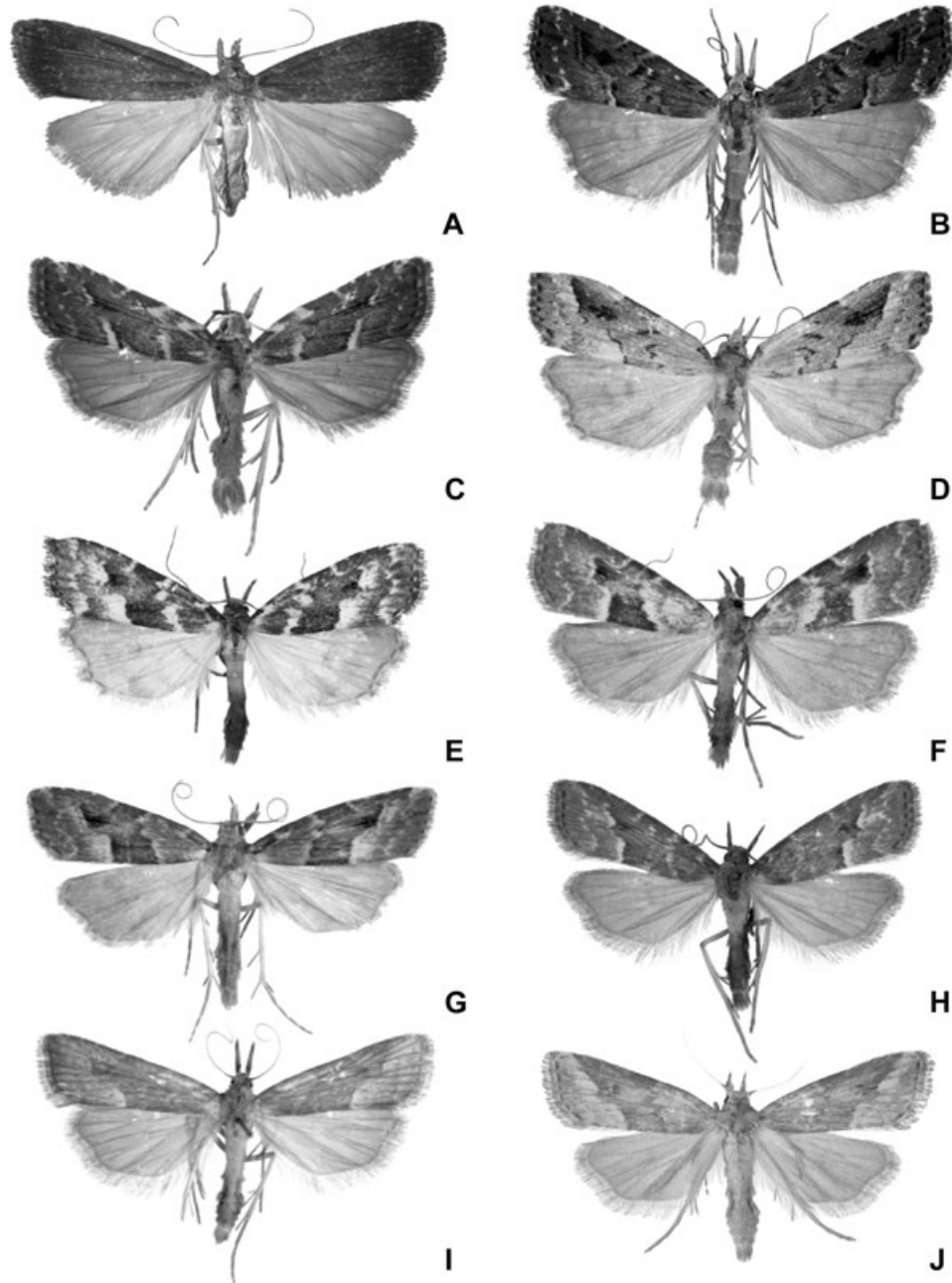

Figure 3. Hawaiian *Schrankia* adults. A, *Schrankia altivolans*, ♀, Upper Waiakea Forest Reserve, Stainback Highway, 930 m, on tree trunk, Hawaii Island (8.8 mm). B, *S. altivolans*, ♂, Aaa Kukai Cave, twilight zone, Hawaii Island (8.6 mm). C, *S. altivolans*, paratype ♂, Kaumana Cave, dark zone, Hawaii Island (5.5 mm). D, *S. altivolans*, ♂, Kealakekua Ranch Shelter Cave, twilight-dark zone, Hawaii Island (8.0 mm). E, *Schrankia howarhi*, paratype ♂, Kealakekua Ranch Shelter Cave, twilight zone, Hawaii Island (7.5 mm). F, *S. howarhi*, paratype ♂, Kealakekua Ranch Stone Wall Cave, twilight zone, Hawaii Island (6.5 mm). G, *S. howarhi*, paratype ♂, Kazumura Cave, dark zone, Hawaii Island (7.0 mm); H, *S. howarhi*, paratype ♂, Kealakekua Ranch Shelter Cave, dark zone, Hawaii Island (5.5 mm); I, *S. howarhi*, holotype ♂, Keauhou Ranch, Keamoku Cave, dark zone, Hawaii Island (5.8 mm). J, *S. howarhi*, paratype ♂, Ulupalakua Cave, dark zone, Maui Island (5.3 mm). Forewing lengths shown in parentheses.

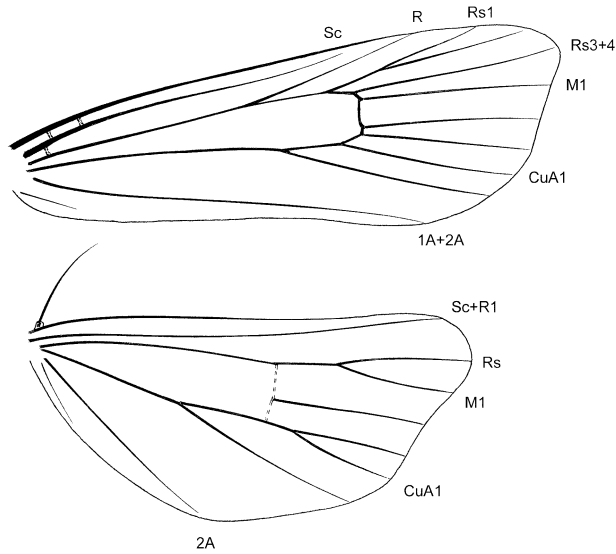

Figure 4. *Schrankia altivolans*, ♂, wing venation.

Boundary Puu: 2 ♂, 2 ♀, 7.ix.1977, F. G. Howarth (BPBM). Hilo, 610 m: 2 ♂, 3 ♀, xii.1895 (BMNH). Hilo, Puueo Point: 3 ♂, 2 ♀, 10–11.viii.1977, F. G. Howarth (USNM). Hilo, Puueo Point: 1 ♂, 8 ♀, 10–12.viii.1977, F. G. Howarth (BPBM). Honokaa Forest Reserve, Honokaa Cave, 610 m: 1 ♂, 25.iv.1972, F. G. Howarth (USNM). Kaumana, Kaumana Cave: 2 ♂, 26.iv.1972, D. R. Davis, slides 1632'1, 16462 (USNM); 290 m: 1 ♂, 26.ii.1980, slide USNM 33571; 1 ♂, 27.ii.1980, slide USNM 33624, F. G. Howarth (USNM); dark zone: 1 ♂, 30.x.1972, slide USNM 4328, F. G. Howarth (USNM). Kealakekua, Kealakekua Ranch, 1310 m: 1 ♂, 10.xii.1972, slide 33625 USNM, F. G. Howarth, W. C. Gagné, J. Jacobi (USNM). Keauhou, 600 m: 1 ♂, 7–8.vi.1969, B. Hocking (BPBM). Kilauea: 1 ♀, viii.1896, slide BMNH 1593 (BMNH). Kilauea: 2 ♂, 4 ♀, 12.viii.1958, J. W. Beardsley (BPBM). Kipuka Puaulu, Bird Park Cave, dark zone, 1250 m: 1 ♂, 6 Jul 1973, slide USNM 33088, F. G. Howarth (USNM). Kipuka Puaulu, Bird Park Cave #2, entrance, 220 m: 2 ♂, 29.vii.1976, F. G. Howarth (BPBM). Kipuka Puaulu, Bird Park Cave #3, twilight zone, 1250 m: 1 ♂, 3.iii.1973, F. G. Howarth (BPBM); twilight zone, 1250 m: 1 ♂, 3.iii.1973, F. G. Howarth & S. L. Montgomery (BPBM). Kohala Forest Reserve, White Road, 792 m: 2 ♂, 1 ♀, 30.v.2005, slides and DNA 05A68 & 05A69, M. J. Medeiros (BPBM). Kona, 1219 m: 1 ♀, 8.ix.1892, Perkins (BMNH). Manuka State Park, 400 m: 1 ♀, 12.vii.2004, slide and DNA 04A98, P. T. Oboyski (BPBM). Mauna Loa Bird Park, 1220 m: 1 ♂, 9–11.xii.1976, D. Davis & M. Davis (USNM). Mauna Loa Bird Park Cave #1, entrance, 1220 m: 3 ♂, 9.xii.1976, D. Davis & M. Davis (USNM). Mauna Loa Bird Park Cave #3, entrance, 1250 m: 2 ♂, 1 ♀,

9.xii.1976, D. Davis & M. Davis (USNM). Mauna Loa Strip Road, 2000 m: 6 ♂, 1 ♀, 5.vii.2004, slides and DNA 04A91 & 04A95, slides 04A94, 04A96 & 04A97, P. T. Oboyski (BPBM). Mauna Loa Strip Road, 2000 m: 2 ♂, 28.v.2006, slide and DNA 06A77, M. J. Medeiros (BPBM). Mountain View, Kazumura Cave, entrance sinkhole: 1 ♂, 8.xii.1976, F. G. Howarth, D. Davis, & M. Davis (USNM). Mountain View, Kazumura Cave, twilight zone, 400 m: 1 ♀, 11.iii.1973, F. G. Howarth (BPBM). Olaa, 610 m: 1 ♀, ix.1896 (BMNH). Olaa Forest Reserve, Wright Rd, 975 m: 1 ♂, 14.v.1978, emerged (em.) 1.vi.1978, W. P. Mull (BPBM). Puu Waawaa Forest Bird Sanctuary: 2 ♂, 5.vi.2007, M. J. Medeiros. Saddle Road & Tree Planting Road intersection, 1280 m: 2 ♀, 17.vii.2004, slide and DNA 04A49; 2 ♂, 2 ♀, 25.v.2006, slides and DNA 06A35 & 06A39, M. J. Medeiros (BPBM). Stainback Highway & Tree Planting Road intersection, 853 m: 4 ♂, 2 ♀, 18 Jul 2004, slides and DNA 04A54, 04A56 & 04A57; 2 ♂, 2 ♀, 25.v.2005, slide 05A24, M. J. Medeiros (BPBM). Two miles east of Pahoia, 145 m: 1 ♀, 7.ii.1987, K. Arakaki, W. Gagné, G. Nishida, & D. Preston (BPBM). Upper Waieka Forest Reserve, Stainback Highway, 930 m: 1 ♀, 27.vii.1976, F. G. Howarth (USNM). Volcano, 1160 m: 1 ♂, 6 ♀, 12–29.vii.1976, F. G. Howarth (BPBM). Volcano, 1160 m: 4 ♀, 23–26.ii.1980, F. G. Howarth (BPBM). Volcano, 1160 m: 1 ♂, 2.i.1979, F. G. Howarth & W. P. Mull (BPBM). Volcano, 1160 m: 1 ♂, 1 ♀, 9.ix.1979, S. L. Montgomery (BPBM). Volcano, 1220 m: 1 ♀, 10.xii.1976, D. Davis, M. Davis, & F. G. Howarth (USNM). Kauai Island: 1219 m: 2 ♀, .x.1895 (BMNH). Hanalei Ridge west-north-west of Waikoko Val. 125 m: 2 ♂, 2 ♀, 3.iii.2005, slide and DNA 05A03, P. T. Oboyski (BPBM). Koholuamano, 1219 m: 1 ♂, .iv.1895 (BMNH). Koholuamano, 1219 m: 1 ♀, .iv.1895, slide 1592 BMNH, Perkins (BMNH). Koholuamano, 1219 m: 1 ♂, iv.1896 (BMNH). Kokee: 3 ♀, 6–10.vii.1937, E.C. Zimmerman (BMNH). Kokee State Park, near Kahua Flat, 1202 m: 1 ♀, 27.ii.2005, P. T. Oboyski. Kokee State Park, Kalua-puhi Trail, 1219 m: 4 ♂, 3 ♀, 1–4.vi.2005, slides 05A73, 05A90 & 05A94, slides and DNA 05A77, 05A78 & 05A92; 1 ♂, 24.v.2007, M. J. Medeiros (BPBM). Kokee State Park, near Pihea Trailhead, 1158 m: 2 ♀, 27.v.2007, M. J. Medeiros. Kokee State Park, near 17 mile marker of park road: 1 ♂, 1 ♀, 2.vi.2005, M. J. Medeiros. Waimea Mtns, 914 m: 1 ♂, v.1894, Perkins (BMNH). Waimea Mtns, 1219 m: 1 ♂, 1 ♀, v.1894, Perkins (BMNH). Waimea Mtns, 1219 m: 1 ♀, v.1894, slide 1594 BMNH, Perkins (BMNH). Maui Island: E. Maui, Hana, twilight zone, Offal Cave, 90 m: 3 ♂, 26.viii.1977, F. G. Howarth & G. K. Uchida (BPBM); 1 ♂, 26.viii.1977, slide USNM 32928, F. G. Howarth & G. K. Uchida (USNM); 1 ♂, 26.viii.1977, slide USNM 32928, F. G. Howarth & G. K. Uchida

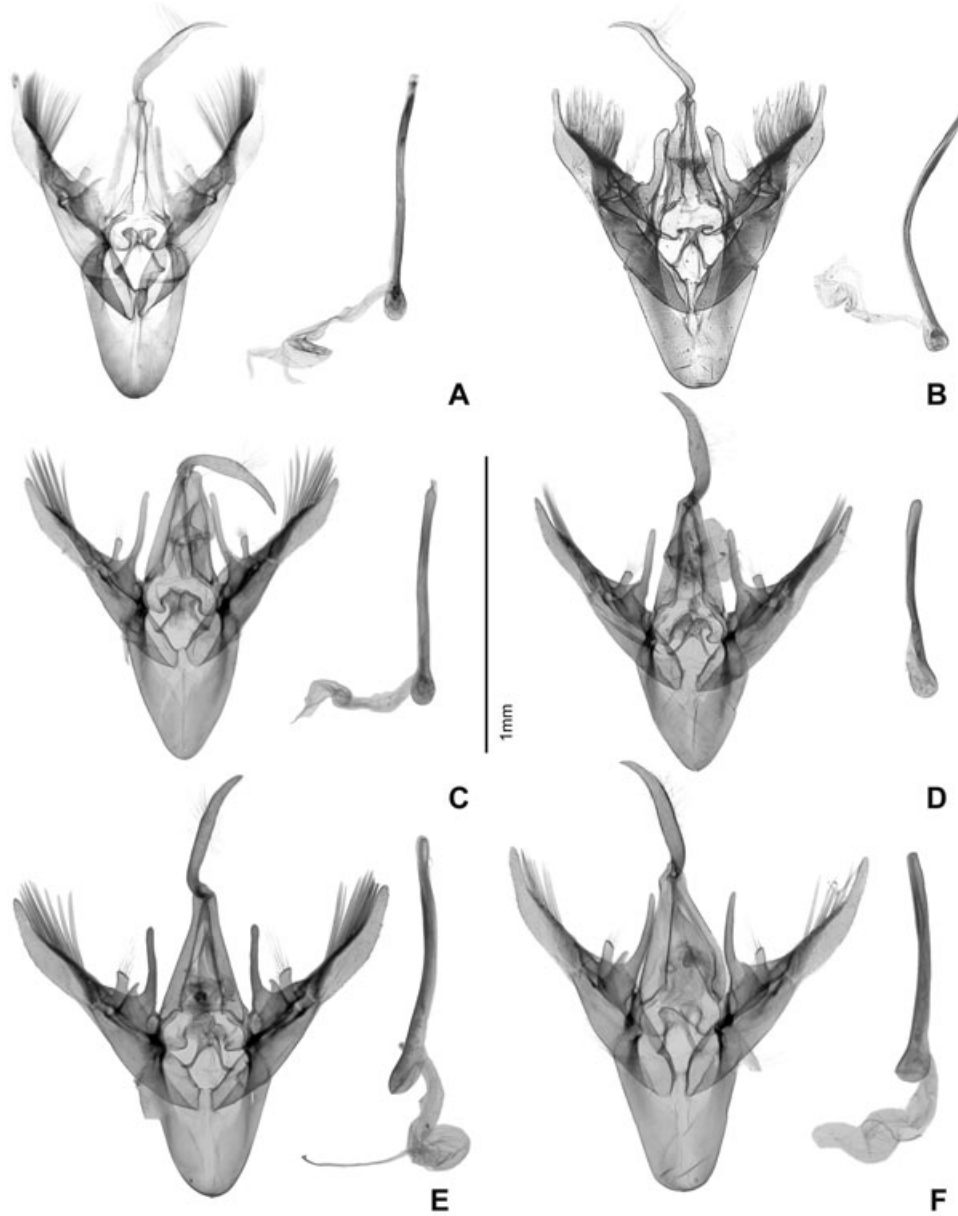

Figure 5. *Schrankia* ♂ genitalia. A, *Schrankia altivolans*, slide 04a78, Maui Island: Haleakala National Park, Hosmer Grove; B, *S. altivolans*, slide 33088, Hawaii Island: Bird Park Cave; C, *Schrankia howarthi*, slide 33081, Hawaii Island: Kazumura Cave; D, *S. howarthi*, slide 33082, Hawaii Island: Keamoku Cave; E, *S. howarthi*, slide 4327, Hawaii Island: Stonewall Cave; F, *S. howarthi*, slide 32929, Maui Island: Ulupalakua Cave.

(USNM). E. Maui, Koolau Forest Reserve, Waikamoi Flume Trail, 1300 m: 2 ♂, 24.viii.1977, F. G. Howarth & G. K. Uchida (USNM). E. Maui, Koolau Forest Reserve, Waikamoi Flume Trail, 1300 m: 1 ♀, 24.viii.1977, F. G. Howarth & G. K. Uchida (BPBM). E. Maui, Upper Hana Forest Reserve, 1675 m: near Mid Camp Aaa Kukai Cave twilight: 1 ♂, 5.viii.1973, slide 16951 USNM, F. G. Howarth (USNM); near Mid Camp Trapline Cave twilight: 1 ♂, 5.viii.1973, F. G. Howarth (USNM). Haleakala National Park, Holua

Cabin: 1 ♂, 29.vii.2004, slide and DNA 04A86, M. J. Medeiros (BPBM). Haleakala National Park, Hosmer Grove: 5 ♂, 3 ♀, 23.vii.2004, slides and DNA, 04A69, 04A71, 04A78 & 06B59, slides and DNA, 04A70, 04A73; 2 ♂, 18.ix.2006, M. J. Medeiros (BPBM). Haleakala National Park, near Hosmer Grove, 2075 m: 1 ♀, 17.vi.1976, F. G. Howarth (BPBM). Kula, 975 m: 1 ♀, 28.xii.2003, slide 03A17; 2 ♀, 14.vii.2004, slides and DNA 04A26 & 04A27; 2 ♀, 4.vi.2006, M. J. Medeiros (BPBM). Makawao Forest Reserve, 1280 m: 2 ♂, 8 ♀,

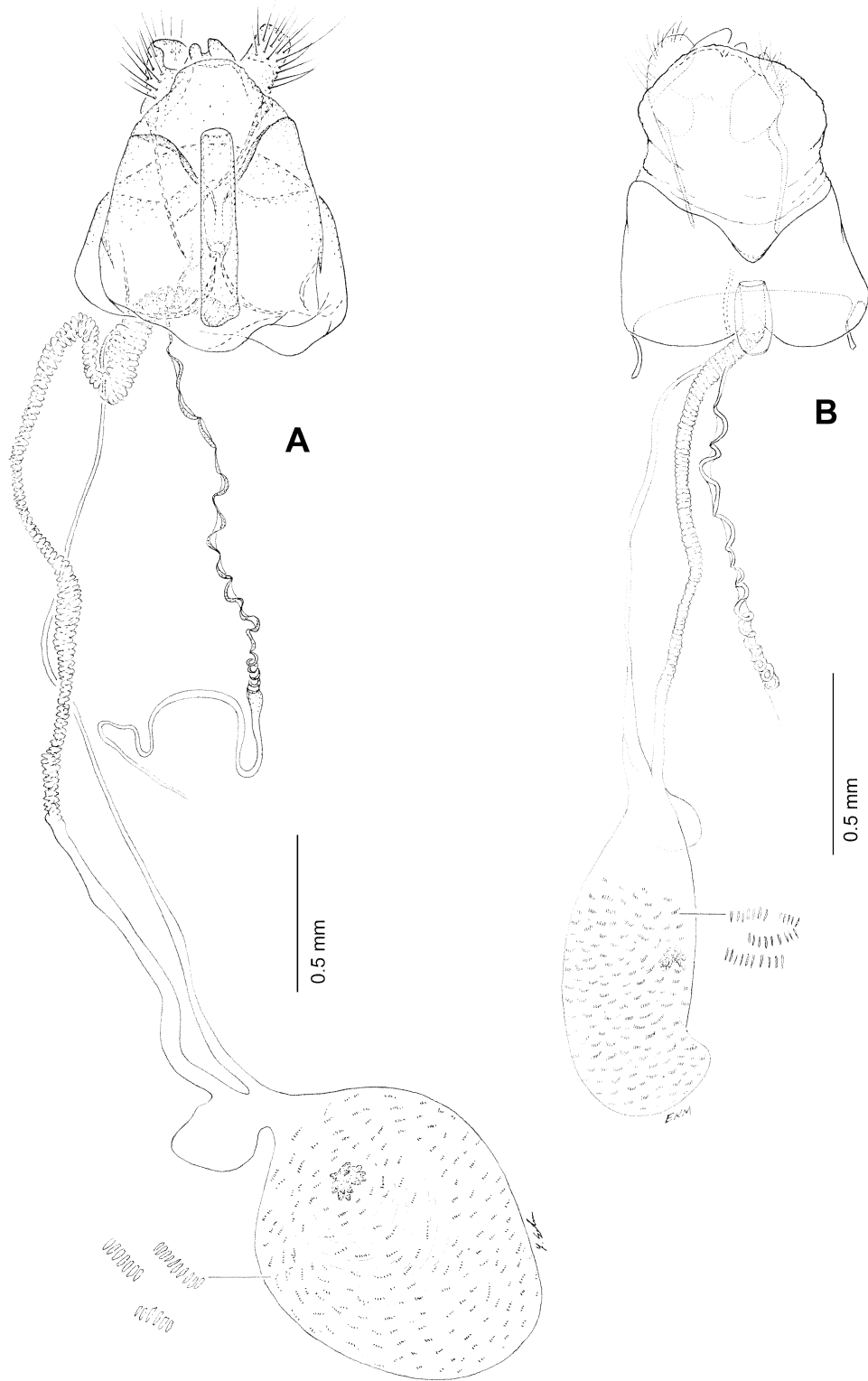

Figure 6. *Schrankia* ♀ genitalia. A, *Schrankia altivolans*, slide 33867, Hawaii Island: Hawaii Volcanoes National Park, Field Research Center; B, *Schrankia howarthi*, slide 17505, Hawaii Island: Kealakekua Ranch Shelter Cave.

23.v.–3.vii.2006, slide and DNA 06B09, slide 06B27, DNA 06B12, M. J. Medeiros (BPBM). Paliku, Haleakala Crater, 1945 m: 2 ♂, 22.vi.1976, F. G. Howarth (BPBM). Puu Kukui Trail, Haela'au, 914 m: 5 ♂, 6 ♀, 5.vi.2006, slides and DNA 06B45, 06B46, & 06B55, slide 06B43, M. J. Medeiros (BPBM). W. Maui, Kaulalewelewe, Puu Kukui Trail, 910 m: 1 ♂, 3 ♀, 22–23.viii.1977, F. G. Howarth & G. K. Uchida (BPBM); 1 ♂ 22–23.viii.1977, F. G. Howarth & G. K. Uchida (USNM). W. Maui, Puu Kukui Trail, Haela'au Cabin, 290 m: 1 ♀, 18.v.1974, F. G. Howarth (USNM). Molokai Island: Kamakou, Puu Kolekole Cabin: 2 ♀, 21.v.2007, M. J. Medeiros. Mtns., 914 m: 1 ♀, 13.vi.1893, Perkins (BMNH). Oahu Island: 610 m: 1 ♂, .iv.1893, slide 1698 wings BMNH, Perkins (BMNH). 610 m: 1 ♀, .iv.1893, slide 1595 BMNH, Perkins (BMNH). Koolau Mtns, Konahuinui Trail: 1 ♀, 1.v.2006, W. P. Haines. Manana Stream Trail, 305 m: 2 ♀, 18.v.2007, M. J. Medeiros. N.W. Koolau Range: 1 ♂, .v.1901 (BMNH). S.E. Koolau Range: 1 ♀, .vii.1900 (BMNH). Waianae Mtns, 610 m: 1 ♂, 1 ♀, .iv.1892, Perkins (BMNH). Waianae Mtns., Palikea Trail, > 914 m: 4 ♂, 16.v.2006, slide 06B00, slide and DNA 06B01, W. P. Haines (BPBM).

Host: Tree roots, probably of many tree species. Larvae occasionally are attracted to rotting mushroom baits used to collect native *Drosophila* (F. G. Howarth, pers. observ.).

Flight period: Adults and larvae are active throughout the year.

Distribution: This species normally occurs in epigeal habitats on at least Kauai, Oahu, Molokai, Lanai, Maui, and Hawaii Islands. It also occasionally occurs in caves on at least Maui and Hawaii Islands.

***SCHRANKIA HOWARTHI* DAVIS & MEDEIROS
SP. NOV.**

Similar to *Schrankia altivolans* in several morphological features, *S. howarthi* is a polymorphic, but predominantly smaller, more cavernicolous species that includes at least two relatively distinct forms: a generally smaller, indistinctly patterned, predominantly grey, deep cave (dark zone) adapted morph (Fig. 2D) and a slightly larger, more distinctly marked, cave entrance (twilight) to epigeal form (Fig. 2C). The forewings of the deep cave morph usually measure ~4–7 mm in length and possess a mostly greyish ground colour with a variably faint pattern of slightly darker, transverse lines. The forewings of the twilight morph are typically larger

(5.5–8.0 mm) and possess a variable pattern of more distinct whitish to brownish lines.

Description

Adult (Fig. 3E–J): *Head:* Vestiture mostly smooth, with low ridge sometimes evident projecting forward from vertex and from upper frons; scales moderately broad, possessing minutely dentate apices; generally pale brownish grey, occasionally paler brown laterally under antennal sockets. Antenna ~0.6× length of forewing; dense, piliform, pale grey cilia ventrally; cilia of male ~2× diameter of flagellomere in length, that of female ~1/2 the length of male cilia; a single row of moderately broad, pale grey scales dorsally over each flagellomere. Labial palpus variably pale to medium grey; second segment strongly compressed, usually with both dorsal and ventral margins slightly expanded and rough; apical segment smooth, slender, with nearly white apex.

Thorax: Generally medium to pale grey. *Forewing:* ground colour medium to pale grey with transverse lines varying from well marked to obscure; median band broad, irregular in outline, varying in colour from distinctly dark brown to grey and similar to ground colour; reniform usually included within medial band and indistinct; irregular antemedial and postmedial lines bordering medial band variably distinct, white to very pale grey; whitish subterminal line slender, sinuate, and usually interrupted in darker morphs to partitioned into a faint series of pale greyish white spots in most deep cave morphs; a series of often obscure dark brown adterminal spots positioned near ends of veins; fringe brown to grey. *Hindwing:* uniformly pale grey; base of fringe usually paler, more whitish.

Abdomen: Uniformly pale brownish grey.

Male genitalia (Fig. 5C–F): Uncus a single stout, elongate process, usually folded in repose ventrally between valvae, ~equal in length to moderately slender, V-shaped (inverted) tegumen. Vinculum well developed, broadly V- to U-shaped, ~1/2 the length of genital capsule. Juxta a small flat plate with paired slender, elongate, divergent processes anteriorly. Valva generally slender, gradually tapering to a slender, subacute apex bearing a prominent row of long, stout costal setae from subapical region; base of costa with a slender, elongate process ~0.6–0.7× length of uncus; ampulla a shorter, moderately stout truncate lobe 0.33–0.4× length of costal lobe, bearing usually six to eight elongate apical setae ~ the length of ampulla; sacculus terminating in a short, acute, slightly recurved lobe. Aedeagus slender, gradually enlarging to a slightly swollen base; ejaculatory duct

entering immediately above swollen base; cornuti consisting of numerous minute spines less than diameter of aedeagus in length concentrated in a dense, elongate mass along ventral distal third, with a few loose cornuti occasionally scattered more basally through vesica.

Female genitalia (Fig. 6B): Eighth segment relatively well developed forming a moderately broad ring; caudal margin with a shallow midventral cleft; anterior apophysis reduced, $\sim 1/3$ length of posterior apophysis. Ostium located at termination of a sclerotized, external tube of variable length projecting caudally from anterior margin of eighth sternum; length of ostium tube $\sim 0.6\text{--}0.8\times$ length of posterior apophysis. Ductus bursae without spicules, elongate, slender; walls over caudal $2/3\text{--}3/4$ densely wrinkled, but of approximately equal diameter throughout; length of ductus varying from $3.2\text{--}5.0\times$ the length of eighth segment. Ductus seminalis from juncture of ductus bursae and corpus bursae; Corpus bursae ovate, $\sim 0.4\times$ length of posterior apophysis; a small external swelling present near juncture of ductus bursae; internal wall densely covered with rows of \sim eight to 12 minute spicules (Fig. 6B); signum a single, small, irregular plate studded internally with numerous short, stout, acute spines.

Larva (Figs 2A, 7A–H, 8A–F, 9A–F): Maximum length of larva examined 12.5 mm; maximum diameter 1.2 mm. Body pale cream to white (in alcohol); pinacula undeveloped on abdomen; anal shield pale brown. *Head*: Maximum width 0.7 mm. Colour pale yellowish brown. Chaetotaxy as illustrated (Fig. 7A–H); caudal $3/4$ of cranium densely covered with minute microtrichia (Fig. 8B, C). Antenna arising from relatively deep pocket from anterolateral margin of cranium. Sensillae of antenna and maxilla as shown (Figs 8D–F, 9A). Stemmata (Figs 7D, 8C) usually with 2 to 4 distinct, 1 and 5 reduced, flat, 6 indistinct, possibly fused with 5. Labrum (Fig. 7F, G) with six pairs of dorsal setae, with M1, M3, La3 greatly reduced, M2, La2 the longest, and La1 of intermediate length; three pairs of stout epiphryngeal setae along anterior–ventral margin. Mandible (Fig. 7H) with four prominent, acute cusps with mesal cusp slightly reduced; lateral margins of cusps with minute, irregular serrations. *Thorax*: Pronotum and all pinacula nonpigmented (in alcohol), indistinct. D1 arising near middle of pronotum immediately below XD1; D2 arising lower and more caudad; SD1 and SD2 arising on small oblong pinnaculum narrowly separated from lower caudal angle of pronotum. Large prothoracic (cervical) gland present at midventer (Fig. 8A). Pretarsal claw elongate and slender; Coxae contiguous on all segments; T2 and T3 with

relatively large tactile vesicle often evident on mesal surface of coxae (Fig. 9C, D).

Abdomen: Cuticle densely papillate, each papilla bearing ~ 9 minute, relatively stout microtrichia (Fig. 10C). D1 and D2 arising at nearly the same level on A1–4, A7–8 and with D1 higher on A5–6, with D1 below D2 on A9. Subventral setae bisetose on A1–4, A7–8; trisetose on A5–6. Anal shield with D1 arising caudally near D2. Prolegs present only on A5–6, 10; crochets homoideus, uniserial, containing $\sim 13\text{--}16$ hooks.

Cocoon (Fig. 2D): Approximately spindle-shaped, composed of numerous small, mostly elongate pieces of brownish tree roots orientated predominantly lengthwise; maximum length of main body ~ 10 mm, often with some plant fragments extending caudally an additional 5–7 mm; maximum width $\sim 3\text{--}4$ mm. Cocoon attached by silk at anterior end to usually vertical tree roots penetrating from cave roof.

Holotype: USA: HAWAII: Hawaii Island: Keauhou, Keamoku Cave, dark zone, 1725 m: ♂, 7.ii.1974, F. D. Stone & H. E. Smith (BPBM type # 16841). This specimen was selected from a large, very uniform series, many individuals of which were dissected.

Paratypes: USA: HAWAII: Maui Island: Kanaio Upper Cave, approx. 545 m east, dark zone: 7 ♂, 21.ix.1982, slide USNM 32928, F. D. Stone. Puu Mahoe, Ulupalakua Lava Tube no 2, dark zone, 670 m: 4 ♂, 22.ii.1988, 1 ♂, 26.ii.1988, 5 ♂, 27.viii.1977, 10 ♂, 28.viii.1977, 1 ♂, 27–28.viii.1977, em. 11.xi.1977, 1 ♀, 27–28.viii.1977, em. 13.ix.1977, 1 ♂, 27–28.viii.1977, em. 29.x.1977, slide USNM 32929, 1 ♀, 27–28.viii.1977, em. 31.x.1977, 1 ♂, 27–28.viii.1977, em. 4.xi.1977, 1 ♀, 27–28.viii.1977, em. 6.xi.1977, slide USNM 32930, 1 ♂, 27–28.viii.1977, em. 6.xi.1977, F. G. Howarth, 1 ♂, 28.viii.1977, slide USNM 33090, F. G. Howarth & G. K. Uchida. Hawaii Island: Blair Cave, dark zone, 1069 m: 1 ♂, 30.iv.1972, slide USNM 16960, F. G. Howarth. Blair Cave, near entrance, 1069 m: 1 ♂, 30.iv.1972, F. G. Howarth. Hawaii Volcanoes National Park: Ainahou Lava Tube, 900 m: 9 ♂, 4.i.1982, slide USNM 33084, F. D. Stone & F. G. Howarth; Ainahou Lava Tube, twilight deep, 855 m: 1 ♂, 24.x.1982, em. 6–7.xi.1982, F. G. Howarth. Hawaii Volcanoes National Park: Apua Cave, dark zone, 8–900 m: 12 ♂, 10.ii.1974, slide USNM 33083, F. G. Howarth; Mauna Loa Strip trail, Koa Tree Mold Cave, twilight zone, 1220 m: 3 ♂, 8.iii.1973, slide USNM 16955, F. G. Howarth; Petroglyph Cave, 975 m, twilight: 1 ♂, 21.ii.1980, F. G. Howarth; Thurston Lava Tube, [~ 1190 m]: 1 ♂, 15.vii.1976; Thurston Lava Tube, dark zone, 1200 m:

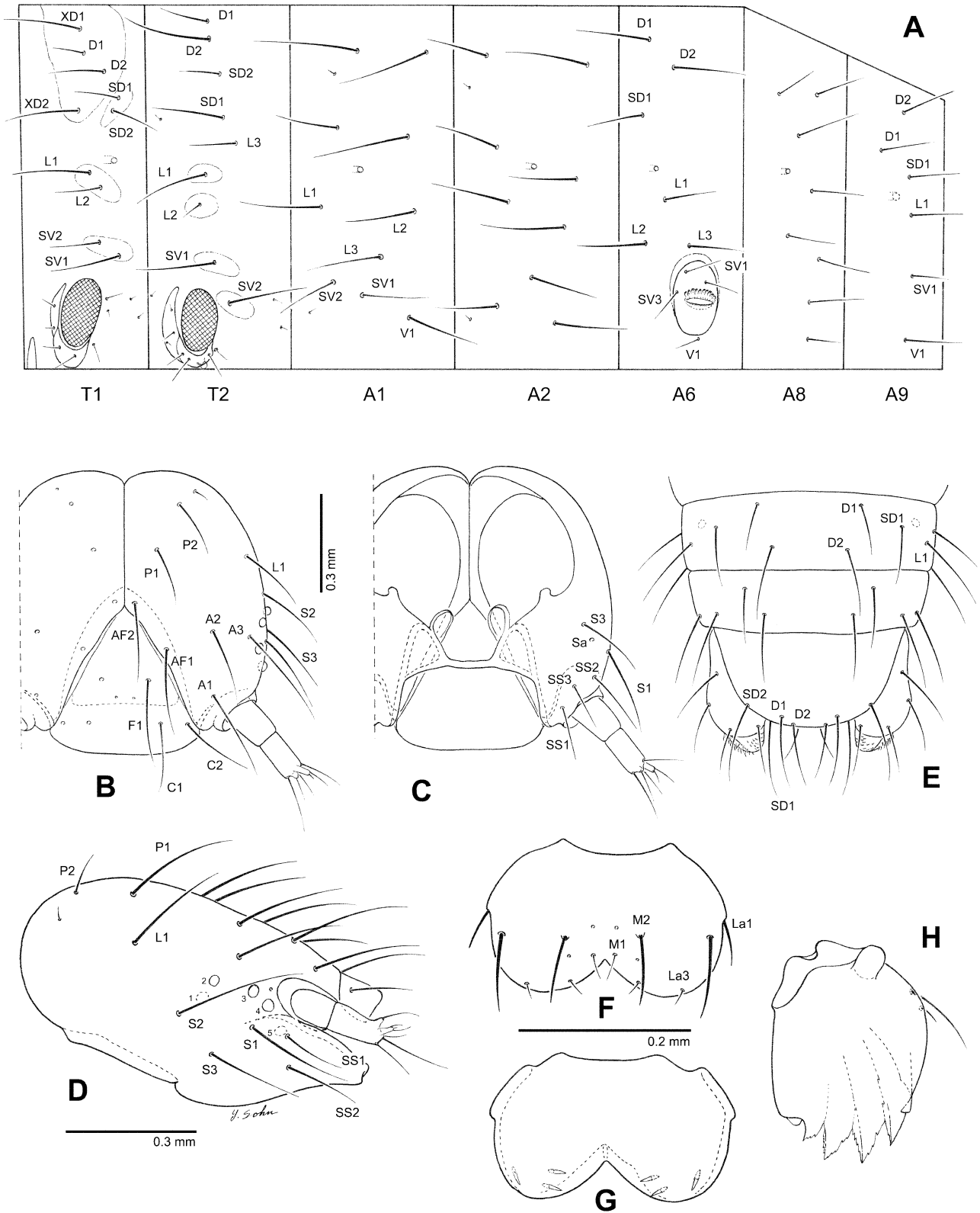

Figure 7. *Schrankia howarthi*, Keamoku Cave, Hawaii Island, dark zone, slide 35787, chaetotaxy of late instar larva. A, lateral diagram of prothorax (T1), mesothorax (T2), and abdominal segments 1, 2, 6, 8, and 9. B, dorsal view of head. C, ventral view of head. D, lateral view of head. E, dorsal view of abdominal segments 8–10. F, dorsal view of labrum. G, ventral view of labrum. H, right mandible.

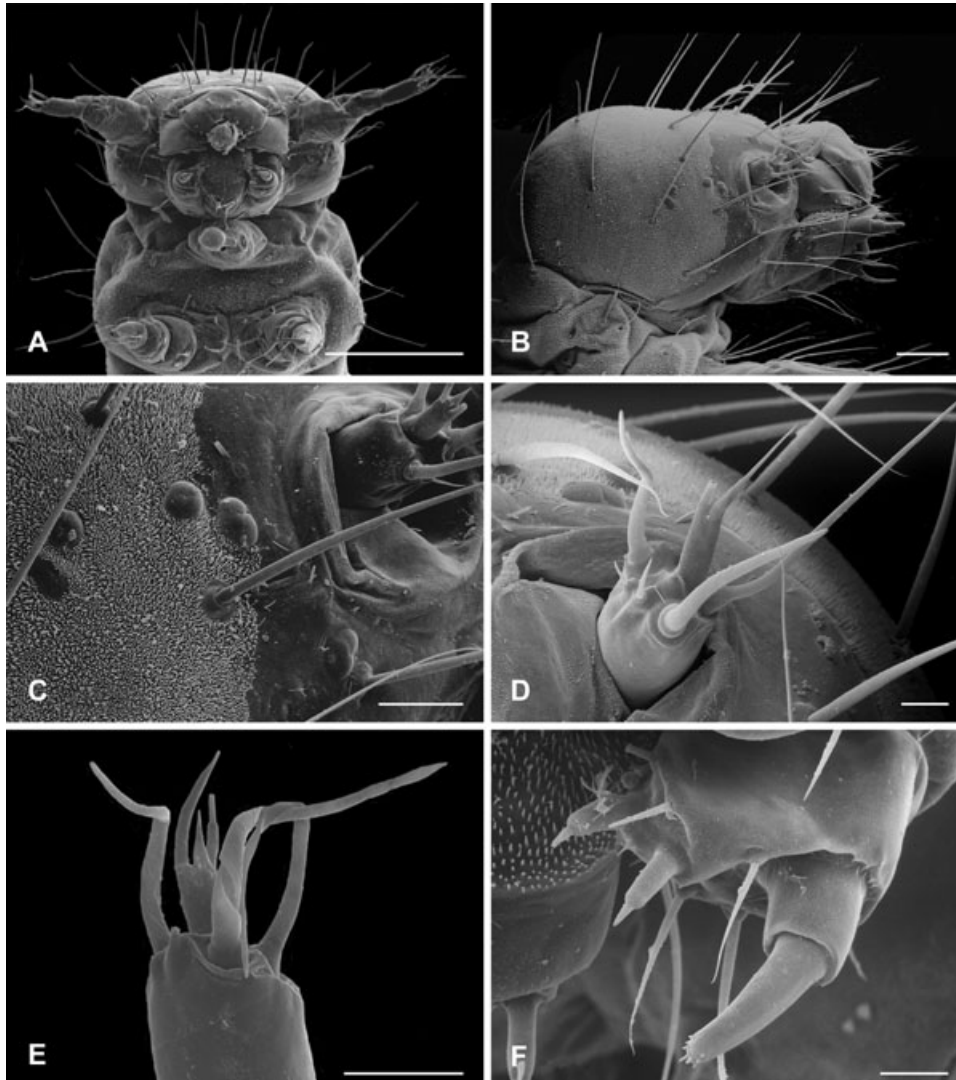

Figure 8. *Schrankia howarthi*, Keamoku Cave, Hawaii Island, dark zone, slide 28776, late instar larva. A, ventral view of head with antennae fully extended and prothorax (0.43 mm). B, lateral view of head (100 μ m). C, detail of stemmatal area in B (50 μ m). D, anterior view of retracted antenna (20 μ m). E, lateral view of antenna (43 μ m). F, anterior view of maxilla (20 μ m). Scale lengths given in parentheses.

1 larva, 3.iii.1973, died 15.iii.1973, on tree roots, F. G. Howarth. Kaumana Cave, Mauka section, dark zone, 300 m: 1 larva, 2.x.1971, F. G. Howarth. Kaumana Cave, dark zone, 290 m: 2 σ , 30.x.1972, F. G. Howarth. Keauhou Ranch, 7 km north of Kilauea, Keamoku Cave, dark zone, 1870 m: 2 σ , 8 larvae, 11.xii.1976, larval slides USNM 20250, 28776, 35787, D. & M. Davis & F. Howarth. Kealakekua Ranch, Shelter Cave, dark & twilight zone, 1310 m: 25 σ , 1 larva, 10.xii.1972, slides USNM 16757, 20251 (larva), F. G. Howarth, W. C. Gagne & J. Jacobi; 1 σ , 10.xii.1972, em. 21.xii.1972, 1 σ , 10.xii.1972, em. 25.xii.1972, slide USNM 33570, 1 σ , 21.xii.1972, F. G. Howarth. Kealakekua Ranch, Shelter Cave, dark

zone, 1310 m: 1 σ , 10.xii.1972, em. 18.xii.1972, slide USNM 17505, F. G. Howarth, W. C. Gagne & J. Jacobi. Kealakekua Ranch, Stone Wall Cave, twilight zone, 1225 m: 5 σ , 1 σ , 11.xii.1972, F. G. Howarth, W. C. Gagne & J. Jacobi. Kealakekua Ranch, upper Papaloa Cave, dark? Zone, 1600 m: 4 σ , 1 σ , 10.xii.1972, 1 σ , 10.xii.1977, em. 17.xii.1972, slide USNM 16953, F. G. Howarth, W. C. Gagne & J. Jacobi. Keauhou, Keamoku Cave, dark zone, 1725 m: 2 σ , 1 σ , 1 σ , 7.ii.1974, F. D. Stone & H. E. Smith; 3 σ , 5.vii.1976; 1 σ , 5.vii.1976, em. 9.vii.1976, F. G. Howarth; 3 σ , 8.vii.1976, F. G. Howarth; 5 σ , 10.vii.1976, F. G. Howarth & K. Sattler; 1 σ , 13.vii.1973, em. 30.vii.1973, F. G. Howarth. Keauhou

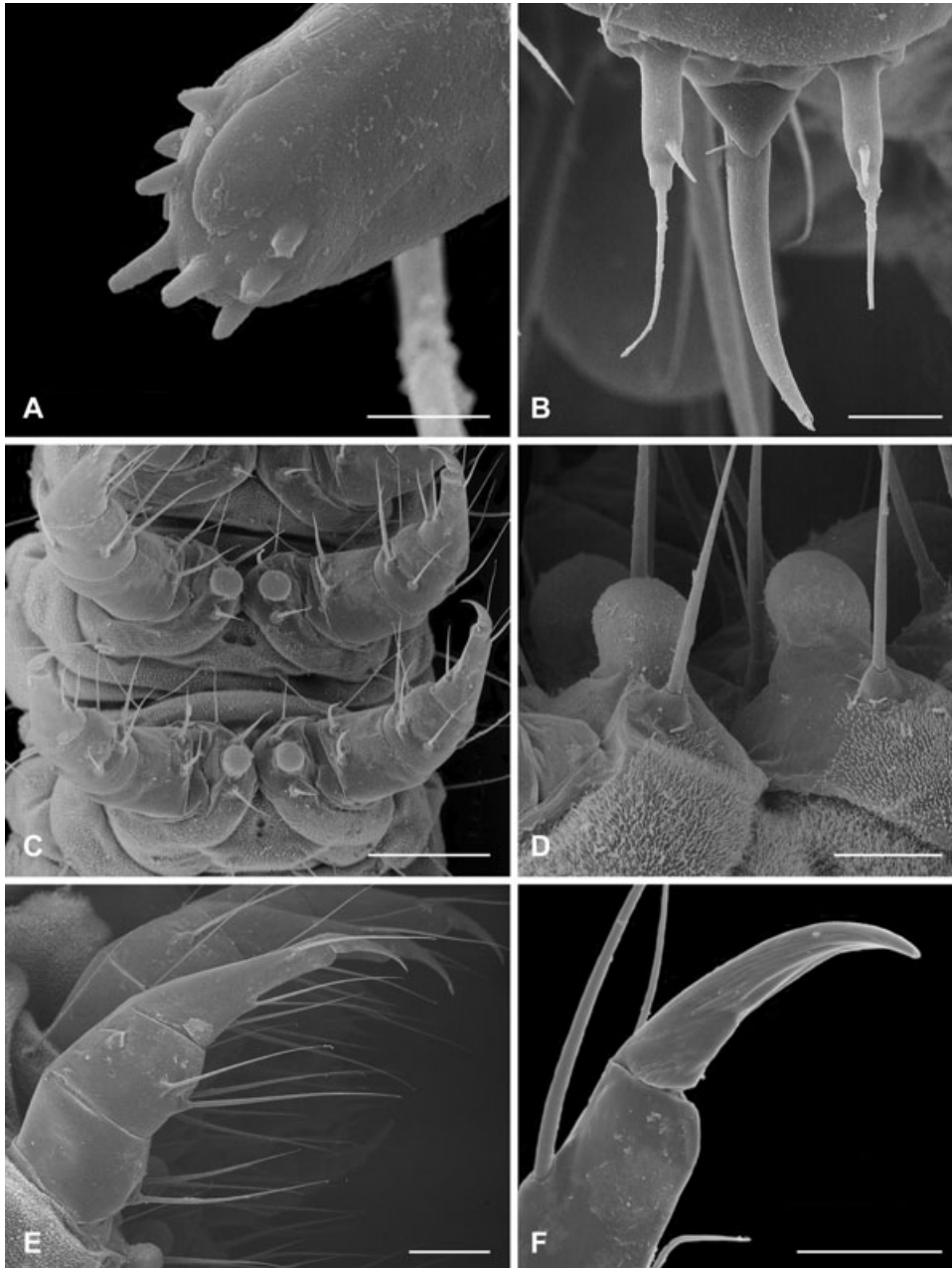

Figure 9. *Schrankia howarthi*, slide 28776, late instar larva. A, apex of maxillary palpus (5 μ m). B, dorsal view of labial palpi and spinneret (20 μ m). C, ventral view of pro- and mesothorax (200 μ m). D, caudal detail of tactile vesicles in C (50 μ m). E, caudal view of metathoracic leg (100 μ m). F, lateral view of mesothoracic pretarsal claw (38 μ m). Scale lengths given in parentheses.

Ranch, Aaa Keamoku Cave, dark zone, 1740 m: 3 σ , 13.vii.1973, F. G. Howarth. Keauhou Ranch, Keamoku Cave, dark zone, 1725 m: 1 σ , 11.xii.1976, em. 4.i.1977, F. G. Howarth. Keauhou Ranch, Keamoku Cave, 1800 m: 1 σ , 11.xii.1976, em. 19.i.1977, 1 σ , 11.xii.1976, em. 28.i.1977, slides USNM 33082, 33087, F. G. Howarth. Keauhou Ranch, Keawewai Cave # 4, twilight zone, 1800 m: 1 σ ,

10.xii.1976, em. 12.xii.1976, DRD lot 4325, D. R. Davis. Keauhou Ranch, Keauhou Ranch, Sandy's Cave, dark zone, 1725 m: 1 σ , 6.vii.1974, E. Smith. Kilauea, Aaa Keamoku, dark zone, 1725 m: 1 σ , 8.vii.1976, em. 12.vii.1976; 1 σ , 13.vii.1973, F. G. Howarth. Kilauea Forest Res. Cave No 2, twilight zone, 1650 m: 2 σ , 27.iv.1972, D. R. Davis. Kipuka near Saddle Rd, Powerline Rd Cave, 1881 lava flow,

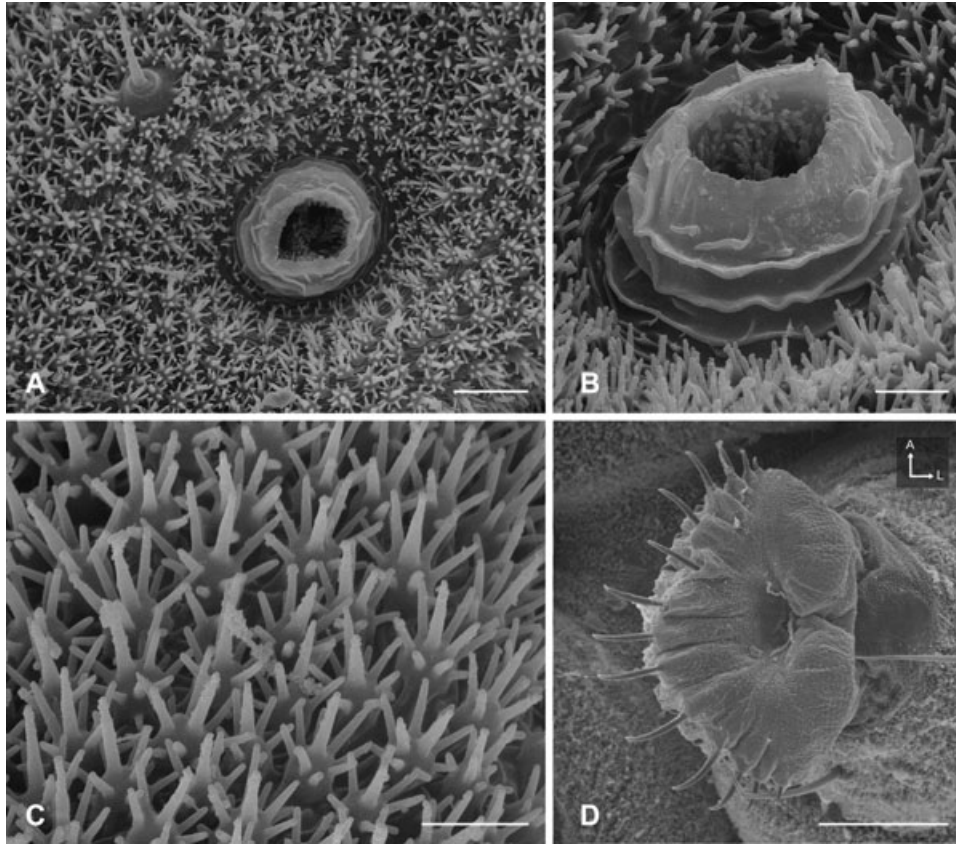

Figure 10. *Schrankia howarthi*, slide 28776, late instar larva. A, spiracular area of third abdominal segment (10 µm). B, third abdominal spiracle (5 µm). C, detail of third abdominal cuticle (5 µm). D, left proleg of abdominal segment 5 (100 µm); A, anterior, L, lateral. Scale lengths shown in parentheses.

dark zone upper passage, 1760 m: 1 ♂, 1 ♀, 10.iii.1973, F. G. Howarth. Kipuka on Saddle Rd, Powerline Rd Cave, dark zone lower passage, 1760 m: 2 ♀, 10.iii.1973, slide USNM 16952, F. G. Howarth. Kipuka on Saddle Rd, Powerline Rd Cave, dark zone upper passage, 1760 m: 1 ♂, 1 ♀, 10.iii.1973, slide USNM 17506, F. G. Howarth. Kipuka, Puauulu, 1250 m: 1 ♂, 6.vi.1976, F. G. Howarth. Kipuka, Puauulu, Bird Park Cave # 1, entrance: 1 ♂, 6.vi.1976, F. G. Howarth. Kurtistown Cave, dark zone, 168 m: 1 ♀, 7.iii.1976, F. G. Howarth. Kurtistown Cave (or Kazumura), 168 m: 1 ♂, 1.iii.1976, F. G. Howarth. Kurtistown, Kazumura Cave, 168 m: 1 ♂, 7.iii.1976, F. G. Howarth. Kurtistown, Orchidland Caves, twilight zone, 168 m: 2 ♂, 18.ii.1974, F. G. Howarth. Lower Pahoia Cave, 180–190 m: 3 ♂, 1 ♀, 7.ii.1987, W. C. Gagné. Mountain View: Kazumura Lava tube, ~8 km SE Mountain View: dark zone, 170 m south-east of north-west end upper level room, 480 m: 5 ♂, 8.xii.1976, D. & M. Davis. Kazumura Lava tube, 400 m: 1 ♂, .viii.1979, F. G. Howarth. Kazumura Lava tube, dark zone: 2 ♂, 8.vi.1980, F. G. Howarth. Kazumura Lava tube, dark zone, 300 m: 4 ♂,

4.ix.1977, F. G. Howarth. Kazumura Lava tube, dark zone, 400 m: 4 ♂, 25.ii.1980; 10 ♂, 30.vii.1976, slide USNM 33091, K. Sattler; 1 ♂, 14.viii.1977; 1 ♂, 28.x.1979; 2 ♂, 4.ix.1977, F. G. Howarth; 2 ♂, 4.ix.1979, F. G. Howarth & S. L. Montgomery. Kazumura Lava tube, twilight zone, 400 m: 1 ♂, 1 ♀ 11.viii.1979, DRD 4326, F. G. Howarth. Mountain View: Bellows Cave, Kazumura, dark zone, 400 m: 3 ♂, 12.ii.1974, F. G. Howarth; Bellows Cave, Lava tube, dark zone, 300 m: 1 ♂, 4.ix.1979, F. G. Howarth & S. L. Montgomery. Kazumura Cave, 400 m: 1 ♂, 16.ii.1974, F. G. Howarth. Kazumura Cave, 1220 m from entrance, 400 m: 1 ♂, 13.vii.1972; 3 ♂, 14.vii.1972, slide USNM 16954; 3 ♂, 15.vii.1972, F. G. Howarth. Kazumura Cave, dark zone, 400 m: 3 ♂, 8.vii.1973, slide USNM 33081, F. G. Howarth; 1 ♂, 30.vii.1976, K. Sattler; 4 ♂, 1 ♀, 1.xi.1972, slides USNM 17518, 17517; 1 ♂, 8.xii.1972, F. G. Howarth. Mauna Loa: Bird Park Cave No. 1, 1220 m: 1 ♂, 9.xii.1976, D. & M. Davis; Bird Park Cave No. 2, 1250 m: 1 ♂, 9.xii.1976, D. & M. Davis. N. Kona, Huehue Ranch Cave, transition and dark zone, 600–640 m: 10 ♂, 29.viii.1979, slide USNM 33085, F. G.

Howarth. Pahoia, Pahoia Cave, dark zone, 150 m: 1 ♂, 1 ♀, 7.vii.1973, slides USNM 16958, 17504, F. G. Howarth. Powerline Rd, Pole 25, Emesine Cave, upper section, 1760 m: 1 ♂, 14.ii.1974, slide USNM 32933, F. D. Stone. Emesine Cave, Saddle Road, 1600 m, deep twilight: 6 ♂, 18.viii.1979, F. G. Howarth; dark zone, lower section, 1 ♂, 18.viii.1977, F. G. Howarth, slide USNM 32931. Puna, Glenwood, Kokokahi Cave, dark zone, 756 m: 1 ♂, 31.viii.1977, F. G. Howarth. Puna, McKensie Park, McKensie Lava tube, dark, 15 m: 3 ♂, 1 ♀, 7.i.1985, F. G. Howarth & F. D. Stone. Puna, Pahoia Cave, dark zone, 150 m: 6 ♂, 20.viii.1977, slide USNM 33086; 3 ♂, 1.ix.1977, F. G. Howarth. Saddle Rd, Mauna Loa, Powerline Rd Cave, dark zone upper passage, 1760 m: 1 ♂, 18.iii.1973, F. G. Howarth. Paratypes deposited in BMNH, BPBM, and USNM.

Additional material examined: USA: HAWAII: Hawaii Island: Hawaii Volcanoes National Park: Ainahou Cave, E < 22: 3 ♂, 13.vi.2005, slides and DNA LA06 & LA07, slide LA05, F. G. Howarth & F. Stone (BPBM). Hawaii Volcanoes National Park, Ainahou Cave: 1 ♀, 30.v.2006, slide and DNA 06A91, M. J. Medeiros; Escape Road, 1128 m: 1 ♂, 26.v.2006, slide and DNA 06A51, M. J. Medeiros. Kazumura Cave: 1 ♂, 20.xii.2003, slide and DNA 03A15; 2 ♂, 28.v.2006, slide and DNA 06A73, and slide 06A75, M. J. Medeiros. Emesine Cave: 1 ♂, 20.vii.2004, slide and DNA 04A66; 2 ♂, 26.v.2005, slides and DNA 05A34 and 05A36; 1 ♀, 29.v.2006, slide and DNA 06A83, M. J. Medeiros. Kaumana Cave: 2 ♂, 17.vii.2004, slides and DNA 04A38 & 04A39; 2 ♂, 2 ♀, 25 May 2005, slides and DNA 05A10, 05A11, 05A14 & 05A15; 2 ♂, 1 ♀, 20.x.2006, slide and DNA 06B80, DNA 06B76 & 06B77, M. J. Medeiros. Puu Waawaa Cave: 2 ♂, 2 ♀, 30.v.2005, slide 05A60, slides and DNA 05A61, 05A62, 05A63 & 05A64, M. J. Medeiros. Kula Kai Cave, 2 ♂, 26.v.2006, DNA 06A41 & 06A43, M. J. Medeiros. Kipuka Puauulu: 1 ♂, 27.v.2006, slide and DNA 06A68, M. J. Medeiros. Stainback Hwy., at junction with Tree Planting Rd: 2 ♂, 25.v.2005, slide and DNA 05A24, DNA 05A32. Maui Island: Thaumatoeryllus Cave: 2 ♂, 19.x.2006, slides and DNA 06B63, DNA 06B66, M. J. Medeiros. These specimens are deposited in BPBM.

Host: Most feeding records are from roots of presumed *Metrosideros polymorpha*, the dominant native rain-forest tree and early pioneer on new lava flows, but *S. howarthi* is not host-specific. Cocoons and feeding damage have been observed on most types of available roots in caves, including *Grevillea robusta*, *Eucalyptus* spp., *Cocculus orbiculatus*, pasture grasses, and many unidentified roots. Larvae are also attracted to a variety of rotting baits and appear to

act as scavengers in caves. In the laboratory, they have been reared on sprouted corn roots.

Parasitoid: No parasitism has been observed. However, pupae and adults are frequently attacked by an unidentified fungus, which occasionally causes epizootics in cave populations.

Flight period: Adults and larvae are active throughout the year. Adult records are available for every month.

Distribution: This species normally occurs within the twilight to dark zone areas of lava tubes on the islands of Maui and Hawaii; however, it is sometimes found flying on the surface of both islands. The paler morph may be restricted to the dark zone of lava tubes.

Etymology: The species is named in honour of Dr Frank Howarth (Francis G. Howarth, author of this current paper), an entomologist at the Bernice P. Bishop Museum who has pioneered Hawaiian biospeleology. Dr Howarth first discovered this species and collected most of the approximately 250 specimens examined.

FLIGHTLESSNESS – DROP TEST

A total of 54 *S. howarthi* was dropped in caves on Maui and Hawaii Islands (Table 2). For dark-zone morph individuals, 31% of males ($N = 26$) and 50% of females ($N = 2$) were assessed to be 'flightless'. For twilight-zone morph individuals, 5% of males ($N = 19$) and 43% of females ($N = 7$) were flightless. Each sex and morph of *S. howarthi* had at least one flightless individual and at least one individual that was capable of ascending flight. All ten control epigeal individuals we dropped were capable of ascending flight, which is not surprising given that we caught

Table 2. Drop test results

	Capable of ascending flight	No ascending flight
Dark-zone morph <i>howarthi</i> males	18	8
Dark-zone morph <i>howarthi</i> females	1	1
Twilight zone morph <i>howarthi</i> males	18	1
Twilight zone morph <i>howarthi</i> females	4	3

them either while flying, or while perched after flying and landing on a blacklight sheet.

PHYLOGENETIC ANALYSIS

Species determinations for moths used in phylogenetic analysis were based upon the characters discussed in the individual species sections. We sequenced a total of 529 base pairs (bp) for COI, 509 from COII, and 451 for *wingless*. The concatenated COI, COII, and *wingless* fragments resulted in a character matrix 1489 bp in length containing 262 variable characters, 107 of which were parsimony informative. The number of parsimony informative sites was low for *wingless* (17 sites or only 4%). There were more informative sites for mtDNA (55 informative sites for COI, or 10% of sites; 35 for COII, 7%). When analysed on its own, *wingless* did not have any supported nodes, and the inclusion of *wingless* did not significantly alter the tree topology for any of the analytical methods below.

Maximum likelihood

The most likely tree is shown in Figure 11. Bootstrap confidence is generally low, possibly because of homoplasy (as in Magnacca & Danforth 2006, 2007), short branch lengths and/or a lack of time since divergence between the two species of Hawaiian *Schrankia*, and even between the ingroup and outgroup taxa. The Hawaiian *Schrankia* appear to be monophyletic. *Schrankia altivolans* is shown to be a monophyletic group nested within the paraphyletic *S. howarthi* grade, with two exceptions: One *S. altivolans* individual captured on the surface of Hawaii Island is placed in the *S. howarthi* grade, as is one *S. altivolans* individual found in Kaumana Cave on Hawaii Island. One other *S. altivolans* found in Kaumana Cave is grouped with the other *S. altivolans*. Individuals which had wing patterns similar to each of the five original Hawaiian *Schrankia* species were scattered throughout the *S. altivolans* clade. All Maui *S. howarthi* individuals formed a subclade within the *S. howarthi* grade.

Bayesian inference

The topology of the recovered tree is similar to that of the maximum likelihood (ML) tree and the posterior probabilities for each of the supported nodes are indicated on Figure 11. No nodes with a posterior probability > 50% were recovered that conflicted with any nodes, regardless of support level, of the ML tree. *Schrankia altivolans* still forms a monophyletic group nested within a paraphyletic *S. howarthi* grade, with the exception of the same two individuals. A large

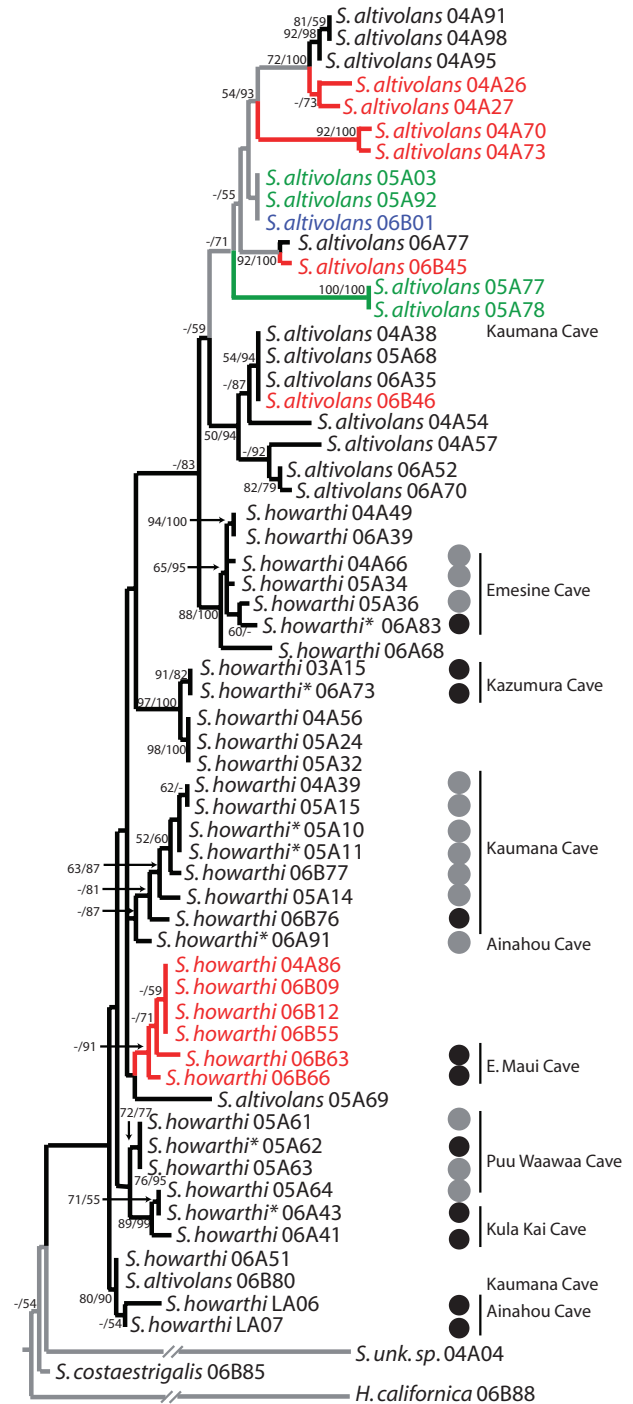

Figure 11. Maximum likelihood phylogram. Bootstrap values greater than 50% are illustrated on tree as first value; Bayesian posterior probabilities are the second value. Values < 50 are not labelled. Colours represent islands (black is Hawaii Island; red is Maui, blue is Oahu; green is Kauai). Asterisks denote flightless individuals. Black circles represent dark-zone morph *Schrankia howarthi*; grey circles represent twilight-zone individuals. Locality information for individual moths may be found in the Appendix.

polytomy at the base of the ingroup limits resolution within the *S. howarthi* grade.

Maximum parsimony

Both PAUP* and PAUPrat found most parsimonious trees with a length of 434. A strict consensus of the first 10 000 most parsimonious trees found in PAUP* was largely in agreement with the Bayesian and ML trees, with one notable difference: *S. howarthi* moths from Emesine Cave on Hawaii Island combined with the *S. altivolans* clade to form a monophyletic group. However, this topology was not supported by bootstrapping: None of the nodes that had bootstrap values > 50% conflicted with any of the nodes generated through ML or Bayesian analysis.

DISCUSSION

The short branch lengths within the *S. howarthi* paraphyletic grade suggest that moths from all lava tubes sampled, including on both Maui and Hawaii islands, belong to a single species. However, several *S. howarthi* individuals were collected while flying on the surface. Both sexes of these epigeal moths have similar wing patterns to twilight zone morph moths found in caves on both Maui and Hawaii Islands, and the male genitalia are indistinguishable from those of moths found in both the twilight zone and dark zones of all caves sampled. Genetic distance among all *S. howarthi* is very low: total genetic divergence for all loci sampled ranged from 1.63% amongst moths from caves on different islands and 0.92% amongst individuals collected on the surface and those found in a cave on Hawaii Island. *Schrankia howarthi* is paraphyletic, but species may go through periods of paraphyly early in their existence, after a monophyletic assemblage splits from a group. This original paraphyly may be the result of recent local divergence of the monophyletic group or because of incomplete lineage sorting. Only after enough time has passed will both species in question be reciprocally monophyletic (Harrison, 1998).

Our phylogenetic analysis indicates that *S. altivolans* is nested within *S. howarthi*. Two *S. altivolans* individuals were recovered in the *S. howarthi* grade but this placement is not surprising: in recently diverged or rapidly diverging groups, hybridization, or more likely lineage sorting, can lead to 'incorrect' placement of individuals in a species tree that is heavily influenced by mtDNA (Shaw, 2002).

Schrankia howarthi has two morphs: a twilight zone morph which can be found on the surface as well as all ecological zones of caves, and a dark zone morph, which is most frequently found in the dark zone of caves but occasionally near a cave entrance. Our decision to consider cave moths (and a few

similar surface moths) from Maui and Hawaii Islands to be all one species (*S. howarthi*) is based on low genetic distance even within rapidly evolving mtDNA, and morphological similarity with no discrete or consistent character variation amongst populations. Over time, however, the reduction in gene flow amongst some caves and islands, as evidenced by the presence of subclades within *S. howarthi*, may lead to further divergence. Within the *S. howarthi* paraphyletic grade, there is evidence of reduced gene flow. Moths from individual caves sometimes form clades or grades, and all Maui *S. howarthi* (cave and epigeal) sampled form a supported clade. Therefore, gene flow amongst *S. howarthi* from different islands is likely to be low, and based on the recovery of supported cave-clades within Hawaii Island *S. howarthi*, gene flow is likely to be low amongst caves on the same island.

Twilight-zone morph individuals within *S. howarthi* have been collected on the surface of both Maui and Hawaii Islands, but not from any other islands. This species appears to have originated on Hawaii Island, and then colonized the older island of Maui. This biogeographical pattern of younger → older does not conform to the 'progression rule' hypothesis (see Funk & Wagner, 1995; Roderick & Gillespie, 1998) that much of the Hawaiian biota colonized younger islands after older islands. *Schrankia*, like recently investigated Hawaiian *Hylaeus* bees (Magnacca & Danforth, 2007) suggest that the order of island colonizations within a group of organisms can violate the progression rule, particularly if colonization took place recently, after multiple Hawaiian islands emerged (Funk & Wagner, 1995; Ballard & Sytsma, 2000; Arnedo & Gillespie, 2006).

Although *S. altivolans* shows stronger morphological affinity in terms of male genitalia to *S. costaestrigalis* than does *S. howarthi*, morphological distance may not always reflect phylogenetic relationships (we also cannot rule out multiple invasions of the Hawaiian Islands by *S. costaestrigalis*). The most ancestral *S. howarthi* occur on Hawaii Island, the youngest island in the Hawaiian archipelago, indicating that the *Schrankia* group colonized the Hawaiian Islands within the last 1.0–0.5 Myr (Price & Clague, 2002). This finding echoes that of Magnacca & Danforth (2007), who found that *Hylaeus* bees in Hawaii have rapidly diversified after initially colonizing Hawaii Island, and that of Holland & Cowie (2007) for populations of a species of Hawaiian snail. (However, it bears remembering that lineages that appear to have originated on Hawaii Island may actually have originated on an older island whose populations are now extinct or were not sampled.) As with the *S. howarthi* grade, there is no evidence of the progression rule for populations on different islands within the *S. altivolans* clade, which is not surprising, given that

Schrankia colonized Hawaii Island before any of the other islands.

CAVE INVASION IN HAWAIIAN *SCHRANKIA*

Within *S. howarthi*, there is no clear pattern of cave colonization. Instead of a pattern of surface-living (twilight zone morph) → twilight zone morph → dark zone morph individuals within the *S. howarthi* grade, moths of all three types are scattered throughout the Hawaii Island and Maui subgroups. One possible explanation for this pattern is that some twilight zone morph *S. howarthi* individuals travel between the epigeal and hypogean environments, and therefore, cave populations within any one island are not reproductively isolated from surface populations. Although *S. howarthi* taken from caves quickly perish on the surface on hot, sunny days, our sampling efforts indicate that they can survive on the surface on cool, misty nights that provide conditions like those in the hypogean environment.

A predisposition for hypogean living has also been documented in other *Schrankia*, including Japanese populations of *S. costaestrigalis*, which readily colonize railroad tubes and other underground spaces at all life stages (Yoshimatsu, 1995) and an unidentified species of *Schrankia* from lava tubes in Queensland, Australia (Howarth & Stone, 1990). *Schrankia* may not frequently leave caves after wandering in in search of food, given their low phototaxy. Likewise, ground-living and a preference for dark habitats has been considered a pre-adaptation – or an exaptation (Gould & Vrba, 1982) – for cave colonization among Canary Island dysderid spiders (Arnedo *et al.*, 2007). In both these spiders and Hawaiian *Schrankia*, phylogenetic analysis reveals multiple switches between cave and epigeal habitats. For *Schrankia*, as in these other groups, hypogean living appears to provide an almost unlimited food source in the form of tree roots, as well as a space that is free from at least two possible epigeal predators native to Hawaii: birds and bats. In general, the phylogenetic pattern seen in the *S. howarthi* grade is consistent with Arnedo *et al.*'s (2007) hypothesis of exaptation: Because the epigeal forms can readily colonize caves and vice versa, at least occasional gene flow will be likely to remain between surface and cave adapted individuals, impeding their ability to differentiate into exclusively cave adapted species. *Schrankia* throughout the world are evidently well suited to underground living.

The results of the drop test indicate that flightlessness is neither characteristic of all female *S. howarthi*, nor can all male cave *S. howarthi* fly. Flight ability may be the result of developmental differences or genetic variation within *S. howarthi*, and may

evolve more strongly in the future. Even for individuals without the ability to ascend, descent was still often controlled. Controlled descent may confer some selective benefit and be retained in populations even in cases where selection is not strong enough to maintain the ability to ascend during flight (Yanoviak *et al.*, 2005); however, directed aerial descent in complete darkness, and where there are no aerial predators – such as in Hawaiian caves – may not offer these advantages. Although Hawaiian *Schrankia* do not present the possibility of studying the parallel evolution of flightlessness, because flightlessness is not a consistent character in any given population, other questions about phenotypic plasticity and development are raised and should be the subject of future rearing experiments. Given the short branch lengths and divergence time of *S. howarthi*, flightlessness may be in the process of evolving, especially because fecundity may increase as energy expended to maintain unnecessary thoracic musculature decreases (Roff, 1990). Flightlessness in both sexes is rare in Lepidoptera and *S. howarthi* can be added to the alpine living *T. apatela* (Zimmerman, 1978; Sattler, 1991) as an example of a Hawaiian moth that – at least sometimes – exhibits flightlessness in both sexes.

Although most of the female *S. howarthi* specimens examined were reared from pupae, the individuals used in the drop test were caught perched high on roots in caves, which may have biased the sample towards moths that can fly. Also, *S. howarthi* is strongly prone to feigning death, sometimes spectacularly so. This is likely to be an adaptation to avoid predators in caves such as Lycosid spiders. Because this behaviour may have influenced the drop tests, we dropped each moth five times and discounted any drops when this behaviour was exhibited.

In terms of the original hypotheses of mechanisms of cave colonization, clearly the CRH can be ruled out because surface-living conspecifics of *S. howarthi* are extant. The hypothesis that the ASH in its strict sense has occurred in the past may also be rejected because there has not been speciation between cave dwelling and epigeal *S. howarthi*. The pursuit of food and/or predator-free spaces in caves is a shift in habitat use, but if gene flow continues between epigeal and hypogean individuals, disruptive selection will probably not be sufficiently strong to cause species divergence. Additionally, the occasional presence of *S. altivolans* in caves suggests that both species of Hawaiian *Schrankia* are well suited to underground life.

Dark-zone morph *S. howarthi* do not appear to be obligately troglomorphic species; rather, they are here shown to be phenotypic variants within *S. howarthi*. This is the first Hawaiian example of individuals of

the same species with a troglobitic phenotype found in caves on different islands of the Hawaiian chain. Possibly, the dark zone morph individuals from Maui and Hawaii islands display characteristics such as slight wing reduction, reduced eyes, and lack of pigmentation because of developmental changes that result from environmental factors common to the dark-zone of caves. The ability of most individuals to fly must facilitate dispersal and gene flow and allow for inter-island cave colonization. Intra-island colonization of new caves may be the result of above- or below-ground dispersal, or a combination of the two. In contrast, many (but not all) other groups that have colonized Hawaiian lava tubes, such as millipedes, spiders, isopods, and crickets, cannot fly.

ACKNOWLEDGEMENTS

We thank Jordana Anderson, Miguel Arnedo, Sam Aruch, Sara Backowski, Randy Bartlett, Kalena Blakemore, Jahkotta Burrell, Ring Cardé, Idelle Cooper, Mignon Davis, Robert Dudley, Ric Elhard, Melody Euaparadorn, Scott Fay, Betsy Gagné and the Hawaii DOFAW, Jon Giffin, Will Haines, Ryan Hill, Martin Honey, Kevin Jenkins, Raina Kaholoa'a, Adam Leaché, David Medeiros, Steve Montgomery, Pete Oboyski, Kevin Padian, Bonnie Ploger, Jerry Powell, Kathlyn Richardson, Summer Roper, Harry A. Schick, Michal Shuldman, Wayne Souza and the staff at Kokee State Park, Fred Stone, Kevin Tuck, and the staffs of Haleakala National Park and Hawaii Volcanoes National Park for help with collecting, logistics, and advice. Photographic assistance was provided by John Steiner and the late Victor Kranz, Smithsonian Photographic Services, Susan Braden, formerly of the Smithsonian Scanning Electron Microscope Laboratory, H. Hoch, Museum für Naturkunde, Berlin, (Fig. 2A); and William Mull, Volcano, Hawaii (Fig. 2B–D). We also thank Patricia Gentili-Poole, Department of Entomology, Smithsonian Institution, for her assistance with photographs and preparing the plates for publication. Line illustrations were by Young Sohn, Department of Entomology, Smithsonian Institution. This research was supported in part by: Society for Integrative and Comparative Biology, Sigma Xi, Smithsonian Institution Research Opportunity Fund, University of California, Berkeley, Dept of Integrative Biology, University of California Pacific Rim Research Project, Xerces Society, National Speleological Society, Cave Research Foundation, Margaret C. Walker Fund for teaching and research in systematic entomology. The work presented here represents a portion of M. J. Medeiros's PhD dissertation research at the University of California, Berkeley.

REFERENCES

- Arnedo MA, Gillespie RG. 2006.** Species diversification patterns in the Polynesian jumping spider genus *Havaika* Proszynski, 2001 (Araneae, Salticidae). *Molecular Phylogenetics and Evolution* **41**: 472–495.
- Arnedo MA, Oromí P, Múrria C, Macías-Hernández NE, Ribera C. 2007.** The dark side of an island radiation: systematics and evolution of troglobitic spiders of the genus *Dysdera* (Araneae, Dysderidae) in the Canary Islands. *Invertebrate Systematics* **21**: 623–660.
- Ballard HE, Sytsma KJ. 2000.** Evolution and biogeography of the woody Hawaiian violets (*Viola*, Violaceae): arctic origins, herbaceous ancestry and bird dispersal. *Evolution* **54**: 1521–1532.
- Barr TC. 1967.** Observations on ecology of caves. *American Naturalist* **101**: 475–492.
- Barr TC. 1968.** Cave ecology and the evolution of troglobites. *Evolutionary Biology* **2**: 35–102.
- Barr TC, Holsinger JR. 1985.** Speciation in cave faunas. *Annual Review of Ecology and Systematics* **16**: 313–337.
- Brower AVZ. 1994.** Phylogeny of *Heliconius* butterflies inferred from mitochondrial DNA sequences (Lepidoptera: Nymphalidae). *Molecular Phylogenetics and Evolution* **3**: 159–174.
- Brower AVZ, DeSalle R. 1998.** Patterns of mitochondrial versus nuclear DNA sequence divergence among nymphalid butterflies: the utility of *wingless* as a source of characters for phylogenetic inference. *Insect Molecular Biology* **7**: 73–82.
- Butler AG. 1880.** On two small consignments of Lepidoptera from the Hawaiian Islands. *Entomologist's Monthly Magazine* **17**: 6–9.
- Butler AG. 1881.** On a collection of nocturnal Lepidoptera from the Hawaiian Islands. *Annual Magazine of Natural History* **7**: 317–333.
- Contreras-Díaz HG, Moya O, Oromi P, Juan C. 2007.** Evolution and diversification of the forest and hypogean ground-beetle genus *Trechus* in the Canary Islands. *Molecular Phylogenetics and Evolution* **42**: 687–699.
- Desutter-Grandcolas L, Grandcolas P. 1996.** The evolution toward troglobitic life: a phylogenetic reappraisal of climatic relict and local habitat shift hypotheses. *Mémoires de Biospéologie* **23**: 57–63.
- Funk VA, Wagner WL. 1995.** Biogeographic patterns in the Hawaiian Islands. In: Wagner WL, Funk VA, eds. *Hawaiian biogeography: evolution on a hot spot archipelago*. Washington: Smithsonian Institution Press, 379–419.
- Gould SJ, Vrba ES. 1982.** Exaptation – a missing term in the science of form. *Paleobiology* **8**: 4–15.
- Harrison RG. 1998.** Linking evolutionary pattern and process. In: Howard DJ, Berlocher SH, eds. *Endless forms: species and speciation*. Oxford: Oxford University Press, 19–31.
- Hoch H, Howarth FG. 1999.** Multiple cave invasions by species of the planthopper genus *Oliarus* in Hawaii (Homoptera: Fulgoroidea: Cixiidae). *Zoological Journal of the Linnean Society* **127**: 453–475.

- Holland BS, Cowie RH. 2007.** A geographic mosaic of passive dispersal: population structure in the endemic Hawaiian amber snail *Succinea caduca* (Mighels, 1845). *Molecular Ecology* **16**: 2422–2435.
- Holloway JD. 1977.** The Lepidoptera of Norfolk Island: their biogeography and ecology. In: Schimitschek E, Spencer KA, eds. *Series entomologica*, Vol. 13. The Hague: Dr. W. Junk B.V.
- Howarth FG. 1972.** Cavernicoles in lava tubes on the island of Hawaii. *Science* **175**: 325–326.
- Howarth FG. 1973.** Cavernicolous fauna of Hawaiian lava tubes. 1. Introduction. *Pacific Insects* **15**: 139–151.
- Howarth FG. 1980.** The zoogeography of specialized cave animals: a bioclimatic model. *Evolution* **34**: 394–406.
- Howarth FG. 1981.** Non-relictual troglobites in the tropical Hawaiian caves. In: Beck BF, ed. *Proceedings of the 8th International Congress of Speleology*, Vol. 2. Kentucky: Bowling Green, 539–541.
- Howarth FG. 1983.** Ecology of cave arthropods. *Annual Review of Entomology* **28**: 365–389.
- Howarth FG. 1987.** The evolution of non-relictual tropical troglobites. *International Journal of Speleology* **16**: 1–16.
- Howarth FG. 1993.** High-stress subterranean habitats and evolutionary change in cave-inhabiting arthropods. *American Naturalist* **142**: S65–S77.
- Howarth FG, James SA, McDowell W, Preston DJ, Imada CT. 2007.** Identification of roots in lava tube caves using molecular techniques: implications for conservation of cave arthropod faunas. *Journal of Insect Conservation* **11**: 251–261.
- Howarth FG, Stone FD. 1990.** Elevated carbon dioxide levels in Bayliss Cave, Australia: implications for the evolution of obligate cave species. *Pacific Science* **44**: 207–218.
- Magnacca KN, Danforth BN. 2006.** Evolution and biogeography of native Hawaiian *Hylaeus* bees (Hymenoptera: Colletidae). *Cladistics* **22**: 393–411.
- Magnacca KN, Danforth BN. 2007.** Low nuclear DNA variation supports a recent origin of Hawaiian *Hylaeus* bees (Hymenoptera: Colletidae). *Molecular Phylogenetics and Evolution* **43**: 908–915.
- Megens HJ, van Moorsel CHM, Piel WH, Pierce NE, de Jong R. 2004.** Tempo of speciation in a butterfly genus from the Southeast Asian tropics, inferred from mitochondrial and nuclear DNA sequence data. *Molecular Phylogenetics and Evolution* **31**: 1181–1196.
- Meyrick E. 1899.** Macrolepidoptera. In: Sharp D, ed. *Fauna Hawaiiensis*, Vol. 1. Cambridge: Cambridge University Press, 123–275.
- Meyrick E. 1904.** Supplement to Macrolepidoptera. In: Sharp D, ed. *Fauna Hawaiiensis*, Vol. 3. Cambridge: Cambridge University Press, 345–366.
- Nixon KC. 1999.** The parsimony ratchet, a new method for rapid parsimony analysis. *Cladistics – The International Journal of the Willi Hennig Society* **15**: 407–414.
- Peck SB, Finston TL. 1993.** Galapagos islands troglobites: the question of tropical troglobites, parapatric distributions with eyed-sister-species, and their origin by parapatric speciation. *Mémoires de Biospéologie* **20**: 19–37.
- Peterson DW, Holcomb RT, Tilling RT, Christianson RL. 1994.** Development of lava tubes in the light of observations at Mauna Ulu, Kilauea Volcano, Hawaii. *Bulletin of Volcanology* **56**: 343–360.
- Poole RW. 1989.** *The Noctuidae, Part 2. Lepidopterorum catalogus (New Series), Fascicle 118*. Leiden, New York: E. J. Brill/Flora & Fauna Publications.
- Posada D, Crandall KA. 1998.** Modeltest: testing the model of DNA substitution. *Bioinformatics* **14**: 817–818.
- Price JP, Clague DA. 2002.** How old is the Hawaiian biota? Geology and phylogeny suggest recent divergence. *Proceedings of the Royal Society of London. Series B. Biological Sciences* **269**: 2429–2435.
- Rivera MAJ, Howarth FG, Taiti S, Roderick GK. 2002.** Evolution in Hawaiian cave-adapted isopods (Oniscidea: Philosciidae): vicariant speciation or adaptive shifts? *Molecular Phylogenetics and Evolution* **25**: 1–9.
- Roderick GK, Gillespie RG. 1998.** Speciation and phylogeography of Hawaiian terrestrial arthropods. *Molecular Ecology* **7**: 519–531.
- Roff DA. 1990.** The evolution of flightlessness in insects. *Ecological Monographs* **60**: 389–421.
- Roff DA. 1994.** The evolution of flightlessness – is history important? *Evolutionary Ecology* **8**: 639–657.
- Ronquist F, Huelsenbeck JP. 2003.** MrBayes 3: Bayesian phylogenetic inference under mixed models. *Bioinformatics* **19**: 1572–1574.
- Sattler K. 1991.** A review of wing reduction in Lepidoptera. *Bulletin of the British Museum of Natural History (Entomology)* **60**: 243–288.
- Sbordoni V. 1982.** *Advances in speciation of cave animals*. New York: A.R. Liss.
- Sbordoni V, Allegrucci G, Cesaroni D. 2000.** Population genetic structure, speciation and evolutionary rates in cave dwelling organisms. In: Wilkens H, Culver DC, Humphreys WF, eds. *Ecosystems of the world*, Vol. 30. Oxford: Elsevier Science Ltd., 453–477.
- Shaw KL. 2002.** Conflict between nuclear and mitochondrial DNA phylogenies of a recent species radiation: what mtDNA reveals and conceals about modes of speciation in Hawaiian crickets. *Proceedings of the National Academy of Sciences of the United States of America* **99**: 16122–16127.
- Sikes DS, Lewis PO. 2001.** *PAUPRat: a tool to implement Parsimony Ratchet searches using PAUP**. Storrs: Department of Ecology and Evolutionary Biology, University of Connecticut.
- Simon C, Frati F, Beckenbach A, Crespi B, Liu H, Flook P. 1994.** Evolution, weighting, and phylogenetic utility of mitochondrial gene sequences and a compilation of conserved polymerase chain reaction primers. *Annals of the Entomological Society of America* **87**: 651–701.
- Stamatakis A. 2006.** RAxML-VI-HPC: maximum likelihood-based phylogenetic analyses with thousands of taxa and mixed models. *Bioinformatics* **22**: 2688–2690.
- Swofford DL. 2002.** *PAUP* Version 4.0b10*. Sunderland, MA: Sinauer Associates, Inc.
- Yanoviak SP, Dudley R, Kaspari M. 2005.** Directed aerial descent in canopy ants. *Nature* **433**: 624–626.

Yoshimatsu S. 1995. *Schrankia costastrigalis* (Stephens) (Lepidoptera, Noctuidae) utilizing underground spaces. *Japanese Journal of Entomology* **63**: 541–550.

Zimmerman EC. 1958. *Insects of Hawaii, Vol. 7: Macrolepidoptera*. Honolulu: University of Hawaii Press.

Zimmerman EC. 1978. *Insects of Hawaii. Vol. 9 (2): Microlepidoptera*. Honolulu: University of Hawaii Press.

APPENDIX

The following is a list of *Schrankia* specimens included in the phylogenetic analysis

Voucher	Species	Sex	Locality	GenBank accession no: COI	GenBank accession no: COII	GenBank accession no: <i>wingless</i>
03A15	<i>S. howarthi</i>	M	HI: Hawaii, Kazumura Cave	EU309797	EU418124	EU418186
04A04	<i>S. undescribed sp.</i>	M	French Polynesia: Tahiti	EU309798	EU418125	EU418187
04A26	<i>S. altivolans</i>	F	HI: Maui, Kula	EU309799	EU418126	EU418188
04A27	<i>S. altivolans</i>	F	HI: Maui, Kula	EU309800	EU418127	EU418189
04A38	<i>S. altivolans</i>	M	HI: Hawaii, Kaumana Cave	EU309801	EU418128	EU418190
04A39	<i>S. howarthi</i>	M	HI: Hawaii, Kaumana Cave	EU309802	EU418129	EU418191
04A49	<i>S. howarthi</i>	M	HI: Hawaii, Saddle Rd & Tree Planting Rd	EU309803	EU418130	EU418192
04A54	<i>S. altivolans</i>	M	HI: Hawaii, Stainback Hwy & Tree Planting Rd	EU309804	EU418131	EU418193
04A56	<i>S. howarthi</i>	M	HI: Hawaii, Stainback Hwy & Tree Planting Rd	EU309805	EU418132	EU418194
04A57	<i>S. altivolans</i>	M	HI: Hawaii, Stainback Hwy & Tree Planting Rd	EU309806	EU418133	EU418195
04A66	<i>S. howarthi</i>	M	HI: Hawaii, Emesine Cave	EU309807	EU418134	EU418196
04A70	<i>S. altivolans</i>	M	HI: Maui, HNP, Hosmer Grove	EU309808	EU418135	EU418197
04A73	<i>S. altivolans</i>	M	HI: Maui, HNP, Hosmer Grove	EU309809	EU418136	EU418198
04A86	<i>S. howarthi</i>	M	HI: Maui, HNP, Holua	EU309810	EU418137	EU418199
04A91	<i>S. altivolans</i>	M	HI: Hawaii, HVNP, Mauna Loa Strip Rd	EU309811	EU418138	EU418200
04A95	<i>S. altivolans</i>	M	HI: Hawaii, HVNP, Mauna Loa Strip Rd	EU309812	EU418139	EU418201
04A98	<i>S. altivolans</i>	F	HI: Hawaii, Manuka St. Park	EU309813	EU418140	EU418202
05A03	<i>S. altivolans</i>	M	HI: Kauai, Hanalei Ridge	EU309814	EU418141	EU418203
05A10	<i>S. howarthi</i>	F	HI: Hawaii, Kaumana Cave	EU309815	EU418142	EU418204
05A11	<i>S. howarthi</i>	M	HI: Hawaii, Kaumana Cave	EU309816	EU418143	EU418205
05A14	<i>S. howarthi</i>	M	HI: Hawaii, Kaumana Cave	EU309817	EU418144	EU418206
05A15	<i>S. howarthi</i>	F	HI: Hawaii, Kaumana Cave	EU309818	EU418145	EU418207
05A24	<i>S. howarthi</i>	M	HI: Hawaii, Stainback Hwy & Tree Planting Rd	EU309819	EU418146	EU418208
05A32	<i>S. howarthi</i>	M	HI: Hawaii, Stainback Hwy & Tree Planting Rd	EU309820	EU418147	EU418209
05A34	<i>S. howarthi</i>	M	HI: Hawaii, Emesine Cave	EU309821	EU418148	EU418210
05A36	<i>S. howarthi</i>	M	HI: Hawaii, Emesine Cave	EU309822	EU418149	EU418211
05A61	<i>S. howarthi</i>	F	HI: Hawaii, Puu Waawaa Cave	EU309823	EU418150	EU418212
05A62	<i>S. howarthi</i>	F	HI: Hawaii, Puu Waawaa Cave	EU309824	EU418151	EU418213
05A63	<i>S. howarthi</i>	M	HI: Hawaii, Puu Waawaa Cave	EU309825	EU418152	EU418214
05A64	<i>S. howarthi</i>	M	HI: Hawaii, Puu Waawaa Cave	EU309826	EU418153	EU418215

05A68	<i>S. altivolans</i>	M	HI: Hawaii, Kohala Forest Reserve	EU309827	EU418154	EU418216
05A69	<i>S. altivolans</i>	M	HI: Hawaii, Kohala Forest Reserve	EU309828	EU418155	EU418217
05A77	<i>S. altivolans</i>	M	HI: Kauai, Kokee St. Park	EU309829	EU418156	EU418218
05A78	<i>S. altivolans</i>	F	HI: Kauai, Kokee St. Park	EU309830	EU418157	EU418219
05A92	<i>S. altivolans</i>	M	HI: Kauai, Kokee St. Park	EU309831	EU418158	EU418220
06A35	<i>S. altivolans</i>	F	HI: Hawaii, Saddle Rd & Tree Planting Rd	EU309832	EU418159	EU418221
06A39	<i>S. howarthi</i>	M	HI: Hawaii, Saddle Rd & Tree Planting Rd	EU309833	EU418160	EU418222
06A41	<i>S. howarthi</i>	M	HI: Hawaii, Kula Kai Cave	EU309834	EU418161	EU418223
06A43	<i>S. howarthi</i>	M	HI: Hawaii, Kula Kai Cave	EU309835	EU418162	EU418224
06A51	<i>S. howarthi</i>	M	HI: Hawaii, HVNP, near Thurston Lava Tube	EU309836	EU418163	EU418225
06A52	<i>S. altivolans</i>	M	HI: Hawaii, HVNP, near Thurston Lava Tube	EU309837	EU418164	EU418226
06A68	<i>S. howarthi</i>	M	HI: Hawaii, HVNP, Kipuka Puaulu	EU309838	EU418165	EU418227
06A70	<i>S. altivolans</i>	M	HI: Hawaii, HVNP, Kipuka Puaulu	EU309839	EU418166	EU418228
06A73	<i>S. howarthi</i>	M	HI: Hawaii, Kazumura Cave	EU309840	EU418167	EU418229
06A77	<i>S. altivolans</i>	M	HI: Hawaii, HVNP, Mauna Loa Strip Rd	EU309841	EU418168	EU418230
06A83	<i>S. howarthi</i>	F	HI: Hawaii, Emesine Cave	EU309842	EU418169	EU418231
06A91	<i>S. howarthi</i>	F	HI: Hawaii, HVNP, Ainahou Cave	EU309843	EU418170	EU418232
06B01	<i>S. altivolans</i>	M	HI: Oahu, Waianae Mtns.	EU309844	EU418171	EU418233
06B09	<i>S. howarthi</i>	M	HI: Maui, Makawao Forest Reserve	EU309845	EU418172	EU418234
06B12	<i>S. howarthi</i>	M	HI: Maui, Makawao Forest Reserve	EU309846	EU418173	EU418235
06B45	<i>S. altivolans</i>	M	HI: Maui, Puu Kukui	EU309847	EU418174	EU418236
06B46	<i>S. altivolans</i>	M	HI: Maui, Puu Kukui	EU309848	EU418175	EU418237
06B55	<i>S. howarthi</i>	M	HI: Maui, Puu Kukui	EU309849	EU418176	EU418238
06B63	<i>S. howarthi</i>	M	HI: Maui, East Maui Cave	EU309850	EU418177	EU418239
06B66	<i>S. howarthi</i>	M	HI: Maui, East Maui Cave	EU309851	EU418178	EU418240
06B76	<i>S. howarthi</i>	F	HI: Hawaii, Kaumana Cave	EU309852	EU418179	EU418241
06B77	<i>S. howarthi</i>	M	HI: Hawaii, Kaumana Cave	EU309853	EU418180	EU418242
06B80	<i>S. altivolans</i>	M	HI: Hawaii, Kaumana Cave	EU309854	EU418181	EU418243
06B85	<i>S. costaestrigalis</i>	M	Spain: Mallorca, Sa Roca	EU309855	EU418182	EU418244
06B88	<i>Hypena californica</i>	F	CA: San Mateo Co.	EU309856	EU418183	EU418245
LA06	<i>S. howarthi</i>	M	HI: Hawaii, HVNP, Ainahou Cave	EU309857	EU418184	EU418246
LA07	<i>S. howarthi</i>	M	HI: Hawaii, HVNP, Ainahou Cave	EU309858	EU418185	EU418247