

A Monograph of the Family
Arrhenophanidae
(Lepidoptera: Tineoidea)

DONALD R. DAVIS

SMITHSONIAN CONTRIBUTIONS TO ZOOLOGY • NUMBER 620

SERIES PUBLICATIONS OF THE SMITHSONIAN INSTITUTION

Emphasis upon publication as a means of "diffusing knowledge" was expressed by the first Secretary of the Smithsonian. In his formal plan for the Institution, Joseph Henry outlined a program that included the following statement: "It is proposed to publish a series of reports, giving an account of the new discoveries in science, and of the changes made from year to year in all branches of knowledge." This theme of basic research has been adhered to through the years by thousands of titles issued in series publications under the Smithsonian imprint, commencing with *Smithsonian Contributions to Knowledge* in 1848 and continuing with the following active series:

Smithsonian Contributions to Anthropology
Smithsonian Contributions to Botany
Smithsonian Contributions to the Earth Sciences
Smithsonian Contributions to the Marine Sciences
Smithsonian Contributions to Paleobiology
Smithsonian Contributions to Zoology
Smithsonian Folklife Studies
Smithsonian Studies in Air and Space
Smithsonian Studies in History and Technology

In these series, the Institution publishes small papers and full-scale monographs that report the research and collections of its various museums and bureaux or of professional colleagues in the world of science and scholarship. The publications are distributed by mailing lists to libraries, universities, and similar institutions throughout the world.

Papers or monographs submitted for series publication are received by the Smithsonian Institution Press, subject to its own review for format and style, only through departments of the various Smithsonian museums or bureaux, where the manuscripts are given substantive review. Press requirements for manuscript and art preparation are outlined on the inside back cover.

Lawrence M. Small
Secretary
Smithsonian Institution

SMITHSONIAN CONTRIBUTIONS TO ZOOLOGY • NUMBER 620

A Monograph of the Family Arrhenophanidae
(Lepidoptera: Tineoidea)

Donald R. Davis



Smithsonian Institution Press

Washington, D.C.

2003

ABSTRACT

Davis, Donald R. A Monograph of the Family Arrhenophanidae (Lepidoptera: Tineoidea). *Smithsonian Contributions to Zoology*, number 620, 80 pages, 255 figures, 9 maps, 2003.—The systematics, morphology, distribution, and generic phylogeny are summarized for the family. A single autapomorphy, the terminal position of the female ostium at the caudal end of the prolonged and partially separated eighth sternum, distinguishes Arrhenophanidae from its sister family Psychidae. The latter family is further characterized by at least two larval autapomorphies: the presence of four pairs of ventral epipharyngeal setae on the labrum and the complete fusion of the prothoracic lateral pinaculum bearing the spiracle with the pronotum. Cladistic analysis, based largely on antennal and venational characters, of the five recognized genera positions the southeast Asian genus *Palaeophanes* basally within the family, followed by the Australian genus *Notiophanes*. The widespread Neotropical genera *Arrhenophanes* and *Dysoptus* were found to be the most derived. Larvae of four species, *Arrhenophanes perspicilla* (Stoll), *Cnissostages oleagina* Zeller, *Dysoptus argus*, new species, and *Dysoptus prolatus*, new species, have been reared. In all known species the larvae construct tough, silken cases and feed on wood decay fungi (Coriolaceae, Hymenochaetaceae, and Polyporaceae).

The family occurs in wet tropical forests of southeast Asia (*Palaeophanes*, four species), Australia (*Notiophanes fuscata*), and through much of the Neotropical Region (except the West Indies; *Arrhenophanes*, *Cnissostages*, *Dysoptus*, 21 species). Two genera, *Notiophanes* Davis and Edwards and *Palaeophanes* Davis, and the following 18 species are described as new: *Cnissostages osae* Davis, *Dysoptus acuminatus* Davis, *D. argus* Davis, *D. asymmetricus* Davis, *D. avittus* Davis, *D. bilobus* Davis, *D. denticulatus* Davis, *D. fasciatus* Davis, *D. pentalobus* Davis, *D. prolatus* Davis, *D. pseudargus* Davis, *D. sparsimaculatus* Davis, *D. spilacris* Davis, *Notiophanes fuscata* Davis and Edwards, *Palaeophanes brevispina* Davis, *P. lativalva* Davis, *P. taiwanensis* Davis, and *P. xoutha* Davis.

OFFICIAL PUBLICATION DATE is handstamped in a limited number of initial copies and is recorded in the Institution's annual report, *Annals of the Smithsonian Institution*. SERIES COVER DESIGN: The coral *Montastrea cavernosa* (Linnaeus).

Library of Congress Cataloging-in-Publication Data

Davis Donald R. (Donald Ray)

A monograph of the family Arrhenophanidae (Lepidoptera: Tineoidea) / Donald R. Davis

p. cm.—(Smithsonian contributions to zoology ; no. 620)

Includes bibliographical references (p.).

I. Arrhenophanidae. I. Title. II. Series.

QL1 .S54 no. 620 [QL561.A865] 590 s—dc21 [595.78]

2002030622

∞ The paper used in this publication meets the minimum requirements of the American National Standard for Permanence of Paper for Printed Library Materials Z39.48—1984.

Contents

	<i>Page</i>
Introduction	1
Acknowledgments	1
Material and Methods	2
Biology of the Arrhenophanidae	3
Distribution	3
Life History	4
Phylogeny of the Arrhenophanidae	6
Phylogenetic Analysis	6
Characters Used in the Analysis	7
ARRHENOPHANIDAE	9
List of Species	11
Key to the Genera of Arrhenophanidae	17
<i>Palaeophanes</i> , new genus	17
Key to the Species of <i>Palaeophanes</i>	18
<i>Palaeophanes lativalva</i> , new species	18
<i>Palaeophanes taiwanensis</i> , new species	19
<i>Palaeophanes</i> sp.	20
<i>Palaeophanes brevispina</i> , new species	20
<i>Palaeophanes xoutha</i> , new species	21
<i>Notiophanes</i> Davis and Edwards, new genus	21
<i>Notiophanes fuscata</i> Davis and Edwards, new species	22
<i>Cnissostages</i> Zeller	22
Key to the Species of <i>Cnissostages</i>	23
<i>Cnissostages oleagina</i> Zeller	24
<i>Cnissostages mastictor</i> Bradley	26
<i>Cnissostages osae</i> , new species	27
<i>Dysoptus</i> Walsingham	28
Key to the Species of <i>Dysoptus</i>	29
<i>Dysoptus fasciatus</i> , new species	30
<i>Dysoptus pseudargus</i> , new species	30
<i>Dysoptus prolatus</i> , new species	31
<i>Dysoptus sparsimaculatus</i> , new species	32
<i>Dysoptus denticulatus</i> , new species	33
<i>Dysoptus anachoreta</i> (Bradley), new combination	33
<i>Dysoptus chiquitus</i> (Busck), new combination	35
<i>Dysoptus tantalota</i> Meyrick	36
<i>Dysoptus probata</i> Walsingham	36
<i>Dysoptus bilobus</i> , new species	37
<i>Dysoptus pentalobus</i> , new species	38
<i>Dysoptus avittus</i> , new species	39
<i>Dysoptus asymmetricus</i> , new species	39
<i>Dysoptus acuminatus</i> , new species	40
<i>Dysoptus spilacris</i> , new species	40
<i>Dysoptus argus</i> , new species	42
<i>Arrhenophanes</i> Walsingham	43
Key to the Species of <i>Arrhenophanes</i>	44
<i>Arrhenophanes perspicilla</i> (Stoll)	44

Arrhenophanes volcanica Walsingham 53
Literature Cited 56
Figures 87–255 58

A Monograph of the Family Arrhenophanidae (Lepidoptera: Tineoidea)

Donald R. Davis

Introduction

The Arrhenophanidae are a small family of tineoid moths closely allied to the bagworm family Psychidae. Five genera and 26 species are described in this study, primarily from humid tropical forests of the Neotropical Region, Australia, and southeast Asia. Like many members of the Tineoidea, including Psychidae, their larvae construct silken cases within which pupation eventually occurs. All known arrhenophanid larvae are fungivorous, feeding either externally or by tunneling into various wood decay fungi of the families Coriolaceae, Hymenochaetaeaceae, and Polyporaceae. Adults often can be recognized superficially by their relatively broad wings (with a forewing length ranging from 4 to 33 mm), moderately long, upturned labial palpi that lack erect hairs, and minute haustella (usually undetectable without dissection). More significantly, the antennal rami of most arrhenophanid species are broader or more pectinated in the females than in the males (Figures 12–19). This is the reverse of the condition present in other lepidopterous families exhibiting antennal dimorphism. Arrhenophanidae are characterized by at least one autapomorphy, namely the terminal position of the female ostium at the caudal end of the prolonged and partially separated eighth sternum. Two synapomorphies of the male—the short, triangular apodemes of the eighth abdominal sternite and well-developed anellus—also distinguish Arrhenophanidae from most, if not all, members of its sister group, Psychidae.

Donald R. Davis, Department of Systematic Biology, Section of Entomology, National Museum of Natural History, Smithsonian Institution, Washington, D.C. 20560-0127.

Review Chairman: John M. Burns, Department of Systematic Biology, Division of Entomology, National Museum of Natural History, Smithsonian Institution, Washington, D.C. 20560-0127.

Reviewers: Edward D. Edwards, Division of Entomology, CSIRO, P.O. Box 1700, Canberra City, ACT 2601, Australia. Jerry A. Powell, Department of Entomology, 201 Wellman Hall, University of California, Berkeley, California 94720-0001. Gaden S. Robinson, Department of Entomology, The Natural History Museum, Cromwell Road, London SW7, 5BD, Great Britain.

As noted by Robinson (1988), the family has received little attention in the literature since its inception (Walsingham, 1913), with the exception of a paper by Bradley (1951) in which the genital morphology was discussed for the first time. Prior to the present study, only four genera (including one generic synonym proposed herein) and eight species were known (Davis, 1984, 1999; Becker, 1984), all from the Neotropical Region. Fieldwork conducted principally during the last two decades has resulted in the discovery of two new genera and 18 new species, including the first records of Arrhenophanidae from the Old World (Davis, 1991, 1998; Davis and Robinson, 1998). Additional taxa, including at least one and possibly more new genera, are known but cannot be described because of the lack of critical stages or specimens in better condition. The first Australian representative of this family (*Notiophanes fuscata* Davis and Edwards), a relatively large moth with a wing span of 59 mm (~2.5 inches), is described herein from a single female collected in 1998. This review clearly demonstrates that much more fieldwork is needed for this poorly collected family.

ACKNOWLEDGMENTS

I wish to thank several individuals who have assisted me during the course of this study by providing critical information, loans of specimens under their care, or other special assistance: Vitor O. Becker, Planaltina, D.F., Brazil; Marc E. Epstein, Smithsonian Institution, Washington, D.C.; E.D. Edwards and the late Ebbe S. Nielsen, CSIRO, Canberra, ACT, Australia; John B. Heppner, Florida State Collection of Arthropods, Gainesville, Florida; Daniel H. Janzen, University of Pennsylvania, Philadelphia, Pennsylvania; Jean-François Landry, Centre for Land and Biological Resources, Ottawa, Canada; Wolfram Mey, Museum für Naturkunde, Humboldt-Universität, Berlin, Germany; Eugenie Phillips, Instituto Nacional de Biodiversidad, Santo Domingo de Heredia, Costa Rica; Jerry A. Powell, University of California, Berkeley, California; John Rawlins, Carnegie Museum, Pittsburgh, Pennsylvania; Gaden

TABLE 1.—Temporal distribution of Arrhenophanidae at La Selva Biological Preserve, Costa Rica, January 1998 to June 1999.

Species	Jan	Feb	Mar	Apr	May	Jun	Jul	Aug	Sep	Oct	Nov	Dec	Jan	Feb	Mar	Apr	May	Jun
<i>Dysoptus bilobus</i>	—	5	6	13	3	16	5	5	8	5	5	2	1	6	—	6	5	4
<i>D. prolatus</i>	2	1	1	—	—	—	3	—	1	—	—	—	—	1	—	—	—	—
<i>D. spilacris</i>	—	—	1	14	2	16	11	—	—	2	6	1	1	2	—	—	—	13
<i>D. chiquitus</i>	—	—	—	—	—	—	—	1	—	—	—	—	—	—	—	1	—	—

S. Robinson and Kevin Tuck, The Natural History Museum, London, England. I am indebted to Vichai Malikul, Young Sohn, and George Venable, Entomology Section, Smithsonian Institution, and Rachel Collins for the artwork and graphics. Susann Braden of the Smithsonian Scanning Electron Microscope Laboratory and John Steiner of the Smithsonian Photographic Services assisted with the photographs. Patricia Gentili Poole of the Entomology Section, Smithsonian Institution, and Dan Cole of the Automatic Data Processing Program (Smithsonian Institution) were very helpful in plotting distributional data.

Fieldwork in Taiwan was supported by a grant from the Smithsonian Institution Fluid Research Fund. Shui-chen (Sally) Chiu, formerly of the Taiwan Agricultural Research Institute (TARI), Sheng-hua Lin Chow of the National Science Council of the Republic of China, Yua-i Chu of the National Taiwan University at Taipei, Ming-jou Lai, formerly of the Taiwan Natural History Museum in Taipei, and Jen-ren Shih assisted with travel arrangements in Taiwan. Mr. Jen was especially helpful in assisting the author during two and one-half months of fieldwork. Mr. Hsiau Yue Hwang of the Taiwan National Museum was likewise very supportive of the field work of J.B. Heppner in Taiwan. I also thank La Fundacion para el Desarrollo de las Ciencias Fisicas, Matematicas y Naturales of Venezuela and the Scholarly Studies Program of the Smithsonian Institution for their combined support of my fieldwork during 1984 at Cerro de la Neblina, Venezuela.

I particularly wish to acknowledge the contribution that the Arthropods of La Selva [ALAS] III project (supported by National Science Foundation grant DEB-9706976) and co-principal investigator John Longino have made to this study, and especially the parataxonomists at La Selva working on this project, Danilo Brenes, Nelci Oconitrillo, Maylin Paniagua, and Ronald Vargas. The trapping protocol for the 1998–1999 sampling period was designed by Jerry Powell. This was augmented by blacklight collecting at sheets by Powell, John Brown, Eugenie Phillips, David Wagner, and others. The directors and staff of the La Selva Biological Station also have been most helpful. Jack Korytowski, Smithsonian Institution Press, did the final editing and prepared the manuscript for publication.

Finally I acknowledge the cooperation of the institutions or individuals listed below along with their acronyms.

ANIC Australian National Insect Collection, CSIRO, Canberra, Australia
 BMNH The Natural History Museum (formerly the British Museum (Natural History)), London, England

CAS California Academy of Sciences, San Francisco, California, USA
 CMNH Carnegie Museum of Natural History, Pittsburgh, Pennsylvania, USA
 CNC The Canadian National Collections, Agriculture Canada, Ottawa, Canada
 CU Cornell University, Ithaca, New York, USA
 FSCA Florida State Collection of Arthropods, Gainesville, Florida, USA
 INBIO Instituto Nacional de Biodiversidad, Santo Domingo, Costa Rica
 MNHU Museum für Naturkunde, Humboldt-Universität, Berlin, Germany
 NMNH National Museum of Natural History, Smithsonian Institution, Washington, D.C., USA
 NMT National Museum of Taiwan, Taiwan
 UCB Essig Museum of Entomology, University of California, Berkeley, California, USA
 UCVM Instituto de Zoología Agrícola Facultad de Agronomía, Universidad Central de Venezuela, Maracay-Aragua, Venezuela.
 UFPR Universidade Federal do Paraná, Brazil
 USNM Collections of the National Museum of Natural History, Smithsonian Institution, Washington D.C., USA, including collections of the former United States National Museum
 VOB Vitor O. Becker, Planaltina, D.F., Brazil

MATERIAL AND METHODS

With the exception of a few specimens of *Arrhenophanes perspicilla*, *Dysoptus argus*, and *D. prolatus*, which were reared, it is believed that all material examined in this study were collected at lights. Almost all Arrhenophanidae collected during the ALAS III Microlepidoptera survey at the La Selva Biological Preserve were taken with 8-watt Entotech® blacklight traps during an 18-month period, from January 1998 through June 1999 (Table 1). Prior to the light-trap survey, approximately 280 collection samples from blacklight sheets were made during approximately 1800–2300 hours between January 1993 and June 1996. It is of interest to note that the latter effort yielded few Arrhenophanidae. Details relating to the quantitative blacklight sampling conducted during this survey during the entire 18-month period may be accessed through the ALAS website (<http://viceroyn.eeb.uconn.edu/ALAS/ALAS.html>) under “collection data for ALAS quantitative samples.” Because several families of Microlepidoptera were the focal taxa for one portion of this survey, the traps were covered with a wire cage having a mesh size of 0.5 inch [1.27 cm] to exclude large insects that might otherwise damage the focal taxa. Traps were operated in pairs: one suspended in the canopy approximately 20–35 m high, and another on the ground beneath it. On each night of sampling, one trap pair was run. Trapping was conducted on two or three nights per week, rotating the paired traps among the six sites listed below. For 14 of

the 372 individual samples, the traps malfunctioned when the fluorescent light failed to operate. The data provided refer to the following information: e.g., 7 [site number], SOR [La Selva trail name "Sendero Oriental"] 750 [meters from main laboratory clearing], 778, 1618 [Geographic Information System coordinates], canopy [trap location]. Trap locations that yielded Arrhenophanidae are marked with an asterisk.

- 7, SOR [Sendero Oriental] 750, 778, 1618, canopy
- *8, SOR 750, 789, 1642, ground
- 9, CCC [Camino Circular Cercano] 550, 1019, 898, canopy
- *10, CCC 550, 1035, 876, ground
- 11, Arboleda [Arboretum] 896, 469, canopy
- *12, Arboleda, 881, 461, ground
- 13, CES [Camino Experimental Sur] 350, 566, 464, canopy
- *14, CES 350, 529, 485, ground
- 15, STR [Sendero Tres Rios] 650, 0, 0, canopy
- *16, STR 650, 0, 0, ground
- 17, STR 2000, 912, -675, canopy
- *18, STR 1800, 901, -664, ground

All La Selva specimens collected from these sites bear a three-part label: e.g., "L [light trap]/14 [trap site]/ 411 [a unique sequential number for all blacklight samples commencing with the ALAS I survey of 1993]."

Because the bases of the male valvae are firmly joined together and cannot be easily spread during slide preparation, lateral and ventral views of the genitalia were drawn while positioned in a glycerin-well slide before mounting in a permanent ventral position on a microslide. Before mounting in balsam, usually the right valva was removed and positioned along the genitalia in a lateral (mesal) view. Female genitalia were likewise drawn in glycerin before mounting, in order to illustrate a lateral view of the eighth abdominal segment. Certain larval and adult structures were first cleaned after being softened in 10% potassium hydroxide, transferred to absolute ethanol, and critical-point dried before sputter coating with gold palladium and photographing with a Hitachi 570 scanning electron microscope. Antennal figures were first mounted on microslides and photographed, with the images later scanned into Adobe Photoshop. Distributional maps were prepared using the mapping program ArcView and Adobe Illustrator.

Biology of the Arrhenophanidae

DISTRIBUTION

Arrhenophanidae typically inhabit tropical, mostly lowland rainforests. The greatest concentration of taxa (three genera, 21 species) occurs in the Neotropical Region, with one genus and five species (including one unnamed species) also known from southeast Asia, and one genus and one species from Queensland, Australia. No records of the family are known from the Ethiopian Region, but it should be emphasized that the African continent remains poorly surveyed for most families of Microlepidoptera. It seems likely that Arrhenophanidae will be found eventually in some wet forests of equatorial Africa. Conse-

quently, it seems premature to attempt a biogeographical analysis of this still poorly surveyed family. Current collection data demonstrate a central Pacific basin distribution, which may reflect only part of a suspected broader tropical distribution more similar to that of the tineid subfamily Harmacloninae (Davis, 1998a). Undoubtedly, there is much to discover; a great majority of the new taxa described in this report, including all Old World taxa, were not collected until relatively recently.

The New World distribution of this family approximates the limits of the Neotropical Region, with the notable exception of its absence from the West Indies. A single adult male of questionable affinities, collected in Cuba and now deposited in the NMNH, might represent an undescribed genus of Arrhenophanidae. The specimen was collected 10 July 1934 on "El Pan Mt." [Pan de Matanzas, approximately 11 km west of Matanzas], Matanzas Province, Cuba. The family affinities of this insect will remain doubtful until more specimens, especially females, are collected. Unique males of possibly other undescribed arrhenophanid genera also have been examined from both South America and southeast Asia. As is true for the Cuban species, their family relationships cannot be determined until more material, particularly females, are available.

The genus *Arrhenophanes* contains two of the largest, and consequently most frequently collected, Neotropical members of the family. Both species occur widely through much of the lowland rainforests of Central and South America (Maps 8, 9). *Cnissostages* includes three species, with *C. oleagina* the most frequently collected and widespread member, ranging from Mexico to southern Brazil (Map 2). Although equalling *Arrhenophanes perspicilla* in body size, *Cnissostages mastictor* seldom has been collected. The few records known are from Costa Rica, Ecuador, and Peru (Map 3).

Dysoptus (= *Ecpathophanes*), with 16 species, constitutes the most speciose genus of Arrhenophanidae. *Dysoptus argus* and *D. chiquitus* have been the most widely collected species, with records of the former (Map 7) centered around the Amazonian region of Brazil, French Guiana, Guyana, Peru, and Brazil, and the latter (Map 5) extending from Costa Rica to Mato Grosso, Brazil. Other members of *Dysoptus* are probably as widespread through lowland rainforests but are rarely collected by nonspecialists. Because Arrhenophanidae was one of several focal taxa sampled during the recent ALAS III (La Selva, Costa Rica) Microlepidoptera survey, numerous examples were collected in ultraviolet light traps (Table 1). The most commonly encountered arrhenophanid during this 18-month survey was *Dysoptus bilobus* (95 moths), followed by *D. spilacris* (69), *D. prolatus* (9), and *D. chiquitus* (2). *Arrhenophanes perspicilla* also has been collected at La Selva but not during the 1998–1999 survey. Its absence from the trap samples was probably caused by the 0.5 inch mesh screen over the traps, which was intended to exclude large insects.

The genus *Palaeophanes* is known from scattered sites in southeast Asia (Map 1), notably Taiwan (*P. latalvalva*, *P. taiwanensis*), Brunei (*P. brevispina*), and Malaysia (*P. xoutha*, *P.*

sp.). Considering the few specimens collected during the last decade, one should expect many more species from this region. As recently as 1998, the first member of this family, *Notiophanes fuscata*, was collected in Queensland, Australia. As with *Cnissostages mastictor*, it is surprising that such a relatively large moth (wing span to 65 mm) had escaped detection for so long. Either these species are relatively rare in nature, or they are less attracted to lights. The unique female of *N. fuscata* was collected at light in an upland (tableland) rainforest at an elevation of 1100 m.

LIFE HISTORY

Because mycophagy (including both fungivory and lichenivory) has developed independently in relatively few, taxonomically isolated clades within ditrysian Lepidoptera, the presence of this habit is generally considered to be a probable apomorphic specialization within each particular clade (Rawlins, 1984). Among the lower, nonditrysian Lepidoptera, for example, only the larvae of Micropterigidae and Mnesarchaeidae feed primarily on cryptogamic plant hosts (Powell et al., 1998). Their larvae feed externally on various bryophytes, possibly fungal hyphae and leaf litter, with occasional feeding on some dicotyledonous genera reported for *Micropterix* in Europe (Lorenz, 1961; Heath, 1976; Carter and Dugdale, 1982). The mandibulate adults of Micropterigidae consume pollen of many angiosperm families (Heath, 1976) and fern spores (Kristensen, 1998; Wagner and Davis, unpublished). Ancestral Tineoidea most likely arose from some group within the monotrysian heteroneura (Nielsen, 1985; Davis, 1986), whose larvae today feed initially or entirely on living angiosperms. Thus, although mycophagy probably represents the plesiomorphic trait within the Tineoidea (Powell, 1980), this habit may have been derived from an ancestor whose larvae fed on higher, living plants. Within the Tineoidea, mycophagy has developed in several subfamilies of Tineidae and Psychidae (Rawlins, 1984; Robinson and Nielsen, 1993; Davis and Robinson, 1998). Both fungivory and lichenivory as well as detritivory (feeding on dead leaves) occur within Tineidae and Psychidae (Hättenschwiler, 1985). Subterranean root feeding by larvae of Acrolophidae has been frequently mentioned in the literature (Hasbrouck, 1964), with only isolated instances of fungivory (Davis, 1990), lichenivory (Davis and Hogue, 1992), and coprophagy (Davis et al., 1986; Davis, 1987; Davis and Milstrey, 1988) reported. Fungi may be a major food preference, especially among rainforest species. The actual food resource of those genera of Acrolophidae reported as guanophiles (Davis, 1987) remains questionable and could consist of either nitrogenous nutrients in the bat guano or in fungal mycelia, or both.

Little is known of the life history of the Arrhenophanidae. The hosts of only two species, *Arrhenophanes perspicilla* (Busck, 1912; Hoffmann, 1931; Biezanko, 1961) and *Cnissostages oleagina* (Zeller, 1863), have been reported, and the rearing of *Dysoptus prolatus*, new species, is described herein. The

larvae are fungivorous, boring in various species of wood-decay fungi (Corioliaceae, Hymenochaetaceae, Polyporaceae). Busck reported the larvae to be gregarious, with several dark brown, moderately flattened cases protruding from a single fungus. From the attached cases the larvae construct long, irregular, silk-lined tunnels into the fungus. The larva of *Dysoptus prolatus* constructs firm, slender, cylindrical cases that project out from the host fungus (Figure 80) and moves onto the lower surfaces of the shelf fungus. Immediately prior to pupation, larvae of all Arrhenophanidae apparently close the attached, anterior end of the case and invert their body, with the head directed toward the flattened or tapered posterior end. A similar larval behavior is typical for almost all Psychidae (Davis, 2000b; Davis and Robinson, 1998), as well as some Tineidae and most species of Coleophoridae. During eclosion, the pupa protrudes approximately one-half its length from the case. The host association of one other arrhenophanid, *Dysoptus argus*, is noted in the present report. That species was reared by V.O. Becker in Brazil from a species of *Fomes* (Corioliaceae).

Because mycophagous larvae dwell in moist, enclosed microhabitats where entomopathogens abound, they have developed various larval specializations as protection against most pathogens (Rawlins, 1984). The silk-lined tunnel and case constructed by *Arrhenophanes perspicilla*, which help to protect the enclosed larva from parasites, predators, and pathogenic debris, are typical examples of such specializations. The dense spiracular filters of the larva (Figures 75, 76) also serve to prevent entry of fungal spores and other detritus into the tracheal system.

Adults are nocturnal, phototropic, nonfeeding, and probably short lived as suggested by their extremely reduced haustella (Figures 3–10). Collection data for the most commonly encountered species also indicate that moths may emerge throughout the year, but possibly with peak periods. The two most common arrhenophanids (*Dysoptus bilobus*, *D. spilacris*) sampled during the La Selva survey (Table 1) were collected in every, or almost every, month of the year, with peak captures in April, June, and July (for *D. spilacris*). Emergence during June was noted to be particularly high for these two species, with 21% of the 18-month sample of *D. bilobus* and 42% of *D. spilacris* occurring during that month.

Precipitation recorded at the "Puente" (bridge) station at La Selva from 1982 to 1991 showed the lowest weekly average occurred between 26 March and 1 April, with the highest average during the week of 20–26 August. During this nine-year period, the wet season began rather abruptly during the second week of May (Sanford et al., 1994). Monthly precipitation rates recorded at the same station (OTS (Organization for Tropical Studies) website: www.ots.ac.cr/en/laselva/meteorological.shtml) during 1998–1999 sometime show highly variable amounts of rainfall between comparable months. In 1998 the lowest monthly precipitation was recorded during February (33.60 mm), with April totaling 110.30 mm, compared with 148.70 mm and 419.30 mm, respectively, for 1999. Precipita-

tion during March (145.00/136.80 mm), May (304.80/273.10 mm), and June (453.40/394.50 mm) for 1998/1999, respectively, were more similar. Thus, the peak adult collection periods of April and June for *Dysoptus bilobus* and *D. spilacris* may be only partially the result of increase precipitation, and the sharp decline in samples during May, with all traps operating, appears unexplained.

The ALAS III data also indicate, at least for some species, that either the flight ability, relative attraction to blacklight, or activity period of the females differ significantly from that of the males. Of the 175 records tabulated in Table 1, only a single female (*D. spilacris*) was represented. An additional female of *Dysoptus prolatus* was reared in April 2001, along with five males. Collections of other Arrhenophanidae also have a similar paucity of females, with the females of several poorly sampled species unknown. Females comprise 19.3% (57 specimens) of the total sample (295) examined of the most commonly collected species, *Arrhenophanes perspicilla*. Also apparent from the La Selva survey is that the flight pattern of those species sampled is restricted to relatively close to the ground. No canopy light traps, which were operated the same number of nights and in the same vicinity as the ground traps (see "Material and Methods"), yielded Arrhenophanidae. Some evidence exists from the ALAS Microlepidoptera survey that suggests adult Arrhenophanidae are only active very late at night, perhaps in the early morning hours. Approximately 280 collection samples from blacklight sheets were made during approximately 1800–2300 hours between January 1993 and June 1996 which yielded few Arrhenophanidae. One likely explanation for these results could be that these moths do not fly until after 2300 hours.

Several unusual features have developed with regard to the mating biology of the Neotropical arrhenophanid genera (i.e., *Arrhenophanes*, *Cnissostages*, *Dysoptus*). Most Neotropical males are unusual in having a major portion of the vesica permanently extruded from the aedoeagus and typically directed at a sharp right angle from the apex (Figures 153, 230). Filamentous extensions of the vesica from the aedoeagus have been described and named in other moth families (Tuxen, 1956). Tillyard (1926) proposed the term penisfilum for what appears to be a normally extruded and retractable vesica. The "vitta," illustrated in several New Zealand Carposinidae by Philpott (1928), closely resembles the comparable but independently derived structure present in many Arrhenophanidae. The carposinid vitta also may be nonretractable, although this aspect was not discussed by Philpott and needs to be confirmed. I have applied the term "vitta" only to the external, nonretractable portion of the male vesica and have used both vitta and vesica interchangeably within the current study.

In *Arrhenophanes perspicilla*, the vitta can obtain a maximum length of 142 mm (Bradley, 1951), which is more than 24 times that of the aedoeagus and more than seven times the length of the entire body. Relative development of the vitta, however, varies considerably within the genera *Cnissostages* and *Dysoptus*. Considerable variation in the length of the vitta

often can be observed within species that normally have elongate vittae, probably the result of breakage following mating. A slender ribbon of chitin internally lines one side of the extruded portion of the vesica, thereby adding support as well as causing the vitta to coil. Because the coiled vitta cannot be withdrawn into the aedoeagus, typically it is retained in a special membranous invagination (apotheca, sensu Bradley, 1951) of the diaphragma located immediately dorsad of the aedoeagus (Figures 225, 228). Intact vittae are typically stored in one to as many as 16 coils inside the apotheca (when present), depending upon the species and the relative length of its vitta. Strong correlation in the relative development of the two structures normally occurs, with well-developed apothecae usually present in those species with long vittae. Occasionally (as in *Dysoptus spilacris*), little or no development of the apotheca occurs, with the greatly elongated vitta held at rest in a tight coil between the valvae. Males of *Arrhenophanes* and *Dysoptus* often are observed with a tangled mass of vitta protruding behind or around the abdomen (Figure 124). It is uncertain whether such instances were the result of failed mating attempts or whether the vitta was extruded immediately before death. As Bradley (1951) noted, because the vitta lacks any musculature, it would seem impossible to retract the structure into the apotheca once it had been extruded (by hydrostatic pressure). In the case of species such as *D. spilacris* (which does not possess a functional apotheca), simple recoiling of the vitta should be possible after fluid pressure has subsided. Examination of a series of conspecific males, as well as females that have mated, shows that the partially sclerotized vitta tends to be deciduous and is retained inside the female after mating. The frequency at which this occurs is unknown. Mated females of *Arrhenophanes perspicilla* typically possess broken segments of the male vitta along their correspondingly greatly lengthened ductus seminalis (Figure 252). Bradley (1951) first noted this phenomenon, but in his description he confused the bursa copulatrix with the ductus seminalis. It seems likely that mating occurs only once in those species with deciduous, elongate male vittae. Breakage of the vitta inside the female may ensure sperm precedence by effectively blocking the ductus seminalis from further mating attempts. The relatively short length of the ductus seminalis of the female in the Australian genus *Notiophanes* suggests that the male vitta may be only moderately extruded at most.

Parallel development of a greatly extended male vesica penetrating into a similarly lengthened female ductus seminalis has been observed in the sister family Psychidae (Davis, 1975). In the most-derived genera within both Arrhenophanidae and Psychidae, the corpus bursae—the customary storage receptacle for sperm—is apparently bypassed during copulation, with the sperm deposited nearer the junction of the common oviduct. Dissections of two mating pairs of the psychid *Thyridopteryx ephemeraeformis* (Haworth) revealed that the male vesica had been forced at least halfway through the greatly lengthened ductus seminalis of each female, thus effectively bypassing the bursa copulatrix. Vesicae of Psychidae are entirely membranous and always retracted into the aedoeagus after mating. In

those oiketicine Psychidae (e.g., *Oiketicus* and *Thyridopteryx*) that possess elongated vesicae, the enlarged base of the aedoeagus (Davis, 1964) functions in lieu of an apotheca for vesica storage.

An additional specialization of the male reproductive system has developed in *Dysoptus argus*. In this species an additional, more complex invagination has developed between the rectum and the rudimentary apotheca (Figure 225). This structure, of unknown function, is densely lined internally with spines. The sac opens caudally and subapically over a dorsally grooved, slender, midventral, thickened process from the diaphragma. No homolog of this structure exists within other Arrhenophanidae, nor is any known from other families of Lepidoptera. Spinose processes (chitinous tongue, sensu Dyar, 1927), sometimes arising from shallow, membranous invaginations of the diaphragma dorsad of the aedoeagus or from the transtilla (Corrales and Epstein, 1977), have been noted in some genera of Limacodidae. The function of these processes is likewise unknown.

Phylogeny of the Arrhenophanidae

Since the family's inception, authors have usually considered Arrhenophanidae to be closely associated, or even grouped (Robinson, 1988), with Psychidae. The development of a furcal bridge (Figures 38–40), formed by the fusion of the metafurca to the secondary furcal arms, constitutes an important synapomorphy found in the adult thorax of both families (Robinson, 1988; Davis and Robinson, 1998). Larvae of both families construct cases, although those of Psychidae tend to be more portable, with psychid larvae demonstrating certain specializations (e.g., prolegs directed more forward and thorax—particularly the pronotum and sterna—with greater fusion) for stronger mobility. The larvae of some Tineidae, as well as a few nontineoid families, also construct portable cases. Prior to pupation, arrhenophanid larvae invert their position inside the case with their head directed toward the posterior end. Similar behavior occurs in almost all Psychidae (Davis, 2000b) and in certain other families in which the larval case is suspended for pupation. Three possible autapomorphies serve to distinguish adult Arrhenophanidae: (1) the unusual prolongation of the caudal margin and sterigma of the eighth sternum, usually associated with the separation of the lamella postvaginalis from the eighth segment (Figures 236, 251, 254); (2) a pair of short, triangular apophyses from the anteriolateral corners of the male eighth sternum (Figures 42, 43, 45); and (3) the development in the males of a thickened, usually sclerotized anellus (Figures 129, 148, 149), typically fused to the transtilla and base of the valvae. The female ostium and lamella postvaginalis (when present) in Psychidae arise flush with the eighth segment; apophyses are lacking from the eighth sternum of most species, and the anellus is membranous.

Psychidae, which are primarily characterized by their more specialized larvae, may be derived from Arrhenophanidae.

What little is known of arrhenophanid larvae indicates that they are more generalized, with the prothoracic spiracle and prespiracular pinaculum separate from the pronotum, the prosterna less fused, and the labrum bearing only three pairs of epipharyngeal spines (Davis and Robinson, 1998; Davis, 2000a). The prothoracic spiracle of *Arrhenophanes* is oriented vertically (Figure 72), whereas that of Psychidae (Davis, 1987) lies more in a horizontal plane (with few exceptions). The basal outgroup for Psychidae + Arrhenophanidae is uncertain, although most likely it occurs within the Tineidae. In the following analysis, a hypothetical scardiine (Tineidae) ancestor has been used. The Scardiinae constitute a relatively well-defined subfamily of moderately large-bodied, fungivorous, tineid moths (Robinson, 1986, 1988; Robinson and Nielsen, 1993). Synapomorphies for the subfamily include the absence of a gnathos in the male genitalia and the presence of only two lateral setae on the prothoracic prespiracular (lateral) pinaculum. The absence of spinose setae from the apices of the tarsomeres of Arrhenophanidae may be a synapomorphy shared with Scardiinae, but this character has not been thoroughly analyzed within Tineidae (Davis, 1998a). The subfamily is mostly global in distribution but is most speciose in the Indo-Australian Region, with greatest generic diversity in the Neotropics (Davis and Robinson, 1998).

PHYLOGENETIC ANALYSIS

Cladistic analysis was performed on the five recognized genera of Arrhenophanidae, using the programs WINCLADA (Nixon, 1999a) and NONA (Goloboff, 1993). The family Psychidae (*Kearfottia*) was included in the analysis to show its close relationship with Arrhenophanidae. Possessing fully developed, functional wings, relatively well-developed (compared with most Psychidae) mouthparts (including haustellum, three-segmented maxillary, and labial palpi), *Kearfottia* represents one of the most basal lineages within Psychidae (Davis and Robinson, 1998). Plans now exist to analyze all groups of the Tineoidea to the subfamily level utilizing both morphological and molecular data. Even though larvae are unknown for four of the five arrhenophanid genera, three larval characters were included in the analysis. Searches for minimal-length cladograms, using the parsimony ratchet function in WINCLADA (Nixon, 1999b), resulted in four equally parsimonious trees of 43 steps (consistency index (ci)=0.76, retention index (ri)=0.66). Ratchet is a method that searches tree space very effectively by reducing the search effort spent on generating new starting points and retaining more information from existing results of tree searches. Analysis using the mult* function in NONA (Goloboff, 1993), which constructs a weighted Wagner tree with branch-swapping, yielded the same four trees. To show maximum basal differentiation between the families, the characters were optimized (fast) in WINCLADA, which likewise resulted in four topologies (Figure 2) of similar length, ci, and ri as the preceding. The tree preferred for this study (Figure

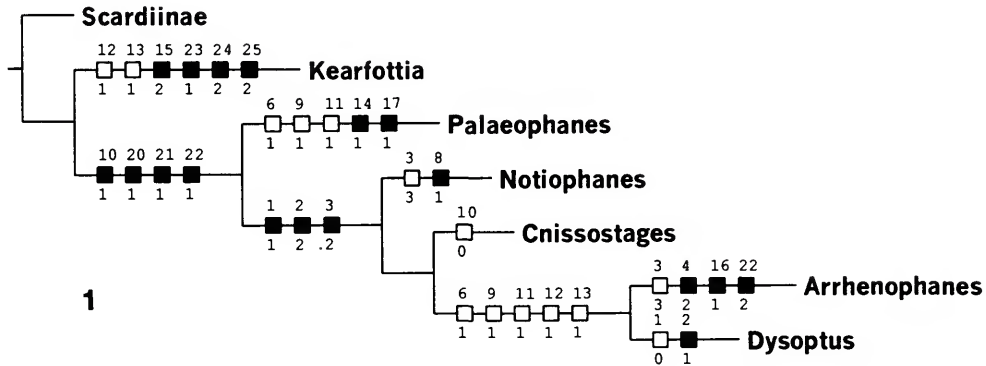

1

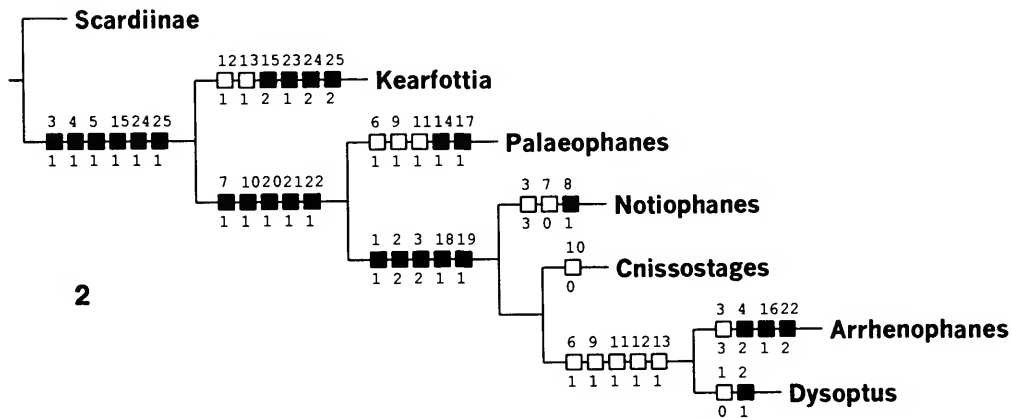

2

FIGURES 1, 2.—Preferred minimal-length cladograms of four trees derived from parsimony analysis of the character data presented in Table 2 (length=43 steps, consistency index=0.76, retention index=0.66). Squares indicate character-state transformations supporting nodes, with character number shown above and character state indicated below. Black squares represent unique, unreversed synapomorphies. 1, Preferred tree of four from analysis using ratchet (WINCLADA) and mult* (NONA); 2, preferred tree of four utilizing ratchet with fast optimization (WINCLADA).

1) groups the Old World genera basal to the Neotropical genera. Future collecting of both adults and larvae, particularly in southeast Asia, Australia, and Africa, could modify this tentative phylogeny considerably.

The Australian genus *Notiophanes* is represented by only a unique female. Missing male data for this genus undoubtedly has obscured resolution of the relationships between *Notiophanes* and *Crissostages*. Possessing all five radial veins in the forewing (Figures 32, 33), the two genera possess the most generalized venation within the family. Although *Crissostages* is not supported by any synapomorphy from the data in Table 1, it may be readily distinguished from *Notiophanes* by the different stalking of the radial veins and by differences in the female sterigma (Figures 237–241).

Characters Used in the Analysis

Head

1. Antenna. 0=not sexually dimorphic; 1=sexually dimorphic. Although the male of *Notiophanes* is unknown, the male antennae in this genus are believed to be less pectinated than those of the female, considering that the relative length of the female rami are among the longest within the family.

2. Female antenna. 0=filiform; 1=uniserrate; 2=bisectinate. The female antennae of *Arrhenophanes*, *Crissostages*, and probably *Notiophanes* are unusual in being more bisectinate than those of the males (Figures 12–15, 18, 19). I am aware of no other genus of Lepidoptera in which this type of dimorphism reversal occurs.

3. Haustellum. 0=>2.0×eye diameter; 1=1.0–0.5×eye

TABLE 2.—Character coding for the outgroup Scardiinae and the genera of Arrhenophanidae.

Taxa	Characters																								
	1	2	3	4	5	6	7	8	9	10	11	12	13	14	15	16	17	18	19	20	21	22	23	24	25
Scardiinae	0	0	0	0	0	0	0	0	0	0	0	0	0	0	0	0	0	0	0	0	0	0	0	0	0
<i>Arrhenophanes</i>	1	2	3	2	1	1	1	0	1	1	1	1	1	0	1	1	0	1	1	1	1	2	0	1	1
<i>Cnissostages</i>	1	2	2	1	1	0	1	0	0	0	0	0	0	1	0	0	1	1	1	1	1	?	?	?	
<i>Dysoptus</i>	0	1	2	1	1	1	1	0	1	1	1	1	1	0	1	0	0	1	1	1	1	?	?	?	
<i>Notiophanes</i>	1	2	3	1	1	0	0	1	0	1	0	0	0	?	?	?	?	?	?	1	1	1	?	?	?
<i>Palaeophanes</i>	0	0	1	1	1	1	0	1	1	1	0	0	1	1	0	1	0	0	1	1	1	?	?	?	
<i>Kearfottia</i>	0	0	1	1	1	0	0	0	0	0	1	1	0	2	0	0	0	0	0	0	0	1	2	2	

diameter; 2=0.4–0.1×eye diameter; 3=vestigial.

4. Maxillary palpus. 0=5-segmented; 1=3-segmented; 2=2-segmented.

5. Arms of metafurca. 0=free; 1=fused to secondary arms of metafurcasternum.

Forewing

6. Number of radial veins to margin. 0=5; 1=4. A full complement of five radial veins is preserved only in the genera *Notiophanes* and *Cnissostages*.

7. Radial veins 2 and 3. 0=separate; 1=stalked. The stalking of R2 and R3 is believed to be the common state within the family. Different interpretations with regard to naming the radial veins within this family have appeared in the literature. For my interpretation, see "Remarks" under the genus *Dysoptus* (page 28).

8. Radial veins 3 and 4. 0=separate; 1=stalked. The stalked condition of R3 and R4 is an apomorphy for *Notiophanes*.

9. Radial veins 4 and 5. 0=separate; 1=fused.

10. Radial veins 3, 4, 5. 0=all separate; 1=partial fusion. *Cnissostages* is the only arrhenophanid genus that retains the plesiomorphic condition.

11. Accessory cell. 0=present; 1=absent.

12. Medius within discal cell. 0=divided; 1=simple.

Hindwing

13. Medius within discal cell. 0=divided; 1=simple.

14. Vein 1A. 0=slightly curved; 1=sinuate. The strongly sinuate development of this vein is an autapomorphy of *Palaeophanes*.

Abdomen

15. Apophyses of male eighth sternite. 0=absent; 1=short (<0.5×length of S8), triangular (Figures 42, 43, 45); 2=slender, elongate (>0.5×length of S8). The development of stout, triangular apophyses on eighth segment in all male Arrhenophanidae possibly constitutes an autapomorphy for the family. Among the eight recognized subfamilies (Sauter and Hättenschwiler, 1991; Davis and Robinson, 1998) of the sister group Psychidae, sternal apophyses are known to occur only in the most derived group, Oiketinae, with the notable exception of the enigmatic genera *Eumasia* (Hättenschwiler, in litt.) and *Kearfottia*. Within Oiketinae the apophyses are typically

elongate (Davis, 1964), providing a strongly furcate outline to the eighth sternum. Extraordinary development of the apophyses within this subfamily may be a specialization that evolved in conjunction with various larviform reductions that have occurred in oiketidine females. These specializations have greatly modified mating behavior within the Oiketinae (Davis, 1964), necessitating a strengthening of male abdominal morphology, including the development of strong apophyses. Among all Psychidae, the short sternal apophyses of male *Eumasia parietariella* (Heydenreich) (Hättenschwiler, 1998) most resemble those of Arrhenophanidae. Because similar apophyses are lacking in the other basal groups of Psychidae, their similar development in one species of *Eumasia* is believed to represent a convergence. The eighth sternal apophyses of *Kearfottia* and all other *Eumasia* males examined possess long, slender apophyses more similar to those in Oiketinae, even though their females (with the exception of *E. brunella reducta* Hättenschwiler, 1998) are fully winged. Elongate, tubular apophyses also arise from the eighth sternum of a few scardiine (Tineidae) genera (Robinson, 1986).

16. Coremata. 0=present; 1=absent. Coremata (Figures 42, 43) are secondarily lost in the males of *Arrhenophanes* and in some species of *Dysoptus*.

Male Genitalia

17. Aedoeagus, ventral keel. 0=absent; 1=present. The development of a rather complex midventral ridge at the base of the aedoeagus is an autapomorphy of *Palaeophanes*.

18. Aedoeagus, vesica. 0=membranous and retractible; 1=partially sclerotized and non-retractible. Some species of *Cnissostages* and especially *Dysoptus* have the non-retractible vesica variably reduced.

19. Apotheca. 0=absent; 1=present. As in character 18, the apotheca may be secondarily reduced in *Cnissostages* and *Dysoptus*.

20. Anellus. 0=membranous; 1=thickened, usually sclerotized.

Female Genitalia

21. Sterigma. 0=flush to eighth sternum; 1=protruded. The caudal protrusion of the eighth sternum bearing the sterigma (including the ostium, Figures 236, 243, 245, 251, 253, 254) from that segment constitutes the principle autapomorphy

for the Arrhenophanidae. No such prolongation has developed within the sister family Psychidae (Davis, 1998b).

22. Lamella postvaginalis. 0=not separated from eighth segment; 1=present, separated, and extended; 2=present, separated, and flush with ostium. The sclerotized dorsal wall of the protruded eighth segment is considered homologous with the lamella postvaginalis (Figure 254). The normal condition of this lamella in Arrhenophanidae is to extend a short distance caudally beyond the ostium (Figures 235–238, 242–245). In a few species (e.g., in *Dysoptus argus*, Figure 251, and *Arrhenophanes*, Figures 253, 254), this wall has become secondarily reduced and flush with the dorsal margin of the ostium.

Larva

23. Epipharyngeal spines of labrum. 0=3; 1=4.

24. Prespiracular pinaculum/spiracle of prothorax. 0=separate; 1=including spiracle and completely fused to pronotum.

25. Prosternum. 0=membranous; 1=sclerotized, narrowly joined mesally (i.e., constricted; Figure 55); 2=mesal junction broad (not constricted).

ARRHENOPHANIDAE

Arrhenophanidae Walsingham, 1913:204.

TYPE GENUS.—*Arrhenophanes* Walsingham, 1913, by monotypy.

ADULT.—Small to moderately large moths, with forewings 4–33 mm in length.

Head (Figures 3–10): Vestiture generally rough, especially in *Palaeophanes*, but with scales of lower one-half of frons more densely packed and uniformly short, tri-quadridentate in other genera; scales of upper frons and vertex longer and more slender and partially directed down over frons. Ocelli absent. Eyes moderate to large, interocular index ~0.7–1.7; cornea naked. Antenna 0.3–0.6× length of forewing, 30–61-segmented; scape smooth to rough; pecten absent except for slender scale tuft in *Notiophanes*; flagellum filiform to serrate in male (male unknown in *Notiophanes*), serrate to bipectinate in female of all genera but filiform in both sexes of *Palaeophanes*; scales present only on dorsal one-half and arranged in multiple series per segment within irregular, longitudinal rows (Figure 20); 1 or 2 pedunculate setae projecting from anterior margin of each flagellomere, particularly in those species with filiform or serrate antennae; peduncles less pronounced and usually located at apices or anterior margins of rami on pectinate antennae. Pilifers and mandibles absent. Haustellum (Figures 4, 6, 8, 10) reduced to a short setose tube varying in length from ~2× length of first maxillary palpal segment in *Palaeophanes*, to essentially absent in *Arrhenophanes*. Maxillary palpi reduced to 2 or 3 short, rounded segments; when present, apical segment minute, one-fourth to one-third length of second. Labial palpi moderately long, upcurved, 3-segmented; lateral bristles absent.

Thorax: Metafurca (Figures 38–40) with furcal apophyses joined as a bridge to secondary arms. Forewings moderately

broad (Figures 29–37), W/L index 0.39–0.46; R variable, with either 4 or 5 branches to margin; R2 and R3 often stalked (separate in *Notiophanes* and sometimes in *Palaeophanes*); R4 and R5 separate in *Cnissostages*, stalked in *Notiophanes*, fused in *Palaeophanes*, *Dysoptus*, and *Arrhenophanes*; R5 terminating either on apex or termen; accessory and intercalary cells either present (*Palaeophanes*, *Notiophanes*, *Cnissostages*) or absent (*Dysoptus*, *Arrhenophanes*); 1A+2A with basal fork; a semi-transparent, hyaline spot sometimes developed in discal cell (especially in a few *Dysoptus* and in *Arrhenophanes*, Figures 119–123), with thin, mostly erect scales (Figures 47–49); male retinaculum consisting of a broad, triangular lobe arising from underside of costal membrane immediately anterior to, and curling over, base of Sc; female retinaculum poorly developed, primarily consisting of a dense concentration of scales from ventral caudal margin of base of subcostal vein. Hindwing W/L index 0.43–0.63; male frenulum a single stout seta; female with 4–14 frenular setae. Legs (Figure 46) with tibial spur pattern of 0-2-4; epiphysis present, length from one-third to two-thirds that of tibia; inner surface of epiphysis densely spinose. Tibia and tarsomeres without spines.

Abdomen: Paired sternal apodemes of A2 (Figures 41, 44) short, stout to slender, not parallel, tending to converge anteriorly; sternal rods present; S8 of male with anterolateral angles projecting anteriorly as short, triangular apodemes (Figures 42, 43, 45). Coremata usually present on S8 of male (absent in *Arrhenophanes* and in some *Dysoptus*), consisting of small, paired tufts of short, slender scales. Female with dense corethrogynae of long piliform scales encircling A7.

Male Genitalia: Uncus fused to tegumen, usually tapering to a slender, rounded apex, rarely bilobed. Vinculum usually Y-shaped, with a slender, elongate saccus, sometimes V-shaped. Gnathos absent. Transtilla well developed, firmly connecting bases of valvae. Anellus a thick membranous to sclerotized tube enclosing aedoeagus, often broadening at base to fuse with inner surfaces of valvae, and typically connected to vinculum by a slender jugum. Valvae elongate, usually with a prominent, strongly sclerotized lobe or process from apex of sacculus. Diaphragma usually invaginated in New World species (absent in Old World species) to form a large membranous sac (apotheca, Bradley, 1951) dorsad to anellus; apotheca absent in Old World species and in a few Neotropical species. Aedoeagus extremely slender and elongate, usually with a tenuous, permanently exerted, non-retractile, partially sclerotized vesica or vitta (in New World species), often exceeding length of aedoeagus; vitta normally coiled inside apotheca prior to mating, sometimes broken off inside ductus seminalis of female during copulation; vesica membranous and not permanently exerted in Old World species; aedoeagus with a basal, midventral, keel-like ridge in *Palaeophanes*.

Female Genitalia: Segments 8 and 9+10 forming a slender, elongate, telescoping ovipositor (Figures 235, 237) supported by 2 pairs of greatly lengthened apophyses, in addition to an elongate pair of pseudapophyses confined within the extended tenth segment. Caudal region of sternum 8 projecting

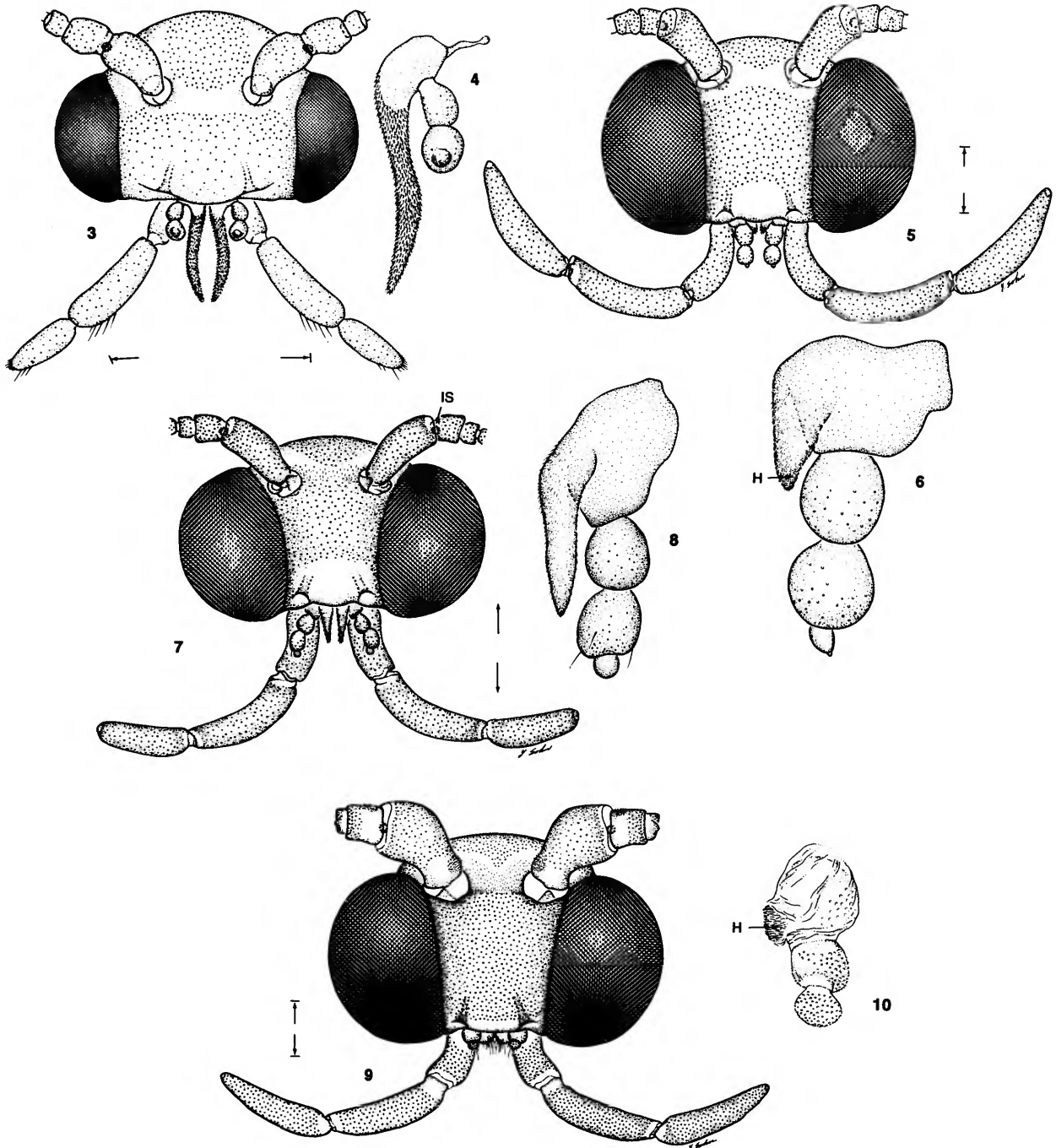

FIGURES 3-10.—Head morphology, anterior view. 3, *Palaeophanes lativalva* (0.5 mm); 4, maxilla (0.1 mm); 5, *Cnissostages oleagina* (0.5 mm); 6, maxilla (H=haustellum); 7, *Dysoptus argus* (0.5 mm; IS=intercalary sclerite); 8, maxilla; 9, *Arrhenophanes perspicilla* (0.5 mm); 10, maxilla (H=vestige of haustellum). (Scale lengths in parentheses.)



FIGURE 11.—Antenna. *Palaeophanes taiwanensis*: female (length 3.4 mm).

free of eighth segment up to two-thirds its length; ostium located at caudal margin of sternum 8; lamella postvaginalis typically projecting caudad of ostium, sometimes not so developed and flush with ostium. Ductus bursae elongate, usually broader and more thickened on caudal one-third (antrum). Ductus seminalis usually joining ductus bursae anterior to middle of latter, of variable length, usually extremely long in those species with male having greatly lengthened vesica. Corpus bursae moderately small, membranous, and without signa.

EGG.—Flat type (with micropylar axis parallel to substrate). Maximum length 0.8

7 mm, width 0.56 mm. All surfaces generally smooth except for reticular micropyle area composed of 25–35 irregular cells bounded by low ridges (Figures 51, 52).

LARVA.—Body up to 30 mm in length, whitish with yellowish brown head, pale brown to black notal plates and pinacula (Figures 53, 54). Frontoclypeus extending approximately two-thirds the distance to epicranial notch; ecdysial line terminating well before cranial notch. Six pairs of stemmata. Labrum with 3 pairs of epipharyngeal setae. Hypostoma narrowly joined at

midventer. Prespiracular plate containing spiracle completely separate from pronotal plate. Spiracles with a pronounced, raised peritreme, oval with the long axis oriented vertically; spiracular aperture with a dense, spinose filtering system. Coxae partially fused at midventer. Crochets arranged in a lateral penellipse; prolegs without peripheral spines; anal crochets in a semi-ellipse, opened caudally.

Larvae feed on bracken fungus (*Polyporus*) into which are constructed long, irregular, silk-lined tunnels; a tough, slightly flattened case is attached to the outer opening of the tunnel (Busck, 1912).

PUPA.—Head smooth, without frontal ridge. Wings relatively short, not surpassing A4. Pronotal spiracle elongate, transverse, with inner anterior margin minutely serrulate. First abdominal spiracle not exposed, located in membrane beneath hindwing sheaths. Dorsum of A3–A8 in male and A3–A7 in female, with a single anterior row of short spines; A3–A7 movable in male and A3–A6 in female. Spiracles functional on A1–A7; A8 with reduced, nonfunctional spiracles. Cremaster reduced to a pair of small tubercles on venter of A10.

Pupation occurs inside the larval case, with the adult emerging from a distal slit-like opening.

LIST OF SPECIES

- Palaeophanes* Davis
lativalva Davis
taiwanensis Davis
brevispina Davis
xoutha Davis
- Notiophanes* Davis and Edwards
fuscata Davis and Edwards
- Cnissostages* Zeller, 1863
oleagina Zeller, 1863
mastictor Bradley, 1951
tantiliza Bradley, 1951 [*lapis calami*]
osae Davis
- Dysoptus* Walsingham, 1914
Ecpathophanes Bradley, 1951 (new synonym)
fasciatus Davis
pseudargus Davis
prolatus Davis
sparsimaculatus Davis
denticulatus Davis
anachoreta (Bradley, 1951)
chiquitus (Busck, 1914)
tantalota Meyrick, 1914
probata Walsingham, 1914
bilobus Davis
pentalobus Davis
avittus Davis
asymmetrus Davis
acuminatus Davis
spilacris Davis
argus Davis
- Arrhenophanes* Walsingham, 1913
perspicilla (Stoll, 1790)
inca Meyrick, 1913 (new synonym)
volcanica Walsingham, 1913

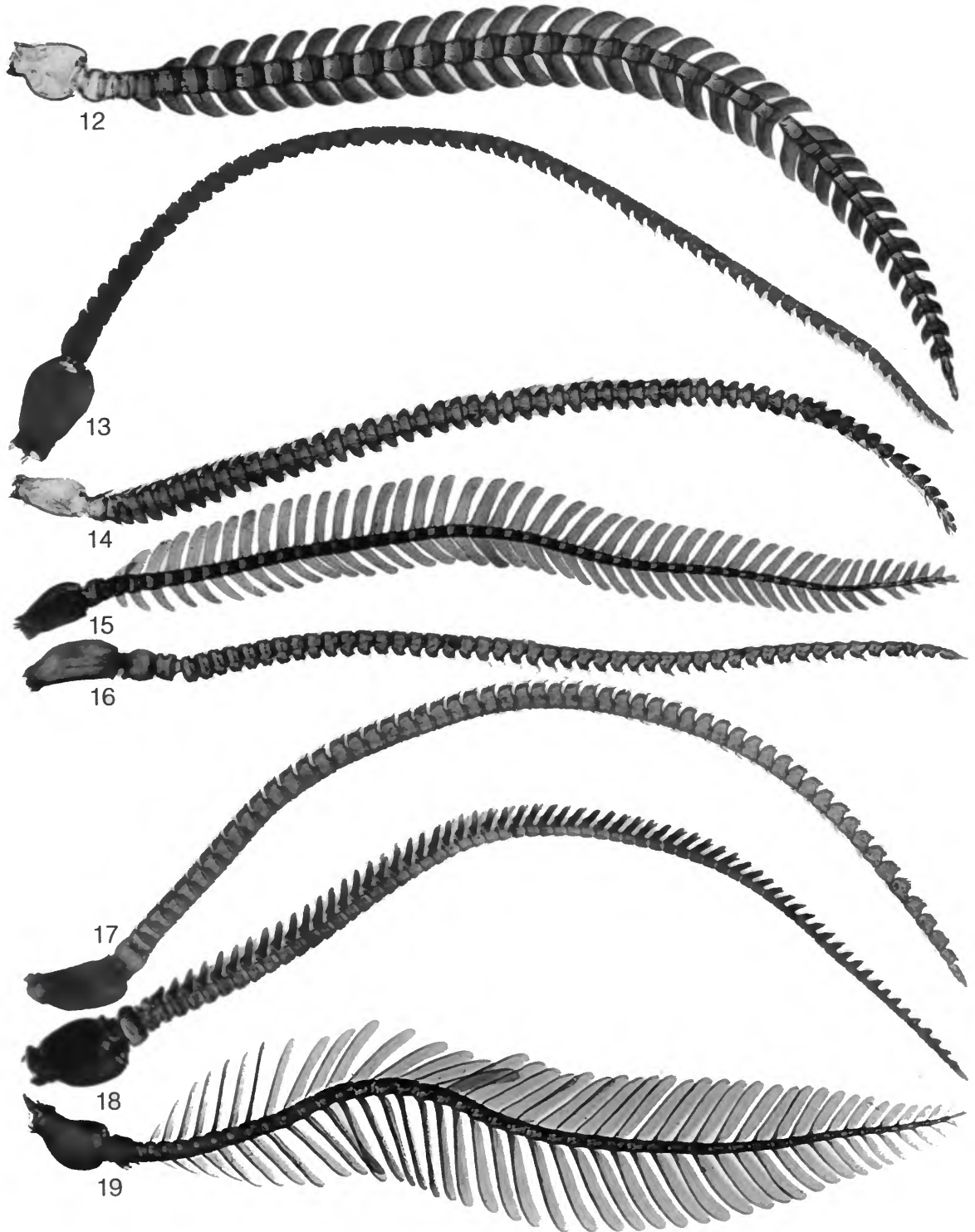

FIGURES 12-19.—Antennae. *Notiophanes fuscata*: 12, female (11.5 mm). *Cnissostages oleagina*: 13, male (7.5 mm); 14, female (10.5 mm). *Cnissostages masticator*: 15, female (13.5 mm). *Dysoptus argus*: 16, male (3.5 mm); 17, female (5.2 mm). *Arrhenophanes perspicilla*: 18, male (8.7 mm); 19, female (12.3 mm). (Antennal lengths in parentheses.)

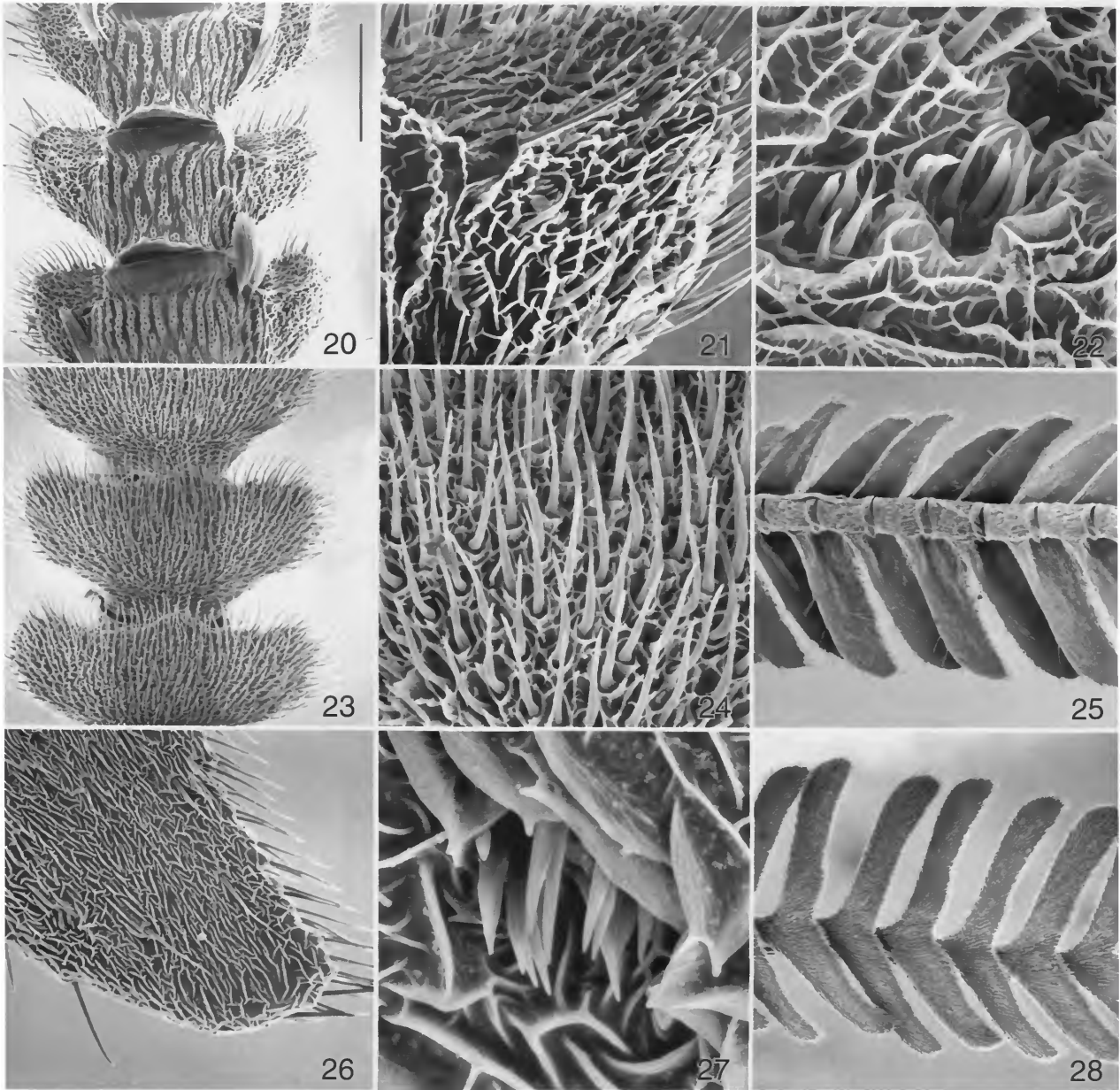

FIGURES 20–28.—Female antennal morphology. *Cnissostages oleagina*: 20, dorsal view (150 μ m); 21, detail of lateral ramus in Figure 20 (38 μ m); 22, detail of sensilla coeloconica in Figure 21 (15 μ m); 23, ventral view of Figure 20 (150 μ m); 24, detail of sensilla chaetica in Figure 23 (38 μ m). *Cnissostages mastictor*: 25, dorsal view (0.5 mm); 26, detail of lateral ramus in Figure 25 (75 μ m); 27, sensillum coeloconicum (10 μ m); 28, ventral view of Figure 25 (0.5 mm). (Scale lengths in parentheses.)

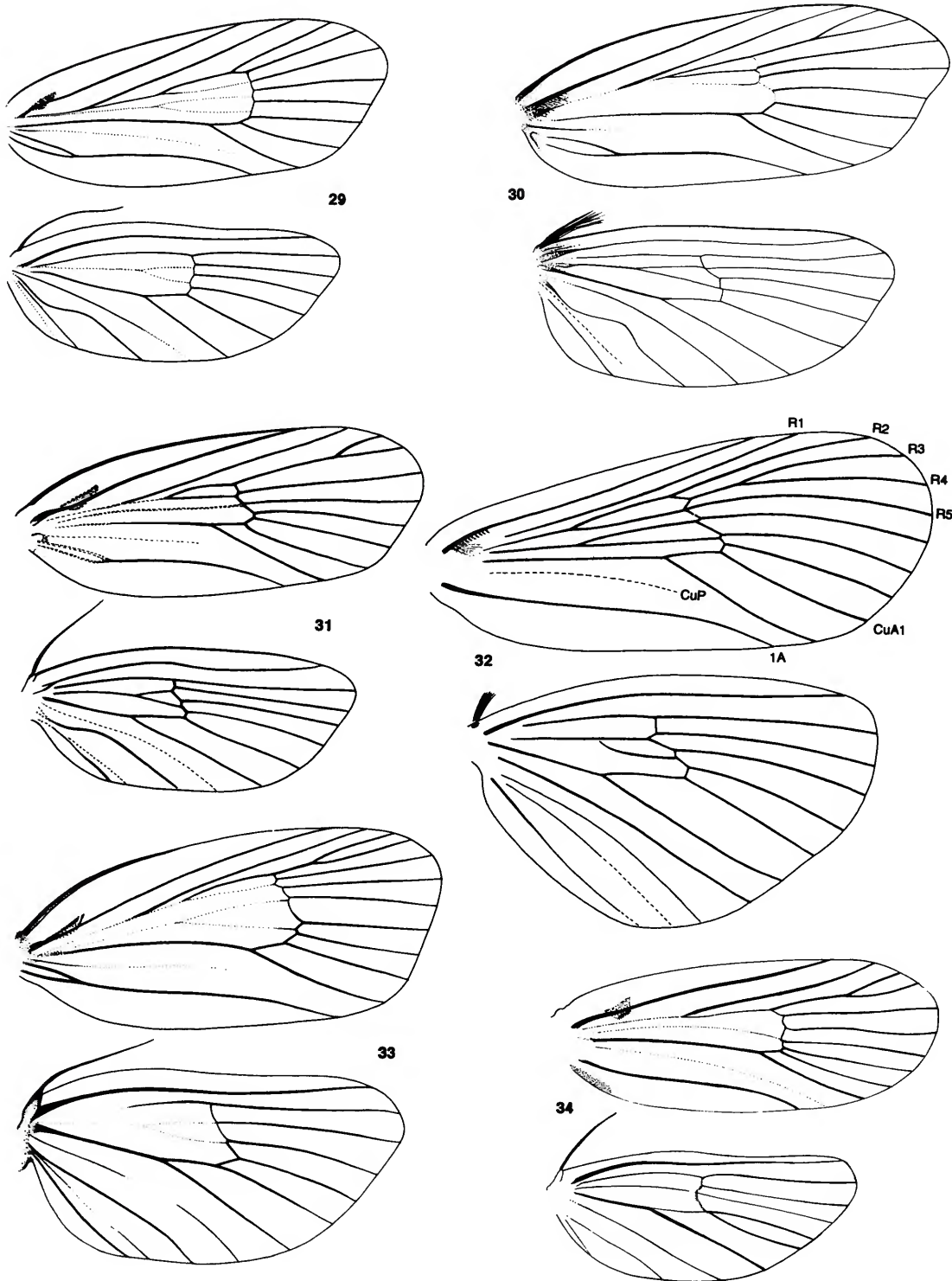

FIGURES 29–34.—Wing venation. *Palaeophanes lativalva*: 29, male. *Palaeophanes taiwanensis*: 30, female. *Palaeophanes xoutha*: 31, male. *Notiophanes fuscata*: 32, female. *Cnissostages oleagina*: 33, male. *Dysoptus fasciatus*: 34, male.

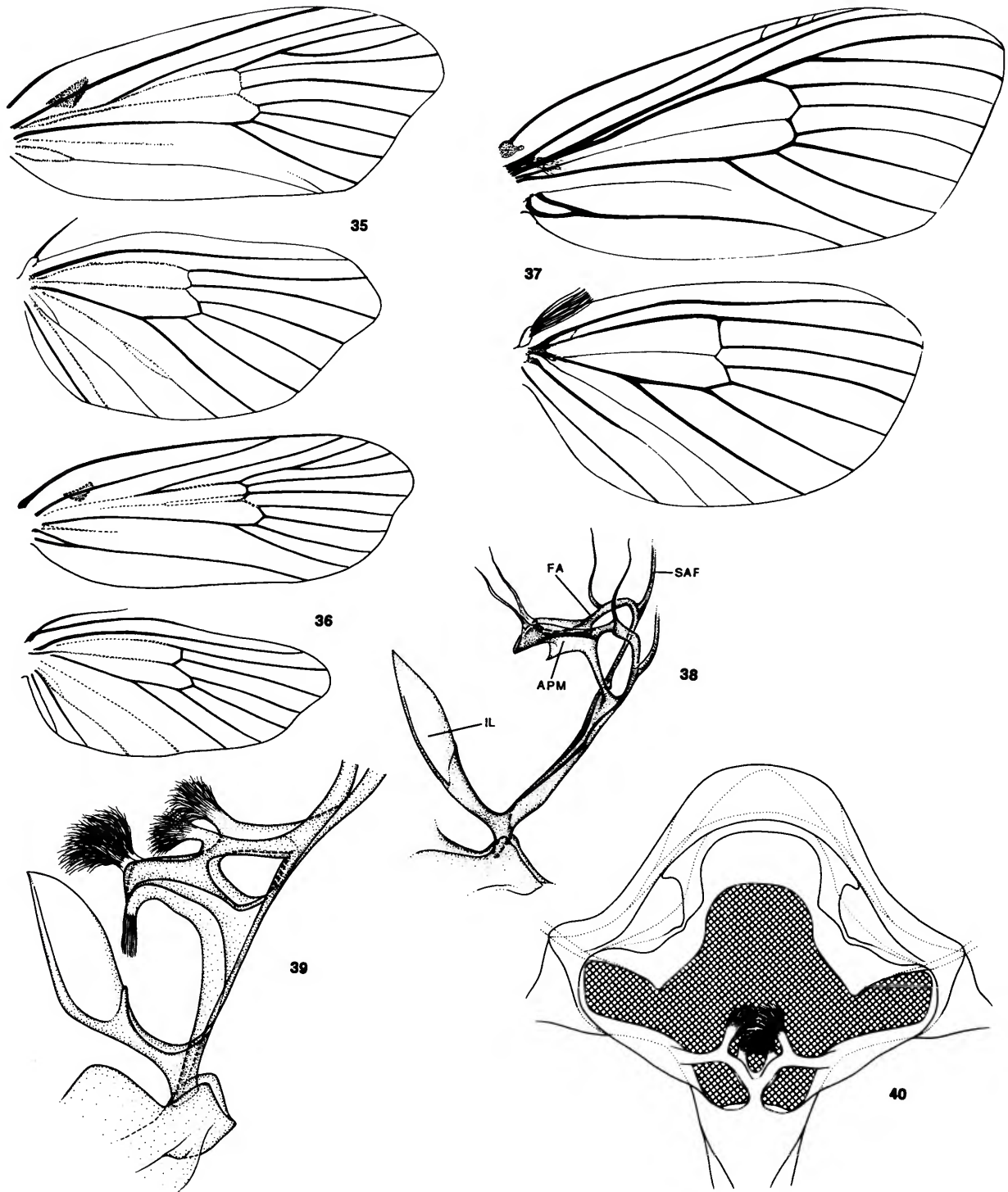

FIGURES 35-40.—Thoracic morphology. Wing venation: *Dysoptus anachoreta*: 35, male. *Dysoptus tataloia*: 36, male. *Arrhenophanes perspicilla*: 37, female. Metathoracic furcasternum: *Palaeophanes lativalva*: 38, lateral view (APM=anteromedial process of metafurcasternum; FA=furcal apophysis; IL=intercoxal lamella of basisternum; SAF=secondary arm of furcasternum). *Arrhenophanes perspicilla*: 39, lateral view; 40, caudal view of metathorax and Figure 39.

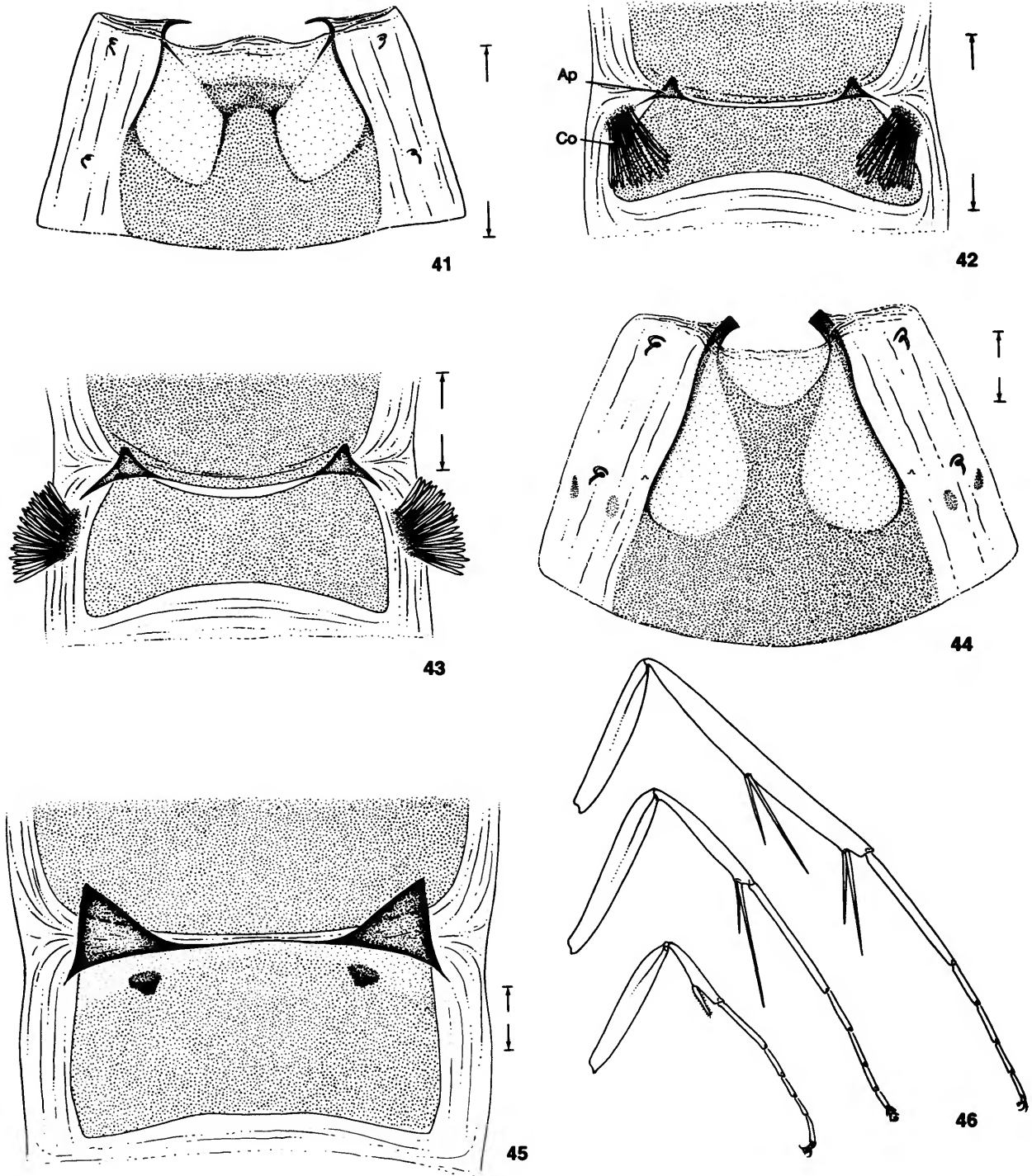

FIGURES 41-46.—Male abdominal morphology and legs. *Palaeophanes lativalva*: 41, second abdominal sternum (0.5 mm); 42, eighth abdominal sternum (0.5 mm; Ap=apodeme, Co=corematis). *Cnissostages oleagina*: 43, eighth abdominal sternum (0.5 mm). *Arrhenophanes perspicilla*: 44, second abdominal sternum (1.0 mm); 45, eighth abdominal sternum (1.0 mm). *Cnissostages oleagina*: 46, legs (1.0 mm). (Scale lengths in parentheses.)

Key to the Genera of Arrhenophanidae

1. Forewing with all five branches of radial vein reaching margin [Figures 32, 33] 2
Forewing with only four branches of radial vein reaching margin; R4 and R5 completely fused 3
2. Forewing with R2 and R3 stalked [Figure 33] *Cnissostages*
Forewing with R3 and R4 stalked [Figure 32] *Notiophanes*, new genus
3. Hindwing with vein 1A strongly sinuate at middle; M usually divided within cell; accessory cell present in forewing [Figures 29, 30] *Palaeophanes*, new genus
Hindwing with 1A only slightly curved; M not divided within cell; accessory cell absent in forewing [Figures 34, 35] 4
4. Forewing with vein R3 and usually R4+R5 terminating on costa before apex [Figures 34, 35]. Female antenna serrate *Dysoptus*
Forewing R3 and R4+R5 terminating on termen below apex [Figure 37]. Female antenna strongly bipectinate. *Arrhenophanes*

Palaeophanes, new genus

TYPE SPECIES.—*Palaeophanes taiwanensis*, new species.

MALE.—Length of forewing 4.7–5.7 mm.

Head (Figure 3): Vestiture of frons semi-erect, moderately rough; scales moderately broad, with bi- to quadridentate apices; scales of vertex longer, more rough, with low ridge of scales curling down toward frons between antennae; occiput with a pair of erect tufts; scales more slender, bidentate. Eye large, interocular index ~0.7. Antenna filiform, 0.30–0.45× length of forewing, 33–40-segmented; scape smooth; sensilla dense, ~1.0–1.5× diameter of flagellomere in length. Haustellum reduced (Figure 4) ~0.9× length of second segment of labial palpus. Maxillary palpus consisting of three short segments, ~0.35× length of haustellum. Labial palpus 3-segmented, upcurved, with a moderate ventral brush from segment II; bristles absent; ratio of segments from base: ~1.0:2.0:1.35.

Thorax: Generally smooth except for prominent median tuft from mesoscutellum. Forewing (Figure 29) moderately broad, W/L index 0.39, apex evenly rounded; radius 4-branched; R2 and R3 usually stalked one-half their length, usually separate in *P. lativalva*; R4 and R5 completely fused; accessory cell present; base of M usually faintly forked within cell. Hindwing almost equal to forewing in width, index 0.44; all veins arising separate from cell; 1A strongly sinuate. Frenulum consisting of a single large bristle. Foreleg with epiphysis well developed, approximately two-thirds length of foretibia.

Abdomen: Eighth segment (Figure 42) with a short, lateral pair of coremata.

Genitalia: Tegumen moderately slender and elongate, lightly sclerotized; caudal margin shallowly bilobed. Vinculum V- to T-shaped, with or without a distinct, rod-like saccus. Apotheca absent. Anellar tube firmly enclosing aedeagus, articulating with vinculum and inner bases of valvae by means of slender juxta. Valva moderately slender to broad, divided into a large, setose dorsal lobe (cucullus) and slender to broad ventral lobe (sacculus); apex of ventral lobe with 1 or 2 prominent, spinose processes. Aedeagus moderately to strongly curved, with

ventral basal keel and sometimes with slightly more caudal dorsal keel; apex of aedeagus asymmetrical and occasionally partially spiraled; vesica not permanently extruded.

FEMALE.—Length of forewing 9 mm. Similar to male except antenna relatively shorter, ~0.35× length of forewing, approximately 40-segmented. Frenulum consisting of a large cluster of 8–10 smaller bristles.

Abdomen: Seventh segment short, with corethrogynae consisting of dense encirclement of elongate hairs; seventh sternum extremely short, caudal margin curved toward median protrusion; caudal margin of tergum concave.

Genitalia: Posterior apophyses elongate, 1.4× length of anterior apophyses. Much of eighth segment, including lamella postvaginalis, densely covered with minute spines. Lamella antevaginalis slightly convex. Antrum elongate, maximum width ~0.4× its length, gradually narrowing anteriorly; junction of ductus seminalis near anterior one-third of ductus bursae. Corpus bursae membranous; signum absent.

ETYMOLOGY.—The generic name is derived from the Greek *palaios* (ancient, old), joined to the generic stem *phanes* (from *phaino*: shine, appear), in reference both to its Old World distribution as well as its current basal position within the family. The generic name is masculine.

REMARKS.—When I first referred to this genus in an earlier publication (Davis, 1991), I stated that all major veins in the forewing arose separately. This has since been found to vary, with most species examined having R2 and R3 stalked (Figure 30). In *P. lativalva* (Figure 29), R2 and R3 usually are separate but were connate in one example.

The genus is defined by at least four synapomorphies: (1) vein A1 sinuate in forewing; (2) aedeagus with basal, midventral keel; (3) orifice of aedeagus asymmetrical; and (4) saccular lobe of male valva well developed and terminating in one or two sharp spines. In addition, the male vesica is membranous and retractable, presumably the plesiomorphic state, contrasted to the permanently everted, non-retractable condition in most Neotropical species. The haustellum of *Palaeophanes*, although reduced compared with most moth families, is the most

developed of any Arrhenophanidae.

Assignment of *Palaeophanes* to the Arrhenophanidae is based primarily upon female genital morphology, the development and separation of the lamella postvaginalis (Figures 235, 236) in particular, and similar seventh abdominal apophyses (Figures 42, 43, 45). Family kinship also is suggested by the similar wing pattern of the Taiwanese species with several spe-

cies of Neotropical *Dysoptus*. The fusion of the furcal apophyses with the secondary arms of the metafurcasternum is shared with the Psychidae.

Also examined in the collections of the BMNH is a unique example of an undescribed species in poor condition from Brunei, which should not be named until better material becomes available.

Key to the Species of *Palaeophanes*

1. Base of aedeagus with caudally projecting ventral keel; dorsal lobe absent [Figures 128, 132, 136] 2
Base of aedeagus with an anteriorly projecting ventral keel and a caudally directed dorsal lobe [Figures 140, 145] 4
2. Male genitalia with broad, V-shaped vinculum [Figures 129, 133]; ventral lobe of valva slender, tapering, with two large apical spines 3
Vinculum a narrow ring ventrally, T-shaped [Figure 125]; valva with broad, truncate saccular lobe bearing a single apical spine [Figure 127] ... *P. lativalva*, new species
3. Forewings predominantly dark fuscous [Figure 88]. Distribution Taiwan
..... *P. taiwanensis*, new species
Forewings paler, predominantly gray/white [Figure 90]. Distribution Sabah, Malaysia *P. sp.*
4. Male valva with a single elongate spine from apex of otherwise truncate ventral lobe [Figure 144] *P. xoutha*, new species
Male valva with a minute spine at base of elongate apical spine; ventral lobe tapering to apex [Figure 139] *P. brevispina*, new species

Palaeophanes lativalva, new species

FIGURES 3, 4, 29, 38, 41, 42, 87, 125–128; MAP 1

MALE (Figure 87).—Forewing length 4.7–5.0 mm.

Head: Vestiture dark brownish fuscous, slightly paler and more grayish on lower frons. Antenna ~0.4× length of forewing, 33- or 34-segmented; scape, pedicel, and first 1 or 2 segments of flagellum dark brownish fuscous; next 12–14 flagellomeres with pale cream scales dorsally; remainder of flagellum naked, dark brown. Labial palpus predominantly dark brownish fuscous, paler and more grayish mesally.

Thorax (Figure 38): Dark brownish fuscous dorsally, shiny gray ventrally. Forewing dark brownish fuscous, lightly marked with small, pale cream spots; pattern differs from that of *P. taiwanensis* in having basal costal spot smaller, more slender, and situated more distad toward middle of costa; apical spot also smaller and more slender, with a narrow band of dark scales separating pale cream of fringe; terminal spot below apex continuous into fringe; a small spot along basal one-third of hind margin and 3 or 4 smaller spots scattered across middle of wing; fringe same color as wing except where interrupted by pale cream as described. Forelegs mostly dark brownish fuscous, with extreme apex of tibia and tarsomeres 1–3 pale cream; apex of 3 tipped with brownish fuscous; apex of 5 sometimes pale cream; mid- and hindlegs brownish fuscous

dorsally, paler, gray to pale cream ventrally; most tarsomeres narrowly ringed with pale cream.

Abdomen (Figures 41, 42): Dark brownish fuscous dorsally, dark shiny gray ventrally. Sternum 8 with a bilateral pair of short coremata present.

Genitalia (Figures 125–128): Vinculum-saccus T-shaped; saccus moderately short, ~0.2× length of valva. Anellus membranous, connected to vinculum by an elongate, laterally compressed, sinuate juxta. Valva extremely broad (Figure 127), width ~0.55× length; dorsal (cucular) lobe very slender, digitate, separated approximately one-third length of valva; ventral (saccular) lobe very broad, with a slender, curved spinose process near dorsal lobe; ventral apex extending total length of valva. Aedeagus an elongate, dorsally arched, acute rod (Figure 128); basal, ventral keel elongate, projecting caudally approximately twice its linear width; apex with asymmetrical orifice, the right margin excavated.

FEMALE.—Unknown.

HOLOTYPE (Figure 87).—TAIWAN: CHAIYI-HSIEN: Fennchihwu, 1450 m, ♂, 2–4 Jul 1985, J.[B.] Heppner & H. Wang (NMT, on indefinite loan to FSCA).

PARATYPES.—TAIWAN: CHAIYI-HSIEN: Fennchihwu, 1400 m: 2♂, 17 Jul 1984, Y. Arita, slide DRD 3757 (FSCA, USNM). Fennchihwu, 1450 m: 3♂, 2–4 Jul 1985, J.[B.] Heppner & H. Wang, slides DRD 3759, JBH 2019 (FSCA, NMT).

FLIGHT PERIOD.—July.

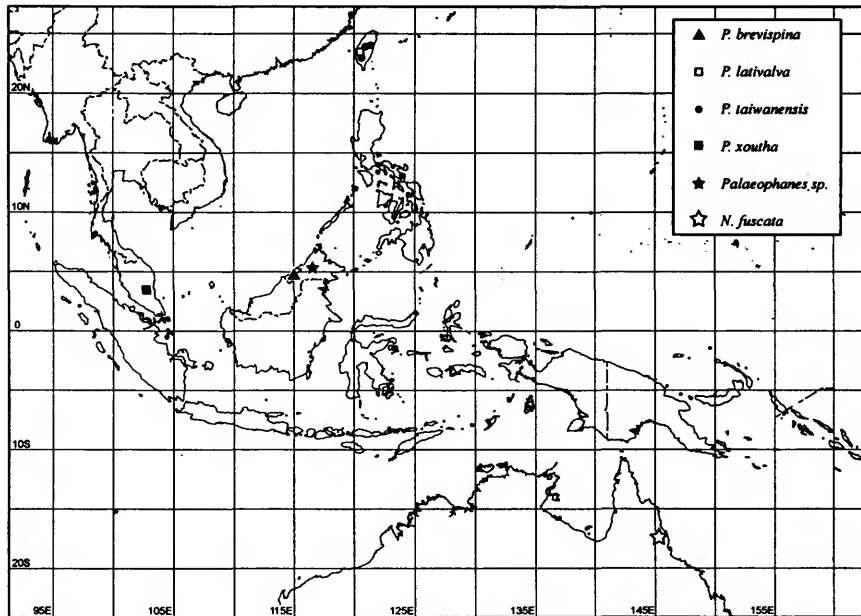

MAP 1.—Distribution of *Notiophanes fuscata*, *Palaeophanes brevispina*, *P. lativalva*, *P. taiwanensis*, *P. xoutha*, and *P. sp.*

DISTRIBUTION (Map 1).—Known only from the type locality, which is situated in a wet forested area in the central mountain range of Taiwan, at an elevation of approximately 1400 m.

ETYMOLOGY.—The specific name is derived from the Latin *latus* (broad) and *valva* (leaf of a folding door, valve), in reference to the principal apomorphy of this species—the extremely broad valvae of the male genitalia.

REMARKS.—Although superficially resembling *P. taiwanensis*, the only other arrhenophanid known from Taiwan, *P. lativalva*, can be distinguished by the more reduced apical and basal costal spots of the forewing (Figure 87). The male valvae of *P. lativalva* are most similar in general morphology to those of *P. xoutha*. The lower margin of the saccular lobe in the valva of *P. lativalva* is the most expanded of any member of the family. Likewise, the aedeagus is the most curved of any species.

Palaeophanes taiwanensis, new species

FIGURES 11, 30, 88, 89, 129–132, 235, 236; MAP 1

MALE (Figure 88).—Forewing length 4.8–5.8 mm.

Head: Vestiture of frons cream to off-white, lightly suffused with yellowish brown dorsally; vertex pale yellowish brown. Antenna approximately one-third length of fore-wing, 37–40-segmented; scape mostly yellowish brown, with suffusion of dark brownish fuscous dorsally; flagellum golden yellowish brown with dark brownish fuscous annulation dorsally on basal one-fourth. Labial palpus cream to off-white, with grayish brown suffusion dorsally on segments I and II.

Thorax: Dark brownish fuscous dorsally; spatulate scales of mesonotal tuft with pale gray bases; pale brown to yellowish brown ventrally. Forewing dark brownish fuscous, marked with variably sized white to cream spots, the largest of which curves slightly from basal one-fourth of costa, a much smaller costal spot at distal one-third, a spot of similar size at basal one-third near hind margin, and 3–5 minute spots consisting of only a few scales scattered on outer one-third of wing, with one often present at basal one-fourth; termen with an elongate spot above apex and one below apex that extend into fringe; fringe fuscous except where interrupted by whitish spots. Hindwing uniformly dark brownish fuscous. Legs relatively uniform in color, usually fuscous dorsally, pale gray to yellowish brown ventrally and on tarsi.

Abdomen: Dark fuscous dorsally, cream to yellowish brown ventrally and around genitalia. Sternum 8 with a short, bilateral tuft of coremata.

Genitalia (Figures 129–132): Vinculum-saccus broadly V-shaped, $\sim 0.55 \times$ length of valva. Anellus a moderately elongate, membranous tube enclosing approximately one-third of aedeagus. Juxta a moderately broad, triangular band around base of anellus, and loosely attached to inner surface of vinculum. Valva similar to *Palaeophanes* sp. from Sabah, but with valva less deeply divided (approximately one-third its length) and with costal margin smooth, slightly convex; ventral, saccular lobe terminating in two large spines. Aedeagus slightly exceeding length of valva, moderately sinuate, with small, subap-

ical, dorsal uncinat spine; small, stout, ventral, keel-like process from base.

FEMALE (Figures 30, 89).—Forewing length 9.0 mm. Color pattern generally similar to male. Antenna 40-segmented.

Abdomen: Similar to male, except with corethrogyne encircling A7, cream ventrally, pale yellowish brown dorsally.

Genitalia (Figures 235, 236): Lamella antevaginalis with caudal margin slightly irregular but symmetrical, with a low, truncate, median lobe. Caudal margin of lamella postvaginalis acuminate. Antrum with caudal end broadly triangular, tapering to an elongate tube more than two-thirds length of entire ductus bursae. Corpus bursae enlarged, with large duct from middle.

HOLOTYPE.—TAIWAN: KAOHSIUNG: Liukuei Forest Station, 750 m, ♂, 29 Apr–3 May, 1983, J.[B.] Heppner & H. Wang (NMT, on indefinite loan to FSCA).

PARATYPES.—TAIWAN: NAN TOW: Lien-Hua-Chih Forest Station, 12 km S Puli, 700 m: 1 ♀, 7–12 Sep 1983, J.B. Heppner, slide DRD 4005 (FSCA). Lu-Shan, ~30 km E Wu-Hsi, 1000 m: 1 ♀, 27–30 May 1980, D.R. Davis, slide USNM 30437 (USNM). KAOHSIUNG: Liukuei Forest Station, 750 m: 1 ♂, 29 Apr–3 May 1989, J.[B.] Heppner & H. Wang, slide DRD 3758 (NMT).

DISTRIBUTION (Map 1).—This species occurs in wet forests within the central mountain range of Taiwan at elevations of 700–1000 m.

ETYMOLOGY.—The specific name denotes the country of origin of the type material.

REMARKS.—Although superficially resembling *P. lativalva*, the other Taiwanese member of this family, the two species differ greatly in male genital morphology, particularly with respect to the width of their valvae and the curvature of their aedeagi. The male genitalia of *P. taiwanensis* is most similar to that of an unnamed species from Sabah, Malaysia (Figure 135), particularly with respect to the broadly triangular vinculum and morphology of the valva.

Palaeophanes sp.

FIGURES 90, 133–136; MAP 1

MALE (Figure 90).—Length of forewing 6.5 mm.

Head: Frons yellowish brown with suffusion of fuscous laterally along inner rim of eye; vertex predominantly fuscous, irrorated with white; occipital tufts mostly white with mesal suffusion of fuscous. Antenna ~0.3 × length of forewing; scape white to cream, with suffusion of fuscous dorsally at base; pedicel dark fuscous dorsally; flagellum with basal one-fifth fuscous, distal four-fifths cream. Maxillary palpus apparently 3-segmented, mostly cream, with fuscous suffusion at base; apical segment minute, entirely fuscous. Labial palpus [broken] fuscous laterally, white to yellowish brown mesally.

Thorax: Dorsum fuscous irrorated with yellowish brown to white scales; mesoscutellum bearing dense tuft of white to yellowish brown piliform scales with broad fuscous apices; venter

cream. Forewing predominantly white to cream, irregularly irrorated with yellowish brown to fuscous scales; a small, raised patch of fuscous scales particularly at apex of discal cell; fringe fuscous, interrupted by at least two patches of white along termen. Hindwing white to cream, with a thin golden brown margin. Legs predominantly cream to yellowish brown, with slight suffusion of brown and fuscous on foretibia and tarsus.

Abdomen: Light brown dorsally, cream ventrally.

Genitalia (Figures 133–136): Vinculum broadly V-shaped. Valva deeply divided approximately one-half its length; saccular lobe tapering to apex terminating in two large, curved spines of almost equal length. Aedeagus with a prominent, dorsal, recurved spine at distal one-fourth; basal ventral keel directed caudally.

FEMALE.—Unknown.

MATERIAL EXAMINED.—MALAYSIA: SABAH: Gunong Monkobo, 975 m, 5.4°N, 116.56°E: 1 ♂, 7–13 Aug 1987, K.R. Tuck, BM slide 27916 (BMNH).

DISTRIBUTION (Map 1).—Known only from the type locality.

REMARKS.—Because of the poor condition of the single known specimen, this species has not been named. On the basis of male genital morphology, it appears most allied to *P. taiwanensis*. Both possess broadly triangular vincula, valvae with paired saccular spines, and similar aedeagi without a basal, dorsal keel (Figure 136).

Palaeophanes brevispina, new species

FIGURES 91, 137–141; MAP 1

MALE (Figure 91).—Length of forewing 6.0 mm.

Head: Vestiture pale yellowish brown to cream, with slight suffusion of fuscous on frons. Antenna approximately one-third length of forewing; pale yellowish brown dorsally with light suffusion of fuscous; ventral sensilla 1.2–1.5 × diameter of flagellomere. Labial palpus pale yellowish brown, strongly suffused with fuscous along upper lateral surfaces of segments I and II.

Thorax: Mesonotum (partially descaled) pale yellowish brown with suffusion of fuscous along costal edge of tegula; venter pale yellowish brown. Forewing (rubbed) predominantly pale golden, yellowish brown, strongly suffused with fuscous near base of costa and on distal one-fourth of wing, and with cream spots along costal margin as follows: a large triangular spot at basal one-fourth, a small triangular spot on distal one-third, a smaller spot at apex, and an elongate spot along termen where it continues into fringe; fringe mostly cream with fuscous interruptions at apex and tornus. Hindwings uniformly pale gray. Legs pale yellowish brown to cream.

Abdomen: Pale brown dorsally; pale yellowish brown, almost white ventrally.

Genitalia (Figures 137–141): Saccus well defined, moderately long, ~0.45 × length of entire vinculum. Valva deeply divided; saccular lobe with an elongate, slightly curved apical process and a much shorter, subapical process. Aedeagus with

apical one-eighth partially curled along longitudinal axis; base with short dorsal lobe; ventral keel with lateral flanges (Figure 140).

FEMALE.—Unknown.

HOLOTYPE (Figure 91).—BRUNEI: Ulu Temburong, 300 m, ♂, 26–30 Apr 1989, M. Allen and K. Tuck, BM slide 27912 (BMNH).

DISTRIBUTION (Map 1).—Known only from the type locality.

ETYMOLOGY.—The specific epithet is derived from the Latin *brevi* (short) and *spina* (thorn), in reference to the diagnostic short, subapical spine on the male valva.

REMARKS.—The male genitalia of this species are unique in having a minute, subapical spine on the sacculus lobe, immediately below a long, apical spine (Figure 139). Although the forewings are slightly denuded in the only specimen examined, the general color pattern of *P. brevispina* appears similar to *P. xoutha* (Figure 92). It shares two derived specializations of the male aedeagus with *P. xoutha*: a basal, caudally directed dorsal lobe and a highly modified, partially spiraled, asymmetrical apex. The apex is less modified (not spiraled), and the dorsal lobe is absent in the other three species of *Palaeophanes*.

Palaeophanes xoutha, new species

FIGURES 31, 92, 142–148; MAP 1

MALE (Figure 92).—Length of forewing 6.0 mm.

Head: Frons pale brown to cream, vertex pale brown. Antenna one-third length of forewing; scape white to cream ventrally, pale brown dorsally with few scattered, dark brown scales; fragellum pale brown dorsally; sensilla approximately equal to diameter of flagellomeres in length. Labial palpus pale brown ventrally, darker brown dorsally.

Thorax (Figure 31): Mesonotum yellowish brown, smooth except for small, loose tuft of long, slender scales with broad, dark apices arising posteriorly from scutellum. Venter pale yellowish brown. Forewing predominantly yellowish brown variously marked with white as follows: a moderately large, triangular spot at basal one-third of costa and a smaller triangular spot at distal one-third; three broken bands of white spots bordered by brownish fuscous at basal one-third of wing, near apex of discal cell, and near termen, the subterminal band being the largest; terminal fringe with basal scale row yellowish brown suffused with pale fuscous; outer row mostly white, interrupted by fuscous scales at apex, middle, and tornal areas. Hindwing pale gray; fringe pale yellowish brown. Legs yellowish brown to pale yellowish brown.

Abdomen: Light brown dorsally, pale yellowish brown ventrally. Eighth segment with small bilateral pair of coremata.

Genitalia (Figures 142–148): Saccus short, approximately one-fourth total length of vinculum. Valva deeply divided; sacculus lobe with a single, long, slender process. Aedeagus with apical one-sixth partially curled along axis as in *P. brevispina* (Figure 140) but more abruptly set off from basal shaft.

FEMALE.—Unknown.

HOLOTYPE (Figure 92).—MALAYSIA: Western Pahang, Genting Tea Estate, ♂, 29 Nov 1994, G.S. Robinson, MV light, 27912 (BMNH).

PARATYPE.—Same locality as holotype, except: 1 ♂, 2000 ft [610 m], 1–8 Nov 1991, K. Tuck, M.V. light by stream, BM slides 27911, 29490 (BMNH).

DISTRIBUTION (MAP 1).—Known only from the type locality.

ETYMOLOGY.—The specific name is derived from the Greek *xouthos* (yellowish brown), in reference to the predominantly yellowish brown color of the adult.

REMARKS.—As discussed in the preceding species, this species and *P. brevispina* are closely allied, as shown by two synapomorphies of the male aedeagus—the dorsal lobe at the base of the aedeagus and the partially spiraled apex. Their color patterns also are probably similar, although this is only faintly indicated in the partially denuded forewings of the holotype of *P. brevispina*.

Notiophanes Davis and Edwards, new genus

TYPE SPECIES.—*Notiophanes fuscata* Davis and Edwards.

MALE.—Unknown.

FEMALE.—Length of forewing 27.0 mm.

Head: Lower frons covered with densely packed, semi-erect, short, broad, 4- or 5-dentate scales; scales of upper frons less dense, more raised, gradually becoming more slender and less dentate toward antennae; scales of vertex more erect, directed forward, partially overlapping scales of upper frons, elongate and moderately slender, with tridentate apices. Eye large, interocular index 1.03. Antenna (Figure 12) one-third length of forewing, 41-segmented; scape entirely scaled, with a slender, elongate scale tuft from basal anterior margin; flagellum bipectinate from third flagellomere (fifth antennal segment) to penultimate segment; rami short, maximum length approximately twice the diameter of main shaft; dorsal surface of main shaft of flagellum with 3 or 4 scattered rows per segment of short, moderately broad scales to apex; remainder of flagellum including rami naked except for minute sensilla. Maxillary palpus short, not exceeding length of basal labial palpal segment, apparently 3-segmented; Haustellum not visible. Labial palpus elongate, length almost 4× diameter of eye, subcorrect, only slightly upcurved; segment II more than twice length of III, with rough scaling ventrally; apical segment entirely smooth.

Thorax: Forewing (Figure 32) moderately broad, W/L index 0.42; apex rounded; radius 5-branched; R3 and R4 stalked approximately one-third length of R3; accessory cell present, chorda well developed, extending approximately one-half length of discal cell; base of M strongly furcate within cell, slightly exceeding accessory cell in length. Hindwing broad, W/L index 0.63; frenulum consisting of a cluster of approximately 10 fine bristles, arising in a compact, cylindrical bundle; base of M furcate within cell; 1A slightly curved, not sinu-

ate. Foreleg with epiphysis well developed, $\sim 0.6 \times$ length of tibia.

Abdomen: Corethrogyne consisting of two layers of long piliform scales—a relatively sparse layer of straight scales overlaying a circular mat of finer, much denser, crimped scales.

Genitalia: Posterior apophyses $1.4 \times$ length of anterior pair. Eighth sternum with midventer slightly produced into a low, longitudinal ridge; caudal margin of lamella antevaginalis relatively broad, subtruncate, slightly sinuate (Figure 237); lamella postvaginalis projecting free from underlying segment almost one-third length of eighth sternum (Figure 238); caudal margin mostly rounded but tapered, with a minute apical notch. Antrum slightly less than one-third total length of ductus bursae, broad at ostium, then gradually tapering anteriorly to form slender ductus to enlarged, membranous corpus bursae; corpus bursae $\sim 0.6 \times$ length of anterior apophyses. Ductus seminalis of large diameter relatively short, length to junction of common oviduct approximately one-fourth length of anterior apophyses, joining ductus bursae at anterior one-fifth of latter.

ETYMOLOGY.—The generic name is derived from the Greek *notios* (southern), added to the generic stem *phanes* (from *phaino*: shine, appear), in reference to its Australian distribution. It is feminine in gender.

REMARKS.—Because only one specimen was available for study, examination of some anatomical features must await the discovery of additional material for confirmation. This applies particularly to mouthpart and thoracic morphology, male genitalia, as well as wing venation. For example, the basal separation of veins 1A and 2A in the forewing actually could not be observed in the intact wing. It has been drawn as divided to agree with the condition typical throughout the family.

Notiophanes fuscata Davis and Edwards, new species

FIGURES 12, 32, 93, 237, 238; MAP 1

FEMALE (Figure 93).—Forewing length 27.0 mm.

Head: Vestiture mostly yellowish brown on lower frons, becoming abruptly dark fuscous on upper frons to antennae; a small patch of grayish white scales between antennal bases; scales of vertex mostly dark fuscous with pale gray apices; a narrow fringe of slender, yellowish brown scales raising along occipital border. Antenna with scape and pedicel covered with yellowish brown scales; basal tuft of elongate black-tipped, bluff scales arising from anterior margin of scape; flagellum with yellowish brown scales dorsally to apex. Maxillary palpus with pale yellowish brown scales at base, mostly fuscous on distal one-half. Labial palpus with segment I dark fuscous laterally, otherwise pale yellowish brown; segment II mostly pale yellowish brown, suffused with fuscous laterally; apical segment pale yellowish brown, with a few fuscous scales scattered on dorsal one-half.

Thorax (Figure 32): Mesonotum (partially denuded in ho-

lotype) yellowish brown with lateral and anterior suffusion of dark fuscous; metanotum with large tuft of elongate, yellowish brown, gray-tipped scales projecting caudally. Tegulae mostly dark fuscous; scales often with brown bases that are mostly obscured by overlying scales. Prosternum with a narrow collar of raised, grayish fuscous scales. Venter generally sparsely scaled, usually with yellowish brown to pale gray piliform scales. Forewing (partially rubbed) generally fuscous to pale gray, with a few concentrations of dark fuscous to black scales as follows: a prominent, longitudinal streak of black scales along CuP from wing base almost to CuA₂; streak interrupted at middle by a relatively large, oval patch of orange-brown; a smaller, irregular concentration of black and orange-brown scales beyond apex of discal cell; smaller patches of black and orange-brown scales beyond cubital streak and discal area; costal area heavily suffused with fuscous, with slight spotting of orange-brown along costal margin; fringe mostly denuded, with scattered, pale yellowish brown, and fuscous scales. Hindwing rather uniformly grayish fuscous, with long, pale grayish hairs at base of anal area; fringe as in forewing. Legs uniformly pale yellowish brown, without annuli.

Abdomen: Pale yellowish brown with fuscous suffusion dorsally. Corethrogyne pale to dark gray.

Genitalia (Figures 237, 238): As described for genus.

HOLOTYPE (Figure 93).—AUSTRALIA: QUEENSLAND: Hugh Nelson Ra[nge], 20 km south of Atherton, 17.27° S, 145.28° E, 1100 m, ♀, 19 Feb 1998, E.D. Edwards, slides DRD 4117, 4121 (ANIC).

FLIGHT PERIOD.—February (single record).

DISTRIBUTION (Map 1).—Known only from the type locality, which is located in a cool tropical, tableland rainforest at moderate elevation.

ETYMOLOGY.—The species name indicates the generally dark color of the adult and is derived from the Latin *fuscata* (darken, blacken).

REMARKS.—The holotype was collected along a roadside clearing at a sheet illuminated by a 250-watt, mercury-vapor light during the peak of the wet season. The vegetation of this area is generally referred to as “tableland” rainforest as compared with the warmer, more lowland-rainforest characteristic of the region around Cairns. The fauna of the tableland rainforest is generally Australian in composition, in contrast to the predominantly New Guinean character of the rainforests of Cape York Peninsula.

Cnissostages Zeller

Cnissostages Zeller, 1863:147.—Bradley, 1951:178 [type species: *Cnissostages oleagina* Zeller; by monotypy].—Davis, 1984:25.—Nye and Fletcher, 1991:72.

MALE.—Length of forewing 8.0–27.5 mm.

Head (Figure 5): Frons relatively smooth, densely covered with short, slender, suberect scales with truncate to minutely bidentate or tridentate apices; scales of vertex shorter than in

Arrhenophanes and less rough, with those between antennae directed more forward on frons, mostly piliform with acute to minutely bidentate apices. Eye large, interocular index ~1.6. Antenna 0.35–0.4 × length of forewing, 53–58-segmented; biserrate ventrally almost to apex; each serration short, 0.5 to almost equal in length to diameter of flagellomere, bearing numerous sensilla trichodea about equal in length to width of serration; a single row of narrow, appressed scales per segment dorsally; scape rough dorsally, smooth ventrally. Haustellum present but extremely reduced, approximately equal in length to first maxillary palpal segment (Figure 6). Maxillary palpus 3-segmented; third segment minute, approximately one-third length of second segment, barely discernable in some specimens; segments globose, total length of palpus less than one-half length of basal labial palpal segment. Labial palpus 3-segmented, upcurved; vestiture smooth dorsally, moderately rough ventrally but with scales densely packed and even; apical segment noticeably depressed; ratio of segments from base: 1:1.6:1.7.

Thorax: Forewing (Figure 33) moderately broad, W/L index 0.42–0.46; apex moderately round, subacute; radius 5-branched; R2 and R3 stalked approximately one-third their total length; R4 and R5 separate; accessory cell present but chorda weak; base of M weakly forked within discal cell. Hindwing similar in size to forewing, W/L index 0.50–0.53; base of M weakly forked within discal cell; 1A almost straight, only slightly curved; frenulum consisting of a single large bristle. Foreleg with epiphysis well developed, almost one-half length of foretibia.

Abdomen (Figure 43): Eighth sternum similar to *Arrhenophanes* but with coremata present, bearing a dense cluster of numerous, slender scales.

Genitalia: Vinculum-saccus V-shaped; saccus elongate, more than 0.6 × length of valva; anterior end slightly swollen. Tegumen generally similar to *Arrhenophanes* but with caudal apex broader and slightly concave in *C. oleagina*. Apotheca

variable, from ~0.4 to more than 1.25 × length of valva. Valva with apex rounded, simple; apical lobe of sacculus variable, either bifurcate, but less so than in *Arrhenophanes*, with inner margins of fork irregularly serrate, or acuminate. Vitta moderately lengthened, less than length of aedoeagus, with sharp 90° bend.

FEMALE.—Length of forewing 20–32 mm. Similar to male except antenna approximately one-third to one-half length of forewing, 49–55-segmented, and strongly biserrate to bipectinate to apex; rami either lobate to subacute (in *C. oleagina*) and more than one-half diameter of shaft, or much longer (in *C. mastictor*) and 4 times diameter of shaft. Frenulum consisting of a cluster of about 7 or 8 smaller bristles.

Abdomen: Seventh segment slightly shortened, entirely encircled by dense cream white corethrogyne scales.

Genitalia: Posterior apophyses greatly lengthened, 1.6–2.0 × length of anterior pair. Eighth sternum projecting caudally free from rest of segment less than one-fourth its length, with ostium opening terminally. Caudal margin of lamella antevaginalis sinuate to slightly lobed. Lamella postvaginalis with either a slightly sinuate caudal margin, or more developed as a triangular lobe projecting slightly beyond posterior margin of lamella antevaginalis. Antrum a moderately broad, thickened tube extending two-thirds to three-fourths length of eighth segment; beyond antrum, ductus bursae a more slender, membranous tube that dilates a short distance before junction with ductus seminalis; length of ductus seminalis more than ~0.75 × length of posterior apophysis. Corpus bursae moderately reduced, only slightly longer than antrum.

REMARKS.—This New World genus is similar to the Australian *Notiophanes* in having all five radial veins terminating on the forewing margin but differs in the staking of R2 and R3, which are separate in *Notiophanes*. All other genera of *Arrhenophanes* have only four branches of the radial vein reaching the margin.

Key to the Species of *Cnissostages*

1. Discal cream spot of forewing reduced, covering less than one-sixth length of cell [Figure 99]. Sacculus lobe of male valva elongate, acuminate [Figure 160] *C. osae*, new species
 Discal cream spot enlarged, covering much of distal one-third of cell [Figures 94–96].
 Male sacculus lobe shortly furcate, lined with numerous short, stout spines [Figure 156] 2
2. Apical one-fourth of forewing predominantly dark fuscous to black [Figure 98].
 Length of forewing 18–28 mm in male, 28–32 mm in female. Antennal rami longer than in *C. oleagina*, equal in length to diameter of shaft in male, 4 × diameter of shaft in female [Figures 15, 25] *C. mastictor*
 Apical one-fourth of forewing much paler, with less black scaling [Figures 94–97].
 Length of forewing 8–19 mm in male, 20–22 mm in female. Antennal rami shorter, length 0.5 × diameter of shaft in male, almost equal to shaft diameter in female [Figures 14, 20] *C. oleagina*

Cnissostages oleagina Zeller

FIGURES 5, 13, 14, 20-24, 33, 43, 46, 94-97, 149-153, 239, 240; MAP 2

Cnissostages oleagina Zeller, 1863:147.—Bradley, 1951:184.—Davis, 1984:25.—Nye and Fletcher, 1991:72.

MALE (Figures 94-96).—Forewing length 8-19 mm.

Head: Vestiture white to pale cream. Antennal scaling of similar color; flagellum $\sim 0.4\times$ length of forewing, 56-58-segmented; flagellum subserrate ventrally, with rounded lobes $\sim 0.5\times$ diameter of antenna (Figure 13). Labial palpus mostly white to pale cream, with dark fuscous laterally along segments I and II.

Thorax (Figure 33): White to pale cream with small tuft of spatulate, occasionally brown-tipped scales. Forewing predominantly pale cream to pale golden brown variably marked with darker brown to fuscous; a large, roughly oval to rectangular, whitish to cream, semitransparent discal patch covering outer one-half of discal cell; basal one-third of spot sometimes with irregular, light suffusion of brownish scales; outer margin of spot and discal cell usually with dark fuscous border; costal area and often anal area of wing grayish brown; sometimes pale cream banding across darker costal area; area beyond discal spot usually heavily marked with fuscous to black; submarginal area of termen brown to fuscous, with highly variable pattern of small whitish spots; spots often arranged in 1 or 2 rows of 3-6 spots each, parallel to termen; fringe white to darker torus, with faint banding. Hindwing mostly off-white, variably sprinkled with fuscous scales, forming in more well-marked specimens a distinct pattern of 2 or 3 concentric rows of small whitish spots; the outer, submarginal row usually the smallest; small black spot at lower outer margin of discal cell; larger black spot also present near apex of 3A. Foreleg off-white to pale cream, with dark fuscous suffusion on dorsal-mesal surfaces of coxa, femur, and tibia; mid- and hindlegs uniformly white to pale cream.

Abdomen (Figure 43): Uniformly white to pale cream, often with loose tuft of slender, spatulate scales from tergum of A2.

Genitalia (Figures 149-153): Vinculum-saccus Y-shaped; saccus elongate, more than $0.6\times$ length of valva; anterior end slightly swollen. Apotheca greatly reduced, less than $0.4\times$ length of valva, and only extending to base of saccus. Anellus tapering to slender, ventrally clefted apex. Valva with apical lobe of saccus enlarging to form a chelate process with serrations along its inner margins similar to *C. mastictor*. Aedeagus $\sim 2\times$ length of valva, terminating in a pronounced 90° bend, slightly curved for a short distance and then curving sharply anteriorly for almost one-half length of the aedeagus (Figure 153).

FEMALE (Figures 14, 97).—Forewing length 18.0-22.2 mm. Color pattern generally similar to male. Antenna $\sim 0.5\times$ length of forewing, 53-55-segmented; flagellum bilaterally serrated,

with short, rounded lobes relatively larger than in male, $\sim 0.8\times$ diameter of antennal shaft in length (Figures 14, 20-24), decreasing in size distally.

Abdomen: Similar to male except with cream to pale brown corethrogyne scaling encircling A7.

Genitalia (Figures 239, 240): Caudal margin of lamella antevaginalis produced into a short, triangular lobe; caudal lobe of lamella postvaginalis more elongated than in *C. mastictor* and with an acute, triangular projection. Caudal end of antrum only slightly broader than middle; diameter of ductus bursae then becoming greatly reduced for a moderate distance before dilating again with thickened walls; entire length of ductus bursae (including antrum) almost $3\times$ length of anterior apophysis. Ductus seminalis more than $1.5\times$ length of anterior apophysis, joining ductus bursae midway along its length; corpus bursa moderately reduced, only slightly longer than antrum.

TYPE.—Lectotype ♀ (present designation); Venezuela: "Type"; "Zeller Coll., Walsingham Collection, 1910-427, 102204"; "*Cnissostages oleagina* Z., E.Z. 1863, 147. f.8, Venezuela"; "*Cnissostages oleagina* Zell., Stett. Ent. Zeit. 24 p 147 (1863), Type ♂" [sic]; "♀ genitalia on slide 23652, D.R. Davis"; "Photograph on file USNM"; (BMNH). Because some uncertainty existed as to the correct sex of the two specimens Zeller originally listed in the type series of this species (see "Remarks"), I have selected the one known extant specimen (female) as lectotype.

HOST.—"... lebt die Raupe in Baumschwämmen" [the larva lives in tree fungi] (Zeller, 1863:149).

FLIGHT PERIOD.—Collection records, although often incomplete, indicate that the adults are generally active throughout the year. Captures have been reported for every month except August and September.

DISTRIBUTION (Map 2).—This species ranges widely through the Neotropical Region from Sinaloa, Mexico, to southern Brazil and Paraguay.

MATERIAL EXAMINED.—BOLIVIA: [Locality not stated]: 1♂, [no data] (BMNH). BRAZIL: [Locality, date not stated]: 1♂ (MNHU). ESPIRITU SANTO: Linhares, 40 m: 1♂, 5-9 Apr 1992, V.O. Becker, slide USNM 31740 (VOB). [Locality not stated]: 1♀, [no data] (BMNH). PARÁ: Belém, 20 m: 5♂, 1♀, 21-26 Dec 1984, V.O. Becker, 53562 (VOB). RIO DE JANEIRO: Campo Bella: 1♂, 24 Feb 1927, slide USNM 30995 (USNM). Petrópolis: 1♀, 1893, Schaus (BMNH). RIO GRANDE DO SUL: Pelotas: 1♂, 16 Dec 1960, C.M. Biezanko (BMNH). SANTA CATARINA: Neue Bremen, Rio Laeiss: 1♂, Jan 1931; 1♂, [no date], Hoffman (BMNH). Hills between Hansa and Jaraguá [do Sul]: 1♀, Mar 1935, Maller (BMNH). São Joaquim, 1400 m: 1♂, 22-24 Jan 1983, V.O. Becker, slide DRD 3623 (VOB). SÃO PAULO: Alto da Serra: 1♂, Mar 1920; 1♂, Mar 1922; 1♀, Mar 1925; 1♂, Apr 1927; 1♀, Nov 1928, R. Spitz (BMNH). Est. Biol. Boracéia, near Salesópolis, 850 m: 1♂, 11 Mar 1972, E.G. & E.A. Munroe (CNC). Santos: 1♀, Mar 1913, Jones (BMNH). COSTA RICA: CARTAGO: Turrialba, 600 m: 1♀, 8

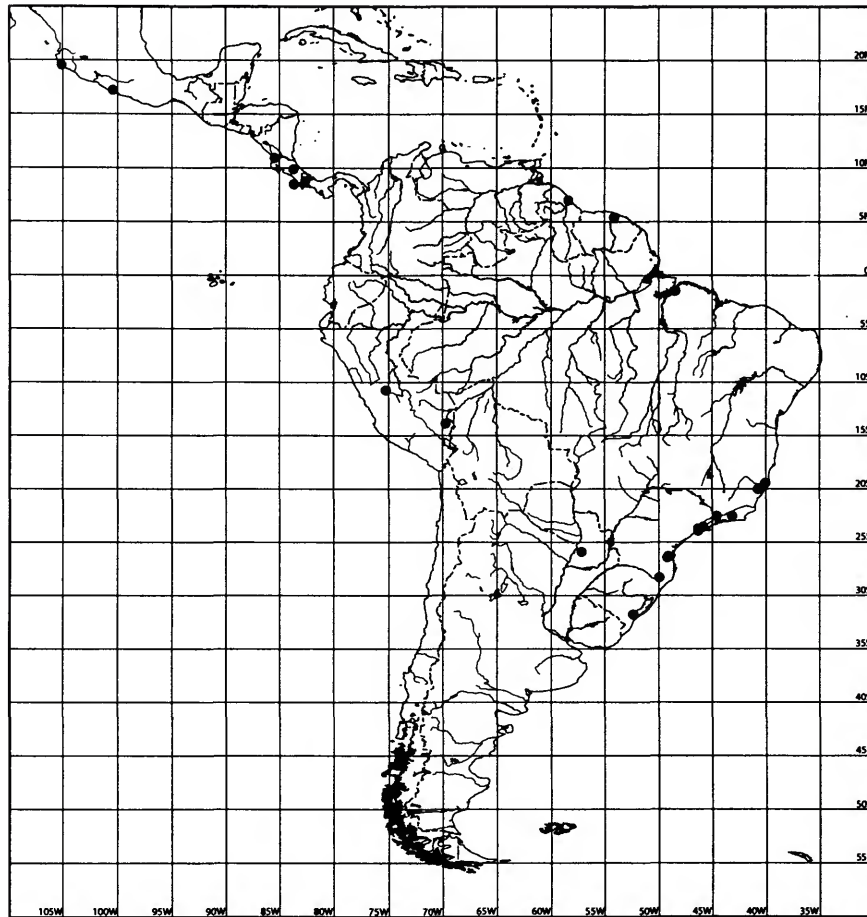
MAP 2.—Distribution of *Crissostages oleagina*.

Apr 1983, V.O. Becker (VOB). GUANACASTE: Estación Mengo, SW side Volcan Cacao, 1100 m: 1 ♀, Jul 1987, Janzen & Hallwachs, slide USNM 32062 (USNM). PUNTARENAS: Estación Sirena, Parque Nacional Corcovado, 0–100 m: 2 ♂, Feb 1992; 2 ♂, May 1992; 1 ♂, Jun 1992; 2 ♂, Nov 1990, G. Fonseca (INBIO, USNM). FRENCH GUIANA: SAINT LAURENT DU MARONI: St.-Jean du Maroni: 1 ♂, [no date], L. Moullet (BMNH); 1 ♂, [no date], slide BMNH 23653 (BMNH). [Locality not stated]: 1 ♀, [no date], C. Bar (BMNH). GUYANA: WEST DEMERARA-ESSEQUIBO COAST: Essequibo River: 2 ♀, [no date], Whiteley (BMNH). MEXICO: GUERRERO: 18 mi [29 km] N. Atoyac: 1 ♀, 9–10 Jun 1994, N. Blumfield (UCB). JALISCO: Estación Biología Chamela: 1 ♂, 20–27 Jul 1984, slide USNM 32318, 1 ♂, 28 Jul–2 Aug 1984, J. Chemsak & J. Doyen, at light, slide DRD 4120 (UCB, USNM). SINALOA: Venadío: 2 ♂, [no date], B.P. Clark, slide USNM 22987 (USNM). PANAMA: Chiriquí: 1 ♀, [no date], Coll.

Staudinger, 251 Wlsh. 1893 (MNHU). PARAGUAY: PARAGUARI: Cerro Acahay: 1 ♂, 13–14 Mar 1986, M. Pogue & M. Solis (USNM). PERU: PASCO: Tambo Eneñas to Dos de Mayo, Camino al Pichis: 1 ♂, 5 Jul 1920, [no leg] (CU). PUNO: Santo Domingo, S.E. Peru: 1 ♀, Nov 1904, Ockenden (BMNH). VENEZUELA: [Locality not stated]: 1 ♀, [no data] (BMNH); 1 ♀ (lectotype), [no data], “Type,” slide BMNH 23652 (BMNH).

REMARKS.—The males examined of this species are quite variable in size and color pattern. The forewings of *C. oleagina* appear generally paler, with less dark apical scaling than in *C. mastictor*. Although the male genitalia are similar to that of *C. mastictor*; the two species, especially the females, can be distinguished by the shorter antennal rami of *C. oleagina*.

Zeller (1863) described *C. oleagina* from two specimens: “Vorderflügel ♂ 10 ½” [lines], ♀ 8 ½” lang.” The “male” originally was deposited in his collection (since transferred via

Walsingham to the Natural History Museum, London), and the female was stated to be in the Kadenschen collection. Zeller erred in sexing his syntype "male" and may have erred also in the case of the female in the Kadenschen collection (not examined in this study). I have dissected the London specimen and have verified it as being a female. Its abdomen had been damaged, perhaps by a dermestid beetle, resulting in the loss of the corpus bursae. Zeller's measurement for the forewing length of the "male" syntype of 10.5 lines (=22.89 mm), which exceeds the maximum for any male examined in the course of this study, is almost the same as my measurement (22.2 mm) of the "type male" in the Natural History Museum. Partly to correct this error in sex, I have designated this specimen as the lectotype. The forewing length of Zeller's female syntype (8.5 lines =18.53 mm) falls within the observed size range of both male and female *C. oleagina*.

Zeller also reported that the larvae of this species feeds on a species of wood-decay fungus.

Cnissostages mastictor Bradley

FIGURES 15, 25–28, 98, 154–157, 241; MAP 3

Cnissostages mastictor Bradley, 1951:184.—Davis, 1984:25.

Cnissostages tantiliza Bradley, 1951:178 [lapsus calami].

MALE.—Forewing length 18.5–27.5 mm.

Head: Similar in color to *C. oleagina*. Antenna $\sim 0.35 \times$ length of forewing, 52-segmented; flagellum similar to that of *C. oleagina*, except with rounded serrations slightly longer, almost equal to diameter of shaft.

Thorax: Similar to *C. oleagina*. Forewing generally larger than *C. oleagina*, predominantly pale golden brown with much darker, broad, brownish fuscous suffusion beyond cream discal patch, continuing more or less obliquely to tornus; apical region of wing with an irregular, pale cream, oblique band from costa, terminating in 2 or 3 irregular cream spots; a similar large spot at costal subapex; basal two-thirds of wing traversed by 1 or 2 irregular bands of darker brown to fuscous; termen mostly fuscous except cream along medial veins adjacent to narrow submarginal spot. Hindwing predominantly pale cream, lightly dusted with brown, gradually becoming paler toward outer margin, with an irregular pattern of 3 or 4 rows of variably sized, circular spots of pale cream aligned parallel to outer margin; innermost row of 4 or 5 spots generally the largest, with the outer, submarginal, mostly confluent row of spots the smallest, most narrow; a small, dark fuscous spot near lower, distal margin of discal cell; a larger fuscous spot on anal margin; fringe mostly cream, gradually becoming more brown toward apex; usually a thin brownish fuscous, submarginal line from apex to M3. Foreleg as described for *C. oleagina* except

also with fuscous suffusion dorsally on first tarsomere; midleg cream with pale brownish suffusion dorsally; hindleg white to cream.

Abdomen: As described for *C. oleagina*.

Genitalia (Figures 154–157): Very similar to *C. oleagina* except proportionately larger. Caudal apex of anellus broader.

FEMALE (Figures 25–28, 98).—Forewing length 28–32 mm. Color pattern similar to male. Antenna $\sim 0.33 \times$ length of forewing, 49- or 50-segmented; flagellum bipectinate (Figures 15, 25, 28), with lateral branches $\sim 4 \times$ diameter of shaft, and several times longer than those of female *C. oleagina*.

Genitalia (Figure 241): Caudal margin of lamella antevaginalis only slightly convex, with a slight median undulation; lamella postvaginalis almost truncate caudally, with a slight median undulation. Antrum broadly flared to ostium, $\sim 0.4 \times$ length of anterior apophysis; ductus bursae then becoming membranous, diameter reduced (corpus bursae missing).

TYPE.—Holotype σ ; COSTA RICA: Drossi [Orosí], 1200 m (BMNH).

FLIGHT PERIOD.—November (single record; other specimens examined without capture data).

DISTRIBUTION (Map 3).—Known from Costa Rica to Peru.

MATERIAL EXAMINED.—COSTA RICA: CARTAGO: Drossi [Orosí], 1200 m: 1 σ (holotype), coll. Fassl, slide BMNH 2176 (BMNH). ECUADOR: [locality not stated]: 1 σ (paratype) (BMNH). NAPO: 3 km N Pacto Sumaco, 1650 m: 1 σ , 14 Nov 1995, J. Hillman, disturbed forest (CMNH). PERU: SAN MARTIN: Moyobamba: 1 σ (allotype), 1888, M. de Mathan, slide BMNH 2171 (BMNH). PUMAYACU: 1 σ , 1 σ , 1 σ , slides USNM 28461, 28473, 28551 (USNM).

REMARKS.—Bradley (1951) distinguished *C. mastictor* from its sister species, *C. oleagina*, primarily by its darker coloration. In addition, there is their obvious but slightly overlapping size differences—specimens of the same sex of *C. mastictor* average almost twice the wingspan of *C. oleagina*. Morphologically the two species appear quite close. Female *C. mastictor* are distinct in having antennal rami more than six to eight times length of those possessed by *C. oleagina* and have the caudal margins of both the lamellae ante- and post-vaginales more truncate. Bradley (1951:178) mentioned the difference in female antennal pectination between *C. oleagina* and "*tantiliza* sp. n.," a name he mistakenly used for *C. mastictor*, which is described six pages later.

Considering this species' large size and broad geographic range, it is surprising for so few specimens to have been collected, particularly from such relatively well-surveyed areas as Costa Rica. With the notable exception of a male from Ecuador collected in 1995, all other specimens examined are believed to have been collected prior to 1900.

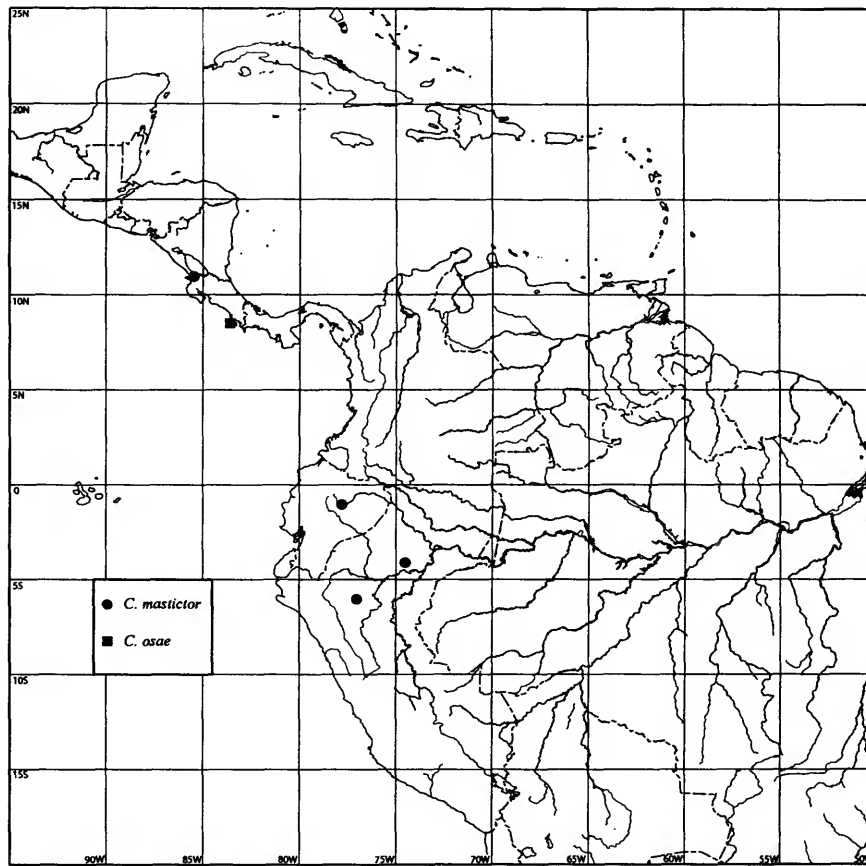

MAP 3.—Distribution of *Cnissostages mastictor* and *C. osae*.

Cnissostages osae, new species

FIGURES 99, 158–161; MAP 3

MALE (Figure 99).—Forewing length 11 mm.

Head: Vestiture mostly pale golden to yellowish brown, becoming more pale on lower part of frons. Antenna $0.4\times$ length of forewing, approximately 55-segmented; scape and dorsal surface of flagellum pale golden to yellowish brown; venter subserrate, lobes almost equal to diameter of shaft in length. Labial palpus predominantly yellowish brown, dark fuscous dorsally and laterally on segments I and II, dorsally on III.

Thorax: Uniformly pale golden to yellowish brown, including mesonotal tuft and venter. Forewing with basal two-thirds almost uniformly brown obliquely to tornus, except for pale yellow discal spot; apical one-third generally pale yellow, with numerous (20+), pale yellow, mostly round spots of varying sizes outlined with brown; termen bordered by a narrow brown band; fringe pale yellow, except brown at tornus. Fore-

leg pale yellowish brown, suffused with fuscous dorsally on coxa, femur, and tibia; midleg similar in color but with less fuscous dorsally on femur and tibia; hindleg mostly yellowish brown, cream dorsally.

Abdomen: Almost unicolorous; cream dorsally, dull white ventrally.

Genitalia (Figures 158–161): Saccus slender, elongate, $\sim 0.7\times$ length of valva. Apotheca well developed, surpassing apex of saccus. Anellus triangular, tapering to a slender caudal apex. Valva with apical lobe of sacculus smooth, acute, extending almost as long as apex of valva. Aedoeagus $1.25\times$ length of valva; extruded vitta $2.3\times$ length of aedoeagus.

FEMALE.—Unknown.

HOLOTYPE (Figure 99).—COSTA RICA: PUNTARENAS: Sirena, Corcovado National Park, Osa Peninsula, σ , 5 Feb 1981, Janzen & Hallwachs, slide USNM 30436 (USNM).

PARATYPES.—COSTA RICA: PUNTARENAS: Estación Sirena, Corcovado National Park, 0–100 m: 1 σ , Apr 1992; 1 σ ,

May 1992, G. Fonseca, L-S 270500, 508300 (INBIO).

FLIGHT PERIOD.—February, April, and May.

DISTRIBUTION (Map 3).—Known only from the Osa Peninsula of southern Costa Rica.

ETYMOLOGY.—The species name is derived from the general type locality, located on the Osa Peninsula of Costa Rica.

REMARKS.—The small, pale, discal spot and generally paler distal one-third of the forewing easily distinguish *C. osae* from the other members of *Cnissostages*. The elongate, acute, distal process of the male sacculus (Figure 160) also differs considerably from the spinose, furcate process present in *C. oleagina* and in *C. mastictor*.

Dysoptus Walsingham

Dysoptus Walsingham, 1914:374 [type species: *Dysoptus probata* Walsingham, 1914:374, by original designation and monotypy].—Fletcher, 1929:72.—Clarke, 1970:47.—Davis, 1984:5, 21.—Becker, 1984:194.—Nye and Fletcher, 1991:101.

Ecpathophanes Bradley, 1951:181 [type species: *Ecpathophanes anachoreta* Bradley, 1951:183; by original designation].—Davis, 1984:6, 25.—Nye and Fletcher, 1991:103. [New synonym.]

MALE.—Length of forewing 3.8–10.8 mm.

Head (Figures 7, 8): Vestiture generally rough, but with scales of lower one-half of frons more densely packed and uniformly short, bi-quadridentate; scales of upper frons and vertex longer and more slender and partially directed down over frons; scales of vertex shorter than in *Arrhenophanes* and less rough, mostly piliform with minutely bi-tridentate apices. Eye large, interocular index 1.6–1.7. Antenna 0.25–0.4× length of forewing, 30–52-segmented, serrated ventrally almost to apex; each serration short, 0.5× or less in length to diameter of flagellomere, bearing numerous sensilla trichodea about equal in length to width of serration; a single row of narrow, appressed scales per segment dorsally; scape rough dorsally, smooth ventrally. Haustellum extremely reduced, 1–2× length of first maxillary palpal segment (Figure 8). Maxillary palpus usually 3-segmented; third segment minute, approximately one-third length of second segment, absent in some species; segments globose, total length of palpus less than one-half length of basal labial palpal segment. Labial palpus 3-segmented, similar to *Cnissostages* except with apical segment more round to compressed; ratio of segments from base: ~1:1.5:1.2.

Thorax: Forewing (Figures 34–36) moderately broad, W/L index 0.43–0.47; apex distinct to round; venation similar to *Arrhenophanes*; radius 4-branched; R2 and R3 stalked approximately one-third to one-half their total length; R4 and R5 fused, terminating either slightly above or at apex; accessory cell absent; base of M not forked within discal cell. Hindwing similar in size to forewing, W/L index 0.42–0.52; base of M not forked within discal cell; 1A only slightly curved, almost straight; frenulum consisting of a single large bristle. Foreleg with epiphysis well developed, ~0.6× length of foretibia.

Abdomen: Eighth sternum similar to *Cnissostages*, paired coremata either present or absent.

Genitalia: Vinculum-saccus Y-shaped; saccus usually elongate but variable, 0.3–1.0× length of valva; anterior end usually swollen. Tegumen generally similar to *Arrhenophanes*, with caudal apex acuminate. Apotheca variable, undeveloped in *D. avittus* and *D. spilacris* to approximately length of valva. Valva with apex typically rounded, simple, but broad and concave in *D. argus*; apical lobe of sacculus highly variable, usually produced and dentate, greatly elongated and spinate in a few species. Vitta variably developed, from absent in *D. avittus* to >7× length of aedoeagus in *D. spilacris*, usually with sharply angled bend near base from junction with aedoeagus.

FEMALE.—Length of forewing 7.0–12.0 mm. Similar to male except antenna approximately one-third to one-half length of forewing, 39–60-segmented, and serrate to apex; serrations subacute and less than one-half diameter of shaft. Frenulum consisting of a cluster of 4 or 5 smaller bristles.

Abdomen: Seventh segment slightly shortened, entirely encircled by dense cream white to brown corethrogyne scales.

Genitalia: Posterior apophyses greatly lengthened, 1.6–2.3× length of anterior pair. Eighth sternum projecting caudally free from rest of segment less than one-third to one-half its length, with ostium opening terminally. Caudal margin of lamella antevaginalis variable, either slightly sinuate, appendiculate, to strongly tapered. Lamella postvaginalis truncate to sinuate, or caudal margin developed as a triangular lobe projecting beyond posterior margin of lamella antevaginalis. Antrum a slender to moderately broad, thickened tube extending 0.75–2.0× length of eighth segment; caudal to antrum, ductus bursae usually a more slender, membranous tube, joining ductus seminalis along anterior 0.33–0.5× length of latter; length of ductus seminalis variable, from less than 0.25 to 2.3× length of posterior apophysis. Corpus bursae reduced, usually less than antrum in length.

REMARKS.—*Dysoptus* is the largest genus in the family, with 16 species recognized. Because the genus resided in the Tineidae until Becker (1981) noted its true family affinities, Bradley (1951) probably was unaware of its existence and proposed the new genus, *Ecpathophanes*, for his new species, *E. anachoreta*, and for “*Arrhenophanes*” *chiquitus* Busck. On the basis of their similar venation and male genital morphology, *Ecpathophanes* is herein synonymized under the senior name. Following in part the interpretation of previous authors, Bradley believed that the relative termination of the radial veins on the forewing margin determined their homology. Consequently, he distinguished *Arrhenophanes* from *Dysoptus* (= *Ecpathophanes*) by vein 10 (R2) being absent and 8 and 9 (R3 and R2) stalked in the former genus, and 7 (R5) absent with 9 and 10 (R3 and R2) stalked in the latter. By emphasizing instead the comparable origins of the radial veins from the discal cell, I have concluded that R2 and R3 are stalked in most *Arrhenophanidae*. I consider the venation of *Arrhenophanes* and *Dysoptus* to be similar, except for the different termination of R3 in respect to the apex of the forewing. I also have assumed that one radial vein has disappeared by the fusion of R4 with R5.

Key to the Species of *Dysoptus*¹

1. Inner surface of male valva with a subapical, pedunculate scale tuft [Figures 188, 189] 2
 Inner surface of valva without subapical, pedunculate scale tuft 3
2. Wings with large white to yellowish white spots along costa and termen greater in diameter than interocular distance [Figures 106, 107]. Male genitalia with apex of valva more broadly rounded [Figure 188]; saccus ~0.6× length of valva [Figure 187] *D. chiquitus*
 Wings with white spots along costa and termen reduced, less than interocular distance [Figure 109]. Apex of valva narrowly rounded [Figure 193]; saccus ~0.8× length of valva [Figure 192] *D. tantalota*
3. Wings predominantly white, lightly spotted with small, irregular, black to fuscous markings [Figures 101, 119] 4
 Wings darker, predominantly brown to dark fuscous. 5
4. Male genitalia with broad valva, gradually widening to concave distal margin [Figure 224]; a spinose pouch present immediately ventrad to rectum [Figure 225]
 *D. argus*, new species
 Valva slender, with rounded apex [Figure 168]; spinose pouch absent
 *D. pseudargus*, new species
5. Male valvae asymmetrical, with apex of left sacculus greatly extended as a sinuate spine to apex of valva [Figures 210, 211] *D. asymmetrus*, new species
 Valvae symmetrical 6
6. Male valva with apex of sacculus attenuate, forming a long spine extending to apex of valva [Figures 215, 219] 7
 Apex of sacculus variable, not extended as a single large spine to apex of valva 8
7. Apex of forewing pale cream [Figure 116]. Venter of male tegumen with a shallow, subsaphial pit [Figure 217, SO] *D. spilacris*, new species
 Forewing mostly uniformly yellowish brown, without large, subapical, pale cream spot [Figure 115]. Male tegumen without subsaphial pit
 *D. acuminatus*, new species
8. Extruded portion of male vesica (i.e., vitta) undeveloped, with only a sharp, reflexed spine at apex of aedoeagus [Figure 207] *D. avittus*, new species
 Vitta extruded one-third or more length of the aedoeagus [Figure 165] 9
9. Hindwing with a relatively broad, white submarginal band [Figure 100]. Saccular lobe of male valva terminating in a simple rounded knob [Figure 164]
 *D. fasciatus*, new species
 Hindwing variable in color pattern, often spotted or unicolorous, without submarginal band. Saccular lobe not smooth, usually with one or more spines or lobes 10
10. Sacculus of male valva terminating in a process with two or more relatively large, spinose lobes [Figures 197, 201] 11
 Sacculus terminating in a single, often spinose lobe [Figures 177, 180, 184] 12
11. Sacculus terminating in one large and one small, spinose lobe [Figure 197]. Apex of vitta greatly expanded *D. bilobus*, new species
 Sacculus with five distinct, spinose, apical lobes of varying sizes [Figure 201]. Apex of vitta not greatly expanded *D. pentalobus*, new species
12. Saccular lobe of valva bearing 3–6 small, apical, denticulate spines [Figures 180, 184] 13

 Saccular lobe without apical, denticulate spines but with 1 or 2 minute irregular lobes [Figures 172, 177] 14
13. Wings with large white spots concentrated particularly along distal margin of discal cell [Figure 105]. Apical spines of sacculus slightly larger, 3 or 4 in number [Figure 184] *D. anachoreta*
 Wings with white markings primarily restricted to costal margin of forewing; white discal spots greatly reduced in both wings [Figure 104]. Apical spines of sacculus smaller, 5 or 6 in number [Figure 180] *D. denticulatus*, new species

14. Hindwings uniformly dark brownish fuscous [Figure 103]. Saccus of male $\sim 0.9 \times$ length of valva [Figure 175] *D. sparsimaculatus*, new species
 Hindwings mottled with brownish fuscous [Figure 102]. Saccus $\sim 1.2 \times$ length of valva [Figure 171] *D. prolatus*, new species

¹Because of the relative rarity of females available for study, this key is based primarily upon male genitalic characters. Consequently, *Dysoptus probata* (Figures 110, 244, 245), which is represented only by the female holotype in poor condition, is not included in the key.

Dysoptus fasciatus, new species

FIGURES 34, 100, 162–165; MAP 4

MALE (Figure 100).—Forewing length 4.1 mm.

Head: Vestiture off-white. Antenna 33- or 34-segmented, $\sim 0.4 \times$ length of forewing, off-white dorsally. Labial palpus cream, with dark brown suffusion dorsally on segments I and II.

Thorax (Figure 34): Cream dorsally, white ventrally. Forewing shiny cream, with suffusion of yellowish brown along costa and outer margin; usually a slender, oblique, brownish band from distal one-fourth of costa across to tornus, forming a large, faint, subapical spot; fringe cream. Hindwing shiny cream to yellowish brown, with a broad, submarginal, off-white band (sometimes indistinct) edged with brown from costa to tornus; a similar band extending two-thirds across basal one-third of wing from anal margin towards costa; fringe cream to yellowish brown. Foreleg cream with dark brownish suffusion dorsally on tibia and first tarsomere; midleg entirely cream; hindleg paler, almost white.

Abdomen: Cream to yellowish brown dorsally; off-white ventrally.

Genitalia (Figures 162–165): Vinculum-saccus Y-shaped; saccus $\sim 0.7 \times$ length of valva. Apotheca vestigial. Anellus a stout cylinder, with a ventral V-shaped, apical cleft. Valva with apical lobe of sacculus short, stout, subclavate (Figure 164). Aedoeagus with apex sharply bent 90° a short distance to short, extruded vesica that bends 90° anteriorly, extending less than one-half length of aedoeagus (Figure 165).

FEMALE (identification questionable).—Forewing length 9.5 mm. Wings partially denuded, but with faint submarginal banding on wings similar to male.

HOLOTYPE (Figure 100).—VENEZUELA: T.F. AMAZONAS: Cerro de la Neblina, basecamp, $0^\circ 50' N$, $66^\circ 10' W$, 140 m, σ , 1–Feb 1985, W. Steiner and R. Faitout (USNM).

PARATYPE.—Same data as holotype: 1 σ , slide USNM 28403 (USNM).

OTHER MATERIAL EXAMINED.—PERU: LORETO: “Canchakuaya” [=Canchahuayo?], 1 σ , slide BMNH 23654 (BMNH).

FLIGHT PERIOD.—Early February (two records).

DISTRIBUTION (Map 4).—This species probably occurs widely through the lowland rain forests of Amazonia. Currently it has been collected only at the type locality in southern Venezuela and possibly in Peru.

ETYMOLOGY.—The specific name is derived from the Latin *fasciatus* (banded), in reference to the distinctive banding present on the forewing and hindwing.

REMARKS.—The conspicuous subapical band in the forewing and even more prominent submarginal band in the hindwing easily distinguishes *D. fasciatus*. The sacculus of the male is the most simple in form within the genus and consists of a slightly enlarged, rounded lobe (Figure 164). A much larger female from Peru with partially denuded wings may represent the opposite sex of this species.

Dysoptus pseudargus, new species

FIGURES 101, 166–169; MAP 4

MALE (Figure 101).—Forewing length 5.0–5.5 mm.

Head: Vestiture entirely white. Antenna similar to *D. argus*, 40–52-segmented. Labial palpus predominantly white with black scaling dorsally and laterally on segments I and II, extending slightly on dorsum of III.

Thorax: White with faint fuscous apices on spatulate scales from metanotal tuft. Forewing generally similar to *D. argus*, white, lightly suffused with scattered concentrations of brownish to fuscous scales; largest concentration along distal margin of discal spot; the latter similar to *D. argus* in being dull white, rough scaled, appearing greasy, and faintly outlined by pale brown suffusion; a dark, fuscous, elongate, submarginal spot present at apex of wing and a smaller fuscous spot near tornus; fringe white, with faint suffusion of pale gray at apex. Hindwing white, more heavily and irregularly marked with fuscous than in *D. argus*, particularly across basal one-half of wing; a series of 6–8 small fuscous spots scattered along outer wing margin; fringe white. Legs similar in color to *D. argus*.

Abdomen: White.

Genitalia (Figures 166–169): Vinculum-saccus Y-shaped; saccus long and slender, $0.8 \times$ length of valva; anterior end slightly clavate. Apotheca moderately developed, more than $0.6 \times$ length of saccus. Anellus reduced in size, slightly conical, with caudal apex deeply cleft, asymmetrical. Valva slender, with apical lobe of sacculus short and stout, subacute, bearing 2 or 3 minute denticles. Aedoeagus $1.8 \times$ length of valva; extruded vitta well developed, $\sim 2 \times$ length of aedoeagus.

FEMALE.—Unknown.

HOLOTYPE (Figure 101).—PERU: MANU: Pakitza, $11^\circ 56' S$, $71^\circ 18' W$, 250 m, Trail 1 and Playa Trail, σ , 10–11 Sep 1989,

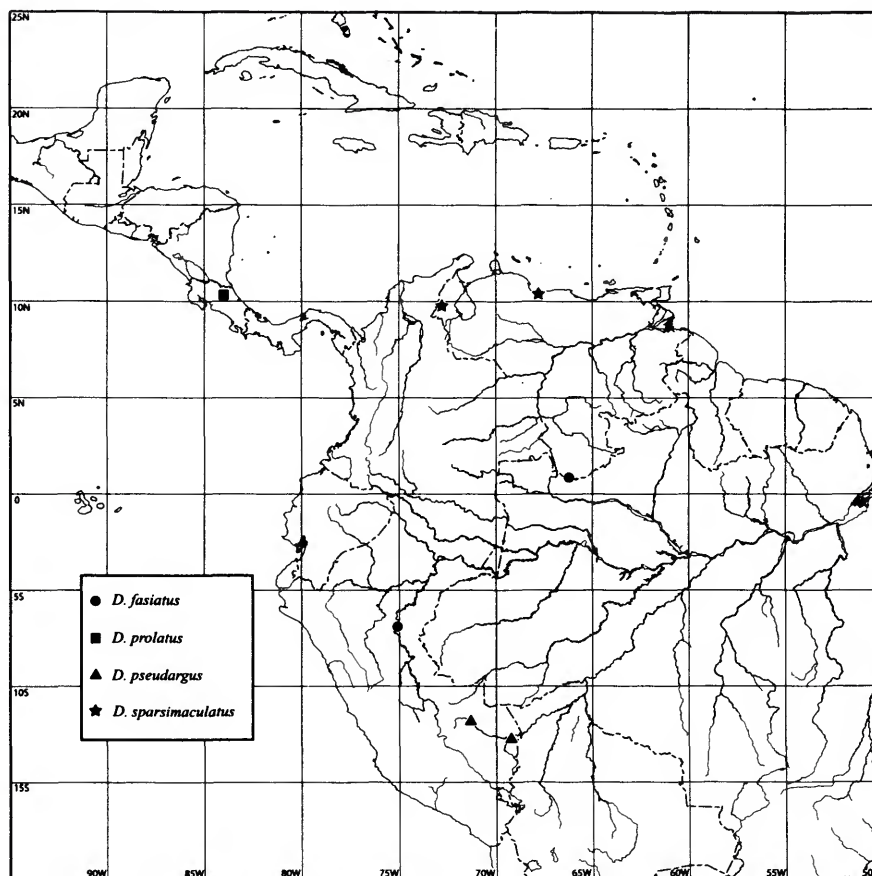

MAP 4.—Distribution of *Dysoptus fasciatus*, *D. prolatus*, *D. pseudargus*, and *D. sparsimaculatus*.

D. Adamski & M. Epstein, slide USNM 30546 (USNM).

PARATYPE.—PERU: MADRE DE DIOS: Rio Tambopata Res., 30 air km SW Puerto Maldonado, 290 m: ♂, 2–5 Nov 1979, J.B. Heppner, slide USNM 30547 (USNM).

FLIGHT PERIOD.—September–November.

DISTRIBUTION (Map 4).—Known only from the lowland Amazonian Region of southern Peru.

ETYMOLOGY.—The specific name is derived from the Greek *pseudos* (fallacy, lie) and *argos* (white), in reference to the superficial similarity of this species to the more apomorphic *D. argus*.

REMARKS.—The wing color of this species resembles *D. argus* in being predominantly white, mottled with irregular clusters of fuscous scales. The male genitalia differ greatly, with that of *D. pseudargus* lacking the elaborate spinose pouch present in *D. argus*. In addition, the valva of *D. pseudargus* is more slender, and the saccular lobe is more simple and consists of a slightly enlarged lobe bearing two or three minute spines (Figure 168).

Dysoptus prolatus, new species

FIGURES 80, 81, 102, 170–173, 248, 249; MAP 4

MALE (Figure 102).—Forewing length 4.0–5.2 mm.

Head: Vestiture pale yellowish brown to cream. Antenna 37–42-segmented, approximately the length of forewing, generally cream with scape and pedicel more brownish. Labial palpus cream, with slight suffusion of dark brownish fuscous scales laterally on segments I and II.

Thorax: Mostly cream dorsally, with scattered, dark brown-tipped scales on tegula and metanotal tuft; scales of patagia more brown; pale golden to yellowish brown ventrally. Forewing yellowish brown, heavily marked with brown to dark brownish fuscous scales, especially along costal margin and distal one-fourth of wing; a slender, irregular, indistinct, outwardly convex band of dark brownish fuscous scales across basal one-third; a distinct, slender, sinuate band of cream bordered with dark brown scales from distal one-third of costa to termen, thereupon band flaring abruptly and forming a large,

triangular cream spot that continues into fringe; fringe cream, with dark brownish fuscous scales near apex and dark-tipped scales along lower portion of termen below cream spot. Hindwing more darkly mottled with brownish fuscous scales, forming an indistinct, dark band across basal one-third and an irregular band of cream partially across distal one-third. Legs mostly shiny yellowish brown, with dark brownish suffusion dorsally on femur, tibia, and first tarsomere of foreleg.

Abdomen: Light brown dorsally, with darker brown scales caudally on terga 7–8; golden yellowish brown ventrally and on genitalia.

Genitalia (Figures 170–173): Vinculum-saccus T-shaped; saccus extremely long and slender, $\sim 1.2 \times$ length of valva. Apotheca greatly lengthened, almost $1.4 \times$ length of saccus. Anellus elongate and slender, gradually tapering caudally to subacute apex. Valva with cucullus abruptly narrowing to subacute apex; apical lobe of sacculus stout, approximately one-half length of cucullus. Aedoeagus extremely long, more than $2 \times$ length of valva; extruded vitta extremely long, $\sim 2 \times$ length of aedoeagus; base of vesica slightly dilated $\sim 0.1 \times$ length of aedoeagus.

FEMALE.—Length of forewing 7.8 mm. Although mostly denuded, wing pattern similar to male, particularly in presence of large, triangular cream spot at forewing apex and heavily mottled hindwings.

Genitalia (Figures 248, 249): Caudal margin of lamella antevaginalis slightly sinuate, with a minute median projection. Lamella postvaginalis extending caudad of lamella antevaginalis approximately one-third length of eighth sternum and tapering to a minutely cleft apex (Figure 248); separation from underlying membrane almost one-half length of the entire lamella postvaginalis. Antrum thick walled, extending length of eighth sternum, with an abrupt, U-turn near anterior end. Ductus bursae extending beyond antrum as a slender, membranous tube about as long as anterior apophysis, gradually enlarging to membranous corpus bursae, with length slightly exceeding eighth sternum. Ductus seminalis very elongate, $\sim 1.5 \times$ length of posterior apophysis, joining ductus bursae approximately midway along latter.

LARVAL CASE (Figures 80, 81).—Length of largest case 17 mm; maximum diameter 2.2 mm. A firm, thin walled, cylindrical, dark gray tube irregularly covered with minute plant fragments.

HOLOTYPE (Figure 102).—COSTA RICA: HEREDIA PROV.: Estación Biología La Selva, $10^{\circ}26'N$, $84^{\circ}01'W$, 50–150 m, σ , 5 Feb 1998, bosque secundario, L/18/309 (INBIO).

PARATYPES.—Same data as holotype, except: 2 σ , 15 Jan 1998, bosque primario, L/00/274, slide USNM 32038; 1 σ , 10 Feb 1999, bosque primario, L/10/569; 3 σ , 15 Jul 1998, bosque primario, L/14/423; 1 σ , 9 Sep 1998, bosque primario, L/10/467; ~ 700 m along CES [Camino Experimental Sur]: 5 σ , 1 ϕ , 19 Apr 2001, DOA 19 Jun 2001, D.R. Davis, DRD 2492, Host:

Phellinus gilvus (Schw.), slides USNM 32384, 32385 (INBIO, USNM).

HOST.—Hymenochaetaceae: *Phellinus gilvus* (Schw.)

FLIGHT PERIOD.—Adults have been collected in January, February, June, July, and September.

DISTRIBUTION (Map 4).—Known only from the type locality and mostly from primary forests of La Selva, Costa Rica.

ETYMOLOGY.—The specific name is derived from the Latin *prolatus* (extended, elongated), in reference to the greatly elongate saccus in the male genitalia of this species.

REMARKS.—Of the four species of *Dysoptus* reported from Costa Rica, this species is most likely to be confused superficially with *D. bilobus*, especially in the case of worn specimens. The male genitalia of *D. prolatus* differ from the other three species in having the most elongate saccus and apotheca (Figures 170, 171). The vesica is likewise of great length, resembling that of *D. spilacris*. The latter species, in addition to its distinct forewing pattern, is unusual in lacking an apotheca and has a more elongated, acute saccular lobe (Figure 219).

More than 20 larval cases of this species were collected 19 April 2001 attached to numerous, relatively small (up to 6 cm across) shelf fungi (*Phellinus gilvus*) that were growing on the standing trunk of a dead tree. The tree was located near trail marker 500, along the Camino Experimental Sur (CES) at the La Selva Biological Reserve, near Puerto Viejo, Heredia Province, Costa Rica. Similar (but empty) larval cases, on what appeared to be the same species of fungus, had been observed at other locations in the Reserve on previous trips. Several cases at the CES site contained live larvae. During the following month, these were observed to move over the surface of the fungus. After about one month all activity ceased, and the cases became firmly attached to the host. On 19 June 2001, five males and one female were found dead in the rearing container.

Dysoptus sparsimaculatus, new species

FIGURES 103, 174–177; MAP 4

MALE (Figure 103).—Forewing length 4.6–5.0 mm.

Head: Vestiture pale brownish fuscous, with suffusion of pale gray on lower part of frons. Antenna 33- or 34-segmented, $\sim 0.4 \times$ length of forewing, brownish fuscous dorsally, pale gray ventrally. Labial palpus mostly off-white to grayish white, with pale brown suffusion laterally, especially on segments I and II.

Thorax: Brownish fuscous dorsally, grayish white ventrally. Forewing dark brownish fuscous, slightly marked with yellowish white as follow: a triangular, slender, oblique streak slightly beyond basal one-third of costa sometimes extending to discal cell, a similar costal streak at distal two-thirds, and shorter oblique spot just before apex of wing; termen dark brownish fuscous except for moderately large triangular spot below apex and extending a short distance into wing. Hindwing uniformly dark brownish fuscous. Legs pale brownish fuscous dorsally, pale gray to yellowish brown ventrally.

Abdomen: Brownish fuscous dorsally, pale gray to off-white ventrally. Sternum 7 with a bilateral pair of short coremata.

Genitalia (Figures 174–177): Vinculum-saccus Y-shaped; saccus elongate, almost $0.9\times$ length of valva; apex gradually clavate. Apotheca vestigial. Anellus relatively short, stout; apex symmetrical, caudal margin concave ventrally. Valva with apex of cucullus rounded; caudal lobe of sacculus extending to distal two-thirds of valva, smooth, without spines. Aedoeagus more than $2\times$ length of valva; extruded vitta reduced, approximately one-half length of aedoeagus.

FEMALE.—Unknown.

HOLOTYPE (Figure 103).—VENEZUELA: ARAGUA: Rancho Grande, 1100 m, ♂, 25–26 Jan 1978, J.B. Heppner, slide USNM 30511 (USNM).

PARATYPES.—VENEZUELA: LARA: Yacambu National Park, 1560 m, 13 km SE Sanare: 1♂, 1–5 Aug 1981, cloud forest, J.[B.] Heppner, slide JBH 2020 (FSCA). ZULIA: Los Angeles del Tucuco: 1♂, 15–16 Apr 1981, A.S. Menke (USNM).

FLIGHT PERIOD.—January, April, and August.

DISTRIBUTION (Map 4).—Known from only three montane sites in northern Venezuela.

ETYMOLOGY.—The specific name is derived from the Latin *sparsus* (few, rare) and *maculata* (spotted, marked), in reference to this species' almost immaculate wing pattern.

REMARKS.—This species is unusual in having the most uniform color pattern within the family. The brownish fuscous color of both fore- and hindwings is interrupted by only three slender, pale yellow, costal striae and a larger, triangular spot below the apex of the forewing. The male genitalia of *D. sparsimaculatus* (Figures 174–177) are most similar to that of *D. fasciatus* (Figures 162–165) in the absence of an apotheca and in having a relatively short vitta and simple saccular lobe. The latter is more acute, with a small subapical lobe in *D. sparsimaculatus*.

Dysoptus denticulatus, new species

FIGURES 104, 178–181; MAP 5

MALE (Figure 104).—Forewing length 5.0 mm.

Head: Vestiture brownish fuscous, becoming pale gray on lower frons. Antenna 37-segmented, $\sim 0.4\times$ length of forewing, brownish fuscous dorsally, paler, more grayish ventrally. Labial palpus brownish fuscous dorsally and laterally on all segments, off-white ventrally and mesally.

Thorax: Shiny brownish fuscous dorsally, paler, more grayish ventrally. Forewing very similar to *D. tantalota*, brownish fuscous, lightly marked with pale yellow spots as follows: a moderately large, triangular spot at basal one-third of costa, a much smaller costal spot at distal two-thirds, an elongate spot along costa just before apex, and a single small spot beyond apex of discal cell near R5; fringe fuscous except for elongate subapical spot and a more triangular spot below apex

on termen. Hindwing similar in color except with a single, small, pale yellow spot near apex of discal cell. Foreleg pale gray, with brownish fuscous dorsally on femur, tibia, and first tarsomere; mid- and hindlegs similar in color except brownish fuscous dorsally on entire tarsus.

Abdomen: Brownish fuscous dorsally, pale yellowish brown ventrally.

Genitalia (Figures 178–181): Vinculum-saccus Y-shaped; saccus elongate (apex missing), more than $0.7\times$ length of valva. Apotheca missing [possibly damaged]. Anellus cylindrical, apex deeply cleft about to middle along left side. Valva with cucullus narrowing to subacute apex; pedunculate scale tuft absent; caudal lobe of sacculus elongate, with apical crown of about 6 small teeth. Aedoeagus almost $2\times$ length of valva; extruded vesica (apex missing) longer than aedoeagus.

FEMALE.—Unknown.

HOLOTYPE (Figure 104).—BRAZIL: SÃO PAULO: Boracéia Field Station, Casa Grande, ♂, 19–26 Feb 1975, T. Rogers, slide DRD 3762 (UFPR, donation from FSCA).

FLIGHT PERIOD.—February (one record).

DISTRIBUTION (Map 5).—Known only from the type locality in southern Brazil.

ETYMOLOGY.—The specific name is derived from the Latin *denticulatus* (with small teeth), in reference to the denticulate apex of the saccular process in the male valva.

REMARKS.—Several species of *Dysoptus* have a spinose apex on the saccular lobe of the male genitalia. *Dysoptus denticulatus* appears most similar to *D. tantalota* in wing color and in the structure of the saccular lobe. The valvae of *D. tantalota*, however, have a pedunculate setal tuft (Figure 193) that is absent in *D. denticulatus*. *Dysoptus anachoreta* also bears apical teeth on this structure, but those of *D. anachoreta* (Figure 184) are more coarse and fewer.

Because of minor pest damage to the abdomen of the holotype (resulting in the loss of apical portions of the saccus, vesica, and possibly apotheca), accurate diagnoses of these structures must await the collection of more males.

Dysoptus anachoreta (Bradley), new combination

FIGURES 35, 105, 182–185; MAP 5

Ecpathophanes anachoreta Bradley, 1951:183.—Davis, 1984:25.—Nye and Fletcher, 1991:103.

MALE (Figure 105).—Forewing length 10.8 mm.

Head: Vestiture variable, vertex dark brown, becoming paler, more yellowish brown on lower frons; scales rather slender with bi- to quadridentate apices; scales of vertex somewhat raised and curved forward on frons. Antenna [broken] with scape pale brown irrorated with white. Flagellum covered dorsally with whitish scales suffused with pale brown; subserrate ventrally with a short rounded lobe from each segment $\sim 0.4\times$ diameter of shaft. Labial palpus brown dorsally, pale yellowish

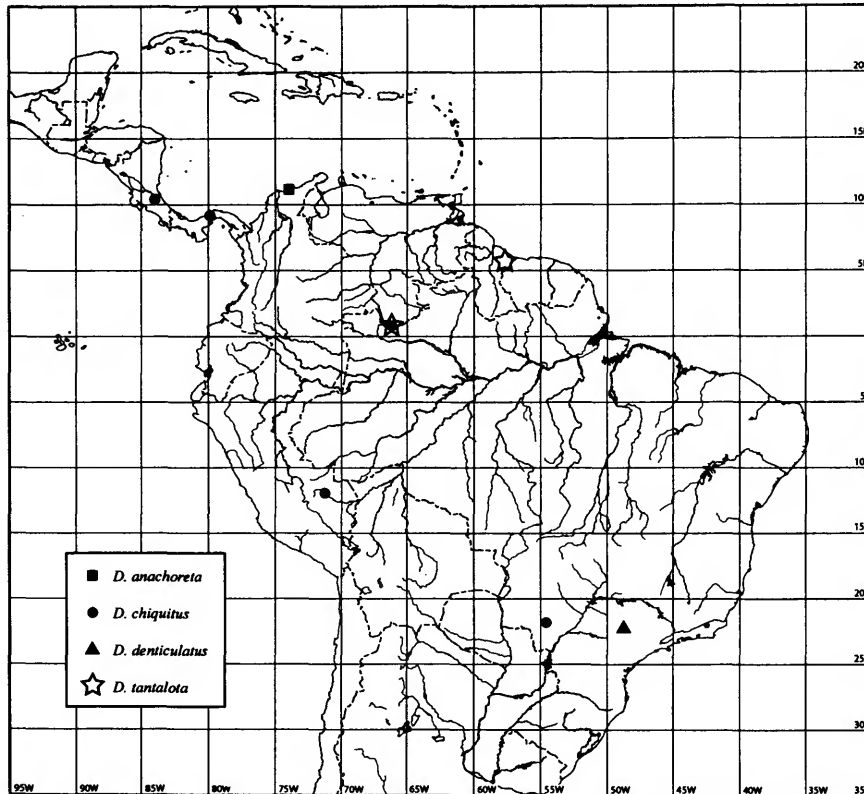

MAP 5.—Distribution of *Dysoptus anachoreta*, *D. chiquitus*, *D. denticulatus*, and *D. tantalota*.

brown ventrally, and pale yellowish brown to dull white mesally.

Thorax (Figure 105): Uniformly dark brown dorsally, white ventrally. Forewing predominantly dark brownish fuscous, with a purplish luster on basal approximately three-fourths, becoming pale golden brown on apical one-fifth; a single, small, round white spot at basal one-third of costa; apical one-fifth of wing marked by several pale yellow spots of varying size, with largest spot forming a very irregular band from costa along apex of discal cell; beyond band an irregular, submarginal row of 3 or 4 small, white spots; a narrow, apical spot and a similar elongate spot bordering termen; fringe cream except for brownish fuscous at apex and along tornus. Hindwing slightly paler with a predominantly dark yellowish brown color marked by a row of 5 pale cream spots near termen, a slender cream band at basal one-third of wing from base of cell to A2, and a large, pale cream spot near apex of cell, narrowing caudally to form a contiguous row of 3 small spots of decreasing size to A1; fringe predominantly pale cream above and below dark brownish apex. Foreleg brownish fuscous dorsally, yellowish white to yellowish brown ventrally; apex of coxa, first tarsal segment, and all of tarsi 2–5 distinctly paler, more whit-

ish. Mid- and hindlegs pale golden brown dorsally, almost white ventrally.

Abdomen: Color not examined.

Genitalia (Figures 182–185): Similar to *D. chiquitus* but with uncus more slender and narrow at base. Saccus abruptly swollen at apex, subclavate. Anellus broad at base, tapering to a narrow, moderately symmetrical apex. Valva with apex more rounded than in *D. chiquitus*; apex of saccular lobe distinctly tridentate. Aedoeagus $\sim 1.25 \times$ length of valva; extruded vitta more than $2 \times$ length of aedoeagus.

FEMALE.—Unknown.

HOLOTYPE (Figure 105).—COLOMBIA: [MAGDALENA]: Sierra del Libano, 6000 ft [1829 m], σ , V.1899, H.H. Smith, slide BM 2138 (BMNH).

FLIGHT PERIOD.—May (one record).

DISTRIBUTION (Map 5).—Known only from the type locality, Sierra del Libano [also known as El Libano], which according to Paynter and Taylor (1981) is a dense subtropical forest and a spur of the Cuchilla San Lorenzo on the southwestern Sierra Nevada de Santa Marta in Magdalena Province ($\sim 11^{\circ}10'N$, $74^{\circ}W$).

REMARKS.—This species appears most allied to *D. chiquitus*

on the basis of both wing pattern and male genital characters. The pale yellow spots beyond the discal cells of both wings are significantly larger in *D. anachoreta* (Figure 105). The spines at the apex of the saccular lobe in *D. anachoreta* are larger and fewer (Figure 184). This species also lacks the pedunculate setal tuft characteristically present on the valvae of *D. chiquitus* and its sister species, *D. tantalota*.

Dysoptus chiquitus (Busck), new combination

FIGURES 106–108, 186–190, 242, 243; MAP 5

Arrhenophanes chiquita Busck, 1914:62.—Walsingham, 1914:433.
Ecpathophanes chiquita (Busck).—Bradley, 1951:184.—Davis, 1984:25.

MALE (Figures 106–108).—Forewing length 4.6–6.5 mm.

Head: Vestiture uniformly off-white. Antenna ~0.3–0.33× length of forewing, 34–36-segmented. Labial palpus off-white, with pale brown suffusion dorsally and laterally on segments I and II.

Thorax: Mesonotum off-white to pale cream, with dark brownish suffusion laterally and caudally; mesonotum with tuft of whitish, spatulate scales with dark brown apices. Venter white. Forewing pattern generally similar to that of *D. anachoreta*; basal two-thirds of wing predominantly dark brownish fuscous, with a small to large, whitish, triangular spot along basal one-third of costa; distal one-third of wing lighter in color, heavily marked by round, whitish spots of varying diameters; usually 2 or 3 moderately large spots beyond distal margin of discal cell, without continuous, irregular submarginal band present in holotype of *D. anachoreta*; fringe mostly pale cream, with dark brownish suffusion at apex and tornus. Hindwing similar in color, with basal one-fourth mostly off-white; a large, pale cream spot beyond apex of discal cell and a much smaller, more slender spot below and slightly contiguous with larger spot; a series of 3 or 4 small, pale cream, subterminal spots bordering outer wing margin; Fringe mostly dark brownish fuscous with white intrusion at apex and midway along termen. Foreleg pale cream with brownish suffusion dorsally along coxa, femur, and tibia. Midleg similar but with paler suffusion of brown. Hindleg uniformly pale cream.

Abdomen: Fuscous dorsally; white to cream ventrally and laterally, with fuscous suffusion on eighth sternum

Genitalia (Figures 186–190): Similar to *D. anachoreta* but with uncus broader at base, more conical. Vinculum-saccus Y-shaped, saccus elongate, ~0.6× length of valva; anterior end gradually enlarged, subclavate. Apotheca well developed, surpassing apex of saccus. Anellus slender to base, with dorsal apex greatly extended beyond aperture, asymmetrical. Valva similar to *D. tantalota*, with cucullus slightly narrowing but more rounded; a slender process bearing a dense tuft of scales arising subapically from inner surface of cucullus; apical lobe of sacculus extended, terminating in 7 or 8 minute, apical to

subapical teeth. Aedoeagus ~1.3× length of valva; extruded vitta 1.7–> 3× length of aedoeagus.

FEMALE.—Forewing length 7.0–7.2 mm. Antenna 0.3× length of forewing, 39-segmented. Similar to male in general color pattern. Seventh segment with dense ring of cream to brownish corethrogyne scales.

Genitalia (Figures 242, 243): Lamella antevaginalis with caudal margin projecting caudad of eighth sternum as a triangular, subacute lobe approximately one-fourth length of sternum. Lamella postvaginalis well developed, almost as broad and as long as main body of eighth sternum, extending beyond apex of antevaginal lobe a distance greater than length of lobe, and projecting free of eighth segmental membrane approximately one-half its length; caudal margin evenly rounded. Antrum an elongate, thick-walled tube about as long as anterior apophysis. Ductus continuing beyond antrum as a moderately slender, membranous duct about as long as posterior apophysis. Ductus seminalis elongate, 1.0–1.2× length of posterior apophysis, joining ductus bursae near anterior one-third of latter. Corpus bursae about as long as antrum.

HOLOTYPE (Figure 106).—PANAMA: CANAL ZONE: Cabima, ♂, May 1911 (USNM).

FLIGHT PERIOD.—Adults are probably active during most months of the year throughout their broad range. Records available thus far include January–March, May, August, and September.

DISTRIBUTION (Map 5).—This species is widespread in a major portion of the Neotropical lowland wet forests, from Costa Rica south to Mato Grosso in southern Brazil.

MATERIAL EXAMINED.—BRAZIL: MATO GROSSO: Rio Brilhante, 1♂, 25 Jan 1971, V.O. Becker, Becker 13692, slide DRD 3624 (VOB). COSTA RICA: HEREDIA PROV.: Estación Biología La Selva, 10°26'N, 84°01'W, 50–150 m: 1♂, 12 Aug 1998, bosque primario, L/10/443; 1♂, 6 Apr 1999, bosque primario, L/10/611 (INBIO). PANAMA: CANAL ZONE: Cabima: 1♂ (holotype), May 1911, A. Busck, slide USNM 28469 (USNM). PERU: MANU: Pakitza, 11°56'S, 71°18'W, 250 m, Trail 1 and Playa Trail: 1♂, 10–11 Sep 1989, D. Adamski & M. Epstein, slide USNM 30545 (USNM). VENEZUELA: T.F. AMAZONAS: Cerro de La Neblina, basecamp, 140 m: 1♂, 3♀, 13–20 Feb 1984, slide USNM 28488; 2♂, 1–10 Mar 1984, slide USNM 22920, D. Davis & T. McCabe; 1♀, 1–9 Feb 1985, W. Steiner; 1♂, 10–20 Feb 1985, R. Faitout & W. Steiner; 2♂, 21–28 Feb 1985, R. Faitout & W. Steiner, slide USNM 28458 (UCVM, USNM).

REMARKS.—This species and *D. tantalota* are closely allied as indicated by the synapomorphy of a prominent pedunculate setal tuft from the male valva (Figures 188, 189). Also morphologically similar are their elongate, asymmetrical anelli. The male genitalia are so similar that the only reliable means for distinguishing the two species is by comparing their wing pattern; *D. chiquitus* has much larger spots on both wings (Figure 107).

Dysoptus tantalota Meyrick

FIGURES 36, 109, 191–194; MAP 5

Dysoptus tantalota Meyrick, 1914:267.—Clarke, 1955:302; 1970:47.—Becker, 1984:194.—Davis, 1984:21**MALE** (Figure 109).—Forewing length 4.1–6.0 mm.**Head:** Vestiture gray, becoming pale gray on lower part of frons. Antenna 33–36-segmented, $\sim 0.33\times$ length of fore-wing; vestiture fuscous dorsally, paler ventrally. Labial palpus pale gray, with heavy suffusion of light fuscous laterally and dorsally on all segments.**Thorax** (Figure 36): Dorsum uniformly fuscous; venter gray to grayish white. Forewing fuscous, lightly spotted with pale yellow as follows: a small, triangular spot at basal one-third of costa, another similar costal spot at distal two-thirds, and a more elongate costal spot just before apex; 1 or 2 small spots located along apex of discal cell; fringe fuscous except where interrupted by elongate subapical costal spot and similar spot midway along termen. Hindwing similar to forewing except sometimes more heavily spotted with pale yellow; a series of 2–4 small spots across basal one-third of wing; a moderately large to small spot near apex of discal cell, being sometimes closely associated with as many as 3 smaller spots below. Foreleg fuscous dorsally, pale gray ventrally; midleg light fuscous dorsally on femur and tibia, pale gray elsewhere; hindleg mostly pale gray.**Abdomen:** Fuscous dorsally, pale grayish to yellowish brown ventrally.**Genitalia** (Figures 191–194): Vinculum-saccus Y-shaped; saccus elongate, almost $0.8\times$ length of valva; anterior end clavate. Apotheca well developed, slightly surpassing anterior apex of saccus. Anellus an irregular cylinder, deeply cleft along left side. Valva very similar to *D. chiquitus*, with apex of cucullus more acute; a slender subapical process bearing a dense tuft of scales (Figure 193) arising subapically as in *D. chiquitus*; apical lobe of sacculus slender, extended, bearing 2 or 3 small apical teeth. Aedeagus almost $1.5\times$ length of valva; extruded vitta elongate, almost $2\times$ length of aedeagus, with apex clavate.**FEMALE.**—Unknown.**HOLOTYPE.**—GUYANA: MAZARUNI-POTARO: Bartica, σ , Feb 1913 (BMNH).**FLIGHT PERIOD.**—February to early March.**DISTRIBUTION** (Map 5).—This species probably occurs widely through the lowland rain forests of Amazonia. Currently it is known only from Guyana and southern Venezuela.**MATERIAL EXAMINED.**—GUYANA: MAZARUNI-POTARO: Bartica: 1 σ (holotype), Feb 1913, Parish, slide JFGC 6723 (BMNH). VENEZUELA: T.F. AMAZONAS: Cerro de la Neblina, 0°50'N, 66°10'W, 140 m: 1 σ , 1–9 Feb 1985, W. Steiner, slide USNM 28445; 1 σ , 1–10 Mar 1984, D. Davis & T. McCabe, slides USNM 30672, 20899 (USNM).**REMARKS.**—As discussed under the preceding species, *D. chiquitus* and *D. tantalota* are sister species with essentiallyidentical male genital morphology and are the only arrhenophanid species with pedunculate setal tufts on the valvae. The two may be distinguished by their different wing patterns, with the markings of *D. tantalota* much smaller (Figure 109). The wing pattern of *D. tantalota* is most similar to *D. probata*, currently known from only the female holotype.The female of *D. tantalota* remains unknown, although additional males agreeing with the holotype have been collected in southern Venezuela.*Dysoptus probata* Walsingham

FIGURES 110, 244, 245; MAP 5

Dysoptus probata Walsingham, 1914:374.—Fletcher, 1929:72.—Becker, 1984:194.—Davis, 1984:21.—Nye and Fletcher, 1991:101.**MALE.**—Unknown.**FEMALE** (Figure 110).—Forewing length 8.0 mm.**Head:** Vestiture uniformly yellowish brown and smooth except for a small lateral pair of occipital tufts. Antenna 41-segmented, $\sim 0.4\times$ length of forewing; scape brown dorsally, paler, more yellowish brown ventrally; flagellum covered with smooth, pale brown scales dorsally to apex; venter naked, densely pubescent; each segment bearing a sublamellate process ventrally, decreasing in size to apical segment. Maxillary palpus pale brown, greatly reduced to 1 or 2 globose segments. Labial palpus evenly curved dorsally almost to top of eye; mostly yellowish brown, except for fuscous suffusion on dorsum of segments 1 and 2.**Thorax:** Dorsum dark brown with a slight purple luster; venter yellowish brown. Forewing dark brown with a slight purple luster and several small, scattered, pale yellow spots, including a more prominent, pale yellow spot at basal one-third and distal one-third of costa and a somewhat larger spot near apex of discal cell; a very small subapical spot near R4; termen with a large, pale yellow spot extending mostly through fringe. Hindwing similar in color to forewing, but slightly paler and more uniform. Foreleg pale brown dorsally, yellowish brown to cream ventrally, without tarsal banding; epiphysis present. Mid- and hindlegs missing.**Abdomen:** Vestiture not examined; a pair of short coremata arising from A7.**Genitalia** (Figures 244, 245): Lamella postvaginalis connate, projecting caudally well beyond caudal margin of lamella antevaginalis. Antrum a sclerotized tube slightly longer than anterior apophyses, gradually narrowing to a short, moderately inflated, minutely wrinkled, strongly curved duct that then constricts and continues anteriorly as a slender membranous tube to elongate, oval, membranous corpus bursae; junction of ductus spermathecae near middle immediately anterior to moderately inflated region of ductus bursae.**HOLOTYPE** (Figure 110).—GUATEMALA: QUEZALTENANGO: Cerro Zunil, 4000–5000 ft [1220–1524 m], ♀, 1890, G.C. Champion, slide BM 12110 (BMNH).

FLIGHT PERIOD.—Unknown.

DISTRIBUTION (Map 5).—Known only from the type locality in southwestern Guatemala.

REMARKS.—The female holotype (Figure 110) is in poor condition and is all that is known of this species. The wing pattern appears most similar to that of *D. tantalota* (Figure 109), whose female is unknown. Until more material, including the missing sexes of either species, is collected, no further assessment of their relationship can be offered.

Dysoptus bilobus, new species

FIGURES 111, 195–198; MAP 6

MALE (Figure 111).—Forewing length 3.8–5.0 mm.

Head: Vestiture uniformly dark grayish brown. Antenna 32–38-segmented, $\sim 0.25 \times$ length of forewing, dark grayish brown scaling dorsally to apex. Labial palpus mostly yellowish brown to pale brown, with dark brownish suffusion laterally.

Thorax: Dark brownish fuscous dorsally; pale, shiny, yellowish brown ventrally. Forewing dark brownish fuscous, with scattered, pale yellow markings as follow: costa with three, short, oblique fasciae at basal one-third, a more triangular fascia at distal two-thirds, and an elongate, costal spot at subapex, the latter continuing into fringe; an elongate spot midway along termen continuing into fringe; 4 small, subterminal spots in an irregular line between termen and discal cell; fringe dark brownish fuscous except where interrupted by pale yellow spots. Hindwing similar to forewing in color but slightly paler; sometimes 1 or 2 small, pale yellow spots near distal one-fifth; fringe dark brownish fuscous, except where interrupted by narrow costal row of pale yellow scales before apex and small, marginal spot below apex. Fore and midlegs yellowish brown to pale brown, lightly suffused with dark brown dorsally on coxa and femur; tibia and first tarsomere dark brownish fuscous dorsally; distal tarsomeres yellowish brown; hindleg generally paler, with only slight, pale brown suffusion dorsally on femur and tibia.

Abdomen: Dark brownish fuscous dorsally, shiny yellowish brown ventrally.

Genitalia (Figures 195–198): Vinculum-saccus T-shaped; saccus slender, elongate, $\sim 0.75 \times$ length of valva. Apotheca reduced, $\sim 0.63 \times$ length of saccus. Anellus elongate, cylindrical. Valva tapering toward apex of cucullus; apical lobe of sacculus $0.5 \times$ length of cucullus, stout, with 2 small, short, apical spines and a single, slender, moderately long, spinose lobe from base. Aedoeagus $\sim 1.38 \times$ length of valva; extruded vesica reduced, $\sim 0.75 \times$ length of aedoeagus; apex of vitta expanded (Figure 198).

FEMALE.—Unknown.

HOLOTYPE (Figure 111).—COSTA RICA: HEREDIA PROV.: Estación Biología La Selva, $10^{\circ}26'N$, $84^{\circ}01'W$, 50–150 m, σ , 3 Nov 1998, bosque secundario, L/08/501 (INBIO).

PARATYPES.—COSTA RICA: Same data as holotype, except: 1σ , 14 Jan 1999, bosque primario, L/13/542; 1σ , 2 Feb

1998, bosque primario, L/14/304; 1σ , 5 Feb 1998, L/18/309; 1σ , 9 Feb 1999, bosque secundario, L/18/567; 2σ , 25 Feb 1998, L/08/323; 2σ , 5 Mar 1998, bosque primario, L/14/324; 3σ , 8 Mar 1998, L/16/331, slide USNM 32039; 1σ , 12 Mar 1998, L/18/333; 1σ , 2 Apr 1998, L/08/347; 3σ , 15 Apr 1998, bosque primario, L/14/353; 3σ , 16 Apr 1998, L/16/355; 5σ , 20 Apr 1999, bosque secundario, L/08/621; 2σ , 21 Apr 1998, bosque primario, L/18/357; 1σ , 21 Apr 1999, bosque secundario, L/09/622, slide USNM 32288; 2σ , 22 Apr 1998, L/08/359, slide USNM 32288; 2σ , 23 Apr 1998, bosque primario, L/10/361; 1σ , 4 May 1999, bosque secundario, L/18/631, DNA sample 1320; 1σ , 5 May 1999, bosque secundario, L/08/633; 1σ , 6 May 1999, bosque primario, L/10/635; 1σ , 19 May 1998, bosque primario, L/14/377; 2σ , 20 May 1998, L/16/379; 1σ , 25 May 1999, bosque primario, L/10/647; 1σ , 27 May 1999, bosque primario, L/14/651, DNA sample 1328; 1σ , 1 Jun 1999, bosque secundario, L/16/653; 1σ , 2 Jun 1999, bosque secundario, L/18/655; 6σ , 4 Jun 1998, bosque secundario, L/16/391; 1σ , 8 Jun 1999, bosque primario, L/10/659; 1σ , 10 Jun 1999, bosque primario, L/14/633; 1σ , 11 Jun 1998, bosque primario, L/10/397; 3σ , 14 Jun 1998, bosque primario, L/14/423; 1σ , 15 Jun 1998, bosque primario, L/14/423; 2σ , 17 Jun 1998, L/14/401; 1σ , 18 Jun 1998, L/16/403; 1σ , 23 Jun 1998, L/18/405; 1σ , 14 Jun 1998, L/08/407; 2σ , 1 Jul 1998, bosque primario, L/14/411; 1σ , 21 Jul 1998, L/16/425; 2σ , 23 Jul 1998, L/08/429; 1σ , 6 Aug 1998, L/18/439; 1σ , 11 Aug 1998, bosque primario, L/08/441; 1σ , 18 Aug 1998, bosque primario, L/14/447; 1σ , 20 Aug 1998, L/18/451; 1σ , 26 Aug 1998, bosque primario, L/10/455; 1σ , 1 Sep 1998, bosque primario, L/14/459; 2σ , 2 Sep 1998, L/16/461; 1σ , 8 Sep 1998, L/08/465; 2σ , 29 Sep 1998, bosque secundario, L/08/477; 2σ , 30 Sep 1998, bosque primario, L/10/479; 1σ , 7 Oct 1998, bosque primario, L/14/483; 3σ , 22 Oct 1998, bosque primario, L/14/495, slide USNM 32036; 1σ , 27 Oct 1998, L/16/497; 1σ , 3 Nov 1998, L/08/501; 1σ , 10 Nov 1998, bosque primario, L/14/507; 1σ , 17 Nov 1998, L/08/513; 1σ , 18 Nov 1998, bosque primario, L/10/515; 1σ , 1 Dec 1998, L/08/525; 1σ , 15 Dec 1998, bosque secundario, L/18/535 (INBIO, USNM).

FLIGHT PERIOD.—Adults have been sampled throughout the year in both primary and secondary forests at La Selva, Costa Rica.

DISTRIBUTION (Map 6).—Known only from the type locality, a lowland, tropical rainforest habitat in Costa Rica.

ETYMOLOGY.—The specific name is derived from the Latin *bi* (two, double) and *lobus* (a rounded projection), in reference to the diagnostic bilobed apex of the sacculus in the male genitalia.

REMARKS.—This species was the most common arrhenophanid collected during the 18-month Microlepidoptera sampling program of the ALAS III project at the La Selva Biological Preserve, Costa Rica—the only locality where *D. bilobus* has been collected. Ninety-five males and no females were collected between 2 February 1998 and 14 January 1999, with the

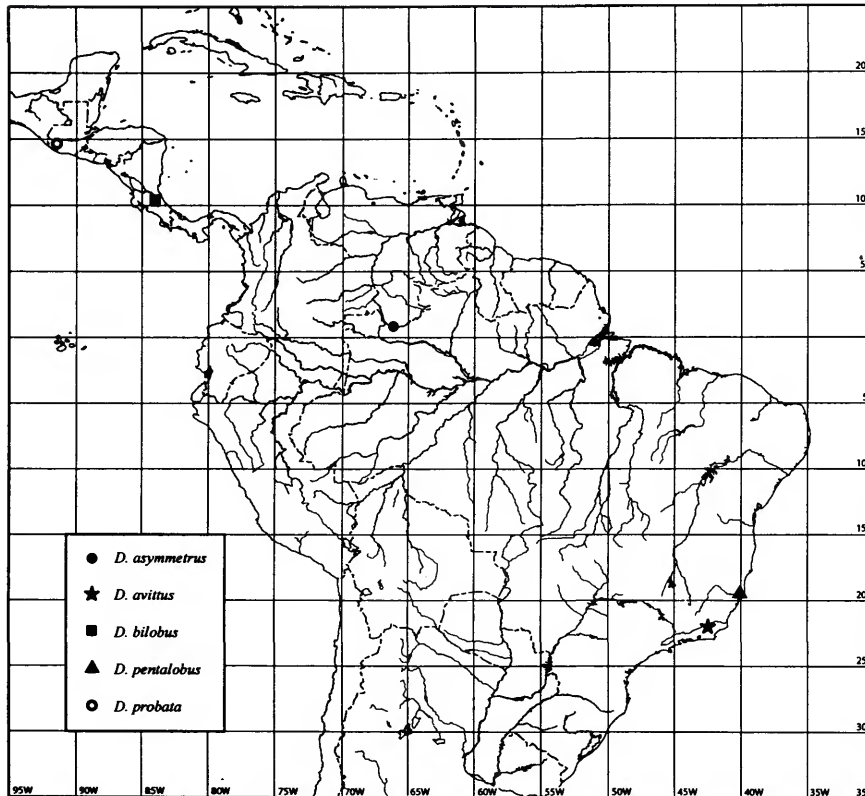

MAP 6.—Distribution of *Dysoptus asymmetricus*, *D. avittus*, *D. bilobus*, *D. pentalobus*, and *D. probata*.

months of highest collection being April (19 specimens) and June (20 specimens).

Dysoptus bilobus appears most allied to *D. pentalobus* from Brazil on the basis of both general wing color and male genital morphology. The pale yellowish spot on the termen of the forewing of *D. bilobus* is noticeably larger (Figure 111) than it is for *D. pentalobus* (Figure 112). Several features in the male genitalia distinguish these two species, including the longer, more T-shaped vinculum-saccus and the fewer secondary lobes on the saccular lobe of *D. bilobus* (Figure 197).

Dysoptus pentalobus, new species

FIGURES 112, 199–203; MAP 6

MALE (Figure 112).—Forewing length 4.8 mm.

Head: Vestiture dark brown, becoming paler brown on lower portion of frons. Antenna 32-segmented, $\sim 0.25\times$ length of forewing; scape and basal 2 flagellomeres dark brown dorsally, pale yellowish brown ventrally; remainder of flagellum uniformly pale yellowish brown. Labial palpus pale brown lat-

erally, cream to almost white mesally.

Thorax: Dark brownish fuscous dorsally, shiny cream ventrally. Forewing mostly dark brownish fuscous, with slight bluish luster, marked with pale yellow as follows: two triangular spots at basal one-third and distal one-third of costa; inner edge of spots strongly oblique and outer edge perpendicular to costal margin; a slender yellowish margin extending around wing apex and a small semicircular spot midway along termen below apex; fringe dark brownish fuscous except where suffused with yellow. Hindwing similar in color to forewing but slightly paler at base, with a streak of pale yellow across apex of discal cell at distal one-third of wing; a more basal streak partially across basal two-fifths from base of CuA2 almost to anal margin. Foreleg pale shiny yellowish brown with suffusion of dark fuscous scaling along lower (actually dorsal), outer edges of coxa, distal one-third of femur, and dorsal surfaces of tibia and first tarsomere; midleg with fuscous scaling most reduced to dorsal surfaces at apex of femur and along most of tibia; hindleg with lighter fuscous scaling along dorsal surfaces of tibia, tibial spurs, and first tarsomere.

Abdomen: Dark fuscous dorsally; sterna 2–5 cream to yellowish brown; genitalia and sterna 6–7 fuscous with slight purple luster.

Genitalia (Figures 199–203): Vinculum-saccus almost T-shaped; vinculum a narrow ventral ring; saccus slender, moderately long, approximately one-half length of valva. Apotheca reduced, approximately one-half length of saccus, and slender. Anellus triangular at ventral base and tapering to a slender membranous tube. Valva tapering to slender apex of cucullus; apex of sacculus complex, terminating in two groups of slender lobes, the basal group with three lobes and the apical group with two lobes; the more dorsal lobe of the apical set irregularly serrated at its apex. Aedoeagus (Figure 203) relatively straight for a distance of $\sim 1.2 \times$ length of valva, then abruptly turned 90° for approximately one-fourth its length; extruded vesica extending approximately three-fourths length of straight portion of aedoeagus; apex of vesica only slightly expanded.

FEMALE.—Unknown.

HOLOTYPE (Figure 112).—BRAZIL: ESPIRITO SANTO: Linhares, 40 m, 1♂, 25–30 Jan 1998, V.O. Becker, 114179, slide DRD 4101 (VOB).

FLIGHT PERIOD.—Late January (one specimen).

ETYMOLOGY.—The specific name is derived from the Greek *pente* (five) and *lobos* (a rounded projection), in reference to the complex, five-lobed, saccular apex of the valva.

DISTRIBUTION (Map 6).—Known only from the type locality in the Atlantic coastal forests of southeastern Brazil.

REMARKS.—This species is easily recognized by the complex, claw-like, saccular lobe on the male valva (Figure 201). The primary apical lobe of the sacculus is divided into five secondary lobes, some of which bear minute teeth. This character is the primary feature distinguishing *D. pentalobus* from its proposed sister species, *D. biloba*. Additional diagnoses are discussed under the latter species.

Dysoptus avittus, new species

FIGURES 113, 204–207; MAP 6

MALE (Figure 113).—Forewing length 6.0 mm.

Head: Vestiture cream. Antenna length of forewing, 30-segmented, cream dorsally; flagellum subserrate ventrally. Labial palpus cream, with brownish suffusion dorsally and laterally along segments I and II.

Thorax: Pale yellowish brown dorsally, more whitish, cream ventrally. Forewing almost uniformly pale golden to yellowish brown, with 3 or 4 pale yellow markings as follow: a small triangular spot midway along costa; an even smaller, indistinct spot at distal two-thirds of costa; a narrow, marginal band between R1–R3 above apex, and a similar but more prominent band along termen between M1–M3; fringe yellowish brown except for pale yellowish, marginal spots. Hindwing uniformly yellowish brown. Foreleg yellowish brown, with dark grayish fuscous suffusion dorsally on apex of femur, tibia,

and first tarsomere; midleg pale yellowish brown to white on much of hindleg.

Abdomen: Uniformly pale yellowish brown.

Genitalia (Figures 204–207): Vinculum-saccus Y-shaped; saccus extremely slender, elongate, $\sim 0.6 \times$ length of valva. Apotheca vestigial. Anellus cylindrical, slightly bifurcate ventrally. Valva with saccular lobe relatively short and stout, subacute. Aedoeagus with apex slightly enlarged, bearing a single, recurved, subapical spine; vesica undeveloped beyond apex of aedoeagus.

FEMALE.—Unknown.

HOLOTYPE (Figure 113).—BRAZIL: SANTA CATARINA: ♂, 26 Oct 1934, Fritz Hoffmann, slide USNM 32027 (USNM).

FLIGHT PERIOD.—October (single record).

DISTRIBUTION (Map 6).—Known only from the type locality in southern Brazil.

ETYMOLOGY.—The species name is derived from the Latin *a* (not, without), added to the male morphological structure *vitta* (ribbon, band), in reference to a principal apomorphy of this species, the absence of an extruded vesica or vitta (sensu Philpott, 1928).

REMARKS.—The saccular lobe in the male genitalia of this species is similar to that of *D. sparsimaculatus* in being moderately developed with minute, irregular lobes (Figure 206). The most diagnostic feature for the males of *D. avittus* involves specializations of the aedoeagus (Figure 207); in particular, the extreme reduction of the vitta (i.e., the extruded, nonretractable portion of the vesica) and the presence of a sharp, recurved, apical spine. The spine may be used in anchoring the aedoeagus in female tissue during copulation. An apotheca also is absent in the male genitalia (Figure 205).

Dysoptus asymmetricus, new species

FIGURES 114, 208–212; MAP 6

MALE (Figure 114).—Forewing length 4.4–4.7 mm.

Head: Vestiture uniformly pale yellowish brown. Antenna of similar color, $\sim 0.3 \times$ length of forewing, 33- or 34-segmented. Labial palpus pale yellowish brown with only slightly darker yellowish brown suffusion dorsally and laterally on segment II.

Thorax: Pale brown dorsally, cream ventrally. Forewing pale golden brown, with a distinct coppery to purplish luster near termen; a suffusion of cream along costa slightly beyond middle; fringe white before apex between R1–R3 and on termen between M1–M3, with a noticeable whitish indentation immediately below apex; remainder of fringe brown. Foreleg yellowish brown, with darker brown suffusion dorsally on apex of femur, tibia, and first tarsomere; midleg yellowish brown to cream; hindleg paler, cream to white.

Abdomen: Pale brown dorsally; paler, more yellowish brown ventrally.

Genitalia (Figures 208–212): Vinculum-saccus almost T-shaped; saccus elongate, $\sim 0.7 \times$ length of valva. Apotheca ves-

tigial. Anellus an elongate tube; apex cleft on right side. Valvae asymmetrical; apical lobe of right sacculus slender, curved, elongate, extending to apex of valva; left sacculus with lobe stouter, reduced, extending only to middle of valva. Aedoeagus with apex sharply recurved (Figure 212); vitta undeveloped beyond apex of valva.

FEMALE.—Unknown.

HOLOTYPE (Figure 114).—VENEZUELA: T.F. AMAZONAS: Cerro de la Neblina, basecamp, 0°50'N, 66°10'W, 140 m, ♂, 1–9 Feb 1987, W. Steiner, slide USNM 28504 (USNM).

PARATYPE.—VENEZUELA: Same data as holotype, except: 1♂, 1–9 Feb 1987, W. Steiner, slide USNM 28402 (USNM).

FLIGHT PERIOD.—Early February (two records).

DISTRIBUTION (Map 6).—Although known only from the type locality in southern Venezuela, this species almost certainly will be found elsewhere in the lowland rain forests of Amazonia.

ETYMOLOGY.—The specific name is derived from the Greek *asymmetros* (without symmetry), in reference to the asymmetrical valvae of the male genitalia.

REMARKS.—This species appears to be a derivative of *D. acuminatus* in that both possess elongate cucullar lobes from the male valva. In *D. asymmetrus*, however, the left lobe is reduced to less than one-half the length of the right, more sinuate lobe (Figures 210, 211). The wings, the hindwing in particular, are more uniform in color than those of *D. acuminatus* and lack the conspicuous dark bands present in the latter.

Dysoptus acuminatus, new species

FIGURES 115, 213–216; MAP 7

MALE (Figure 115).—Forewing length 5.7–6.0 mm.

Head: Vestiture off-white to pale yellowish brown. Antenna 39- or 40-segmented, $\sim 0.25 \times$ length of forewing, pale yellowish brown dorsally; flagellum subserrate ventrally; segmental lobe approximately one-half diameter of segment. Labial palpus pale yellowish brown, with dark brown scaling dorsally and laterally on segments I and II, slight brownish suffusion dorsally at base on III.

Thorax: Uniformly pale, shiny, yellowish brown. Forewing almost uniformly shiny, pale yellowish brown, except for a faint, strongly convex, slender brown band traversing basal one-third of wing (not always apparent), and a slender band of pale brown scales bordering termen; small, faint brownish clusters of scales sometimes evident at upper and lower angles of discal cell; a pale cream, triangular spot located below apex on termen spreading into mostly brown fringe; fringe at apex white. Foreleg shiny brown dorsally on coxa, femur, tibia, and most of tarsomeres, yellowish brown ventrally. Mid- and hindlegs paler, mostly pale yellowish brown.

Abdomen: Uniformly pale brown to yellowish brown.

Genitalia (Figures 213–216): Vinculum-saccus almost T-shaped; saccus elongate, more than $0.9 \times$ length of valva. Apotheca well developed, slightly longer than saccus. Anellus

a slender tube. Valva with apex of cucullus subacute; apical lobe of sacculus elongate, acute, forming a large spine. Aedoeagus more than $1.7 \times$ length of valva; vitta emerging subapically from aedoeagus, more than $3 \times$ length of aedoeagus, and with a small tubercle located near basal junction.

FEMALE.—Unknown.

HOLOTYPE (Figure 115).—VENEZUELA: T.F. AMAZONAS: Cerro de la Neblina, basecamp, 140 m, ♂, 1–9 Feb 1985, W. Steiner, slide USNM 28401 (USNM).

PARATYPE.—Same data as holotype: 1♂ (UCVM).

FLIGHT PERIOD.—February.

DISTRIBUTION (Map 7).—Although known only from the type locality in southern Venezuela, this species almost certainly will be found elsewhere in the lowland rain forests of Amazonia.

ETYMOLOGY.—The specific epithet is derived from the Latin *acuminatus* (pointed), in reference to the unique, relatively acute cucullus of the male valva.

REMARKS.—The large, spinose cucullar lobe (Figure 215) in the male genitalia of this species constitutes its most diagnostic character. In this feature it most resembles the male of *D. spilacris* from Central America. The lobe is relatively shorter and slightly stouter in *D. acuminatus*. The forewing pattern of *D. acuminatus* is more uniform than that of *D. spilacris* and lacks the characteristic apical spot present in that species.

Dysoptus spilacris, new species

FIGURES 116–118, 217–221, 246, 247; MAP 7

MALE (Figures 116, 117).—Forewing length 4.0–5.6 mm.

Head: Vestiture pale brown to cream. Antenna 32–46-segmented, $\sim 0.3 \times$ length of forewing, cream, occasionally with a few brownish scales dorsally on pedicel. Labial palpus cream, with suffusion of dark brownish fuscous scales dorsally on segments I and II.

Thorax: Light brown dorsally, with cream scales on metanotum; metanotal tuft undeveloped; shiny yellowish brown to cream ventrally. Forewing mostly pale brown marked with cream; apex of wing dull white to cream from distal one-fourth of costa diagonally across wing to middle of termen; a pale, often triangular, sometimes indistinct spot at basal one-third of costa; another, more distinct, irregular, triangular spot near apex of discal cell, usually extending to, but not reaching, a projection from costal base of apical spot; a suffusion of dark brown often present through discal cell; fringe cream around apical spot, then brown to tornus. Foreleg brown dorsally, becoming paler on distal tarsomeres; cream to yellowish brown ventrally; midleg brown dorsally on femur and tibia, cream ventrally and on tarsomeres; hindlegs cream.

Abdomen: Uniformly shiny yellowish brown to cream.

Genitalia (Figures 217–221): Vinculum-saccus almost T-shaped; saccus elongate, more than $0.8 \times$ length of valva. Tegumen with a shallow, subapical pit opening ventrally (Figure 217, SO). Apotheca undeveloped. Anellus elongate, slender,

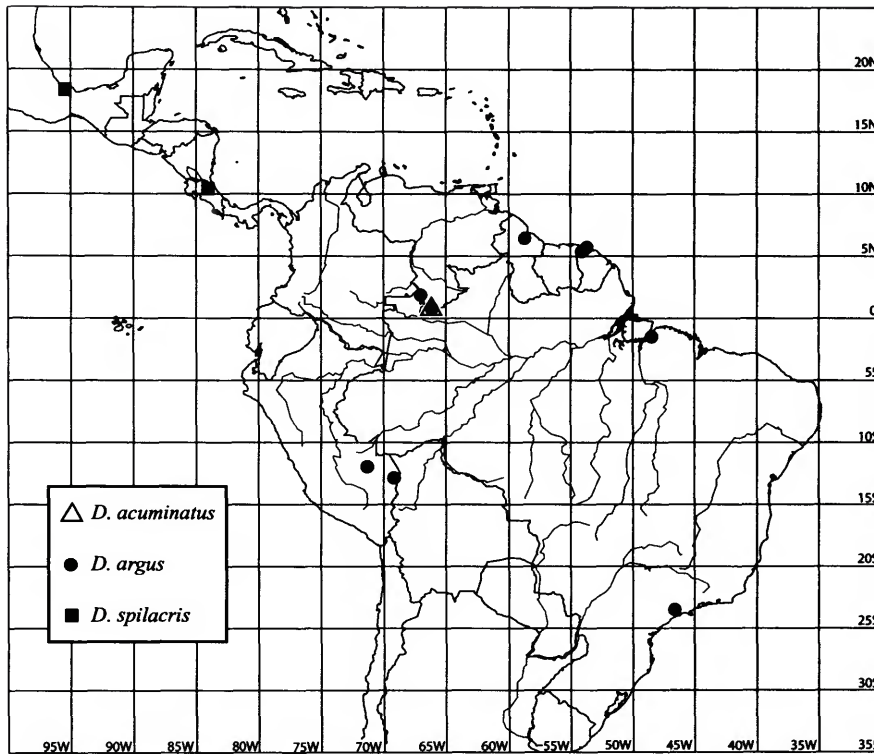

MAP 7.—Distribution of *Dysoptus acuminatus*, *D. argus*, and *D. spilacris*.

gradually tapering posteriorly. Valva with apex of cucullus moderately broad, oblique; apical lobe of sacculus greatly extended as a relatively large, curved, spinose process slightly surpassing apex of cucullus (Figure 219). Aedoeagus elongate, approximately twice length of valva; vitta variable in length because of breakage, typically greatly lengthened, from 1.5–7.0× length of aedoeagus; base of vitta slightly dilated approximately one-fifth length of aedoeagus.

FEMALE (Figure 118).—Forewing length 8.8 mm.

Genitalia (Figures 246, 247): Lamella antevaginalis with caudal margin moderately convex except for slight undulation at apex; partially free but closely associated with underlying lamella postvaginalis; caudal margin of latter truncate. Antrum extending length of eighth segment. Ductus bursae slightly dilated beyond antrum, with thickened, wrinkled walls; beyond junction of ductus spermathecae, ductus bursae a slender, membranous tube extending to small, oval corpus bursae; length of corpus approximately one-half length of anterior apophyses; entire length of ductus bursae (including antrum) almost as long as posterior apophyses. Ductus spermathecae extremely long, ~2.3× length of posterior apophyses; juncture with ductus bursae near caudal one-third of latter; slightly beyond juncture, ductus spermathecae dividing into two ducts for approximately one-fourth its length before reuniting.

HOLOTYPE (Figure 116).—COSTA RICA: HEREDIA PROV.: Estación Biología La Selva, 10°26'N, 84°01'W, 50–150 m, ♂, 24 Nov 1998, bosque primario, L/14/519 (INBIO).

PARATYPES.—COSTA RICA: Same data as holotype, except: 1♂, 20 Jan 1999, L/10/549; 1♂, 3 Feb 1999, bosque primario, L/14/563; 1♂, 23 Feb 1999, bosque primario, L/14/577, DNA sample 1329; 1♂, 3 Mar 1998, L/10/325; 1♂, 1 Apr 1998, bosque secundario, L/18/345, slide USNM 32289; 1♂, 2 Apr 1998, bosque secundario, L/08/347; 3♂, 15 Apr 1998, L/14/353; 1♂, 21 Apr 1998, bosque secundario, L/18/357; 5♂, 22 Apr 1998, bosque secundario, L/08/359, slide USNM 32061; 3♂, 23 Apr 1998, L/10/361, slide USNM 32280; 2♂, 6 May 1999, bosque primario, L/10/635; 1♂, 3 Jun 1998, L/14/389; 1♂, 3 Jun 1999, bosque secundario; 6♂, 8 Jun 1999, L/10/659; 5♂, 1♀, 10 Jun 1999, L/14/663, bosque primario, slide USNM 32189; 5♂, 17 Jun 1998, bosque secundario, L/14/401; 4♂, 24 Jun 1998, bosque secundario, L/08/407; 6♂, 25 Jun 1998, L/10/408; 2♂, 1 Jul 1998, L/14/411; 4♂, 2 Jul 1998, bosque secundario, L/16/413; 5♂, 15 Jul 1998, L/14/423; 2♂, 22 Oct 1998, L/14/495; 1♂, 4 Nov 1998, L/10/503; 1♂, 17 Nov 1998, bosque secundario, L/08/513; 1♂, 18 Nov 1998, L/10/515, slide USNM 32037; 1♂, 20 Nov 1998, 1♂, 26 Nov 1998, bosque secundario, L-18/523; 1♂, 1 Dec 1998, bosque secundario, L/08/525 (BMNH, INBIO, USNM). Estación Magsasay, 200 m, Parque Nacional Braulio Carrillo: 1♂, May 1991, A. Fernández,

slide USNM 4011 (USNM). MEXICO: VERACRUZ: Catemaco: 1♂, 7 Oct 1964, P. Spangler, slide USNM 28400 (USNM).

FLIGHT PERIOD.—Adults have been collected every month of the year except August and September at La Selva, Costa Rica.

DISTRIBUTION (Map 7).—This species occurs commonly in both primary and secondary forests at La Selva, Costa Rica. It also has been found in the adjacent Braulio Carillo National Park and in the Mexican state of Veracruz.

ETYMOLOGY.—The specific name is derived from the Greek *spilos* (spot, stain) and *akris* (tip, peak), in reference to the prominent, dull white to cream spot across the apex of the forewing.

REMARKS.—Adults of this species are easily recognized by the large whitish spot at the apex of the forewing (Figure 116), which, however, may not be apparent in worn specimens (Figures 117, 118). The valvae of the male resemble those of *D. acuminatus* in having greatly elongated, spinose saccular lobes (Figure 219). In *D. spilacris*, the apex of the cucullus is more rounded, and the saccular lobe is slightly more slender than in *D. acuminatus*. The male genitalia of *D. spilacris* are further unusual in lacking an apotheca, even though the non-retractable vitta is greatly developed and can extend up to seven times the length of the aedeagus. Instead of retaining the vitta within an apotheca, as is typically done in those arrhenophanids with greatly elongated vitta, the vitta in *D. spilacris* is held at rest in a tight coil between the closed valvae, near the apex of the aedeagus.

The most diagnostic apomorphy in the male genitalia consists of a small subapical pit (subtegumenal orifice) that opens ventrally along the tegumen (Figure 217, SO). The function of the pit is unknown, but it may be homologous to the much more elaborate, spinose pouch developed in *D. argus* (Figure 225).

After *D. biloba*, *D. spilacris* was the most common arrhenophanid encountered in the ALAS III survey at La Selva. Sixty-eight males and one female were collected between 3 March 1998 and 8 June 1999; 42% of these, including the single female, were collected in June.

Dysoptus argus, new species

FIGURES 7, 8, 16, 17, 79, 85, 86, 119, 222–226, 250, 251; MAP 7

MALE (Figure 119).—Forewing length 5.5–7.2 mm.

Head: Vestiture white, with a slight suffusion of fuscous bordering anterior margin of eye. Antenna $\sim 0.25\times$ length of forewing, 46–48-segmented, white dorsally; flagellum subseriate ventrally; segmental lobe $\sim 0.5\times$ diameter of segment in length. Labial palpus predominantly white, with black scaling dorsally and laterally on segments I and II.

Thorax (Figure 16): White, with pale grayish apices on spatulate scales from metanotal tuft. Forewing white, lightly marked with scattered, small concentrations of fuscous scales as follows: largest concentration near lower distal margin of

discal cell, with surrounding area variably suffused with scattered, pale brown to fuscous scales; 2 or 3 small, fuscous spots often present along costa, with an irregular series of 6 or 7 small fuscous spots along margin, the largest of which is located at the termination of M1; whitish scaling of discal cell distinctive, rough, often appearing greasy; fringe white. Hindwing white, less heavily marked than forewing; a small fuscous spot usually present at apex of discal cell; a series of 7–9 small fuscous marginal spots, with the largest spot near A2; fringe white. Foreleg white, with brownish suffusion dorsally on coxa, femur, tibia, and sometimes tarsomeres; mid- and hind-legs white.

Abdomen: White.

Genitalia (Figures 222–226): Vinculum-saccus Y-shaped; saccus stout, relatively short, $0.3\times$ length of valva; anterior apex clavate. Apotheca reduced, approximately equal to saccus in length. A slightly depressed, thick-walled invagination, densely lined internally with numerous small spines immediately ventrad to rectum and dorsad of apotheca; opening of pouch immediately beneath anus and subapical to a slender, dorsally grooved process projecting from midventral wall of pouch (Figure 225); length of spinose pouch $\sim 0.6\times$ that of valva. Anellus conical, apex hirsute. Valva expanding to broad, concave, distal margin; apical lobe of sacculus slender, elongate, almost as long as entire valva; apex of lobe bearing approximately 5 small dorsal teeth. Aedeagus $\sim 1.3\times$ length of valva; vitta reduced, $\sim 0.66\times$ length of aedeagus.

FEMALE.—Forewing length 10.1–12.0 mm. Antenna one-third length of forewing, 51–60-segmented (Figure 17). Body similar to male in general color pattern.

Genitalia (Figures 250, 251): Lamella antevaginalis with caudal margin strongly tapered, subacute; sterigma projecting free from eighth sternal membrane two-thirds its total length. Lamella postvaginalis undeveloped. Ostium opening on caudal apex of lamella antevaginalis. Antrum extending almost one-half length of entire ductus bursae; ductus constricted anterior to antrum and continuing as an extremely slender duct to corpus bursae; ductus seminalis relatively short, approximately one-half length of ductus bursae, and $0.3\times$ length of posterior apophysis.

PUPA (Figures 85, 86).—Length (male; dried shell) ~ 8 mm. Similar to *Arrhenophanes perspicilla* in chaetotaxy except with SV bisetose on A3–A6. Cremasteral spines minute, slightly more raised and acute than in *A. perspicilla*.

LARVAL CASE (Figure 79).—Length 11.0 mm, maximum width 3.5 mm, cylindrical; walls thick, tough, lined internally with dense, white silk, covered externally with brownish, matted silk and minute plant fragments.

HOLOTYPE (Figure 119).—VENEZUELA: T.F. AMAZONAS: Cerro de la Neblina, basecamp, 140 m, ♂, 13–20 Feb 1984, D. Davis & T. McCabe (USNM).

PARATYPES.—BRAZIL: PARA: Belém, 20 m: 2♂, 1♀, 21 Dec 1984, V.O. Becker, slides DRD 3632, 4111 (pupa), reared from *Fomes* sp. (USNM, VOB). RONDONIA: Cacaulândia, 140

m: 1♂, 1♀, Nov 1994, V.O. Becker, 80187, 96214; 1♂, 13–31 Dec 1997, V.O. Becker, 112690, slide DRD 4130 (VOB). SÃO PAULO: São Paulo, 1000 m: 1♀, 29 Jan 1993, V.O. Becker (VOB). [Locality not stated]: 1♀, 1895, E.D. Jones (BMNH). FRENCH GUIANA: SAINT LAURENT DU MARONI: Godebert-Maroni: 1♀, Jun (BMNH). Rio Maroni: 1♀, [no date], slide DRD 2144 (BMNH). St.-Jean du Maroni: 1♀, Feb (BMNH). GUYANA: MAZARUNI-POTARO: Kartabo Point: 1♂, 27 Dec 1983, W. Steiner et al. (USNM). PERU: MADRE DE DIOS: Rio Tambopata Res., 30 air km SW Puerto Maldonado, 290 m: 1♂, 2–5 Nov 1979; 2♂, 6–10 Nov 1979; 3♂, 11–15 Nov 1979; 1♂, 2♀, 16–20 Nov 1979; 1♂, 1♀, 21–25 Nov 1979, slides USNM 30548, 32281 32282, 32293, J.B. Heppner (USNM). MANU: Pakitza, 11°56'S, 71°18'W, 250 m, Trail 1 and Playa Trail: 1♂, 10–11 Sep 1989, D. Adamski & M. Epstein, MV light #8, slide USNM 32290 (USNM). VENEZUELA: T.F. AMAZONAS: Cerro de la Neblina, basecamp, 140 m: 2♂, 13–20 Feb 1984, D. Davis & T. McCabe, slide USNM 22986 (UCVM, USNM). San Carlos de Rio Negro: 2♂, 6–12 Dec 1984, R.L. Brown (USNM).

HOST.—Corioliaceae: *Fomes* sp.

FLIGHT PERIOD.—Adults have been captured in November and in February through June.

DISTRIBUTION (Map 7).—This species has been collected widely in lowland wet forests of the Amazonian Region of northern South America from southern Venezuela and Guyana to Peru and Brazil.

ETYMOLOGY.—The specific name is derived from the Greek *argus* (white), in reference to the predominantly whitish color of this species.

REMARKS.—The predominantly white wing of this species (Figure 119) easily distinguishes it from all other Arrhenophanidae except *D. pseudargus* (Figure 101). The male genitalia of *D. argus* are unique in having an unusual spinose pouch (Figure 225) whose function remains unknown. In addition, the male valva of *D. argus* differs appreciably from that of *D. pseudargus* in being much broader, with the apex of the cucullus uniquely concave.

Arrhenophanes Walsingham

Arrhenophanes Walsingham, 1913:204.—Busck, 1914:62.—Davis, 1984:25.—Nye and Fletcher, 1991:33.

TYPE SPECIES.—*Phalaena perspicilla* Stoll; by original designation.

MALE.—Length of forewing 11–21 mm.

Head (Figures 9, 10): Vestiture generally rough but with scales of lower one-half of frons more densely packed and uniformly short, with truncate to minutely bidentate apices; scales of upper frons and anterior vertex longer and more slender and partially directed down over frons; scales of upper vertex rough, mostly erect, elongate, piliform with acute apices. Eye large, interocular index 1.5. Antenna approximately two-fifths length of forewing, 55–61-segmented, shortly bipectinate to

penultimate segment (apical segment without rami); each ramus short, approximately equal in length to diameter of flagellomere, bearing numerous sensilla trichodea approximately equal in length to diameter of ramus; 3–5 compact rows of narrow, appressed scales per segment dorsally; scape rough dorsally, smooth ventrally. Haustellum essentially absent, represented by a patch of minute sensilla along mesal surface of maxilla (Figure 10). Maxillary palpus 2-segmented, segments globose, total length less than one-fourth length of basal labial palpal segment. Labial palpus 3-segmented, upcurved; vestiture smooth dorsally, moderately rough ventrally but with scales densely packed and even; apical segment noticeably depressed; ratio of segments from base: ~1:1.75:1.85.

Thorax: Forewing (Figure 37) broad, W/L index ~0.45; apex distinct; venation similar to *Dysoptus*, radius 4-branched; R2 and R3 stalked approximately one-fifth their total length; R4 and R5 fused, but with both R3 and R4+R5 terminating on termen below apex; accessory cell absent; base of M not forked within discal cell; distal one-third to one-half of discal cell appearing hyaline but covered by broad, thin, mostly erect, unpigmented, truncated scales (Figure 47); scale lamellae without fenestrae (Figure 48); scales bordering, and especially immediately basal to, hyaline area also raised (Figure 49; retinaculum similar to *Cnissostages*. Hindwing approximately as broad as forewing, L/W index ~0.55; base of M not forked within discal cell; 1A almost straight, only slightly curved; frenulum consisting of a single large bristle. Foreleg with epiphysis well developed, approximately two-thirds length of foretibia.

Abdomen: Eighth sternum with anterolateral angles projecting as short, triangular apodemes (Figure 45). Coremata absent.

Genitalia: Vinculum variable, either broad and V-shaped or a narrow, transverse band ventrally. Saccus elongate, very slender to relatively stout. Tegumen membranous, caudal margin subacute, narrowly rounded. Valva with apex of cucullus variably extended as a short lobe or an elongate, acute process; apex of sacculus terminating in a strongly bifurcate, serrate to irregularly lobed process. Vitta greatly lengthened, 1–4× length of abdomen. Apotheca well developed, almost as long as valva.

FEMALE.—Length of forewing 16–32 mm. Similar to male except antenna approximately one-third length of forewing, ~48–56-segmented, and strongly bipectinate to penultimate segment as in male; rami much longer than in male, length of longest ramus more than 5× diameter of shaft. Frenulum consisting of a cluster of approximately 9–14 smaller bristles.

Abdomen: Seventh segment relatively shortened, entirely encircled by dense cream white corethrogyne.

Genitalia: Posterior apophyses greatly lengthened, 1.6–2.5× length of anterior pair. Eighth sternum projecting caudally free from rest of segment two-thirds its length. Caudal margin of lamella antevaginalis slightly to strongly cleft. Lamella postvaginalis undeveloped. Antrum a thickened tube extending two-thirds to three-fourths length of eighth segment; beyond antrum, ductus bursae a more slender, membranous tube to reduced corpus bursae. Ductus seminalis joined to duc-

tus bursae midway along length of latter, varying greatly in length from approximately one-half to more than 3 × length of posterior apophysis.

REMARKS.—The two species of *Arrhenophanes* exhibit the greatest degree of antennal dimorphism between sexes within this family (Figures 18, 19). The maximum length of the antennal rami in the females is approximately five times the diameter of the shaft. This slightly exceeds that of female *Cnissotages mastictor*, which measures up to four times the shaft

diameter (Figure 15). The two genera differ further in venation, with that of *Arrhenophanes* having lost one radial vein as a result of the fusion of R4 and R5 (Figure 37). As discussed under the remarks for *Dysoptus*, the forewing venation of that genus and *Arrhenophanes* is considered similar in each having lost one radial vein. Their venation differs in the termination of R4 + R5 on the forewing margin, with that of *Dysoptus* being either before or at the apex (Figures 34–36), compared with a position below the apex in *Arrhenophanes* (Figure 37).

Key to the Species of *Arrhenophanes*

- Forewing discal spot with basal margin strongly oblique and with lower basal angle distinctly attenuated a short distance toward hind margin of wing [Figure 120]. Cucullus of male valva with a small process from distal margin [Figure 229] *A. perspicilla*
 Basal margin of discal spot perpendicular to costa; lower basal angle not attenuated toward hind margin [Figure 122]. Cucullus with a large, acute distal process [Figure 233] *A. volcanica*

Arrhenophanes perspicilla (Stoll)

FIGURES 9, 10, 18, 19, 37, 39, 40, 44, 45, 47–78, 82–84, 120, 121, 227–230, 252–254; MAP 8

Phalaena Bombyx perspicilla Stoll, 1790:74.

Parathyris perspicilla (Stoll).—Hübner, 1820:158, species 1641.—Busck, 1912:8.—Viereck, 1912:1.

Dasychira ? perspicilla (Stoll).—Walker, 1856:1740.

Parathyris ? perspicilla (Stoll).—Kirby, 1892:853.

Arrhenophanes perspicilla (Stoll).—Walsingham, 1913:204.—Busck, 1914:62.—Hoffmann, 1931:1.—Costa Lima, 1945:206.—Bradley, 1951:178.—Biezanko, 1961:8.—Davis, 1984:25.—Nye and Fletcher, 1991:33.

Arrhenophanes inca Meyrick, 1913:199.—Bradley, 1951:185 [synonym of *A. perspicilla*].

MALE (Figures 120, 121).—Forewing length 13–21 mm.

Head: Vestiture mostly off-white; frons more cream, moderately smooth, covered with small, short, broad scales; vertex semi-rough, scales much longer and piliform and partially directed forward over frons; occiput with lateral, piliform tufts; a short tuft of piliform scales arising ventrally between labial palpi that covers rudimentary maxillae. Antenna 55–59-segmented, approximately two-fifths length of forewing; scape with off-white vestiture dorsally, naked ventrally; flagellum shortly bipectinate almost to apex, sparsely covered dorsally with 3–5 irregular, compact rows of slender, off-white scales per segment. Labial palpus mostly pale yellowish brown to off-white, with dark fuscous dorsally on segment II and basal one-half of III.

Thorax (Figures 39, 40): Dorsal vestiture mostly similar to head in color, with a prominent tuft of grayish to fuscous, slightly banded with off-white, piliform scales arising from metanotum; ventral vestiture mostly shiny off-white, with a prominent ventral collar of fuscous beneath head. Forewing basally off-white with a predominantly dark, complex, oval pat-

tern across middle of wing that occupies more than one-half of entire forewing surface; oval area mostly dark reddish brown with a large semicircular to slightly crescent-shaped, cream-colored spot at distal one-third of discal cell; crescent spot relatively shorter, with basal margin aligned more oblique, and lower, basal angle more acute and extended caudally than in *A. volcanica*; area immediately basal to spot brownish orange; a small, linear, iridescent, pale blue patch of slender scales present in lower middle of oval area immediately anterior to CuP; distal margin of dark area often bordered by slender, sometimes faint, concentric, curved lines across wing; submarginal area from costa to tornus usually suffused with a variable amount of faint brownish scales; a small black spot on margin between M1 and M2; base of wing sometimes with brownish to grayish suffusion. Hindwing mostly off-white, with variable amount of fuscous irroration near central area of wing forming, in more well-marked specimens, a faint reticulate pattern; pattern never as distinct as in *A. volcanica*; a small black spot present near margin near apices of A1 and A2, and another, more elongate, strip of black usually evident along margin between M1 and M2. Foreleg with coxa off-white except for a small patch of brown at base; femur shiny black dorsally, off-white ventrally; tibia more brown dorsally, with a lateral brush of off-white; tarsomeres brown dorsally and basally, becoming entirely off-white more distally. Midleg mostly off-white, with slight dorsal shading of yellowish brown; hindleg uniformly off-white, rarely with a few scattered black scales.

Abdomen (Figures 44, 45): Generally off-white dorsally and ventrally, except sometimes with a suffusion of yellowish brown to pale gray dorsally beginning at A4 and widening to A8; dorsum rarely entirely pale gray.

Genitalia (Figures 227–230): Vinculum-saccus Y-shaped; saccus moderately stout, ~2 × length of vinculum. Apotheca

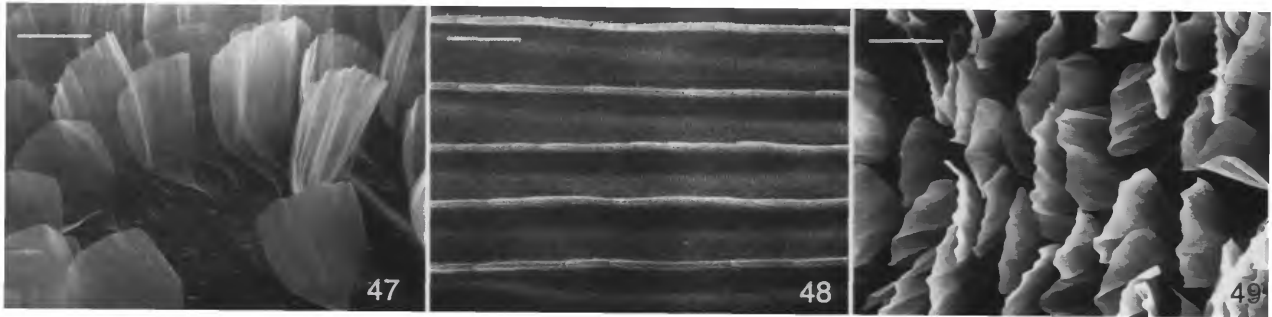

FIGURES 47–49.—*Arrhenophanes perspicilla*, forewing scale structure: 47, semi-erect scales of discal hyaline spot (100 μ m); 48, ultrastructure of hyaline scale in Figure 47 (4 μ m); 49, raised, pigmented scales immediately basad of hyaline spot (100 μ m). (Scale lengths in parentheses.)

enlarged, exceeding length of saccus by almost one-third its length. Caudal apex of anellus moderately broad. Valva with apical lobe of sacculus terminating in a prominent chelate process bearing serrations along inner margins (Figure 229); apex of cucullus terminating in a short, slender process. Aedoeagus almost as long as valva, with a greatly extended vitta more than $24\times$ length of aedoeagus and more than $7\times$ length of entire body.

FEMALE.—Forewing length 19–32 mm. Color pattern similar to male. Antenna approximately one-half length of forewing, 48–56-segmented, bipectinate almost to apex; longest rami $\sim 5\times$ diameter of shaft in length, relatively broad, flat.

Abdomen: Corethropygne present, consisting of a dense encirclement of long, off-white to pale gray, piliform scales from A7.

Genitalia (Figures 252–254): Lamella antevaginalis deeply cleft. Antrum well developed, forming a slender, sclerotized tube $\sim 0.75\times$ length of anterior apophysis; anterior two-thirds of ductus bursae greatly constricted to a slender, membranous tube. Ductus seminalis extremely elongated, more than $3\times$ length of posterior apophysis, joining ductus bursae near middle of latter. Corpus bursae moderately reduced. Ductus spermathecae short, less than one-half length of spermathecal sac.

EGG (Figures 50–52).—Maximum length 0.87 mm, width 0.56 mm. All surfaces generally smooth except for reticular micropyle area composed of 25–35 irregular cells bounded by low ridges (Figures 51, 52).

LARVA (Figures 53–77).—Length of largest larva 41 mm, maximum width 10 mm. Cuticle white, with yellowish brown to black plates and spots.

Head: Yellowish brown. Ecdysial line extending $\sim 0.8\times$ distance to epicranial notch; frontoclypeus almost two-thirds the distance to epicranial notch. Seta AF1 absent. P1 arising close to ecdysial line slightly above middle of frons; P2 absent. F1 arising adjacent to lateral adfrontal suture. Six stemmata present. SS1 situated well forward of fifth stemmata. Antenna (Figures 65, 66) 3-segmented, with long tactile sensillum and 2

short, basiconic sensilla from second segment; segment 3 with one basiconic sensillum of similar size to previous pair, one very small tuberculate sensillum basiconica, and a sensillum styloconicum (sometimes considered a fourth segment) bearing a similarly small tubercle. Maxilla as in Figures 71, 72; mesal lobe with a pair of moderately large sensilla styloconica and 3 minute sensilla basiconica; sensilla trichodea highly irregular, deeply divided or branched so as to seemingly exceed the typical number (3). Labrum with all 6 pairs of dorsal setae present; deeply emarginate anteriorly. Mandible black with two setae; 1 acute and 4 or 5 less distinct, more truncate cusps. Hypopharynx densely setose dorsally (Figure 70). Labial palpus slender, elongate; first (basal) segment $\sim 3\times$ length of second (apical), the latter bearing a single long sensillum as long as the segment (Figure 69). Spinneret long and gradually tapering to a slender, simple apex (Figure 68).

Thorax: Notal plates and pinnacula yellowish brown to black; pronotum with 6 black marginal spots anteriorly and 2 black lines posteriorly; mesonotum broadly edged on all sides with black except along pale medial line; metanotum reduced, with 2 black spots dorsally, the larger of which has a yellow center. Prothoracic spiracle oval with longitudinal axis oriented vertically; spiracle with a densely spinose filtering system (Figures 75, 76) consisting of several clusters of approximately 20–25 spines each; peritreme thickened, raised. Lateral series trisetose; L1 on separate pinnaculum from L2 and L3 on T2–T3. SV series bisetose. Legs well developed, with a stout, slightly curved claw (Figures 73, 74).

Abdomen: Pinnacula brown. D1 and D2 arising from separate pinnacula except on A9–A10 where they are joined. L3 on separate pinnaculum from L1–L2 on A1–A7. SV trisetose on A1, A3–A6, bisetose on A2 and A7. A8 with spiracle on same pinnaculum with L1. Spiracles similar in size and structure as on prothorax. Crochets approximately 13–19 on A3–A6; anal crochets 14–17.

LARVAL CASE (Figure 78).—Largest case 40 mm long, 16 mm wide, slightly depressed; walls thick, tough, lined inter-

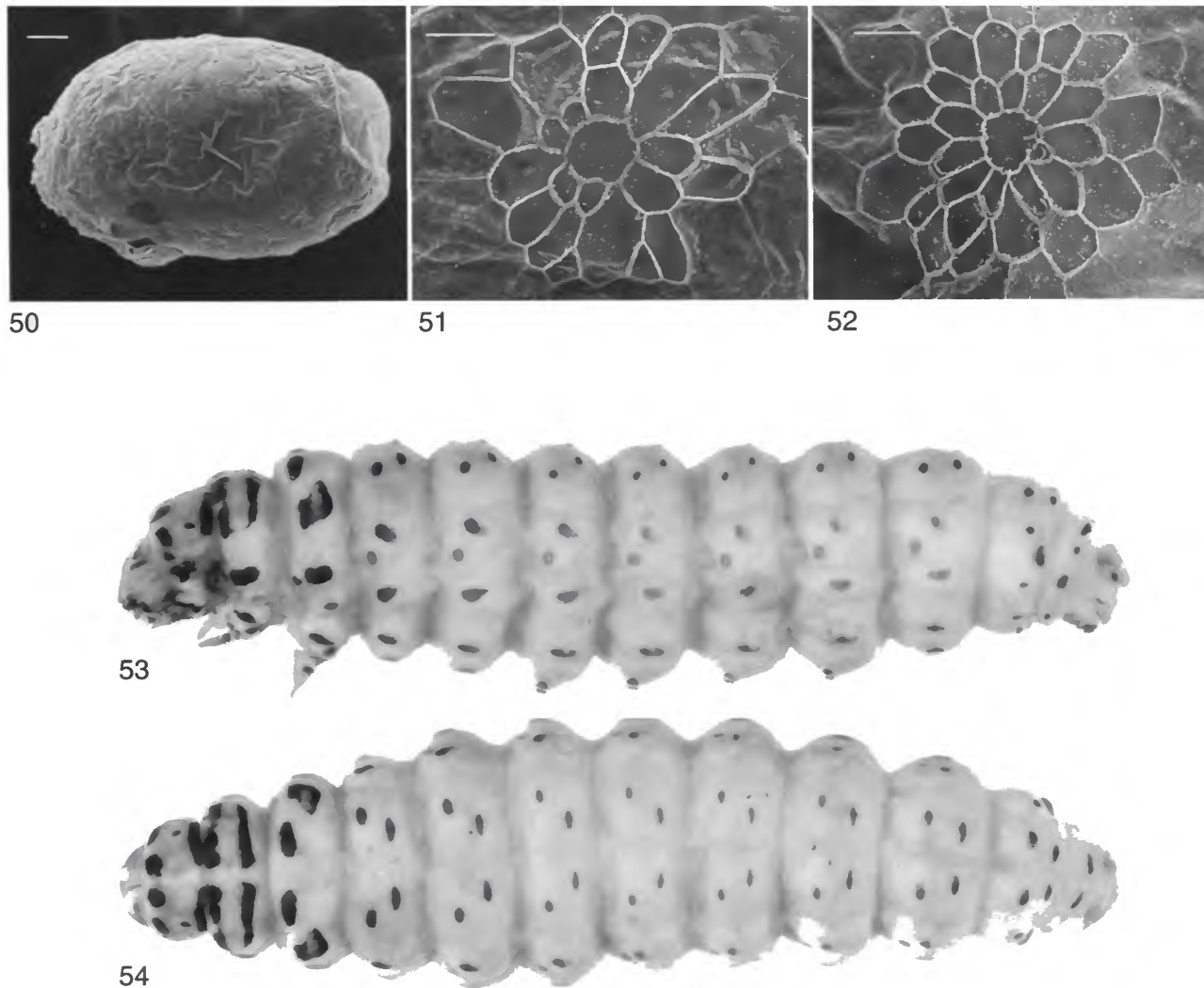

FIGURES 50-54.—Egg and late instar larva of *Arrhenophanes perspicilla*: Egg structure: 50, egg (200 μ m); 51, micropyle area (30 μ m); 52, micropyle area (30 μ m). Larva: 53, lateral view; 54, dorsal view, length 41 mm. (Scale lengths in parentheses.)

nally with dense, white silk, covered externally with brownish, matted silk and fungal fragments.

PUPA (Figures 82-84).—Maximum length 22 mm (♀) and 17 mm (♂). Female antennal sheaths more than 2 \times width of those of male. Pronotum and mesonotum with 2 pairs of dorsal setae; caudal pair more approximate; caudal pair on mesonotum adjacent to pronotal suture. Terga 3-5 with 2 pairs of dorsal setae; A1-A2, A6-A10 with single pair. A single row of tergal spines present on A3-A7 of female and A3-A8 of male; those on A3 less well developed. SV unisetose on A3-A7.

HOLOTYPE [?].—(*Arrhenophanes perspicilla* (Stoll)); **SURINAM**: ♀, deposition unknown.

(*Arrhenophanes inca* Meyrick); **PERU**: JUNIN: El Porvenir, 3000 ft [914 m], ♀, 1908 (BMNH).

HOST.—Polyporaceae: *Polyporus* sp. (Busck, 1912); *Polyporus guaraniticus* Speg.; *Polyporus vulgaris* L. (Biezan-ko, 1961).

PARASITOID.—Ichneumonidae: *Sesioctonus parathyridis* Viereck

FLIGHT PERIOD.—In favorable habitats, adults of this species can be encountered throughout the year. In the lowlands of Costa Rica, for example, adults have been collected in every month of the year.

DISTRIBUTION (Map 8).—This species occurs throughout much of the lowland Neotropical Region from the state of Veracruz in Mexico to Misiones in Argentina and Rio Grande do Sul in southern Brazil; absent from the West Indies.

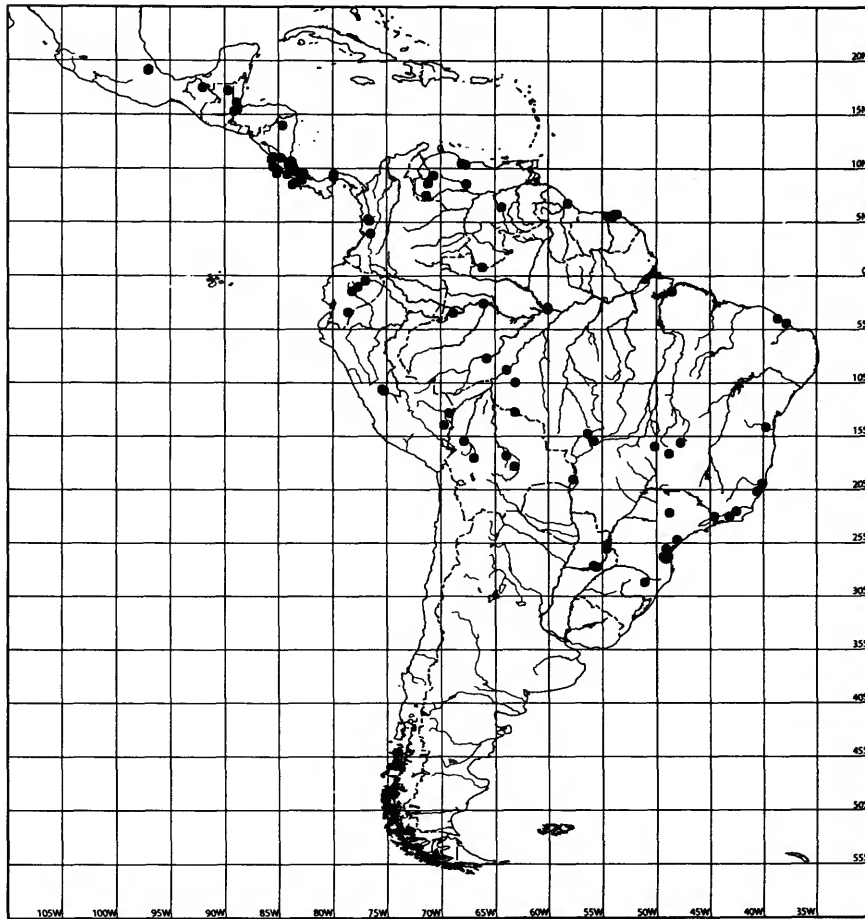
MAP 8.—Distribution of *Arrhenophanes perspicilla*.

MATERIAL EXAMINED.—ARGENTINA: MISIONES: Haut Paraná, San Ignacio de Misiones: 1 ♀ [no date] (BMNH). BELIZE: Punta Gorda: 2 ♂, Jun 1933; 1 ♂, Jun 1933; 1 ♂, Jul 1934, J. White (BMNH). BOLIVIA: COCHABAMBA: Chapare, Alto Palmer, 1100 m: 1 ♂, Jun 1913 (CNC). SANTA CRUZ: “Provincia del Sara”: 1 ♀, Jul 1913; 1 ♀, Nov 1912, Steinbach (CMNH). Rio Songo, 750 m: 1 ♂, [no date], Fassl (USNM). Santa Cruz: 1 ♂, Oct, Steinbach (BMNH). BRAZIL: ALAGOAS: Maceió: 1 ♀, [no date] (BMNH). AMAZONAS: Canadian Fathers’ Pool, 2 km N of Manaus, Itacoatiara Hwy: 1 ♂, 11 May 1972, E.G. & E.A. Munroe (CNC). Fonte Boa: 2 ♂, Jul 1906, Kluges (BMNH). Manaus: 1 ♀, 12 Feb 1896, Austen (BMNH). Manaus, Reserva Ducke, km 26, Itacoatiara Hwy: 1 ♂, 15 May 1972; 1 ♂, 19 May 1972, E.G. & E.A. Munroe (CNC). Manaus, Reserva Ducke, km 26, Itacoatiara Hwy, Plateau Hut: 1 ♂, 1 ♀, 13 Dec 1993, J.V. Sullivan & R.W. Hutchings (USNM). Reserva Duque, 50 km NW Manaus: 1 ♂, 1 ♀, 5 Dec 1974, K. Sandved (USNM). Rio Purus, Hyutanaha: 4 ♂, Jan 1922; 9 ♀ Feb 1922; 1 ♂, 1 ♀, Mar 1922, S.M. Klages (CMNH). Rio Purus, Miracena: 1 ♀, Apr 1922, S.M. Klages (CMNH). Rio Purus, Nova Olinda: 16 ♂, May 1922; 2 ♂, Jun 1922, S.M. Klages

(CMNH). São Paulo de Olivença: 1 ♀, Dec 1931, Wucherpfennig (BMNH); 2 ♂, 1 ♀, Nov–Dec, Fassl (USNM). BAHIA: Ipiáú, 150 m: 1 ♂, 20 Jan 1967, V.O. Becker (VOB). CEARÁ: Pacatuba, 250 m: 1 ♀, 6 Apr 1994, V.O. Becker, 91707 (VOB). DISTRITO FEDERAL: Planantina, 15°35’S, 47°42’W, 1000 m: 2 ♂, 8 Feb 1976; 1 ♂, 28 Apr 1976, V.O. Becker, 19557 (VOB); 1 ♂, 8 Mar 1999, DNA sample 1330, V.O. Becker (USNM). ESPIRITU SANTO: Linhares, 40 m: 1 ♂, 5–9 Apr 1992; 3 ♂, 20–29 Feb 1992; 1 ♂, 1 ♀, 16–18 Sep 1991, V.O. Becker, Nos. 80830, 81914, 82902 (VOB). GOIAS: Goiás, 500 m: 1 ♂, 13–15 Oct 1984, V.O. Becker, 52228 (VOB). Leopoldo de Bulhoes: 5 ♂, 1 ♀, Dec 1935, R. Spitz (BMNH). St. Leopoldina, Dorf Tirol, 600 m: 2 ♂, 1–29 Jan 1999; 1 ♂, 1–30 Jan 2000; 1 ♀, 15 Oct 1997; 1 ♂, 1–31 Dec 1999, H. Thöny (USNM). MATO GROSSO: Chapada dos Guimarães, 800 m: 2 ♂, 25–30 Nov 1997, V.O. Becker, 111057 (VOB). Nobres, 600 m: 1 ♂, 25 Oct 1993, V.O. Becker (VOB). MATO GROSSO DO SUL: Corumbá, 180 m: 2 ♂, 23–25 Apr 1985, V.O. Becker, 64002 (VOB). PARA: Belém: 1 ♂, [no date], M. Moss (BMNH). PARANA: Foz do Iguaçú: 1 ♀, 28 Jan 1971, Laroca & Jensen (VOB). RIO DE JANEIRO: Campo Bella: 1 ♂, 25 Jan 1927 (USNM). Cachoeira do Macacu, 700

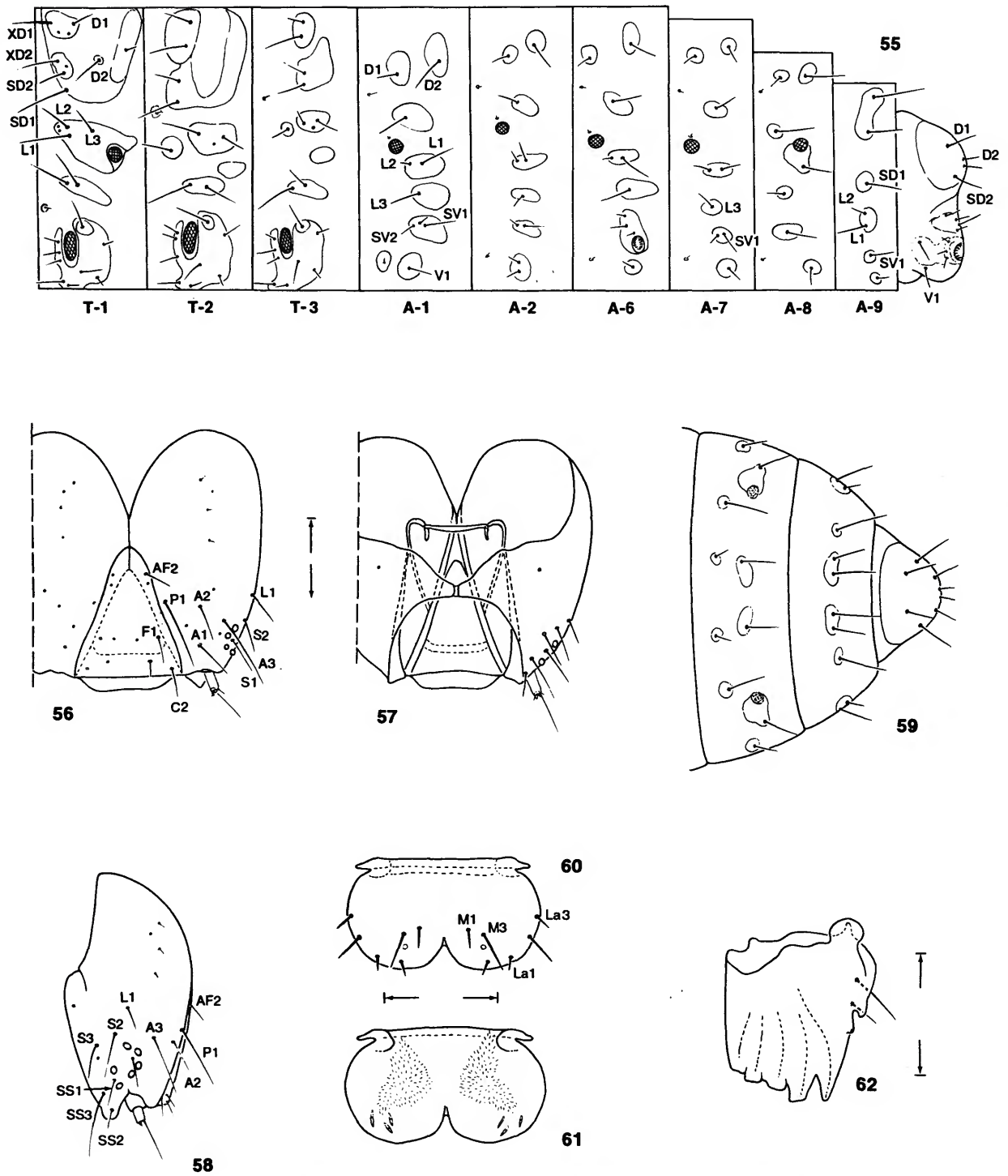

FIGURES 55-62.—*Arrhenophanes perspicilla*, chaetotaxy of late instar larva: 55, lateral schematic of prothorax, mesothorax, metathorax, and abdominal segments 1, 2, 6-10; 56, head, dorsal view (1 mm); 57, ventral view; 58, lateral view; 59, dorsal view of abdominal segments 8-10; 60, labrum, dorsal view (0.5 mm); 61, ventral view; 62, mandible (0.5 mm). (Scale lengths in parentheses.)



FIGURES 63–74.—*Arrhenophanes perspicilla*, late instar larva: 63, head, lateral view (0.5 mm); 64, stemmata (150 μ m); 65, antenna (120 μ m); 66, terminal detail of Figure 65 (38 μ m); 67, head, ventral view (0.43 mm); 68, spinneret, ventral view (150 μ m); 69, hypopharynx and labial palpi, dorsal view (0.27 mm); 70, hypopharynx, dorsal view (100 μ m); 71, right maxilla, ventral view (136 μ m); 72, mesal lobe, ventral view (40 μ m); 73, prothoracic leg (0.3 mm); 74, pretarsal claw (75 μ m). (Scale lengths in parentheses; bar scale for all photographs shown in Figure 63.)

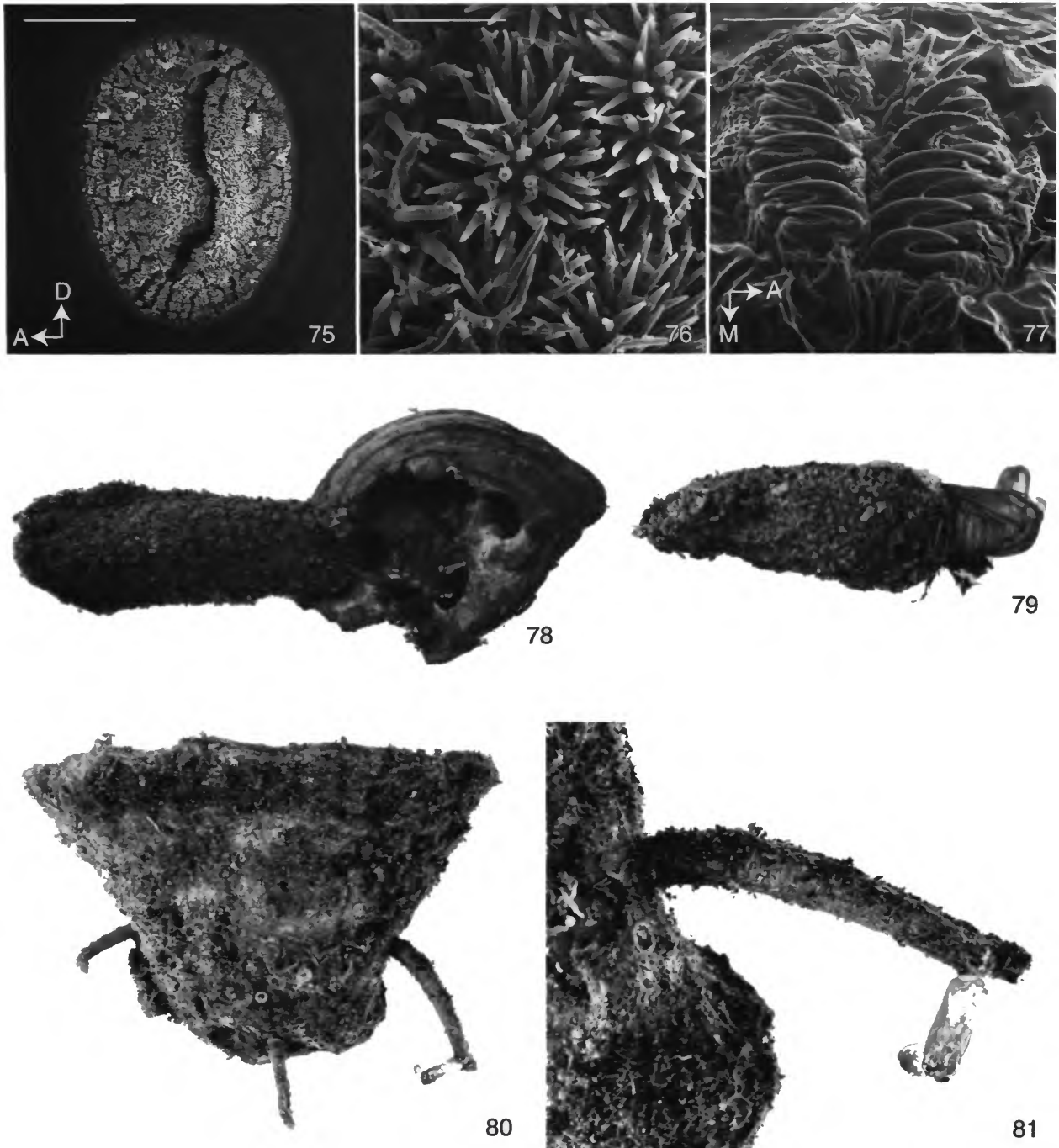

FIGURES 75–81.—Larva and larval cases. *Arrhenophanes perspicilla*: 75, prothoracic spiracle of larva (86 μ m); 76, detail of spiracular filter spines in Figure 75 (86 μ m); 77, larval crochets of fourth abdominal segment (86 μ m); 78, larval case (length 40 mm) attached to host fungus (*Polyporus* sp.). *Dysoptus argus*: 79, larval case (length=11 mm). *Dysoptus prolatus*: 80, larval cases attached to ventral surfaces of host fungus (*Phyllinus gilvus*; width of upper surface of fungus 6 cm); 81, larval case (length 16.5 mm). (A=anterior, D=dorsal, M=mesal). (Scale lengths in parentheses.)

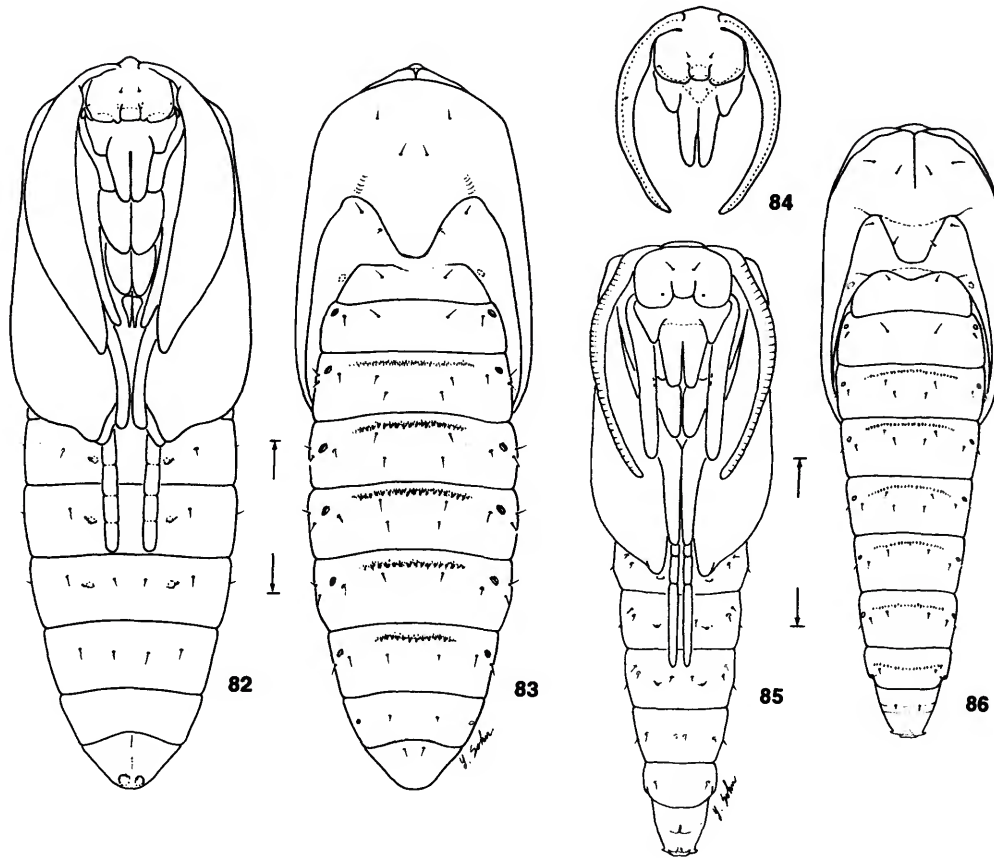

FIGURES 82–86.—Pupae. *Arrhenophanes perspicilla*: 82, female, ventral view (5.0 mm); 83, dorsal view; 84, male pupal head capsule. *Dysoptus argus*: 85, male pupa, ventral view (2.0 mm); 86, dorsal view. (Scale lengths in parentheses.)

m: 1♂, 23 Jan 1998, V.O. Becker, 113401 (VOB). Garcíe: 1♂, 25 May 1955, H. Ebert (USNM). Petrópolis, 650 m: 1♂, 10–20 Oct 1985, V.O. Becker (VOB). [locality not stated]: 1♂, [no date], G.G. MacBean; 1♂, 1 Jan 1932; 1♂, 28 Jan 1927; 1♂, 14 Feb 1929, J.F. Zikan (USNM). RIO GRANDE DO SUL: Hamburgo Velho: 1♂, 1♀, 21 Nov 1920, Schwarz (BMNH). RONDONIA: Ariquemes, 180 m: 1♀, 13–15 Apr 1989, V.O. Becker, 61806 (VOB). Cacaúlândia, 140 m: 1♂, 13–31 Dec 1997, V.O. Becker, 112689 (VOB). Porto Velho, 180 m: 3♂, 24 Apr–12 May 1989, V.O. Becker, 76308 (VOB). Vilhena, 600 m: 1♀, 10–13 Apr 1996, V.O. Becker, 107136 (VOB). SANTA CATARINA: Blumenau: 1♂, [no date], E. Wenzel (MNHU). Corupá: 1♂, Feb 1956, E.G. Munroe; 1♀, Dec 1954, A. Mather (CMNH). Jaraguá do Sul: 1♂, Oct 1935, Hoffmann (BMNH). Joinville: 1♀, [no date], Arp (USNM). New Bremen: 1♂, 1 May 1931, F. Hoffman (CU). Rio Vermelho, São Bento do Sul, 850 m: 1♂, 24 Jan 1974, Rank, 11063 (VOB). [locality not stated]: “St. Catharina”: 1♂, [no date]; 1♀, [no date], slide AB

822 (USNM). SÃO PAULO: Est. Boracéia, near Salesópolis, 850 m: 1♂, 13 Mar 1972, E.G. & E.A. Munroe (CNC). Jacupiranga, 800 m: 1♂, 8 Feb 1993, V.O. Becker, 87529 (VOB). COLOMBIA: CHOCO: Chigorodó: 1♀, 8 Mar 1974, A. Lopez, 74-7350 (USNM). Condoto: 1♂, [no date], Spurrell (BMNH). VALLE DEL CAUCA: Bajo Calima, CCHq, 300 ft [91 m]: 1♂, 11 Jan 1985, J.B. Sullivan (USNM). COSTA RICA: ALAJUELA: NE slope of Volcan Poas, 8 km N. Vava Blanca, 1400 m: 1♂, 19 Jun 1988, Brown and Powell, BL [blacklight] (UCB). PIAYUELES, 20–50 m: 1♂, 29 Mar 1996, K. Flores (INBIO). CARTAGO: Cachi: 1♀, 1915 (BMNH). Juan Viñas: 1♂, [no date] (USNM). Quebrada Segunda, Parque Nacional Tapantí, Area Conservación Amistad, 1500 m: 2♂, Jul 1994, G. Mora (INBIO). Tuis: 1♂, 28 May–4 Jun (USNM). Turrialba, 600 m: 1♂, 10 Feb 1973; 1♂, 20 Apr 1973; 1♂, 15 Jul 1971; 1♂, 20 Aug 1971; 1♂, 10 Oct 1971; 1♂, 25 Oct 1971; 1♂, 25 Nov 1972, V.O. Becker, Nos. 26061, 26024, 26029, 26030, 26039, 26040, 26043 (VOB); 1♂, 15 Dec 1974, K. Sandved (USNM); 2♂, [no

date] (USNM). GUANACASTE: La Emilia: 1♂, 16 Nov 1909, P.P. Calvert (CMNH). Nicoya, W Carmona: 1♂, 19 Aug 1982, Janzen & Hallwachs (USNM). Pitilla: 1♂, 2000, V.O. Becker, USNM DNA Bank Lep DRD #63 (USNM). 2 km SW Santa Cecilia: 1♂, 25 Dec 1984, Janzen & Hallwachs (USNM). Santa Rosa National Park: 1♀, 1–8 Aug 1980; 1♂, 15–17 Dec 1979, D. Janzen (INBIO). HEREDIA: Estación Magsasay, Braulio Carrillo, 200 m: 1♂, May 1991, R. Aguilar (INBIO). La Selva Biological Station, Puerto Viejo de Sarapiquí, 40 m: 1♂, 26 Dec 1986–8 Jan 1987, M. Chavarría (INBIO); 1♂, 27 Jun–6 Jul 1994, J. Powell (UCB). LIMON: Amubri, A.C. Amistad, 70 m: 1♂, 10–31 Oct 1995; 2♂, 4–21 Dec 1993, G. Gallardo (INBIO). Cerro Tortuguero, Parque Nacional Tortuguero, 100 m: 1♂, Apr 1989; 1♂, Dec 1989, J. Solano (INBIO). Estación Cuatro Esquinas, Parque Nacional Tortuguero, 0 m: 1♂, Jul 1990, F. Quesada (INBIO). Estación Hitoy-Cerere, R. Cerere, Reserva Biológica Hitoy, 160 m: 1♂, Jul 1991, A. Moreno (INBIO). La Florida, 500 ft [153 m]: 1♂, [no date], slide AB (USNM). Sector Cerro Cocori, Finca de E. Rojas, 150 m: 4♂, Apr 1991; 2♂, Aug 1991; 1♂, Oct 1991, E. Rojas (INBIO). Sixola River: 1♂, [no date] (USNM). PUNTARENAS: Estación Esquinas, Península de Osa, 0 m: 1♂, Jan 1993, F. Quesada (INBIO). Estación Esquinas, Area Conservación Osa, Península de Osa, 200 m: 1♂, Jan 1993, M. Segura (INBIO). Estación Quebrada Bonita, 100 m: 1♂, Sep 1995, R. Guzmán (INBIO). Estación San Miguel, Reserva Natural Cabo Blanco: 1♂, Sep 1993, M. Ramírez. Send. El Mirador, 100 m: 1♂, 29 Sep–1 Oct 1997, F. Alvarado (INBIO). Estación Sirena, Parque Nacional Corcovado, Area Conservación Osa, 1–100 m: 2♂, Jan 1990; 1♂, Jan 1991; 2♂, Feb 1990; 1♂, Feb 1993; 1♂, Mar 1991; 2♂, May 1993; 1♂, Jul 1992; 1♂, 27 Aug–4 Sep 1989; 2♂, Sep 1989; 1♂, Nov 1993; 1♂, Dec 1989, G. Fonseca (INBIO). Finca Cafrosa, Estación las Mellizas, Parque Nacional La Amistad, 1300 m: 1♀, Oct 1989, M. Ramirez (INBIO). Quepos, Manuel Antonio National Park, 80 m: 1♀, Feb 1993; 1♂, Mar 1993; 1♂, Oct 1992, G. Varela (INBIO); 1♂, Jun 1987, A. Chacón (INBIO). Quepos, Parque Nacional Manuel Antonio, 120 m: 2♂, Dec 1990, G. Varela & R. Zuñiga (INBIO). Rancho Quemado, Península de Osa: 1♂, Feb 1991; 1♂, Nov 1990, F. Quesada; 1♂, Mar 1991, J.C. Sabario (INBIO). ECUADOR: ESMERALDAS: Mayronga, 20 km SE Laygarto, 100 m: 1♂, 20 Nov 1993, G. Onore (CMNH). Hacienda La Mascota, Rio Topo, 4500 ft [1373 m]: 1♂, 20 Apr 1931, W.J. Coxey (CMNH). MORONA-SANTIAGO: Gualaquiza, 900 m: 1♂, 19 Dec 1992, 102409 (VOB). NAPO: 210 m: 1♂, 11 Mar 1986, McKamey (UCB). Mishualli, 450 m: 2♂, Dec 1992, V.O. Becker, 102171 (VOB). FRENCH GUIANA: SAINT LAURENT DU MARONI: Mana River: 1♂, May 1917 (CMNH). R. Maroni: 1♂, 1915; 2♂, 1♀, 1916, Le Moulton (BMNH). Saint-Jean, Maroni: 1♀, Aug?, Le Moulton (BMNH), 1♂, 2♀, [no date] (USNM); Saint-Jean, R. Maroni: 1♂, 1915, Le Moulton (BMNH). Saint-Jean du Maroni: 7♂, 3♀, [no date], Le Moulton (BMNH); 2♂, [no date] (USNM). GUATEMALA: IZABAL: Cayuga: 4♂, 1♀, [no date], W. Schaus, slide AB

(USNM); 1♂, Aug, Schaus & Barnes (USNM); 3♂, [no date], Schaus & Barnes (USNM). Quiriguá: 1♂, Mar; 1♂, May, Schaus & Barnes (USNM). PETEN: Tical, 200 m: 1♂, 10 May 1969, S. Steinhauser (USNM). [locality not stated]: 1♂, [no date], Schaus (USNM). GUYANA: EAST DEMERARA-WEST COAST BERBICE: Mackenzie, Demerara River: 1♂, 22 Jun 1927, lot 760, subplot 104 (CU). MEXICO: CHIAPAS: Palenque: 1♂, 13 Jan 1974, R. Lavigne, M 164 (USNM). Yaxoquintela, 560 m: 1♂, 20 Aug 1978; 1♂, 24 Aug 1978; 1♂, 10 Sep 1978; 1♂, 21 Sep 1978, J.E. Rawlins (CMNH). VERACRUZ: 5 km S. Coscomotepec: 1♀, 8 Jun 1991, J.A. Chemsak, at light (UCB). Huatusco, 1300 m: 1♂, 19–21 Aug 1981, V.O. Becker (VOB). NICARAGUA: Eden: 1♂, 25 Mar 1922; 1♂, 28 May 1922, W. Huber (CMNH). PANAMA: Cabima: 1♂, May 1911, em: 17 Jan 1912, ex *Polyporus*, A. Busck (USNM) [em=emerged]. CANAL ZONE: Barro Colorado: 1♂, 21 Oct, M. Bates (CMNH). Barro Colorado Island: 1♀, 30 Jun 1978, Silberghied & Aiello (USNM). Coco Solo: 4♂, 2♀, 1946–1947, R.E. Ludwig (CAS). Paraiso: 1♂, 1911, A. Busck, [adult in pupal exuvia] (USNM). Rodman: 1♀, 25 Jan 1958, W.P. Thomas (CMNH). Tabernilla: 1♂, [no date], A. Busck (USNM). PARAGUAY: ITAPUA: Trinidad: 1♀, 18 Dec 1920, C. Jorgensen (USNM). [locality not stated]: 1♀, Jun, G.G. MacBean (USNM). PERU: JUNIN: El Porvenir, 3000 ft [914 m]: 1♀, 1908, "P," Holotype: *inca* Meyr" (BMNH). MADRE DE DIOS: Osherato, Río Tambo: 2 larvae, case, collected on šitovikini, USDA lot 80-8076 (USNM). Rio Tambopata Res., 30 air km SW Puerto Maldonado, 290 m: 2♀, 2–5 Nov 1979; 1♂, 3♀ 6–10 Nov 1979, slides USNM 23625, 23626, 22961, 22962; 3♂, 1♀, 11–15 Nov 1979, J.B. Heppner (USNM). PASCO?: Oxacampa: 1♀, [no date], 2094 (CU). PUNO: La Oroya, R. Ianambari, 3100 ft [946 m]: 1♂, Jul 1904, Ockenden (BMNH). PROV.?: Jaupl Bajo: 1♀, Oct 1962, L. Harris (BMNH). SURINAM: MAROWINE: Moengo, Boven-Cottica River: 8♂, 22–27 May 1927, CU lot 760, subplot 71-81 (CU). TRINIDAD: Arima Valley, Simla: 1♂, 22 Mar 1981, M[ercury] V[apor], M.J.W. Cock, USNM. VENEZUELA: ARAGUA: Rancho Grande, 1100 m: 1♂, 22–30 Feb 1967, R.W. Poole (USNM). BARINAS: Rio Caparo Research Station: 1♂, 3–5 Feb 1978, J.[B.] Heppner (BMNH). Rio Caparo Res. Station, 32 km E Canton: 7♂, 2♀, 3–5 Feb 1978, J.B. Heppner (USNM). CARABOBO: Las Guiguas, San Esteban: 1♀, [no date], Kluges (BMNH). GUARICO: Hato Masaguaral, 45 km S Calabozo, 75 m: 1♂, 1♀, 22 Jun 1989; 1♂, 24–26 Jun 1989, M. Epstein & M. Rodriguez; 3♀, 3–5 Jun 1988, M. Epstein (USNM). Hato Flores Morales, 45 km S Calabozo, 75 m: 2♂, 5–7 Jul 1989, M. Epstein & M. Deza (USNM). MERIDA: Mérida: 1♂, 2♀, [no date], Briceno (BMNH). 1♂, 1♀, [no date] (USNM). T.F. AMAZONAS: Cerro de la Neblina, basecamp, 140 m: 8♂, 1♀, 4–12 Feb 1984, slide USNM 23624; 2♂, 1♀, 1–10 Mar 1984, D.R. Davis & T. McCabe; 1♀, 18 Feb 1985, R. Faitout & W. Steiner (USNM). TRUJILLO: Valera: 1♂, [no date], E.P. de Bellard (USNM). [locality not stated]: 3♂, [no date] (CMNH).

REMARKS.—*Arrhenophanes perspicilla* is the largest, most

spectacular member of this small family. Consequently, it has been the most widely collected species by nonspecialists. Records exist from 11 of the 13 South American countries and from six Central American countries. It is also the only arrhenophanid species for which larvae were available for study. Two other species, *Dysoptus argus* and *D. prolatus*, have been reared, but no larval specimens were preserved. Larval feeding and case construction were first reported by Busck (1912), and this has been summarized in the "Introduction" herein.

The wing patterns of *Arrhenophanes perspicilla* and its sister species, *A. volcanica*, are similar enough for these insects to be occasionally confused, particularly in the case of worn specimens. The large, pale, forewing discal spot in *A. perspicilla* is diagnostic in having a strongly oblique basal margin that continues as a small indentation toward the hind margin (Figure 120). In *A. volcanica*, the basal margin of the discal spot is not oblique, and there is no indentation at the lower basal angle of the spot (Figure 122). The male valvae of the two species can be easily distinguished (Figures 229, 233).

The vesica of male *A. perspicilla* is the most developed of any species of Lepidoptera and may reach lengths exceeding seven times the length of the entire body. This is several times the length of the vesica in *A. volcanica*, a difference also reflected in the relative length of the ductus seminalis in their respective females (Figures 252, 255).

Arrhenophanes volcanica Walsingham

FIGURES 122–124, 231–234, 255; MAP 9

Arrhenophanes volcanica Walsingham, 1913:206.—Davis, 1984:25

MALE (Figures 122, 123).—Forewing length 11–16 mm.

Head: Vestiture similar to *A. perspicilla*, mostly off-white, frons more cream. Antenna 58–61-segmented, approximately two-fifths length of forewing; scape and flagellum similar to *A. perspicilla*. Labial palpus similar to *A. perspicilla* but with dark fuscous scaling barely extending onto dorsum of segment III.

Thorax: Similar to *A. perspicilla*. Forewing pattern closely resembling that of *A. perspicilla* except with large discal cream spot more semicircular, with basal margin more parallel to body, and without extended basal-caudal angle. Hindwing similar to that of *A. perspicilla* but pattern much more distinct, with irregular, alternating bands of off-white and brown; small black spots located at outer margin near M1–M2 and A2. Legs similar in color pattern to *A. perspicilla*.

Abdomen (Figure 124): Similar to *A. perspicilla* in color.

Genitalia (Figures 231–234): Vinculum-saccus T-shaped; vinculum a narrow ventral band; saccus very slender, with swollen anterior end, $\sim 3 \times$ length of vinculum. Apotheca enlarged, more than $2 \times$ length of saccus. Caudal apex of anellus very slender. Valva with apical lobe irregularly furcate, each fork terminating in 3 or 4 irregularly curved teeth (Figure 233); apex of cucullus bifurcate, ventral fork noticeably longer. Ae-

doeagus extremely slender, elongate, $\sim 0.8 \times$ length of valva; vitta more than $2 \times$ length of aedeagus.

FEMALE.—Forewing length 16–22 mm. Antenna approximately one-third length of forewing, 48–50-segmented, scape and flagellum similar to *A. perspicilla*. Color pattern similar to male.

Abdomen: Similar to that of *A. perspicilla*.

Genitalia (Figure 255): Lamella vaginalis with caudal margin sinuate, not deeply cleft. Antrum well developed, noticeably stouter than that of *A. perspicilla*, almost $0.75 \times$ length of anterior apophysis; anterior two-thirds of ductus bursae greatly constricted to a slender, membranous tube. Ductus seminalis normal, only slightly longer than anterior apophysis, joining ductus bursae near middle of latter. Corpus bursae and spermatheca similar to that of *A. perspicilla*.

TYPE.—Lectotype σ (present designation); GUATEMALA: QUEZALTENANGO: Cerro Zunil, 4000–5000 ft [1220–1524 m] (BMNH). Throughout his treatment of the Heterocera in volume 4 of the *Biologia Centrali-Americana*, Walsingham consistently selected both a "type" male and "type" female, whenever both sexes were present in the series before him. Any additional specimens were considered "PT" (paratype). To insure that only one specimen represents the type of this species, I have selected the male "type" as lectotype.

FLIGHT PERIOD.—Over its broad range, adults of this species have been collected throughout the year. Likewise in Costa Rica, adults are recorded from almost every month.

DISTRIBUTION (Map 9).—The geographical range of this species is similar to that of *A. perspicilla*, being found in much of the lowland Neotropical Region, from the Mexican state of Veracruz to Rio Grande do Sul in southern Brazil; it is absent from the West Indies.

MATERIAL EXAMINED.—BRAZIL: AMAZONAS: Fonte Boa: 1 σ , May 1906, M. de Matham (BMNH). Manaus, Reserva Ducke, km 26 Itacoatiara Hwy: 1 σ , Apr 1972; 1 σ , 20 Apr 1972, E.G. & E.A. Munroe (CNC). Pebas: 1 σ , Nov 1906, M. de Matham (BMNH). Rio Purus, Hyutanaha: 1 σ , Mar 1922, S.M. Kluges (CMNH), Rio Purus, Miracena: 1 σ , Apr 1922, S.M. Kluges (CMNH). ESPÍRITO SANTO: Linhares, 40 m: 1 σ , 16–18 Sep 1991, V.O. Becker, 80830 (VOB). MATO GROSSO DO SUL: Corumbá, 600 m: 1 σ , 20–22 Apr 1985, V.O. Becker (VOB). PARÁ: Marabá, 50 m: 1 σ , 9 Jan 1977, V.O. Becker (VOB). RIO GRANDE DO SUL: Hamburgo Velho: 3 σ , 21 Nov 1920, Schwarz (BMNH). RONDONIA: Cacauiândia, 140 m: 1 σ , Dec 1991, V.O. Becker, 80186 (VOB). Porto Velho: 1 σ , Feb–Mar 1926, A. Moss (BMNH); 189 m: 1 σ , 24 Apr–12 May 1989, V.O. Becker, 76308 (USNM). SANTA CATARINA: Rio Laeiss, Nova Bremen: 2 σ , Jan 1932 (BMNH). [locality not stated]: 1 σ , [no date] (BMNH); 1 σ , Coll. Staudinger (MNHU). "Sta. Catherine": 1 σ , [no date] (USNM). SÃO PAULO: São Paulo: 1 σ , [no date], H. von Hering (USNM). COLOMBIA: CHOCO: Chigorodó: 1 σ , 27 Feb 1974, A. Lopez, 74-7350, ex *Polyporus* (USNM). El Tigre, Rio Tamana, Rio San Juan: 3 σ , Feb 1909, Palmer (BMNH). VALLE DEL CAUCA: Bajo Calima, C.C.HQ.,

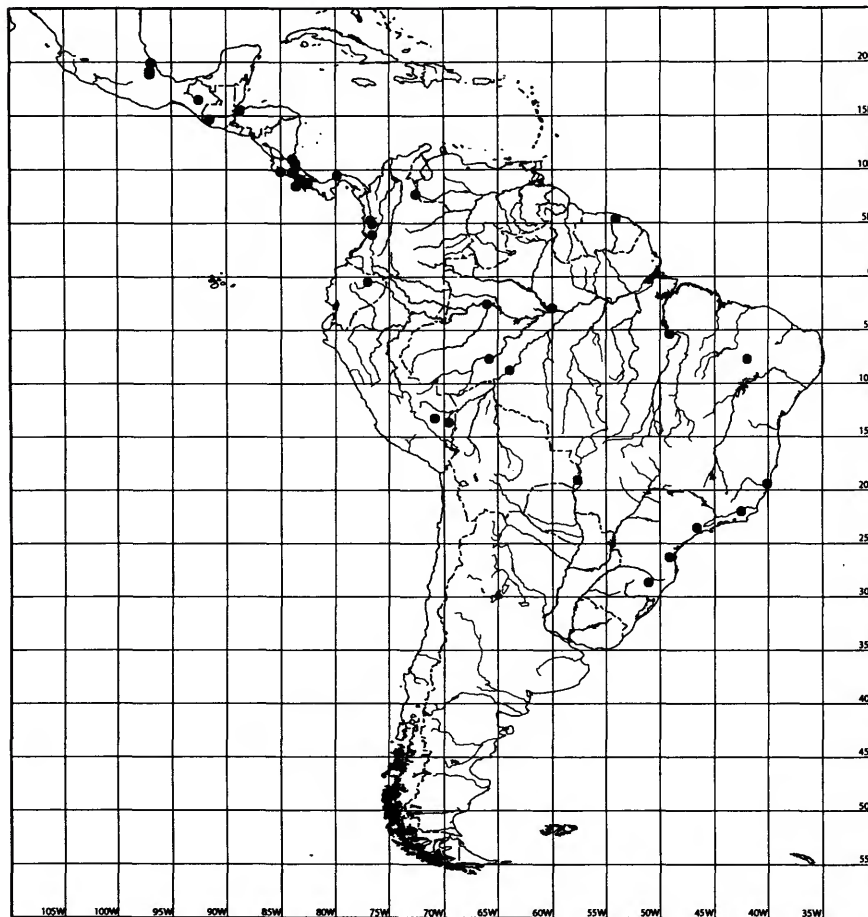

MAP 9.—Distribution of *Arrhenophanes volcanica*.

300 ft [92 m]: 1♂, 19 Jan 1988, J.B. Sullivan (USNM). COSTA RICA: CARTAGO: 3 km S Casa Mata, 16 km S San Isidro de Tejar, 1800 m: 1♂, 4 Dec 1983, Janzen & Hallwachs (USNM). CACHI: 2♂, Oct 1912, Lankester (BMNH); 1♂, [no date] (USNM). LIMON: Sector Cerro Cocori, Finca de E. Rojas, 150 m: 1♂, Apr 1991; 1♂, Jul 1991, E. Rojas (INBIO). PUNTARENAS: Buenos Aires, La Amistad, Sector Altamira: 1♂, 21 Feb–10 Mar 1984; 1♂, Nov 1993; 1♂, Dec 1993, R. Delgado (INBIO). Estación Esquinas, Península de Osa, Area Conservación Osa, 200 m: 1♂, Jul 1993, M. Segura (INBIO). Estación Quebrada Bonita, Reserva Biológica Carará, 50 m: 2♂, Jun 1991; 1♂, 1♀, Sep 1989; 1♂, Oct 1989; 1♂, Nov 1989, R. Zuñiga (INBIO). Estación Sirena, Parque Nacional Corcovado, 0–100 m: 1♂, Feb 1990; 1♂, Mar 1991; 1♂, May 1991; 1♂, Oct 1989; 1♂, Nov 1991; 3♂, Nov 1989, G. Fonseca (INBIO). SAN JOSE: Estación Carrillo, Parque Nacional Braulio Carrillo, 700 m: 1♂, May 1985, I. & A. Chacón (DHJ). PROVINCE.?: [locality not stated]: 1♂, [no date] (BMNH). ECUADOR: Dos Puentes, Kil. 99, 1700 ft [519 m]: 1♀, Jan 1929, W.J. Cokey (CMNH). NAPO: Mishualli Jungle Hotel, on Napo River, 1200 ft [366 m]:

1♂, 7–19 Sep 1997, R. Leuschner (UCB). FRENCH GUIANA: SAINT LAURENT DU MARONI: St.-Jean, Maroni: 1♂, [no date] (USNM). GUATEMALA: IZABAL: Cayuga: 1♂, Jan 1917; 1♂, Jan 1918, Schaus & Barnes (USNM). QUEZALTENANGO: Cerro Zunil, 4000–5000 ft [1220–1524 m]: 1♂, Aug–Sep 1880, G. Champion, “Type ♂” (BMNH). MEXICO: CHIAPAS: [locality not stated]: 1♂, [no date], C. Hoffman (USNM). VERACRUZ: Cordoba: 1♂, 6 Jul 1966, J. Buckett, M. & R. Gardner (UCB). Huatusco, 1300 m: 1♂, 19–23 Aug 1981, V.O. Becker, 44056 (VOB). Misantla: 1♂, [no date], Guglemann (BMNH); 1♀, Jul 1911, R. Muller, slide USNM 28472 (USNM). NICARAGUA: [locality not stated]: 1♂, 22 Dec 1927 (USNM). PANAMA: CANAL ZONE: Barro Colorado Island: 1♂, 16 Mar 1979, Silberglied & Aiello (USNM). CHIRIQUI: Volcan Chiriquí, 2000–3000 ft [610–914 m]: 1♂ (paralectotype), 1881, Champion, “Type ♀” (BMNH). PERU: CUZCO: Quincemil, 780 m: 1♂, 15–20 Oct 1962, L. Peña (CNC). PUNO: La Unión, Río Huacamayo, Carabaya: 2♀, [no date], Ockenden (BMNH). VENEZUELA: TACHIRA: 14 km E. Rubio: 1♂, 24 Feb 1978, J.B. Heppner, slide USNM 23627 (USNM).

REMARKS.—Although superficially resembling *A. perspicilla* in wing pattern and sometimes in overall size, this almost equally widely collected species can be distinguished by several characters summarized in the key to species and discussed

further under *A. perspicilla*. Additional differences include the generally more rounded apex of the forewing and more distinctly marked hindwing of *A. volcanica* as compared with *A. perspicilla*.

Literature Cited

- Becker, V.O.
1984. Taxonomic Notes on the Neotropical Microlepidoptera. *Revista Brasileira de Entomologia*, 28(2):129–201.
- Biezanko, C.M.
1961. XIII: Olethreutidae, Tortricidae, Yponomeutidae, Gelechiidae, Oecophoridae, Xylorictidae, Cecidoseidae, Acrolophidae, Tineidae, Psychidae, et Arrhenophanidae da Zona Missioneira do Rio Grande do Sul. *Arquivos de Entomologia*, series B, pages 1–8, Ministério da Agricultura.
- Bradley, J.D.
1951. Notes on the Family Arrhenophanidae (Lepidoptera: Heteroneura), with Special Reference to the Morphology of the Genitalia, and Descriptions of One New Genus and Two New Species. *The Entomologist*, 84(1059):178–185.
- Busck, A.
1912. Descriptions of New Genera and Species of Microlepidoptera from Panama. *Smithsonian Miscellaneous Collections*, 59(40):1–10, plate 1.
1914. New Genera and Species of Microlepidoptera from Panama. *Proceedings of the United States National Museum*, 47:1–67.
- Carter, D.J., and J.S. Dugdale
1982. Notes on Collecting and Rearing *Micropterix* (Lepidoptera: Micropterigidae) Larvae in England. *Entomology Gazette*, 33:43–47.
- Clarke, J.F. Gates
1955–1970. *Catalogue of the Type Specimens of Microlepidoptera in the British Museum (Natural History) Described by Edward Meyrick*. 1:i–viii, 1–332, plates 1–4 (1955); 2:1–531, plates 1–263 (1955); 3:1–600, plates 1–298 (1958); 4:1–521, plates 1–252 (1963); 5:1–581, plates 1–283 (1965a); 6:1–581, plates 1–283 (1965b); 7: 261, plates 1–60 (1970).
- Corrales, J.F., and M.E. Epstein
1997. Review of the Costa Rican *Venadicodia*, with Descriptions of Two New Species and Localities for *V. rutha* (Lepidoptera: Limacodidae). *Revista de Biología Tropical*, 45(3):1093–1105.
- Costa Lima, A. Da
1945. Lepidópteros. In *Insetos do Brasil*, 5(1):1–379. Escola Nacional de Agronomia, Série Didática, No. 7.
- Davis, D.R.
1964. Bagworm Moths of the Western Hemisphere (Lepidoptera: Psychidae). *United States National Museum Bulletin*, 244:1–233, 385 figures.
1975. Two New Species of Bagworm Moths from Venezuela with Special Remarks on Reproductive Morphology in Psychidae (Lepidoptera: Psychidae). *Proceedings of the Entomological Society of Washington*, 77(1):66–77.
1984. Neopseustidae, Nepticulidae, Opostegidae, Tischeriidae, Incurvariidae, Cecidosidae, Adelidae, Prodoxidae, Tineidae, Psychidae, Arrhenophanidae. In J.B. Heppner, editor, *Atlas of Neotropical Lepidoptera*, checklist, part 1, pages 16–25. The Hague: Dr. W. Junk.
1986. A New Family of Monotrysiian Moths from Austral South America (Lepidoptera: Palaephatidae), with a Phylogenetic Review of the Monotrysiia. *Smithsonian Contributions to Zoology*, 434: 202 pages, 599 figures, 15 maps, 2 tables.
1987. Micropterigidae, Eriocraniidae, Acanthopteroctetidae, Nepticulidae, Opostegidae, Tischeriidae, Heliozelidae, Adelidae, Incurvariidae, Prodoxidae, Tineidae, Psychidae, Ochsenheimeriidae, Lyonetiidae, Gracillariidae, Epipyropidae. In F.W. Stehr, editor, *Immature Insects*. pages 341–378, 456, 459–460. Dubuque, Iowa: Kendall/Hunt Publ. Co.
1990. Three New Species of *Acrolophus* from the Southeastern United States with Remarks on the Status of the Family Acrolophidae (Lepidoptera: Tineoidea). *Proceedings of the Entomological Society of Washington*, 92(4):694–704.
1991. First Old World Record of the Moth Family Arrhenophanidae (Lepidoptera: Tineoidea). *Tropical Lepidoptera*, 2(1):41–42.
1992. Arrhenophanidae. In J.B. Heppner and H. Inoue, editors, *Lepidoptera of Taiwan*, volume 1, part 2: checklist, page 65. Gainesville, Florida: Association for Tropical Lepidoptera.
1998a. A World Classification of the Harmacloninae, a New Subfamily of Tineidae (Lepidoptera: Tineoidea). *Smithsonian Contributions to Zoology*, 597:1–81, 345 figures, 8 maps.
1998b. A Revision of the Genus *Lamyristis* Meyrick (Lepidoptera: Psychidae) and Proposal of a New Related Genus *Acoremata* from Southeast Asia. *Proceedings of the Entomological Society of Washington*, 100(1):114–125.
2000a. Tineoidea and Gracillarioidea (Lepidoptera). In J.E. Llorente Bousquets, E. González Soriano, and N. Papavero, editors, *Biodiversidad, Taxonomía y Biogeografía de Artrópodos de México: Hacia una Síntesis de su Conocimiento*, 2:469–482. Mexico, DF: Bayer.
2000b. *Brachygyna incaea*, a New Genus and Species of Psychidae from Peru with Atypical Larval Biology (Lepidoptera: Tineoidea). *Tropical Lepidoptera*, 10(2):51–58.
- Davis, D.R., D.H. Clayton, D.H. Janzen, and A.P. Brooke
1986. Neotropical Tineidae, II: Biological Notes and Descriptions of Two New Moths Phoretic on Spiny Pocket Mice in Costa Rica (Lepidoptera: Tineoidea). *Proceedings of the Entomological Society of Washington*, 88(1):98–109.
- Davis, D.R., and E.G. Milstrey
1988. Description and Biology of *Acrolophus pholeter* (Lepidoptera: Tineoidea), a New Moth Commensal from Gopher Tortoise Burrows in Florida. *Proceedings of the Entomological Society of Washington*, 90(2):164–178.
- Davis, D.R., and G.S. Robinson
1998. The Tineoidea and Gracillarioidea. In N.P. Kristensen, editor, *Lepidoptera, Moths and Butterflies. Handbuch der Zoologie, IV (Arthropoda): Insects*, 35:91–117. Berlin and New York: Walter de Gruyter & Co.
- Dyar, H.G.
1927. New Species of American Lepidoptera of the Families Limacodidae and Dalceridae. *Journal of the Washington Academy of Science*, 17(21):544–551.
- Fletcher, T.B.
1929. A List of the Generic Names Used for Microlepidoptera. *Memoirs of the Department of Agriculture in India, Entomological Series*, 11: i–ix, 1–244.
- Goloboff, P.A.
1993. *NONA. Version 2.0*. [Computer program and documentation. Available from J. Carpenter, Department of Entomology, American Museum of Natural History, New York, New York, 10024-5192, USA.]
- Grey, Thomas de (see Walsingham, Lord)
- Hättenschwiler, P.
1985. Psychidae. In J. Heath, editor, *The Moths and Butterflies of Great Britain and Ireland*. Volume 2: Cossidae—Heliodinidae, pages 128–151. Oxford: Blackwell Scientific Ltd., and London: The Curwen Press.
1998. Neue *Eumasia* Arten aus Mittelspanien und den Malediven und einige Ergänzungen zur Kenntnis der Gattung *Eumasia* (Psychidae). *Nota lepid.*, 21(4):264–282.

- Heath, J.
1976. Micropterigidae. In J. Heath, editor, *The Moths and Butterflies of Great Britain and Ireland*. Volume 1: Micropterigidae–Heliozelidae, pages 151–155. Oxford: Blackwell Scientific Ltd., and London: The Curwen Press.
- Hoffmann, F.
1931. Beiträge zur Naturgeschichte brasilianischer Schmetterlinge, II. Sonderabdruck aus der "Zeitschrift für Wissenschaftliche Insektenbiologie," 26(1):1–8.
- Hübner, J.
1816–1826. *Verzeichniss bekannter Schmetterlinge*. 71 [abstract] + 431 pages. Augsburg.
- Kirby, W.F.
1892. *A Synonymic Catalogue of Lepidoptera Heterocera*. Volume 1:i–xii, 1–951. London: Gurney and Jackson.
- Kristensen, N.P.
1998. The Non-Glossatan Moths. In N.P. Kristensen, editor, *Lepidoptera, Moths and Butterflies. Handbuch der Zoologie, IV (Arthropoda): Insects*, 35:41–49. Berlin and New York: Walter de Gruyter & Co.
- Lorenz, R.E.
1961. Biologie und Morphologie von *Micropteryx* [sic] *cathella* (L.). *Deutsche Entomologische Zeitschrift*, 8:1–23.
- Meyrick, E.
1913. Descriptions of South American Microlepidoptera. *Transactions of the Entomological Society of London*, 1913:170–200.
1919. *Exotic Microlepidoptera*. Volume 2(8–9):225–288. London: Taylor & Francis
- Nixon, K.C.
1999a. *Winclada (BETA) version 0.9.9*. Ithaca, N.Y.: Published by the author.
1999b. The Parsimony Ratchet, a New Method for Rapid Parsimony Analysis. *Cladistics*, 15(4):407–414.
- Nye, I.W.B., and D.S. Fletcher
1991. The Generic Names of Moths of the World. *Microlepidoptera*, 6:1–368. London: Natural History Museum Publications.
- Paynter, R.A., Jr., and M.A. Taylor
1981. *Ornithological Gazetteer of Colombia*. 311 pages. Cambridge, Massachusetts: Museum of Comparative Zoology, Harvard University.
- Philpott, A.
1928. The Male Genitalia of the New Zealand Carposinidae. *Transactions and Proceedings of the New Zealand Institute*, 59(3):476–477.
- Powell, J.A.
1980. Evolution of Larval Food Preferences in Microlepidoptera. *Annual Review of Entomology*, 25:133–159.
- Powell, J.A., C. Mitter, and B. Farrell
1998. Evolution of Larval Food Preferences in Lepidoptera. In N.P. Kristensen, editor, *Lepidoptera, Moths and Butterflies. Handbuch der Zoologie, IV (Arthropoda): Insects*, 35:403–422. Berlin and New York: Walter de Gruyter & Co.
- Rawlins, J.E.
1984. Mycophagy in Lepidoptera. In Q. Wheeler and M. Blackwell, editors, *Fungus-Insect Relationships, Prospectives in Ecology and Evolution*, pages 382–423. New York: Columbia University Press.
- Robinson, G.S.
1986. Fungus Moths: A Review of the Scardiinae (Lepidoptera: Tineidae). *Bulletin of the British Museum (Natural History), Entomology Series*, 52(2):37–181.
1988. A Phylogeny for the Tineoidea. *Entomologica Scandinavica*, 19(2): 117–129.
- Robinson, G.S., and E.S. Nielsen
1993. Tineid Genera of Australia (Lepidoptera). *Monographs on Australian Lepidoptera*, 2: xvi, 1–344. Melbourne: CSIRO.
- Sanford, R.L., Jr., P. Paaby, J.C. Luvall, and E. Phillips
1994. Climate, Geomorphology, and Aquatic Systems, In L.A. McDade, K.S. Bawa, H.A. Hespenheide, and G.S. Hartshorn, editors, *La Selva, Ecology and Natural History of a Tropical Rain Forest*, pages 19–33. Chicago and London: The University of Chicago Press.
- Sauter, W., and P. Hattenschwiler
1991. Zum System der palaearktischen Psychiden, 1: Liste der palaearktischen Arten. *Nota Lepidopterologica*, 14(1):69–89.
- Stoll, C.
1791. *Supplément à l'ouvrage, Intitule les papillons exotiques, des trois parties du monde l'Asie, l'Afrique et l'Amerique; par Mr. Pierre Cramer*. vii + 181 pages. Amsterdam: chez Nic. Th. Gravius.
- Tillyard, R.J.
1926. *The Insects of Australia and New Zealand*. xi + 560 pages. Sydney, Australia: Angus & Robertson, Ltd.
- Tuxen, S.L., editor
1956. *Taxonomist's Glossary of Genitalia in Insects*. 284 pages. Copenhagen: Ejnar Munksgaard.
- Viereck, H.L.
1912. New Genus and Species of Hymenoptera of the Family Braconidae from Panama. *Smithsonian Miscellaneous Collections*, 59(5):1–2. (Publication 2080.)
- Walker, F.
1856. *List of the Specimens of Lepidopterous Insects in the Collection of the British Museum*. Part 7, pages 1509–1808.
- Walsingham, Lord (Thomas de Grey)
1909–1915. *Lepidoptera-Heterocera*. In F.D. Godman and O. Salvin, *Biologia Centrali-Americana*, 4(42): xii + 482 pages, 10 plates.
- Zeller, P.C.
1863. Zwölf amerikanische Nachtfalter. *Entomologische Zeitung*, 24(4–6): 136–155.

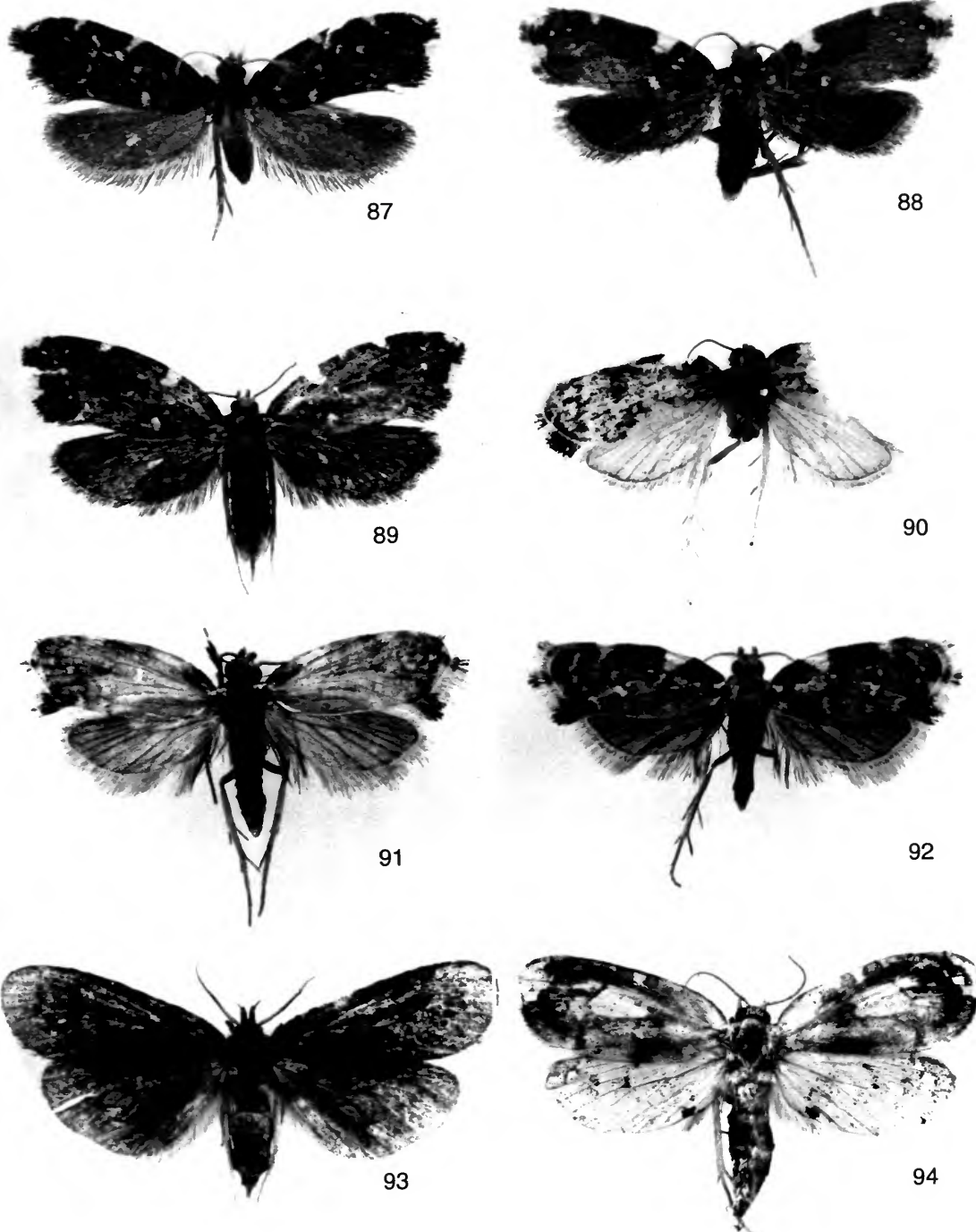

FIGURES 87-94.—Adults. *Palaeophanes lativalva*: 87, holotype male, Fennchihwu, Taiwan (4.9 mm). *Palaeophanes taiwanensis*: 88, holotype male, Liukuei Forest Station, Taiwan (5.8 mm); 89, female (9.0 mm). *Palaeophanes* sp.: 90, male, Gunong Monkobo, Sabah, Malaysia (6.5 mm). *Palaeophanes brevispina*: 91, holotype male, Ulu Temburong, Brunei (6.0 mm). *Palaeophanes xoutha*: 92, holotype male, Western Pahang, Malaysia (6.0 mm). *Notiophanes fuscata*: 93, holotype female, Atherton, Qld., Australia (27.0 mm). *Cnissostages oleagina*: 94, male, São Joaquim, Brazil (13.1 mm). (Forewing lengths in parentheses.)

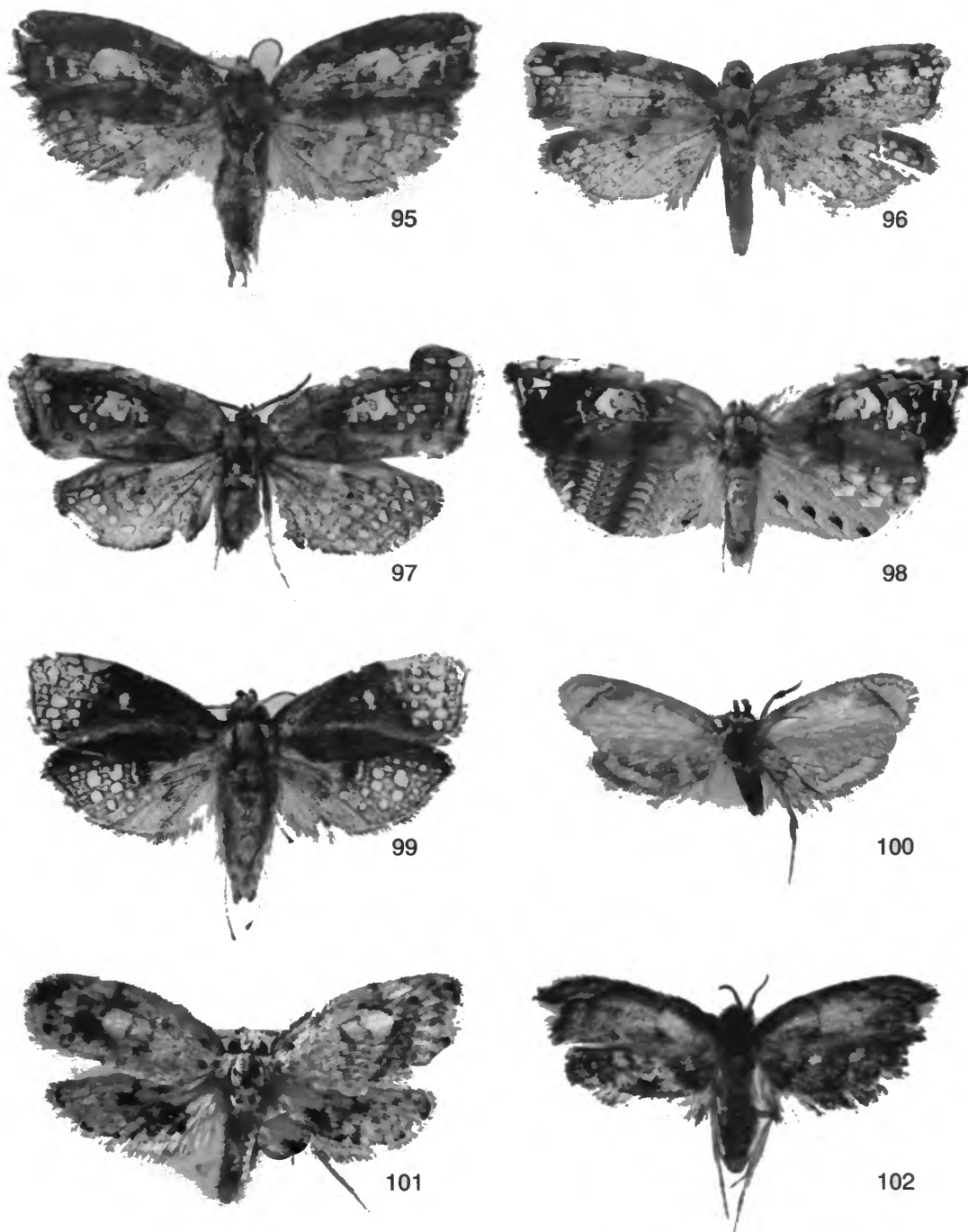

FIGURES 95–102.—Adults. *Cnissostages oleagina*: 95, male, Parque Nacional Corcovado, Costa Rica (12.0 mm); 96, male, St. Jean du Maroni, French Guiana (8.0 mm); 97, lectotype female, Venezuela (22.2 mm). *Cnissostages mastictor*: 98, female, Pumayacu, Peru (32.0 mm). *Cnissostages osae*: 99, holotype male, Corcovado National Park, Costa Rica (11.0 mm). *Dysoptus fasciatus*: 100, holotype male, basecamp, Cerro de la Neblina, Venezuela (4.1 mm). *Dysoptus pseudargus*: 101, holotype male, Pakitza, Peru (5.5 mm). *Dysoptus prolatus*: 102, holotype male, Estación Biología La Selva, Costa Rica (5.2 mm). (Forewing lengths in parentheses.)

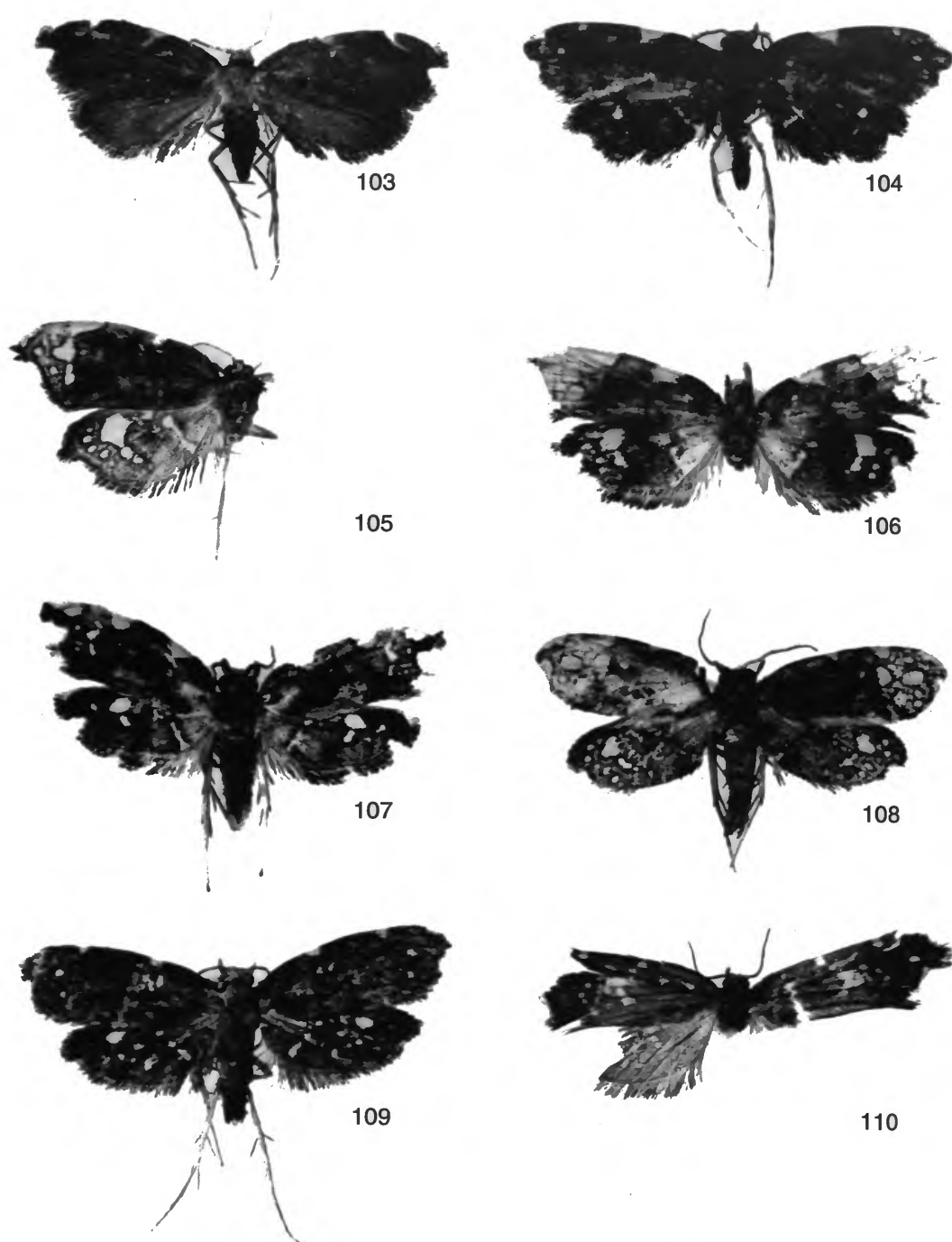

FIGURES 103–110.—Adults. *Dysoptus sparsimaculatus*: 103, holotype male, Rancho Grande, Venezuela (4.6 mm). *Dysoptus denticulatus*: 104, holotype male, Casa Grande, Brazil (5.0 mm). *Dysoptus anachoreta*: 105, holotype male, Sierra del Libano, Colombia (10.8 mm). *Dysoptus chiquitus*: 106, holotype male, Cabima, Panama (5.7 mm); 107, male, basecamp, Cerro de la Neblina, Venezuela (5.0 mm); 108, male, Rio Brillhante, Brazil (6.0 mm). *Dysoptus tantalota*: 109, male, basecamp, Cerro de la Neblina, Venezuela (6.0 mm). *Dysoptus probata*: 110, holotype female, Cerro Zunil, Guatemala (8.0 mm). (Forewing lengths in parentheses.)

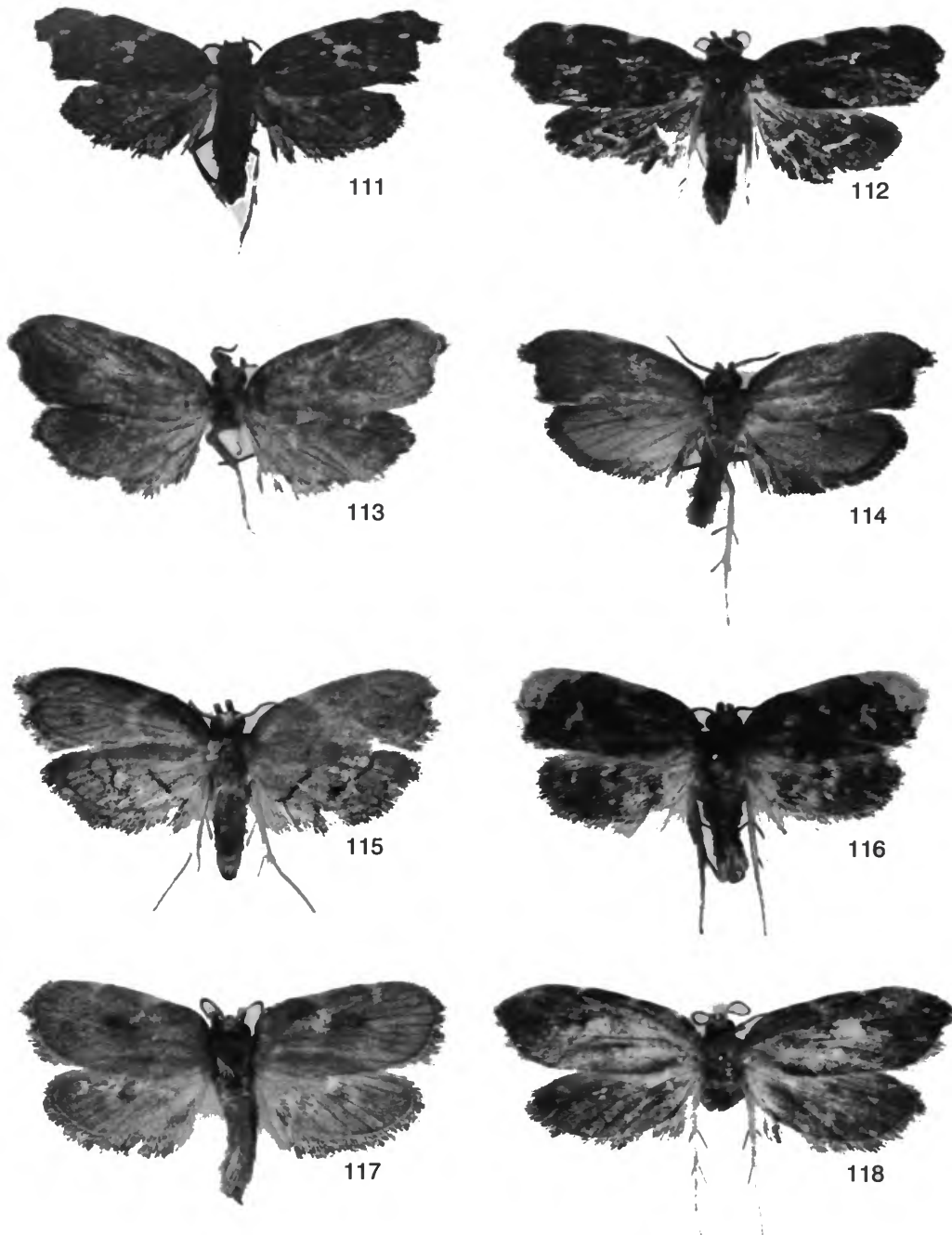

FIGURES 111–118.—Adults. *Dysoptus bilobus*: 111, holotype male, Estación Biología La Selva, Costa Rica (5.0 mm). *Dysoptus pentalobus*: 112, holotype male, Linhares, Brazil (4.8 mm). *Dysoptus avittus*: 113, holotype male, Santa Catarina, Brazil (6.0 mm). *Dysoptus asymmetrus*: 114, holotype male, basecamp, Cerro de la Neblina, Venezuela (4.4 mm). *Dysoptus acuminatus*: 115, holotype male, basecamp, Cerro de la Neblina, Venezuela (5.7 mm). *Dysoptus spilacris*: 116, holotype male, Estación Biología La Selva, Costa Rica (5.0 mm); 117, paratype male, Catemaco, Mexico (4.7 mm); 118, paratype female, Estación Biología La Selva, Costa Rica (8.8 mm). (Forewing lengths in parentheses.)

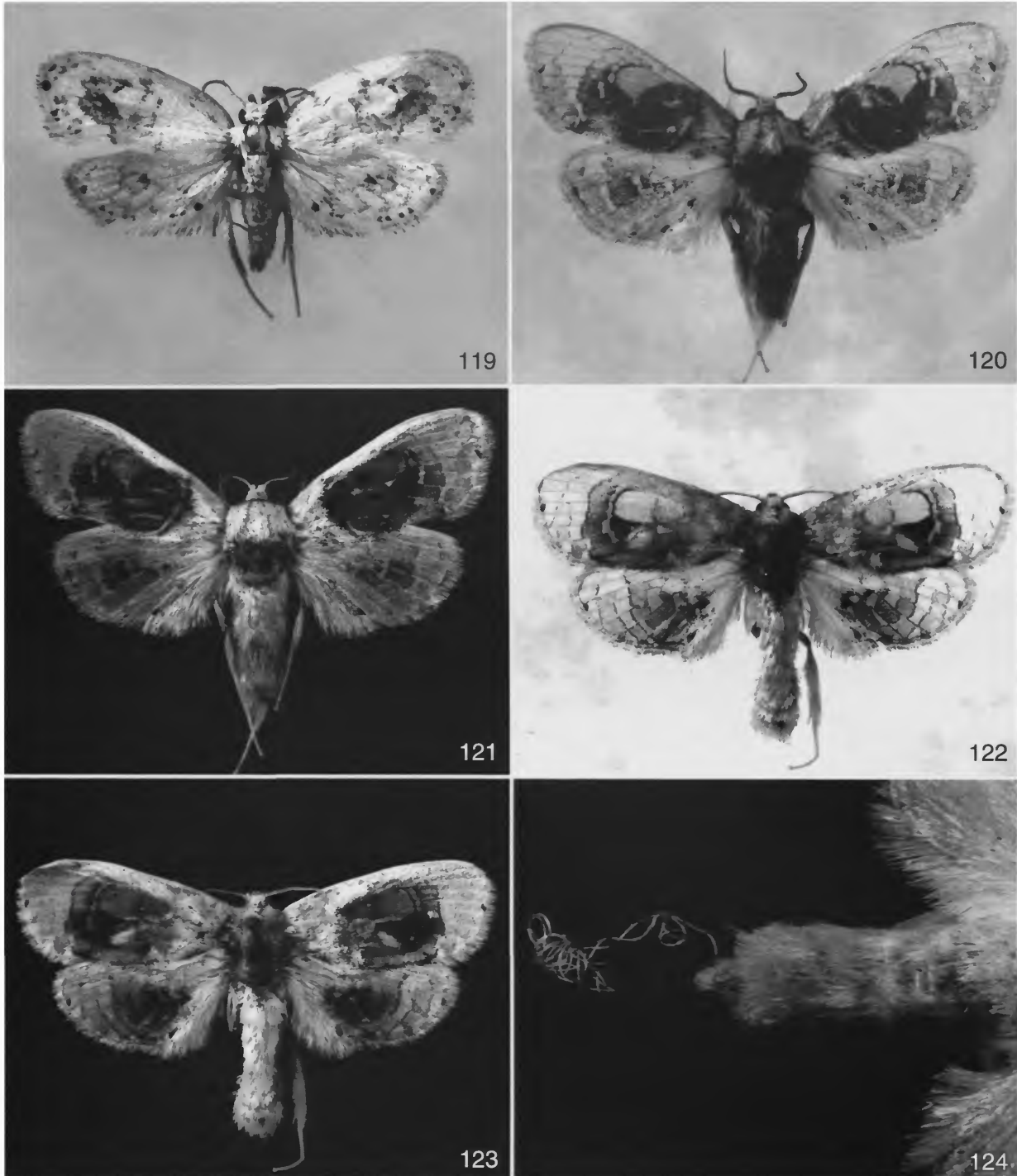

FIGURES 119–124.—Adults. *Dysoptus argus*: 119, holotype male, basecamp, Cerro de la Neblina, Venezuela (5.9 mm). *Arrhenophanes perspicilla*: 120, 121, male, basecamp, Cerro de la Neblina, Venezuela (15.5 mm). *Arrhenophanes volcanica*: 122, 123, male, Santa Catarina, Brazil (15.0 mm); 124, extruded vesica (vitta) from caudal end of abdomen (diameter of abdomen 3.4 mm). (Forewing lengths in parentheses, except as stated in Figure 119.)

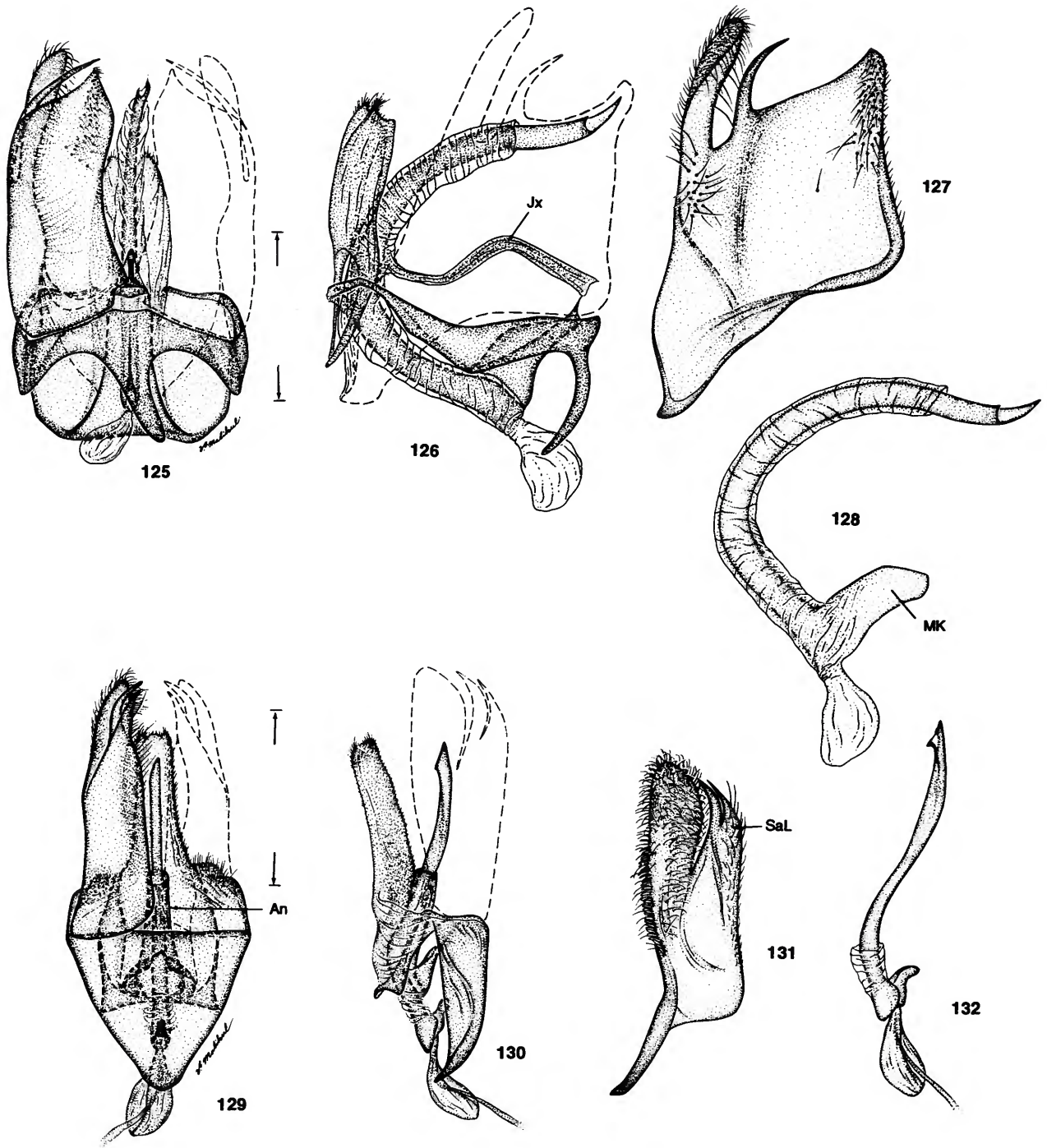

FIGURES 125-132.—Male genitalia. *Palaeophanes lativalva*: 125, ventral view (0.25 mm); 126, lateral view (Jx=juxta); 127, valva; 128, aedeagus. *Palaeophanes taiwanensis*: 129, ventral view (An=anellus, MK=median keel) (0.5 mm); 130, lateral view; 131, valva (SaL=saccular lobe); 132, aedeagus. (Scale lengths in parentheses.)

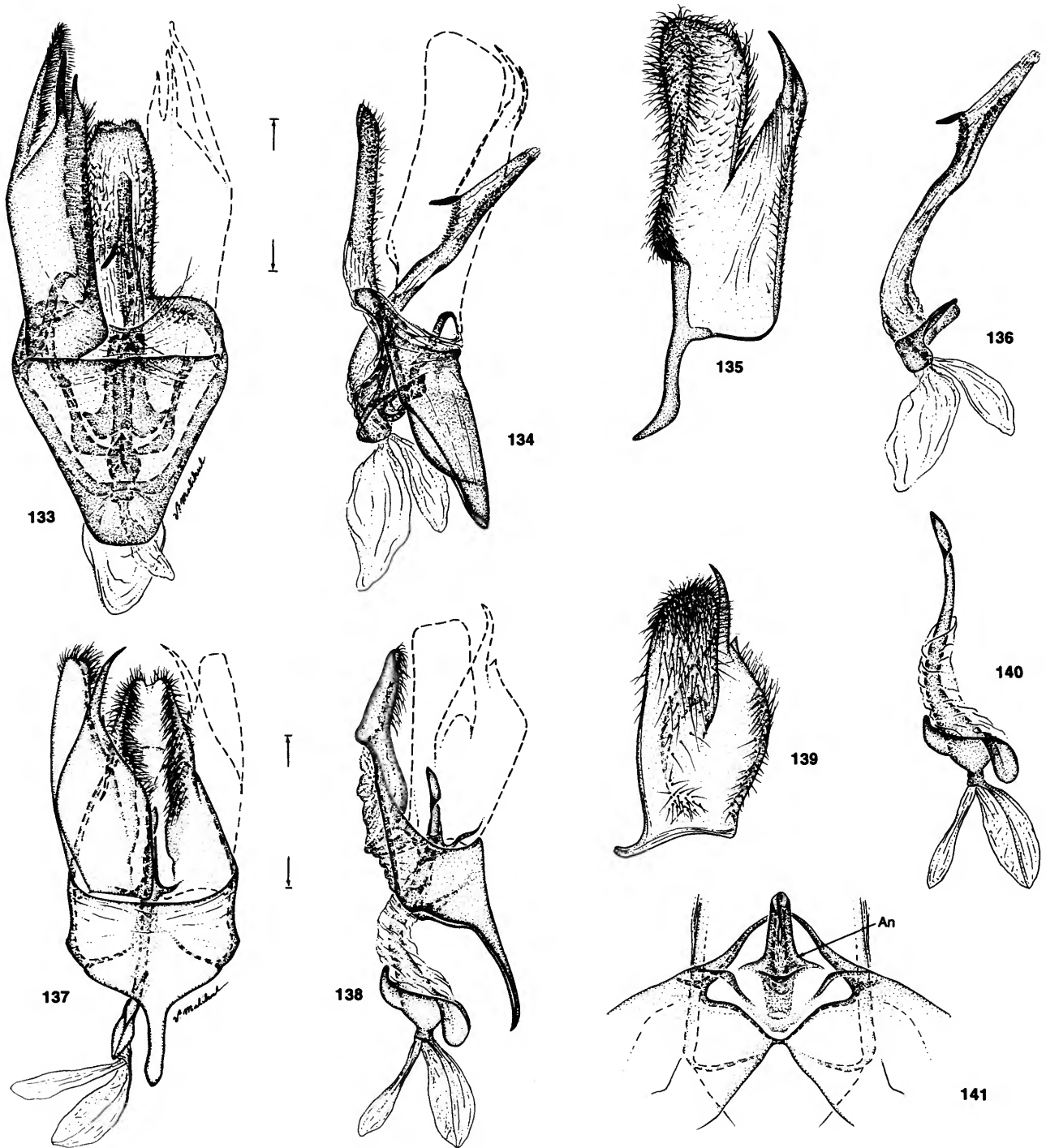

FIGURES 133–141.—Male genitalia. *Palaeophanes* sp.: 133, ventral view (0.5 mm); 134, lateral view; 135, valva; 136, aedeagus. *Palaeophanes brevispina*: 137, ventral view (0.5 mm); 138, lateral view; 139, valva; 140, aedeagus; 141, ventral view of anellus and base of valvae (An=anellus) (0.5 mm). (Scale lengths in parentheses.)

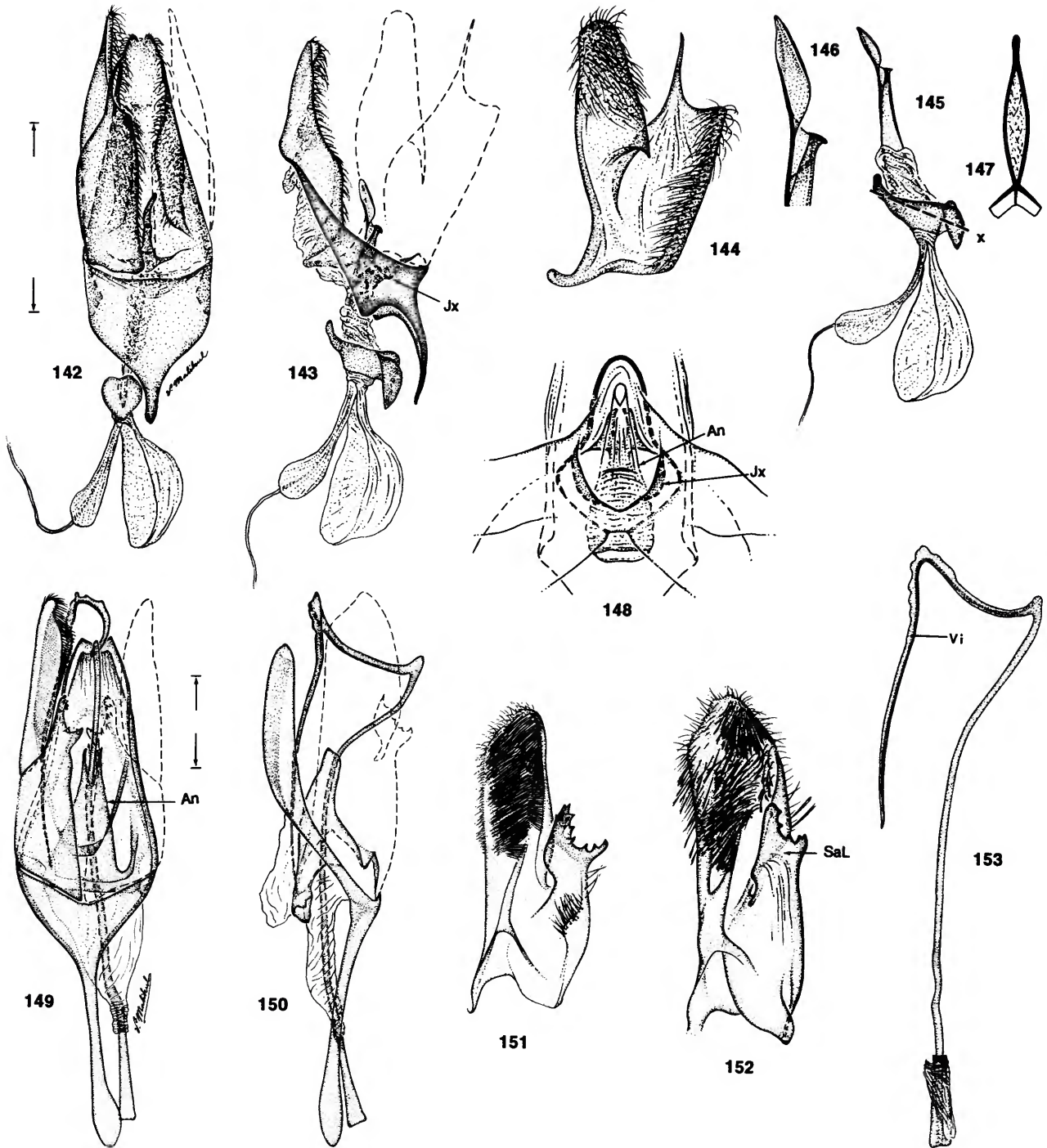

FIGURES 142-153.—Male genitalia. *Palaeophanes xoutha*: 142, ventral view (0.5 mm); 143, lateral view; 144, valva; 145, aedeagus; 146, enlarged apical view of Figure 145; 147, cross sectional view (see x in Figure 145) of basal "yoke" and midventral ridge of aedeagus; 148, ventral view of anellus and base of valvae (An=anellus; Jx=juxta). *Cnissostages oleagina*: 149, ventral view (0.5 mm); 150, lateral view; 151, valva; 152, valva of holotype (SaL=sacculus lobe) (0.5 mm); 153, aedeagus (Vi=vitta). (Scale lengths in parentheses.)

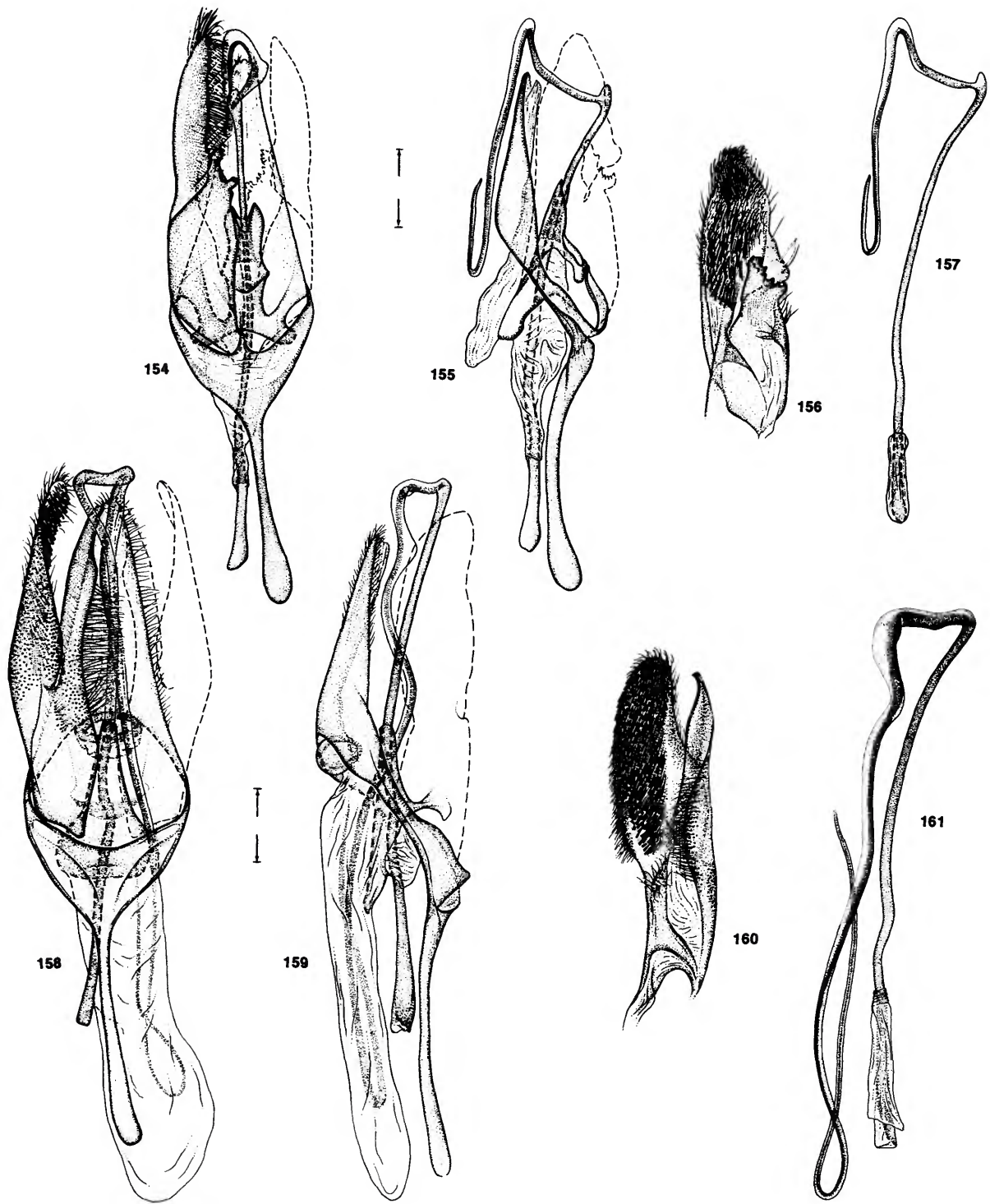

FIGURES 154-161.—Male genitalia. *Cnissostages mastictor*: 154, ventral view (1.0 mm); 155, lateral view; 156, valva; 157, aedeagus. *Cnissostages osae*: 158, ventral view (0.5 mm); 159, lateral view; 160, valva; 161, aedeagus. (Scale lengths in parentheses.)

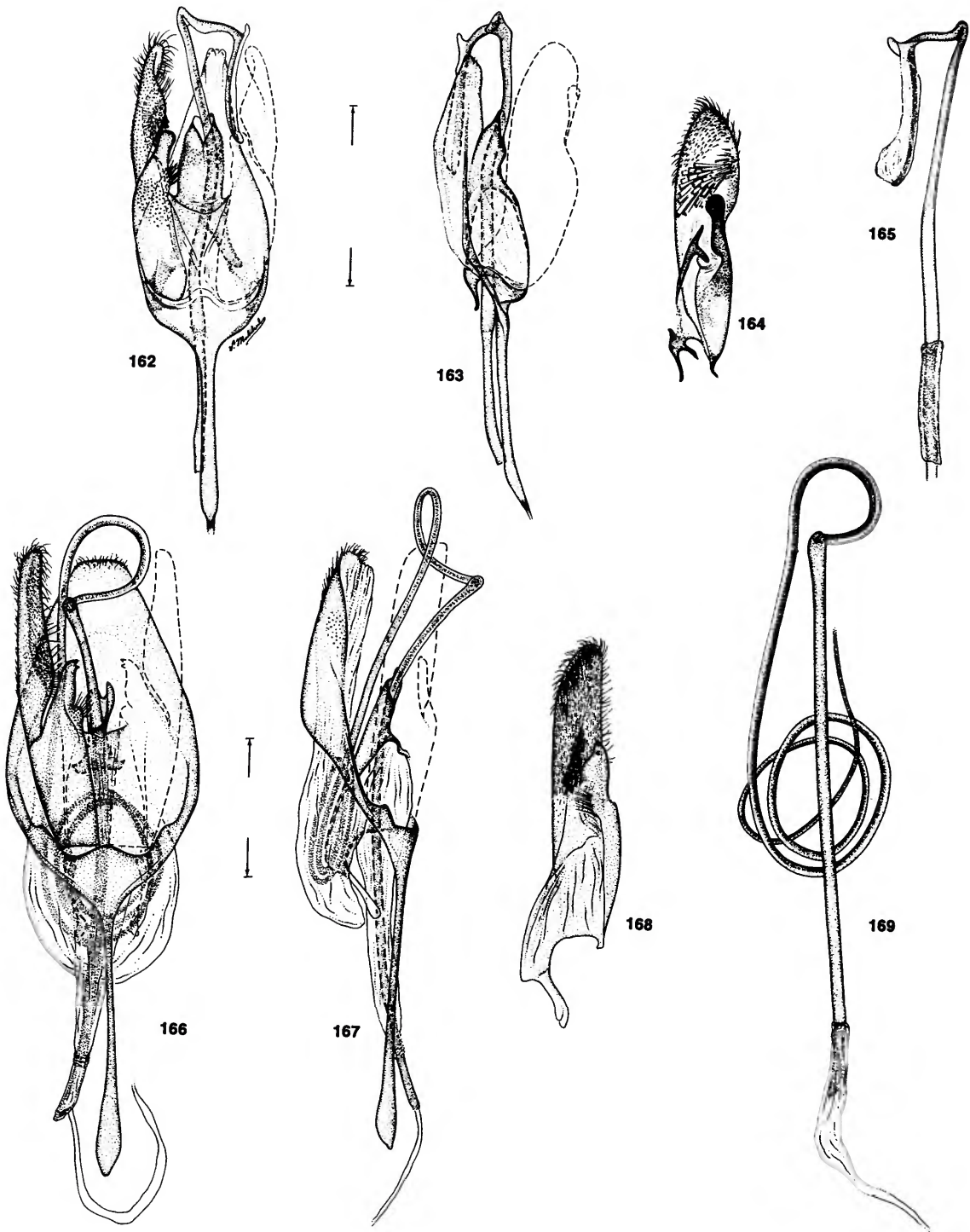

FIGURES 162-169.—Male genitalia. *Dysoptus fasciatus*: 162, ventral view (0.5 mm); 163, lateral view; 164, valva; 165, aedoeagus. *Dysoptus pseudargus*: 166, ventral view (0.5 mm); 167, lateral view; 168, valva; 169, aedoeagus. (Scale lengths in parentheses.)

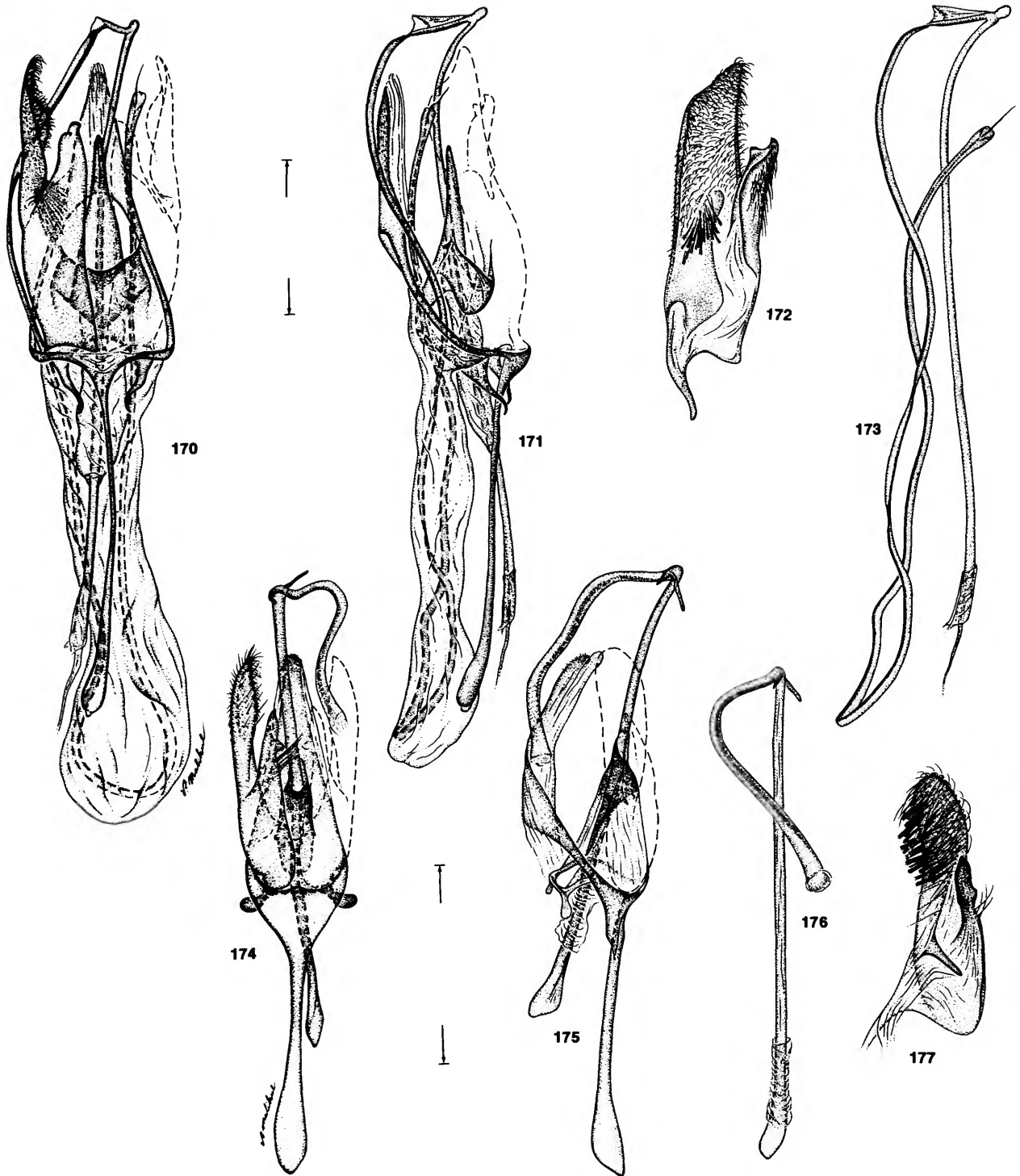

FIGURES 170–177.—Male genitalia. *Dysoptus prolatus*: 170, ventral view (0.5 mm); 171, lateral view; 172, valva; 173, aedeagus. *Dysoptus sparsimaculatus*: 174, ventral view (0.5 mm); 175, lateral view; 176, aedeagus; 177, valva. (Scale lengths in parentheses.)

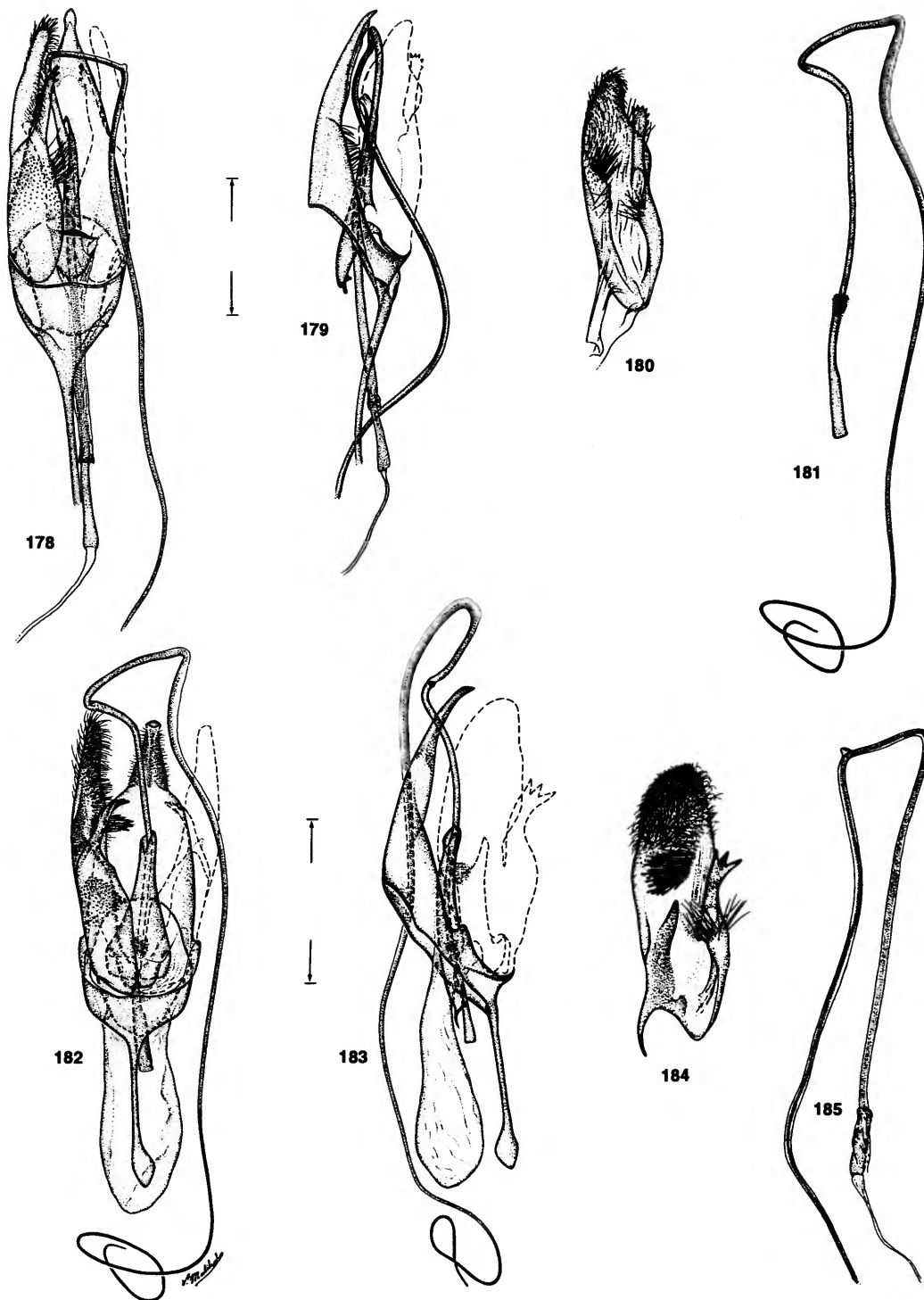

FIGURES 178-185.—Male genitalia. *Dysoptus denticulatus*: 178, ventral view (0.5 mm); 179, lateral view; 180, valva; 181, aedeagus. *Dysoptus anachoreta*: 182, ventral view (0.5 mm); 183, lateral view; 184, valva; 185, aedeagus. (Scale lengths in parentheses.)

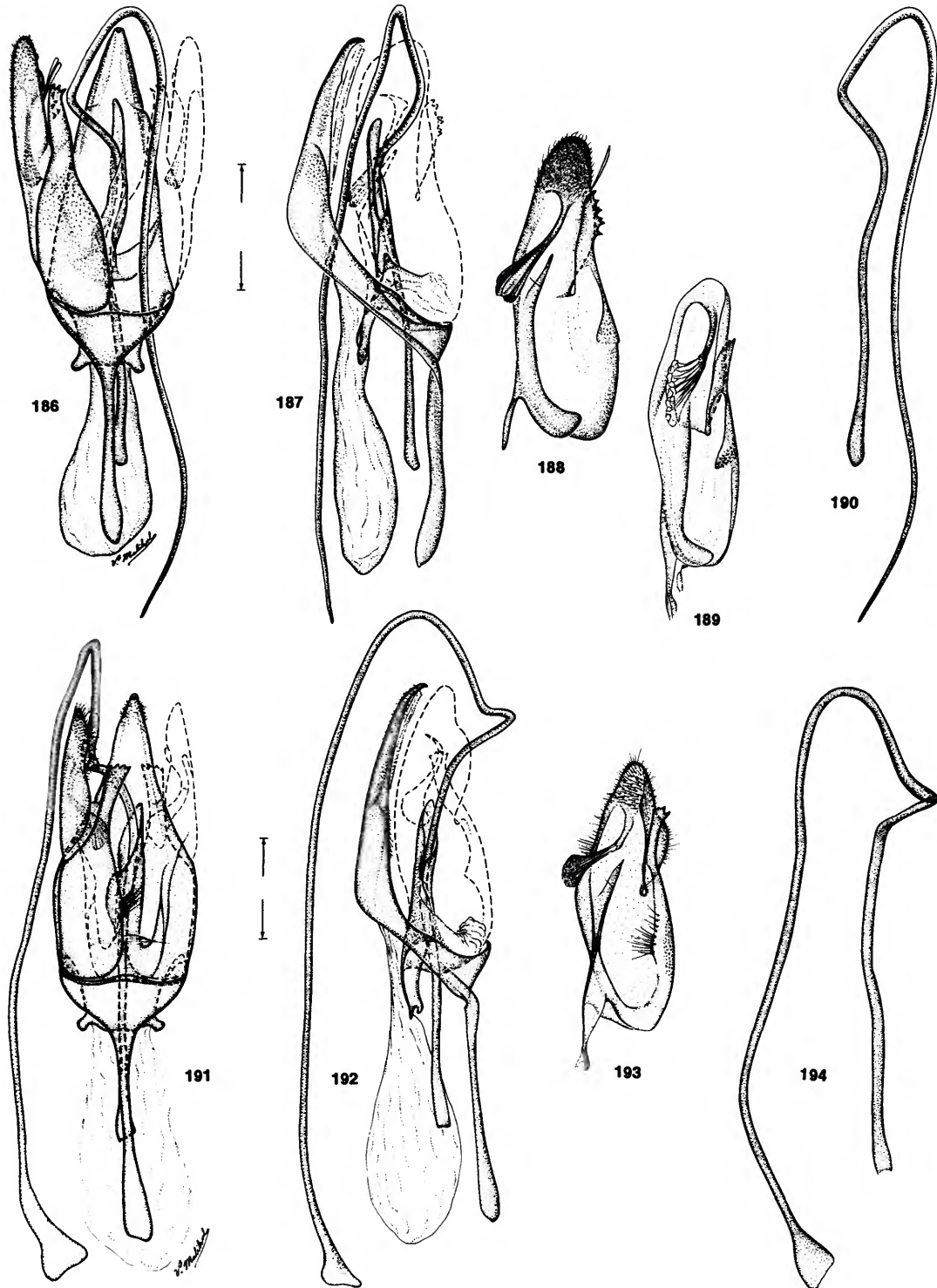

FIGURES 186-194.—Male genitalia. *Dysoptus chiquitus*: 186, ventral view (0.5 mm); 187, lateral view; 188, valva; 189, valva with pedunculate setae spread apart; 190, aedoeagus. *Dysoptus tantalota*: 191, ventral view (0.5 mm); 192, lateral view; 193, valva; 194, aedoeagus. (Scale lengths in parentheses.)

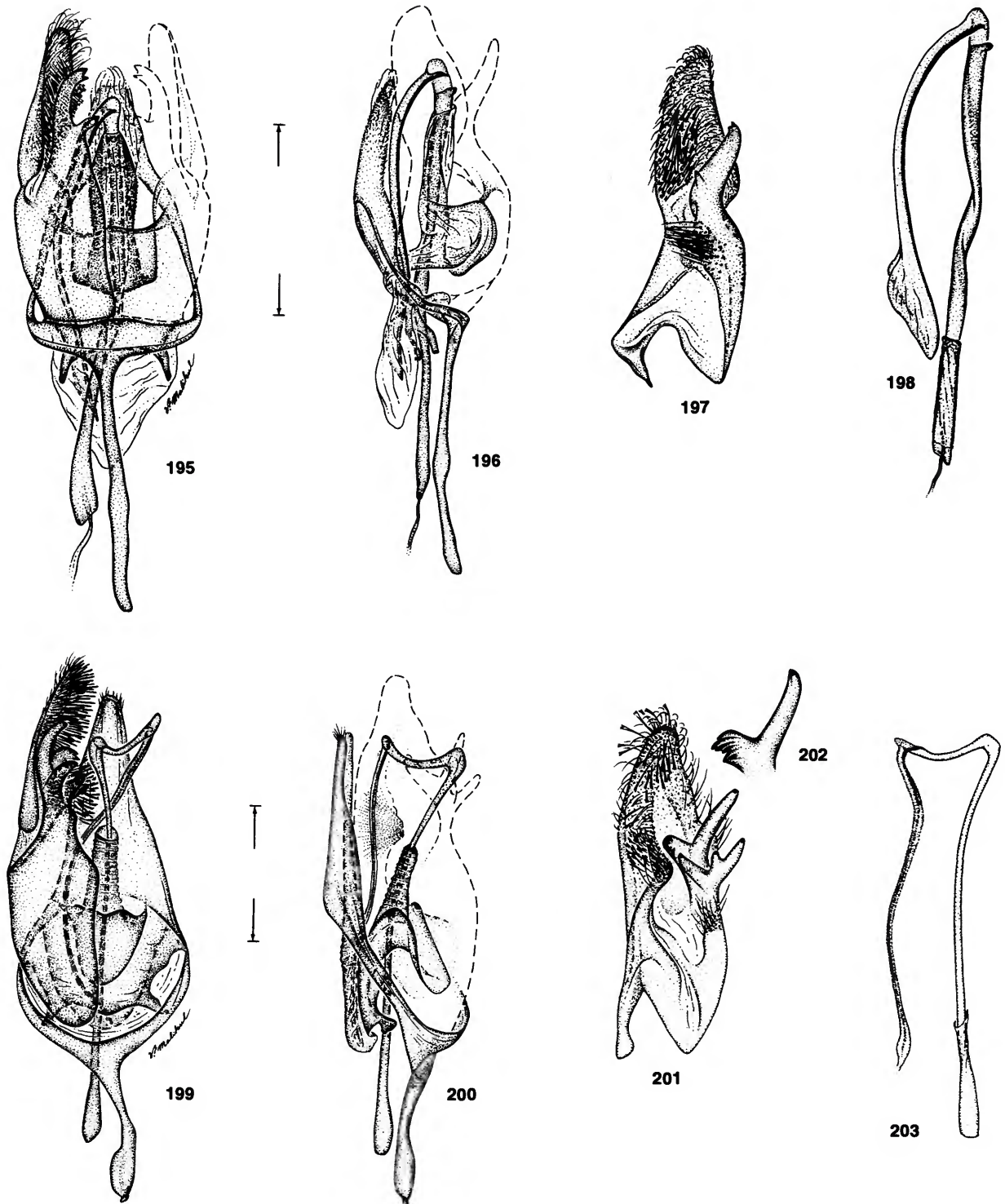

FIGURES 195-203.—Male genitalia. *Dysoptus bilobus*: 195, ventral view (0.5 mm); 196, lateral view; 197, valva; 198, aedeagus. *Dysoptus pentalobus*: 199, ventral view (0.5 mm); 200, lateral view; 201, valva; 202, detail of distal lobes; 203, aedeagus. (Scale lengths in parentheses.)

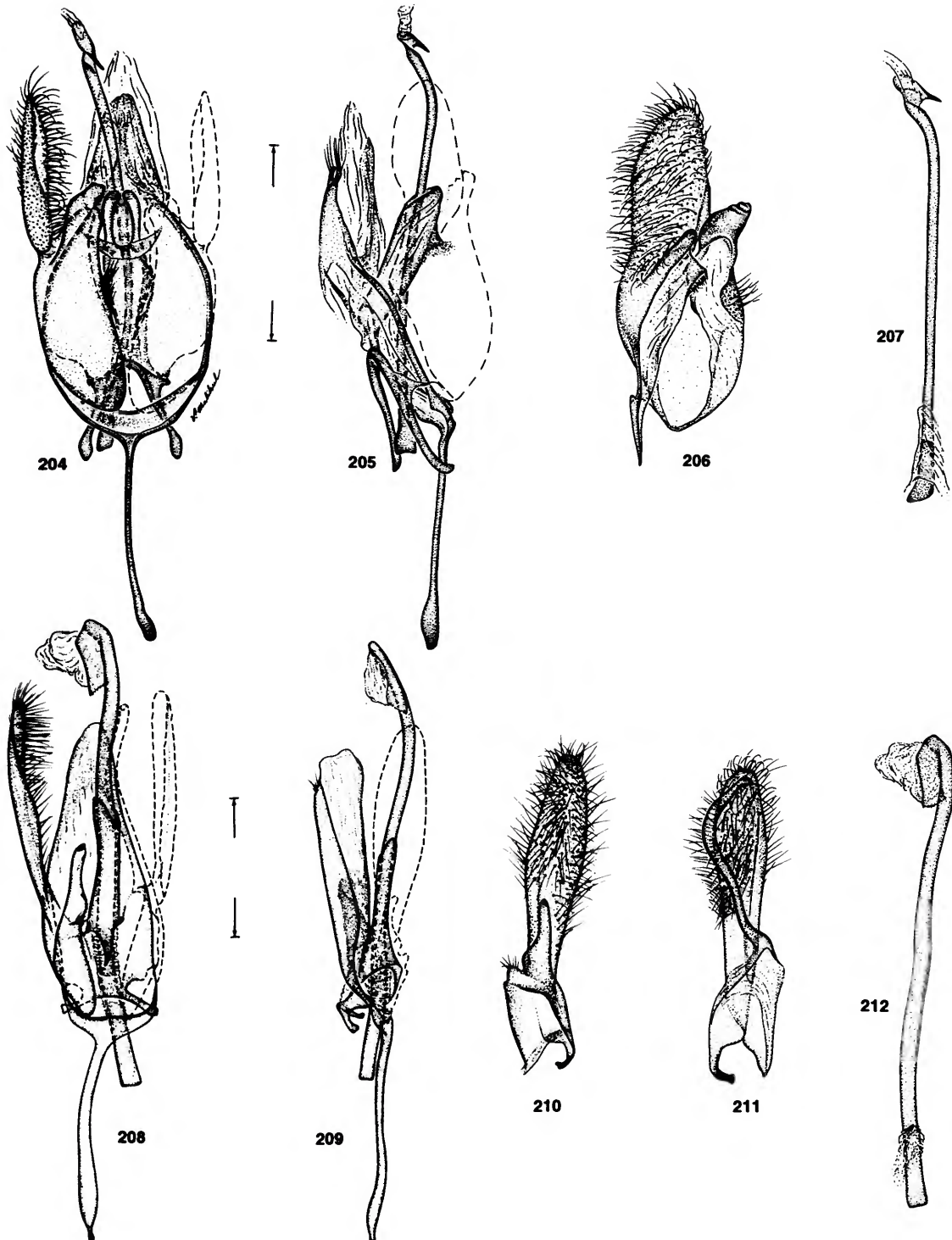

FIGURES 204-212.—Male genitalia. *Dysoptus avittus*: 204, ventral view (0.5 mm); 205, lateral view; 206, valva; 207, aedeagus. *Dysoptus asymmetricus*: 208, ventral view (0.5 mm); 209, lateral view; 210, left valva; 211, right valva; 212, aedeagus. (Scale lengths in parentheses.)

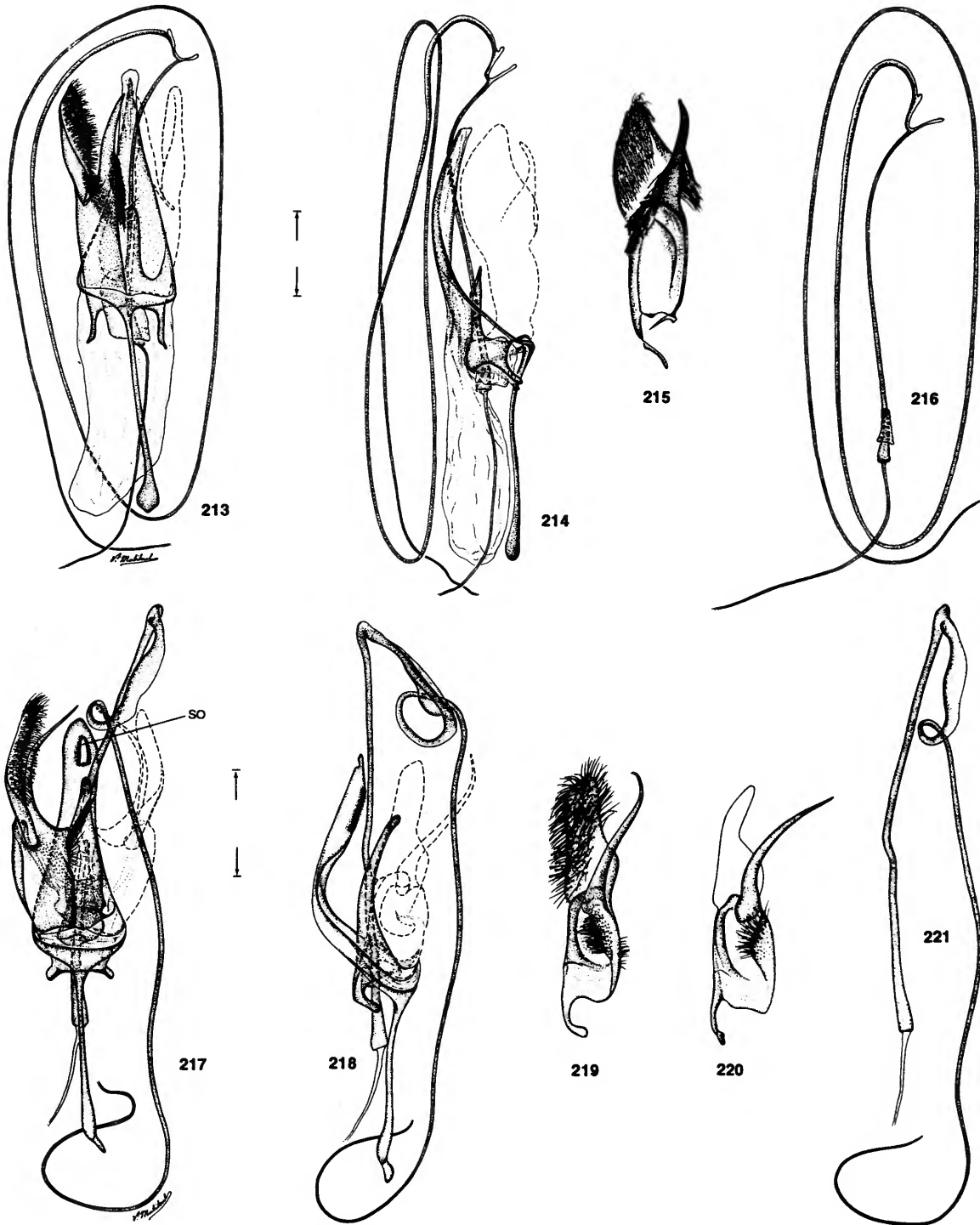

FIGURES 213–221.—Male genitalia. *Dysoptus acuminatus*: 213, ventral view (0.5 mm); 214, lateral view; 215, valva; 216, aedeagus. *Dysoptus spilacris*: 217, ventral view (SO=subtegumenal orifice) (0.5 mm); 218, lateral view; 219, valva showing mesal view of cucullus; 220, valva showing mesal view of sacculus; 221, aedeagus. (Scale lengths in parentheses.)

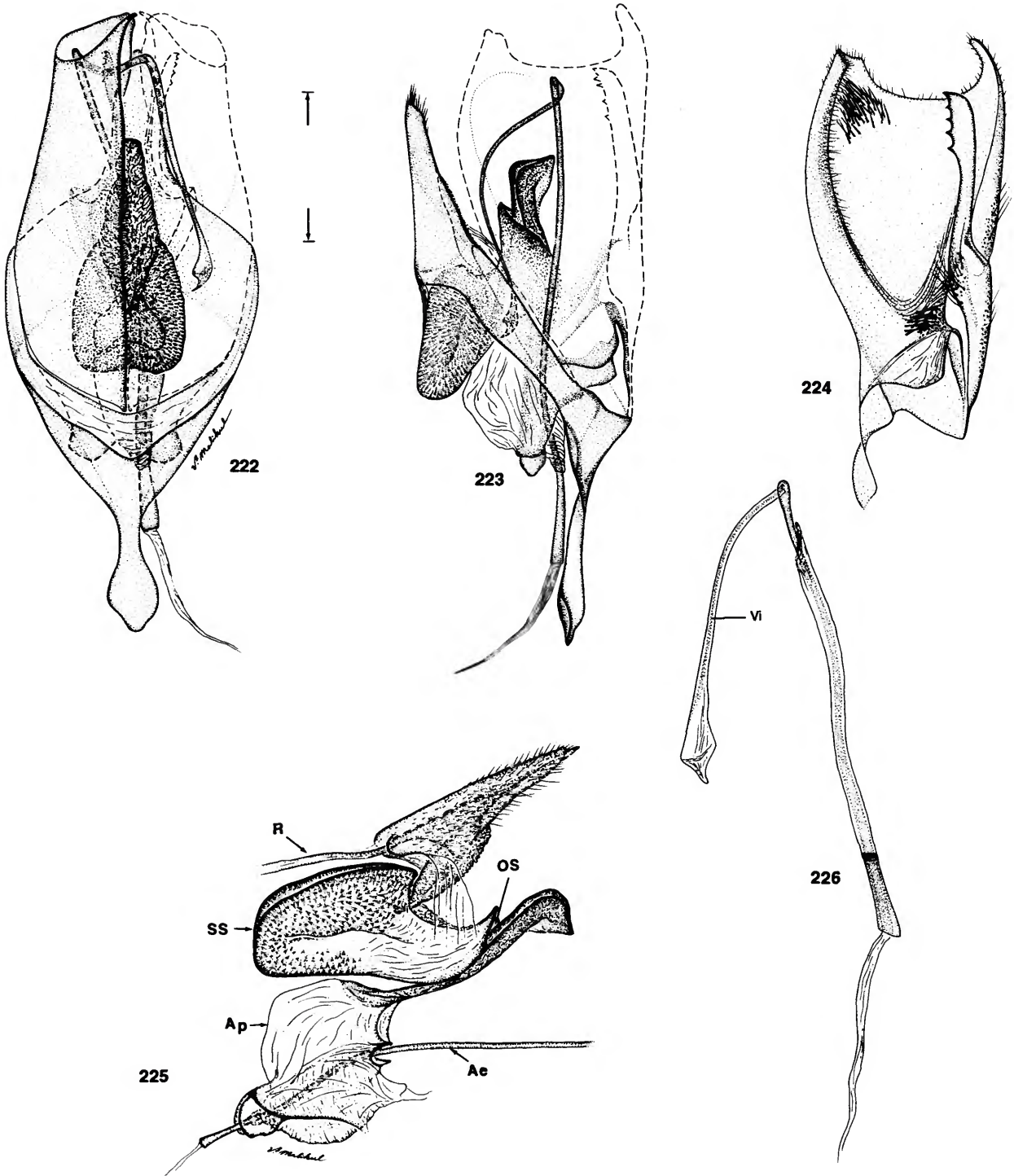

FIGURES 222-226.—Male genitalia. *Dysoptus argus*: 222, ventral view (0.5 mm); 223, lateral view; 224, valva; 225, lateral detail of spinose pocket (Ac=aedoeagus, Ap=apotheca, OS=orifice of spinose pocket (SP), R=rectum) (0.5 mm); 226, aedoeagus (Vi=vitta). (Scale lengths in parentheses.)

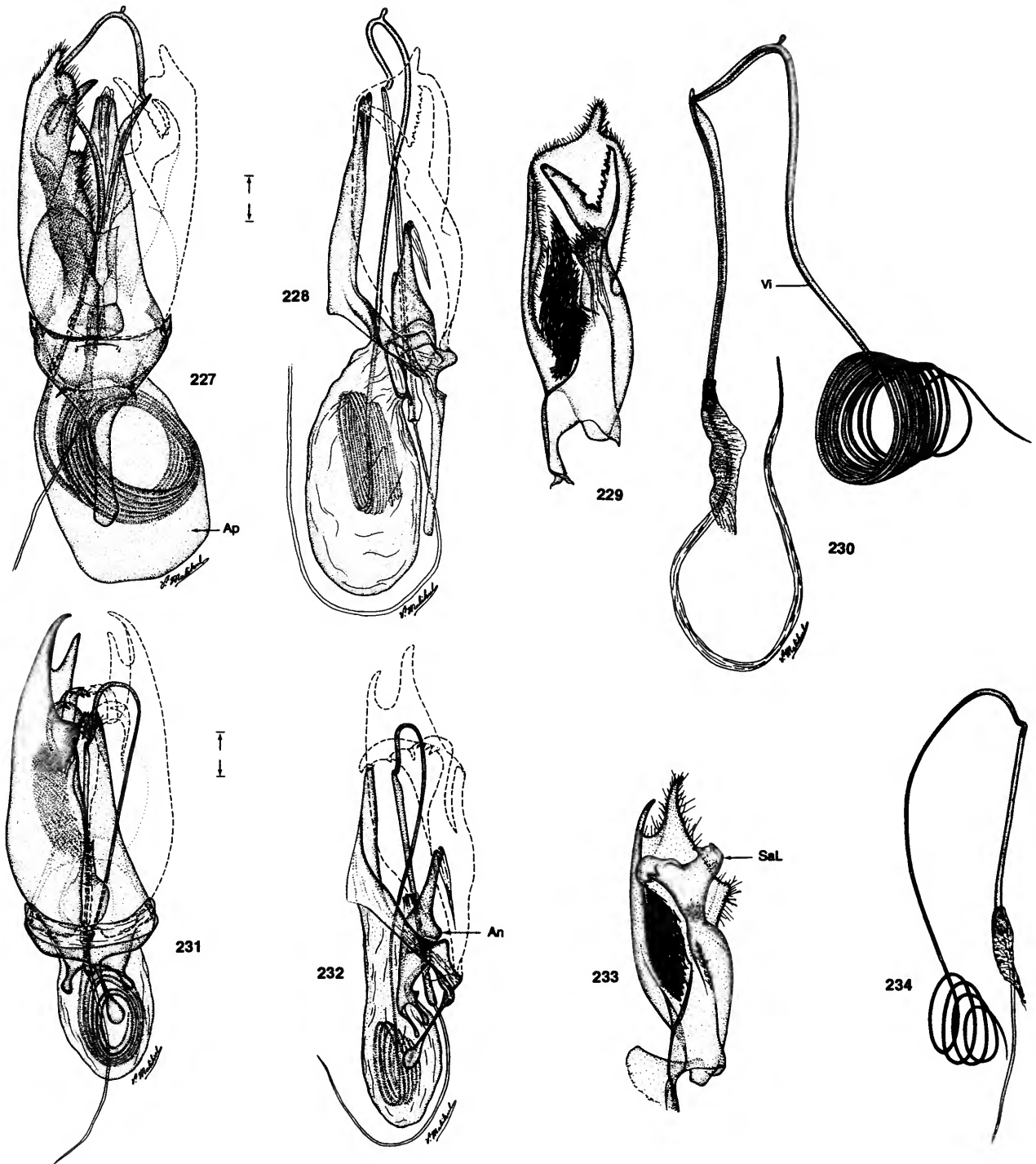

FIGURES 227-234.—Male genitalia. *Arrhenophanes perspicilla*: 227, ventral view (Ap=apotheca) (0.5 mm); 228, lateral view; 229, valva; 230, aedeagus (Vi=vitta). *Arrhenophanes volcanica*: 231, ventral view (0.5 mm); 232, lateral view (An=anellus); 233, valva (SaL=saccular lobe); 234, aedeagus. (Scale lengths in parentheses.)

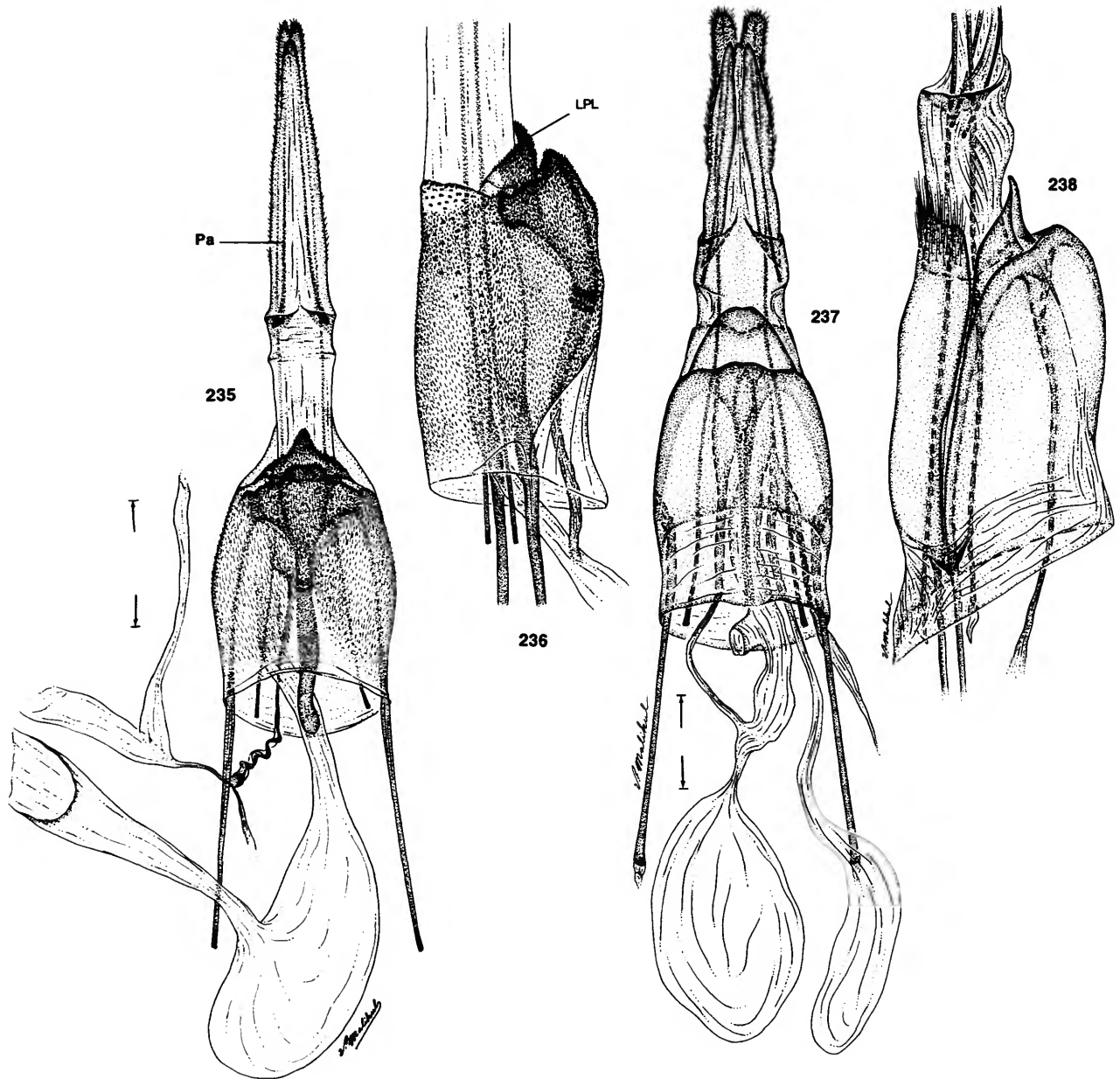

FIGURES 235–238.—Female genitalia. *Palaeophanes taiwanensis*: 235, ventral view (Pa=pseudapophysis) (0.5 mm); 236, lateral view of eighth segment (LPL=lamella postvaginellar lobe) (0.5 mm). *Notiophanes fuscata*: 237, ventral view (1.0 mm); 238, lateral view of eighth segment. (Scale lengths in parentheses.)

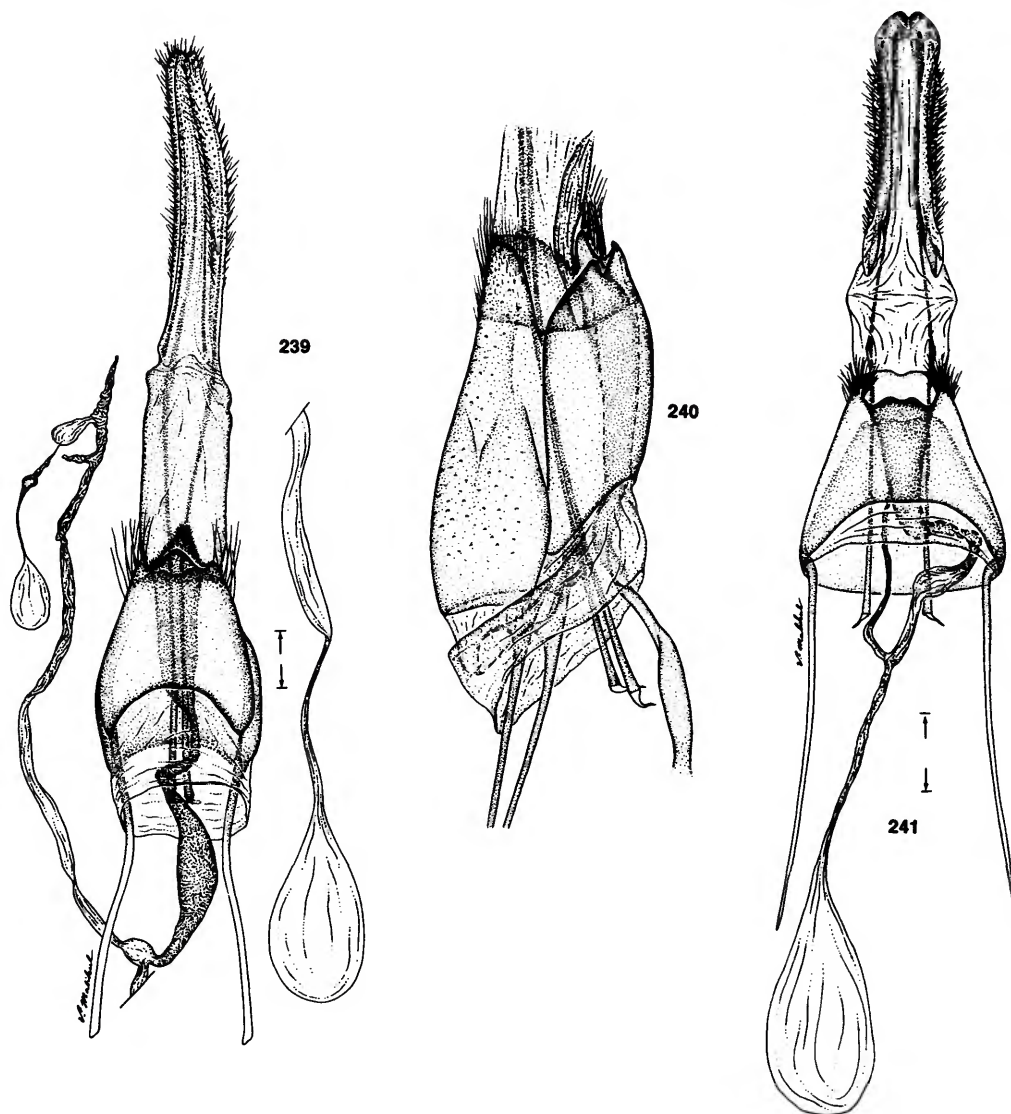

FIGURES 239–241.—Female genitalia. *Crissostages oleagina*: 239, ventral view (0.5 mm); 240, lateral view of eighth segment (0.5 mm). *Crissostages mastictor*: 241, ventral view (1.0 mm). (Scale lengths in parentheses.)

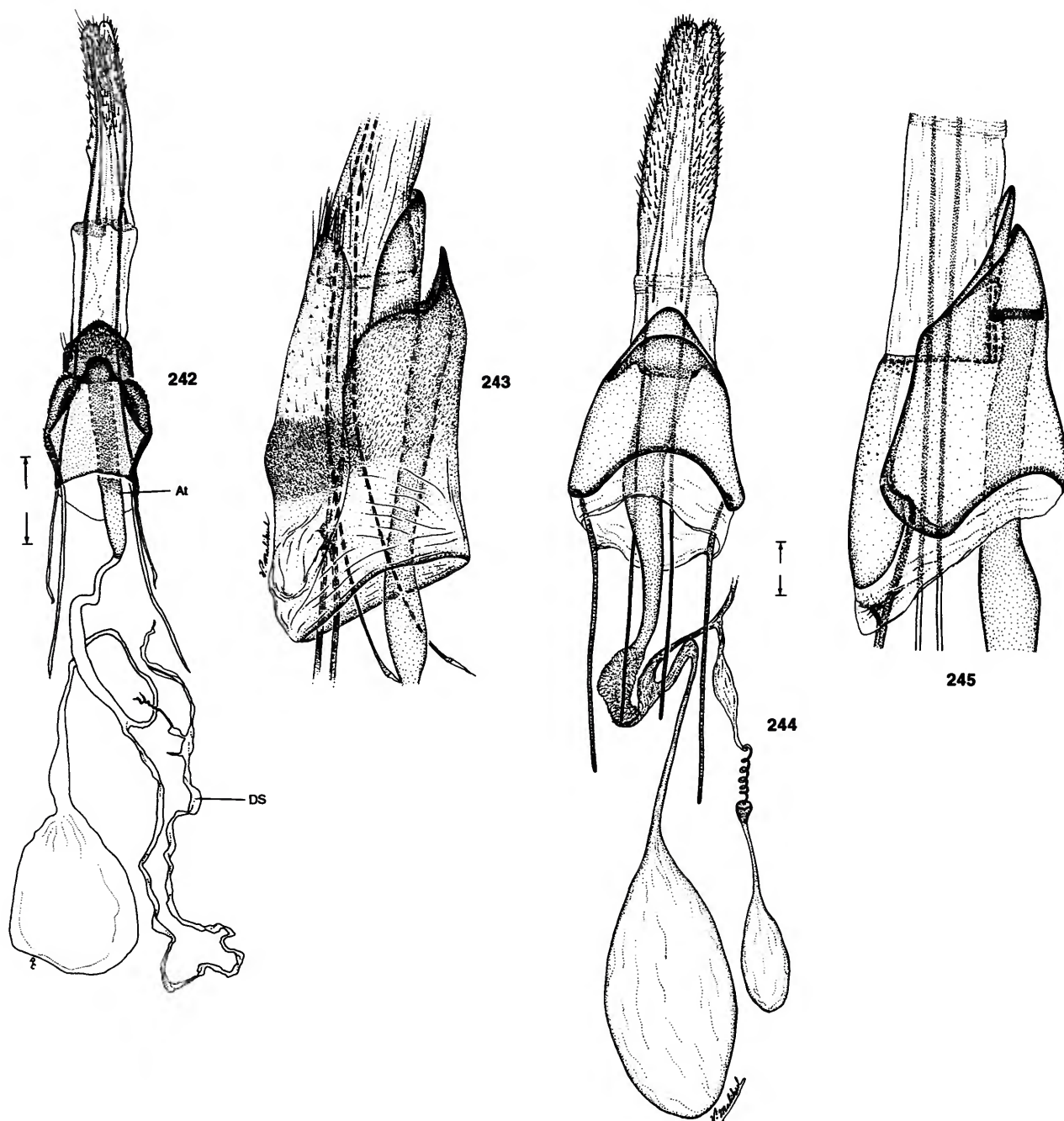

FIGURES 242–245.—Female genitalia. *Dysoptus chiquitus*: 242, ventral view (At=antrum, DS=ductus seminalis) (0.5 mm); 243, lateral view of eighth segment (0.5 mm). *Dysoptus probata*: 244, ventral view (0.5 mm); 245, lateral view of eighth segment. (Scale lengths in parentheses.)

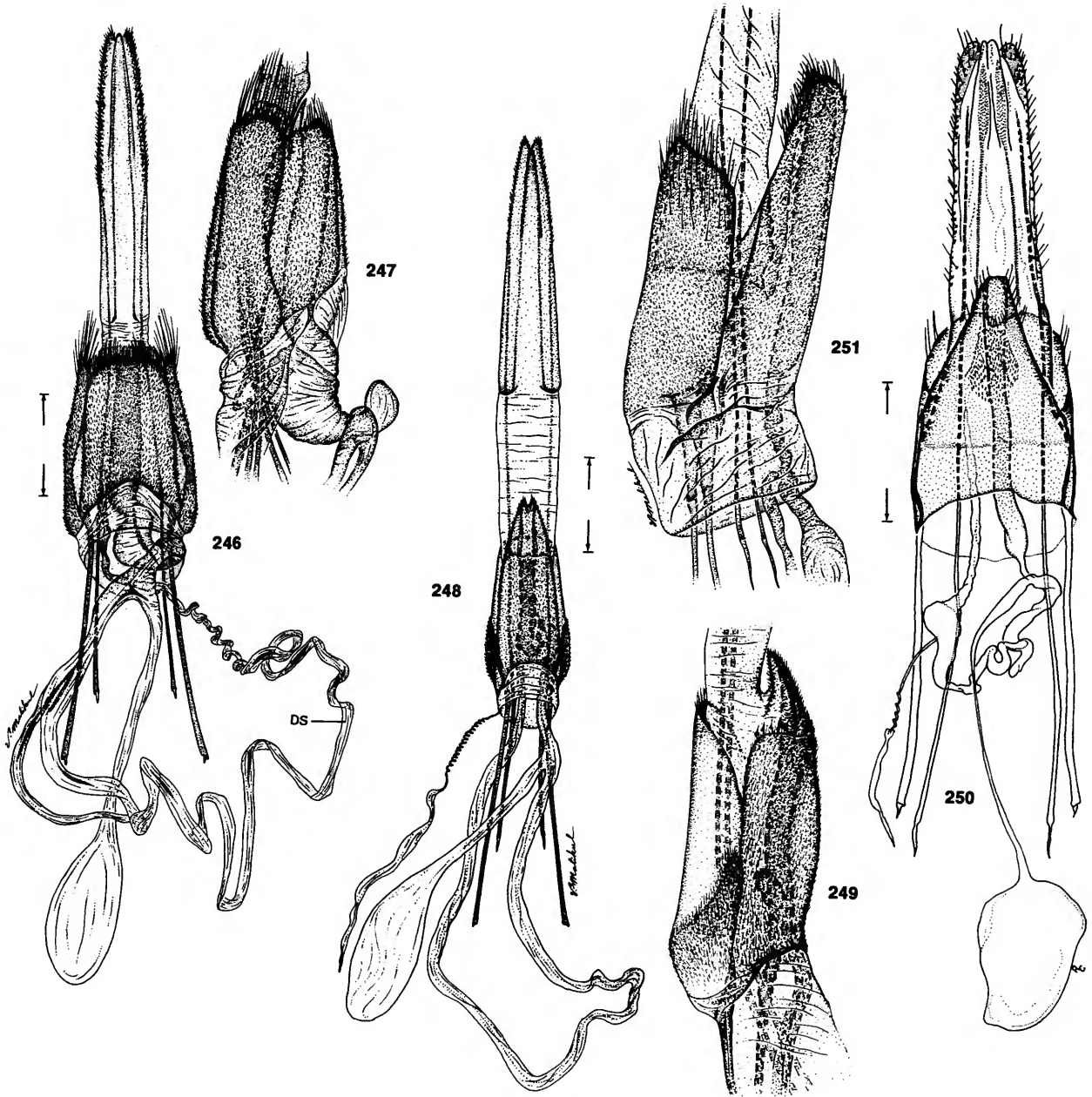

FIGURES 246-251.—Female genitalia. *Dysoptus spilacris*: 246, ventral view (DS=ductus seminalis) (0.5 mm); 247, lateral view of eighth segment (0.5 mm). *Dysoptus prolatus*: 248, ventral view; 249, lateral view of eighth segment. *Dysoptus argus*: 250, ventral view (0.5 mm); 251, lateral view of eighth segment. (Scale lengths in parentheses.)

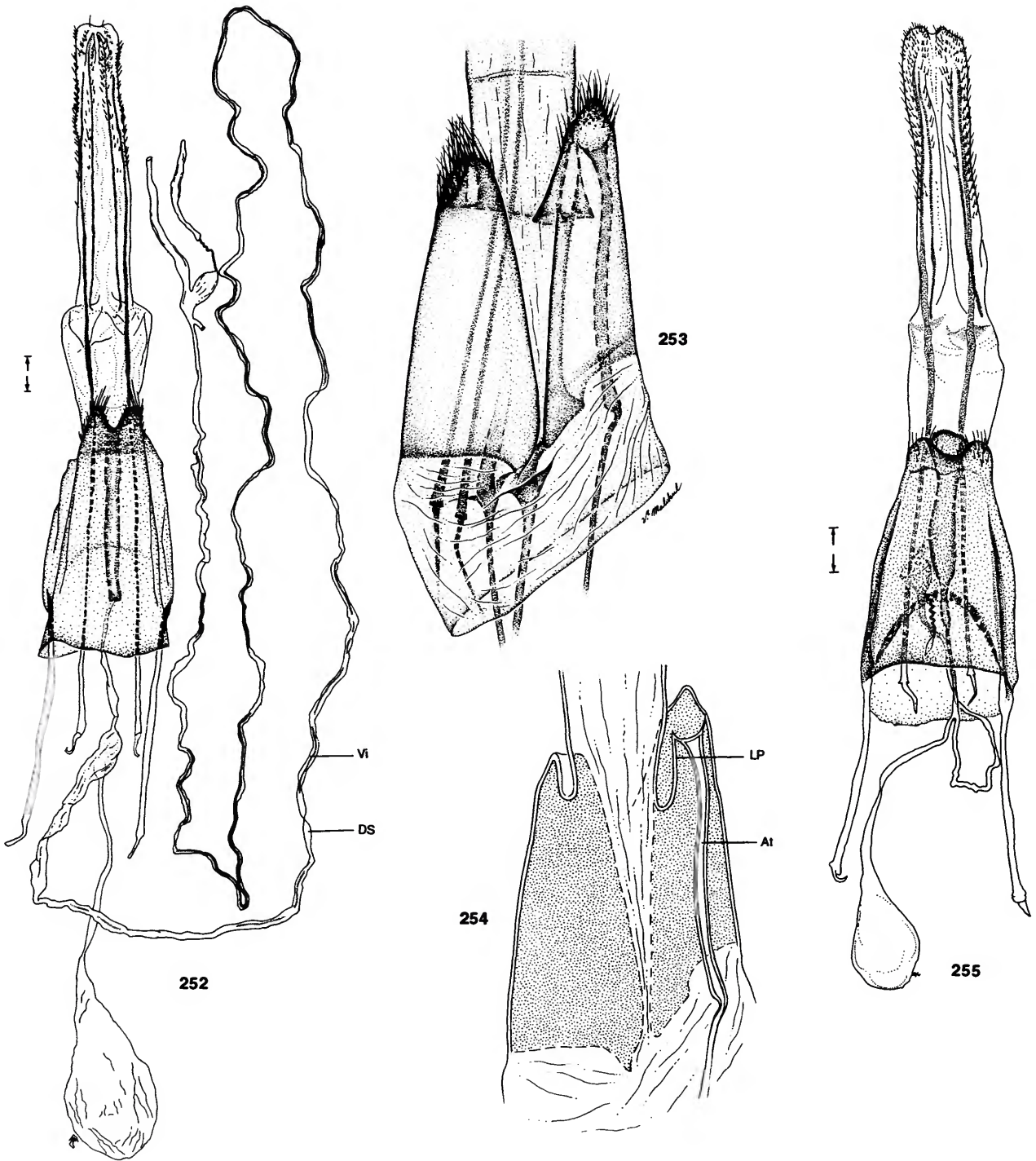

FIGURES 252-255.—Female genitalia. *Arrhenophanes perspicilla*: 252, ventral view (DS=ductus seminalis, Vi= fragment of vitta) (0.5 mm); 253, lateral view of eighth segment (0.5 mm); 254, sagittal view of Figure 253 (At= antrum, LP=inner wall of lamella postvaginalis). *Arrhenophanes volcanica*: 255, ventral view (0.5 mm). (Scale lengths in parentheses.)

REQUIREMENTS FOR SMITHSONIAN SERIES PUBLICATION

Manuscripts intended for series publication receive substantive review (conducted by their originating Smithsonian museums or offices) and are submitted to the Smithsonian Institution Press with Form SI-36, which must show the approval of the appropriate authority designated by the sponsoring organizational unit. Requests for special treatment—use of color, foldouts, case-bound covers, etc.—require, on the same form, the added approval of the sponsoring authority.

Review of manuscripts and art by the Press for requirements of series format and style, completeness and clarity of copy, and arrangement of all material, as outlined below, will govern, within the judgment of the Press, acceptance or rejection of manuscripts and art.

Copy must be prepared on typewriter or word processor, double-spaced, on one side of standard white bond paper (not erasable), with 1¹/₄" margins, submitted as ribbon copy (not carbon or xerox), in loose sheets (not stapled or bound), and accompanied by original art. Minimum acceptable length is 30 pages.

Front matter (preceding the text) should include: **title** page with only title and author and no other information; **abstract** page with author, title, series, etc., following the established format; table of **contents** with indents reflecting the hierarchy of heads in the paper; also, **foreword** and/or **preface**, if appropriate.

First page of text should carry the title and author at the top of the page; **second page** should have only the author's name and professional mailing address, to be used as an unnumbered footnote on the first page of printed text.

Center heads of whatever level should be typed with initial caps of major words, with extra space above and below the head, but no other preparation (such as all caps or underline, except for the underline necessary for generic and specific epithets). Run-in paragraph heads should use period/dashes or colons as necessary.

Tabulations within text (lists of data, often in parallel columns) can be typed on the text page where they occur, but they should not contain rules or numbered table captions.

Formal tables (numbered, with captions, boxheads, stubs, rules) should be submitted as carefully typed, double-spaced copy separate from the text; they will be typeset unless otherwise requested. If camera-copy use is anticipated, do not draw rules on manuscript copy.

Taxonomic keys in natural history papers should use the aligned-couplet form for zoology and may use the multi-level indent form for botany. If cross referencing is required between key and text, do not include page references within the key, but number the keyed-out taxa, using the same numbers with their corresponding heads in the text.

Synonymy in zoology must use the short form (taxon, author, year:page), with full reference at the end of the paper under "Literature Cited." For botany, the long form (taxon, author, abbreviated journal or book title, volume, page, year, with no reference in "Literature Cited") is optional.

Text-reference system (author, year:page used within the text, with full citation in "Literature Cited" at the end of the text) must be used in place of bibliographic footnotes in all Contributions Series and is strongly recommended in the Studies Series: "(Jones, 1910:122)" or "...Jones (1910:122)." If bibliographic footnotes are

required, use the short form (author, brief title, page) with the full citation in the bibliography.

Footnotes, when few in number, whether annotative or bibliographic, should be typed on separate sheets and inserted immediately after the text pages on which the references occur. Extensive notes must be gathered together and placed at the end of the text in a notes section.

Bibliography, depending upon use, is termed "Literature Cited," "References," or "Bibliography." Spell out titles of books, articles, journals, and monographic series. For book and article titles use sentence-style capitalization according to the rules of the language employed (exception: capitalize all major words in English). For journal and series titles, capitalize the initial word and all subsequent words except articles, conjunctions, and prepositions. Transliterate languages that use a non-Roman alphabet according to the Library of Congress system. Underline (for italics) titles of journals and series and titles of books that are not part of a series. Use the parentheses/colon system for volume (number):pagination: "10(2):5-9." For alignment and arrangement of elements, follow the format of recent publications in the series for which the manuscript is intended. Guidelines for preparing bibliography may be secured from Series Section, SI Press.

Legends for illustrations must be submitted at the end of the manuscript, with as many legends typed, double-spaced, to a page as convenient.

Illustrations must be submitted as original art (not copies) accompanying, but separate from, the manuscript. Guidelines for preparing art may be secured from the Series Section, SI Press. All types of illustrations (photographs, line drawings, maps, etc.) may be intermixed throughout the printed text. They should be termed **Figures** and should be numbered consecutively as they will appear in the monograph. If several illustrations are treated as components of a single composite figure, they should be designated by lowercase italic letters on the illustration; also, in the legend and in text references the italic letters (underlined in copy) should be used: "Figure 9b." Illustrations that are intended to follow the printed text may be termed **Plates**, and any components should be similarly lettered and referenced: "Plate 9b." Keys to any symbols within an illustration should appear on the art rather than in the legend.

Some points of style: Do not use periods after such abbreviations as "mm, ft, USNM, NNE." Spell out numbers "one" through "nine" in expository text, but use digits in all other cases if possible. Use of the metric system of measurement is preferable; where use of the English system is unavoidable, supply metric equivalents in parentheses. Use the decimal system for precise measurements and relationships, common fractions for approximations. Use day/month/year sequence for dates: "9 April 1976." For months in tabular listings or data sections, use three-letter abbreviations with no periods: "Jan, Mar, Jun," etc. Omit space between initials of a personal name: "J.B. Jones."

Arrange and paginate sequentially every sheet of manuscript in the following order: (1) title page, (2) abstract, (3) contents, (4) foreword and/or preface, (5) text, (6) appendices, (7) notes section, (8) glossary, (9) bibliography, (10) legends, (11) tables. Index copy may be submitted at page proof stage, but plans for an index should be indicated when the manuscript is submitted.

