



A phylogenetic analysis of the orb-weaving spider family Araneidae (Arachnida, Araneae)

NIKOLAJ SCHARFF

*Zoological Museum, University of Copenhagen, Department of Entomology,
Universitetsparken 15, DK-2100 Copenhagen, Denmark*

JONATHAN A. CODDINGTON

*Department of Entomology, NHB 105, National Museum of Natural History,
Smithsonian Institution, Washington, DC 20560, U.S.A.*

Received April 1993; accepted for publication August 1996

We present the first cladistic analysis focused at the tribal and subfamily level of the orb-weaving spider family Araneidae. The data matrix of 82 characters scored for 57 araneid genera of 6 subfamilies and 19 tribes (and 13 genera from 8 outgroup families) resulted in 16 slightly different, most parsimonious trees. Successive weighting corroborated 62 of the 66 informative nodes on these cladograms; one is recommended as the 'working' araneid phylogeny. The sister group of Araneidae is all other Araneoidea. Araneidae comprises two major clades: the subfamily Araneinae, and the 'argiopoid' clade, which includes all other subfamilies and most tribes (((Gasteracanthinae, Caerostreae), ((Micratheninae, Xylethrae), Encyosaccus), (Eurycorminae, Arciinae)), Cyrtarachninae), ((Argiopinae, Cyrtophorinae, Arachnureae)). Cyrtarachneae and Mastophoreae are united in a new subfamily, Cyrtarachninae. The spiny orb-weavers alone (Gasteracanthinae and Micratheninae) are not monophyletic. The mimetid subfamily Arciinae and the 'tetragnathid' genus *Zygiella* are araneids, but *Nephila* (and other tetragnathids) are not. On the preferred tree, web decorations (stabilimenta) evolved 9 times within 15 genera, and were lost once. The use of silk to subdue prey evolved once in cribellate and four times in ecribellate orb weavers. Sexual size dimorphism evolved once in nephilines, twice in araneids, and reverted to monomorphism five times. Evolution in other genitalic and somatic characters is also assessed; behavioral and spinneret features are most consistent (male genitalia, leg and prosomal features least consistent) on the phylogeny.

© 1997 The Linnean Society of London

ADDITIONAL KEY WORDS:—cladistics – methods – male genitalia – dimorphism – stabilimentum – Tetragnathidae – Mimetidae – *Zygiella*.

CONTENTS

Introduction	356
Methods	360

Character selection	363
Analysis	368
Character descriptions	370
Male sexual characters	371
Female sexual characters	376
Appendages	377
Cephalothorax	379
Eyes	380
Abdomen	383
Spinnerets	386
Behaviour	389
Results	395
Analysis	395
Character evidence for major clades	401
Discussion	403
Methodology	403
Phylogeny of Araneidae	404
Character evolution	410
Conclusions	422
Acknowledgements	423
References	424
Appendix. Character mappings and apomorphy lists	430

INTRODUCTION

The common orb-weavers of the spider family Araneidae are among the best known groups of spiders. For many people, layman and scientist alike, their geometric orb-webs typify 'spiders'. Their status as an icon of all spiders is reflected in the name—Araneidae is based on the type genus *Araneus* Clerck, 1757 (one year before Linnaeus), which is thus the basionym of both the family (Araneidae) and the order (Araneae). It is one of the largest spider families, with approximately 2600 described species in roughly 160 genera (Platnick, 1989a). Recent revisions of Neotropical araneids suggest that the global araneid species richness is much higher than the 2600 species presently known, with perhaps 6–7000 species estimated to exist (Coddington & Levi, 1991).

The family figures prominently in popular works, general textbooks and natural history books on spiders (McCook, 1889–94; Comstock, 1912a; Nielsen, 1932; Bristowe, 1939, 1941, 1958; Gertsch, 1949; Foelix, 1982, 1992; Jones, 1983; Roberts, 1995). The importance of Araneidae is also reflected in the amount of research published on this family. Since the turn of the century, some 900 papers have been published (Coddington *et al.*, 1991).

The Araneidae have already been a target of considerable phylogenetic and evolutionary research and speculation (Bertkau, 1878; Comstock, 1910; Kaston, 1964; Emerit, 1972; Robinson & Robinson, 1975, 1980; Lehtinen, 1978; Levi, 1978; Eberhard, 1982, 1990; Heimer, 1982; Heimer & Nentwig, 1982; Levi & Coddington, 1983; Coddington, 1986a, 1989, 1990a, b; Wunderlich, 1986). Some character systems are classic evolutionary problems, e.g. web form (Comstock, 1912b; Wiehle, 1931; Kaston, 1964; Robinson & Robinson, 1975; Craig, 1987; Vollrath, 1988, 1992; Eberhard, 1990; Shear, 1994), stabilimenta (Hingston, 1927, 1928, 1929; Robinson & Robinson, 1970; Eberhard, 1973, 1990; Lubin, 1975; Eisner & Novicki, 1983; Edmunds, 1986; Nentwig, 1986; Nentwig & Rogg, 1988; Craig & Bernard, 1990; Craig, 1994), mating behaviour (Robinson & Robinson, 1980), predatory

behaviour (Robinson, 1969; Robinson & Olazarri, 1971; Robinson & Robinson, 1974; Uetz 1986) and genitalia (Comstock, 1910; Gerhardt, 1911, 1921; Grasshoff, 1968, 1973, 1974a,b; Eberhard, 1985b). Araneid spiders have also been favourite animals for applied research. Psychopharmacologists have used araneid spiders as research animals when testing the effects of various drugs (e.g. LSD, Valium, strychnine, caffeine, etc.) on animal behaviour (Witt, Reed & Peakall, 1968). Fiber scientists have investigated the unusual properties of spider silk (Termonia, 1994; Work, 1976) and araneid spiders have been sent into orbit around earth to test their ability to build orb-webs under zero gravity (Witt *et al.*, 1976).

Since 1968, H. W. Levi has published more than 30 revisionary papers on the family and his work has helped to clarify the detailed morphology of many taxa and character systems. Levi (1992: 2) wrote that evolutionary analyses of generic relationships cannot be made until the relevant genera themselves are revised and that any premature analysis would have to be revised. Taken literally, this advice would postpone phylogenetic studies of Araneidae several centuries, as araneid taxonomy since Clerck in 1757 has averaged about 11 species a year and only about a third of the genera have been revised. All scientific work benefits from review, even purely descriptive systematics. It is worthwhile occasionally to assess the implication of descriptive work through rigorous analysis. Our results corroborate many hypotheses put forth in revisionary work. Some phylogenetic or homology hypotheses proposed in the literature appear questionable, mainly those that build on single characters or character systems. Viewing such hypotheses in the context of all characters is often the only way to detect such problems.

Given the immense size of Araneidae, it was neither feasible nor our intention to analyse the phylogeny of all araneid genera, but rather to infer the basic phylogenetic structure of the family by detecting its major lineages and their interrelationships. We aim for a first outline of araneid phylogeny: one that identifies the major clades; one that points out areas especially in need of future research; and one that stimulates other workers, especially researchers who specialize on particular character systems, to use the phylogeny and to evaluate critically the lineages and homologies it defines. Taxonomically, such a goal corresponds to tribal or subfamilial classification. We therefore tried to include representative genera of the groupings proposed by previous workers and in particular those proposed in the classical treatment by Simon (1892–5).

Simon's treatment (Table 1) is, in fact, the last comprehensive classification of Araneidae. Simon did not explain or justify his groupings, and it is not clear that he intended his classification to represent phylogeny. In addition, like many nineteenth century productive scientists, Simon occasionally changed his mind from one page to the next as he wrote. On page 594 he recognized nine araneid subfamilies (Table 1), but by page 763 he had apparently decided to sink five of the subfamilies (as serially numbered tribes) within an expanded Argiopinae. However, in order to have the most informative taxonomic hypothesis to test, we prefer to view Simon's original nine subfamily arrangement as his opinion on relationships, if not on rank. In Table 1 these former five tribes are assigned to the subfamilies Simon recognized earlier in his volume, but they are numbered in Table 1 with the tribal number he eventually assigned to them later in the volume. In sum, we regard Simon's Argiopinae as including only 23 of the 28 tribes assigned there on page 763, and allocate the five orphaned tribes to their original subfamilies as mentioned on page

TABLE 1. Simon's (1892–5) subfamily and tribal classification of Argiopidae. Within each tribe we list at least one genus. All genera included in this study are listed here except *Gastroxya*, *Pimosa*, and *Colphepeira* (which Simon probably would have considered Gasteracanthaceae, Linyphyceae or Meteace, and Araneae, respectively). Generic names subsequent to Simon have been listed in parentheses adjacent to the names under which he knew them. ‘*’ indicates taxa included in this study

Simon (1892–5)	Current placement
1. LINYPHIINAE	LINYPHIIDAE
1. Erigoneae	
2. Formicineae	
3. Linyphiace	
<i>Linyphia</i> *	
2. TETRAGNATHINAE	TETRAGNATHIDAE
1. Cyatholipeae	CYATHOLIPIDAE
<i>Cyatholipus</i>	
2. Pachygnatheae	TETRAGNATHIDAE
<i>Pachygnatha</i> *	
<i>Glenognatha</i>	
3. Tetragnatheae	TETRAGNATHIDAE
<i>Tetragnatha</i> *	
<i>Cyrtognatha</i>	
4. Meteace	TETRAGNATHIDAE
<i>Meta</i> *	
<i>Chrysomela</i>	
<i>Orsinome</i>	
<i>Argyroepeira</i> (= <i>Leucauge</i> *)	
5. Nesticeae	NESTICIDAE
<i>Nesticus</i>	
6. Azileae	TETRAGNATHIDAE
<i>Azilia</i>	
7. Diphyeae	TETRAGNATHIDAE
<i>Dolichognatha</i>	
3. NEPHILINAE	TETRAGNATHIDAE
1. Phonognatheae	
<i>Singolypta</i>	
<i>Phonognatha</i>	
2. Nephileae	
<i>Nephila</i> *	
<i>Nephilengys</i> *	
3. Clitactreae	
<i>Clitactra</i>	
4. Herenniaeae	
<i>Herennia</i>	
4. ARGIOPINAE	ARANEIDAE
1. Argiopeae	ARANEIDAE
<i>Argiope</i> *	
<i>Gea</i> *	
<i>Gea</i> (= <i>Neogea</i> *)	
2. Cyrtophoreae	ARANEIDAE
<i>Cyrtophora</i> *	
<i>Hentzia</i> (= <i>Mecynogea</i> *)	
3. Arachnureae	ARANEIDAE
<i>Arachnura</i> *	
4. Cycloseae	ARANEIDAE
<i>Cyclosa</i> *	
<i>Acusilas</i>	
<i>Nanoscolus</i>	
<i>Salassina</i> (= <i>Witica</i> *)	
5. Mangoreae	ARANEIDAE
<i>Spilasma</i>	
<i>Mangora</i> *	
<i>Larinia</i> *	
<i>Acacesia</i> *	
<i>Eustala</i> *	

TABLE 1.—*continued*

Simon (1892–5)	Current placement
6. Bertraneae <i>Bertrana</i> * <i>Spintharidius</i>	ARANEIDAE
7. Araneae <i>Araneus</i> * <i>Araneus</i> (= <i>Aculepeira</i> *) <i>Araneus</i> (= <i>Acanthepeira</i> *) <i>Araneus</i> (= <i>Alpaida</i> *) <i>Araneus</i> (= <i>Araniella</i> *) <i>Araneus</i> (= <i>Cercidia</i> *) <i>Araneus</i> (= <i>Hyphosinga</i> *) <i>Araneus</i> (= <i>Metazygia</i> *) <i>Araneus</i> (= <i>Metepeira</i> *) <i>Araneus</i> (= <i>Nuctenea</i> *) <i>Araneus</i> (= <i>Neoscona</i> *) <i>Araneus</i> (= <i>Singa</i> *) <i>Araneus</i> (= <i>Verrucosa</i> *) <i>Araneus</i> (= <i>Wixia</i> *) <i>Zygiella</i> * <i>Eriophora</i> * <i>Actinosoma</i> <i>Scoloderus</i> *	ARANEIDAE
8. Caerostreac <i>Caenostri</i> *	ARANEIDAE
9. Gasteracanthaceae <i>Gasteracantha</i> * <i>Gasteracantha</i> (= <i>Augusta</i> *) <i>Gasteracantha</i> (= <i>Aetrocantha</i> *) <i>Gasteracantha</i> (= <i>Austracantha</i> *) <i>Gasteracantha</i> (= <i>Macracantha</i> *) <i>Gasteracantha</i> (= <i>Isoxya</i> *) <i>Gasteracantha</i> (= <i>Togacantha</i> *) <i>Encyosaccus</i> *	ARANEIDAE
10. Micratheneae <i>Micrathena</i> * <i>Micrathena</i> (= <i>Enacrosoma</i> *) <i>Chaelacis</i> * <i>Pronous</i> *	ARANEIDAE
11. Xylethreac <i>Xylethrus</i> *	ARANEIDAE
12. Glyptogonaceae <i>Glyptogona</i>	ARANEIDAE
13. Anepsicac <i>Aspidolasius</i> * <i>Anepsion</i> *	ARANEIDAE
15. Physioleae <i>Physiola</i>	ARANEIDAE
16. Cyrtarachneae <i>Pasilobus</i> * <i>Paraplectana</i> <i>Cyrtarchne</i> *	ARANEIDAE
17. Glyptocranieae <i>Ondgarius</i> <i>Dichrostichus</i> <i>Cladomela</i> <i>Glyptocranium</i> (= <i>Mastophora</i> *)	ARANEIDAE

continued

TABLE 1.—*continued*

Simon (1892–5)	Current placement
18. Exechocentreae <i>Exechocentrus</i> <i>Coelossia</i>	ARANEIDAE
20. Celaeneae <i>Celaenia</i> <i>Taczanowskia</i>	ARANEIDAE
22. Dolophoncae <i>Dolophones*</i>	ARANEIDAE
23. Testudinareae <i>Testudinaria</i>	
24. Urseae <i>Ursa</i>	ARANEIDAE
25. Gnoleae <i>Gnolus</i>	MIMETIDAE
27. Chorizopeae <i>Chorizopes*</i> <i>Artonis</i>	ARANEIDAE
5. THERIDIOSOMATINAE	THERIDIOSOMATIDAE
26. Theridiosomateae <i>Epeirotypus</i> <i>Theridiosoma*</i>	
6. ARCIINAE	MIMETIDAE
21. Arcycae <i>Arkys*</i> <i>Archemorus</i>	
7. EURYCORMINAE	ARANEIDAE
14. Hypognatheae <i>Hypognatha*</i>	
8. AMAZULINAE	ANAPIDAE
28. Anapeae <i>Anapis</i>	
9. POLTYINAE	ARANEIDAE
19. Poltyeae <i>Poltyis</i> <i>Kava*</i>	

594. Our decisions thus reflect the more detailed of the two possible interpretations of Simon's ambiguous classification of Argiopinae.

Simon's Argiopidae is more similar to the modern-day superfamily Araneoidea than the family Araneidae. Simon suggested no groupings of the 23 tribes within his Argiopinae (roughly modern Araneidae). Some of Simon's tribes seem obviously monophyletic (Cyrtophoreae and Argiopeae), others not (e.g. Micratheneae, Anep-sieae, Araneae). Preliminary and incomplete phylogenetic schemes at the subfamily level exist, e.g. Levi (1983), Levi & Coddington (1983), but these were based on few data and taxa, were not quantitative, and are now outdated.

METHODS

Taxon selection

Seventy genera, representing nine families and three superfamilies, were included in this study.

The monophyly of the superfamily Araneoidea has been corroborated by several studies (Coddington, 1990a, b; Griswold *et al.*, in press). Different opinions exist on how to delimit Araneidae, and therefore on what the family contains. Some workers have included tetragnathids as a subfamily of Araneidae (Yaginuma, 1986; Wunderlich, 1986). Heimer & Nentwig (1982) included *Nephila* (often considered a tetragnathid) in Araneidae and suggested a sister group comprising Mimetidae, Archaeidae, Symphytognathidae, Anapidae, Cyatholipidae and Theridiosomatidae. Levi (1980b) suggested a clade comprising *Azilia*, *Pachygnatha*, and *Tetragnatha* (Tetragnathidae) as sister to Araneidae. In the most comprehensive examination of tetragnathid phylogeny to date, Hormiga, Eberhard & Coddington (1995) also recovered a monophyletic Tetragnathidae that included all of the above genera. Based on behavioral characters, Eberhard (1982) suggested a clade comprising Tetragnathidae, Theridiosomatidae and Anapidae, as sister group to Araneidae. Coddington (1986a, 1990a, b) suggested Linyphiidae or, equally well, a clade comprising all other araneoids as sister to Araneidae. We used the most recent cladistic analysis of araneoids (Griswold *et al.*, in press) to guide the selection of outgroups to Araneidae. They found that the sister group of Araneidae is all other araneoid families. In order to polarize characters within Araneidae correctly, the correct character vector must be present at the basal araneid node. No one distal araneoid is likely to represent the groundplan, and so we include representatives of all major araneoid lineages (symphytognathoids, theridioids, tetragnathids, and linyphioids; Griswold *et al.*, in press). Our analysis also tests whether the result of Griswold *et al.* (in press) for derived araneoids is robust when exposed to a much larger selection of araneid genera.

The limits of Araneidae with regard to several other araneoid families are controversial. Heimer & Nentwig (1991) included *Zygiella* in 'Metidae', but Roberts (1995) included *Zygiella* in Araneidae. Levi (1974a) included *Zygiella* in Araneidae (as did Levy, 1987), but Levi (1980b) transferred the genus to Tetragnathidae, where it remains (Platnick, 1993). As noted above, *Nephila* is often considered an araneid. Some araneid taxa may also belong in Mimetidae (Palpimanoidea) and vice versa. Mimetids had always been regarded as araneoids until Forster & Platnick (1984) found evidence to transfer the family to Palpimanoidea. They did not define the limits of Mimetidae, and Heimer (1984) later transferred *Arkys* and *Archemorus* (Arciinae, Table 1) to Mimetidae. Platnick & Shadab (1993) transferred *Gnolus* (Gnoleae, Table 1) to Mimetidae, synonymized Gnoleae with the mimetid subfamily Oarciinae, but rejected the placement of *Arkys* in Mimetidae. For these reasons, we include *Arkys* (and *Archemorus*) in the analysis, but omit *Gnolus*, as its relationships seem settled.

Optimizations at the ingroup (araneid) node are least problematic if subtended by a doublet of taxa, i.e. two nodes basal to it. Because the basal node of any cladogram, strictly speaking, is a trichotomy, we therefore included *Dictyna* (Dictynidae) and Deinopoidea (*Uloborus* (Uloboridae) plus *Deinopsis* (Deinopidae)) to clarify polarities and optimizations within Araneidae.

Araneid taxa were selected to represent most of Simon's classification relevant to the phylogeny of Araneidae (Simon, 1892–5; Table 1), as his classification is still the most comprehensive and detailed treatment of the family. We included 57 genera representing 19 of the 25 tribes still regarded as araneids (marked with an asterisk in Table 1). As noted above, Gnoleae, Anapeae (or Anapinae) and Theridiosomatae (or Theridiosomatinae) are not araneids according to latest research (Coddington 1986b, Eberhard, 1982; Platnick & Shadab, 1993). Due to

insufficient fresh material, we were unable to include Glyptogoneae, Physioleae, Exechocentreae, Celaeneae, Testudinareae, and Urseae. Three of the omitted tribes are monotypic, and material of all of them is rare in collections and usually in poor condition. Future research on araneid phylogeny might concentrate on adding these taxa to the analysis. From the point of view of characters, we wished to include and test as many informative, complex characters as possible; we chose genera with that end in mind. In so doing we intended to test these potentially valuable homology hypotheses by scoring them in a much broader selection of taxa. If substantial homoplasy is found (as judged against the background of the total data set), the existing hypotheses, or our extension of them to previously unstudied taxa, will have to be revised.

Exemplars

We chose to use real species to exemplify terminal taxa in this analysis rather than hypothetical constructs because we do not think hypothetical taxa that exemplify higher taxa (e.g. genera or tribes) can be reliably inferred at present. While the use of real taxa may introduce extra homoplasy into the analysis, and may not ideally mirror taxon groundplans, we feel these costs are outweighed by the benefit of presenting an empirically verifiable matrix to be expanded and improved by future work. As Levi (1992) noted, the ideal background for this analysis would be modern revisions of all araneid genera. Such revisions would make it easier to choose representative species from each genus to represent the generic groundplan. Levi's (1968–92) work on the New World fauna makes this possible for holarctic and some neotropical araneid genera, but similar high-quality revisionary work does not exist for the rest of the world. For Old World taxa we used what little was available to gain an overview of the genera: original descriptions, reviews, revisions, and, of course, examination of those taxa for which sufficiently intact 'scorable' material was available.

However, very few generic revisions include explicit phylogenetic, much less quantitative, analyses. Revisions that focus on new species, keys, and nomenclature frequently do not review critically or comprehensively the comparative morphology and ethology required for phylogenetic analysis of higher taxa. Indeed, in the absence of an overview of the family, it is difficult for anyone at the generic level to know, or even guess, which characters are important and worth commenting on. Consequently, generic revisions *per se*, while useful, cannot usually pinpoint which species best represent the generic groundplan.

Table 2 gives a list of the exemplar taxa examined. For the 70 genera included here we examined more than 100 species. When possible, we used the type species as an exemplar, but since those species are not necessarily typical for the genus we also examined other species from the same genus. Lack and quality of material were often limiting factors for rarer genera from tropical and austral regions. It can do more harm than good to include taxa for which no males are available, legs are missing, macrosetae broken off, spinnerets damaged, tapeta unrecognizable, and which have dried out several times in the last century. Many of the former characters are critical, and entering them as 'missing entries' can cause much ambiguity in the results (Platnick, Griswold & Coddington, 1991). The major part of the material examined came from the Smithsonian and Copenhagen collections, but important material was also borrowed from a number of helpful colleagues (see Acknowledgements).

TABLE 2. Exemplar taxa examined in connection with this study. An asterisk indicates type species for genus

* <i>Acacia hamata</i> (Hentz, 1847)	* <i>Gea spinipes</i> C. L. Koch, 1843
* <i>Acanthepeira stellata</i> (Walckenaer, 1805)	* <i>Hypognatha scutata</i> (Perty, 1833)
<i>Acanthepeira venusta</i> (Banks, 1896)	<i>Hyposinga rubens</i> (Hentz, 1847)
* <i>Aculepeira packardii</i> (Thorell, 1875)	* <i>Isoxya cicatricosa</i> (C. L. Koch, 1845)
* <i>Aetrocantha falkensteini</i> Karsch, 1879	<i>Isoxya tabulata</i> (Thorell, 1859)
<i>Alpaida bicornuta</i> (Taczanowski, 1878)	* <i>Kaira alba</i> (Hentz, 1850)
<i>Alpaida championi</i> (O.P.-Cambridge, 1889)	<i>Larinia borealis</i> (Hentz, 1847)
<i>Anepision depressum</i> (Thorell, 1877)	<i>Larinia directa</i> Banks, 1894
<i>Anepision peltoides</i> (Thorell, 1878)	<i>Leucauge argyra</i> (Walckenaer, 1841)
<i>Anepision roeveri</i> Chrysanthus, 1961	* <i>Linyphia triangularis</i> (Clerck, 1757)
<i>Arachnura feredayi</i> (L. Koch, 1872)	* <i>Macracantha arcuata</i> (Fabricius, 1793)
<i>Araneus diadematus</i> Clerck, 1757	<i>Mangora gibberosa</i> (Hentz, 1847)
* <i>Araneus angulatus</i> Clerck, 1757	<i>Mastophora cornigera</i> (Hentz, 1850)
<i>Araneus marmoreus</i> Clerck, 1757	<i>Mastophora bisaccata</i> (Emerton, 1884)
* <i>Araniella displicata</i> (Hentz, 1847)	<i>Mecynogea lemniscata</i> (Walckenaer, 1841)
* <i>Argiope lobata</i> (Pallas, 1772)	* <i>Aleta menardi</i> (Latreille, 1804)
<i>Argiope argentata</i> (Fabricius, 1775)	* <i>Metazygia wittfeldae</i> F. P.-Cambridge, 1903
<i>Argiope trifasciata</i> (Forskål, 1775)	<i>Metepeira arizonica</i> Chamberlin and Ivie, 1942
<i>Archemorus rosdorffi</i> Chrysanthus, 1971	<i>Metepeira labyrinthea</i> (Hentz, 1847)
<i>Arkys walckenaeri</i> Simon, 1879	<i>Micrathena aculeata</i> (Fabricius, 1775)
<i>Aspidolasius bifurcatus</i> Simon, 1897	* <i>Micrathena clypeata</i> (Walckenaer, 1805)
* <i>Aspidolasius branickii</i> (Taczanowski, 1879)	<i>Nephila clavipes</i> (Linnaeus, 1767)
<i>Aspidolasius</i> sp. (unidentified material from Peru)	* <i>Nephilengys malabarensis</i> (L. Koch, 1871)
* <i>Augusta glyphica</i> (F. E. Guerin-Meneville, 1840)	<i>Nephilengys cruentata</i> (Fabricius, 1775)
* <i>Austracantha minax</i> (Thorell, 1859)	* <i>Neogea egregia</i> (Kulczynski, 1911)
* <i>Bertrana striolata</i> Keyserling, 1884	<i>Neoscona oaxacensis</i> (Keyserling, 1863)
<i>Bertrana laselva</i> Levi, 1989	* <i>Neoscona arabesca</i> (Walckenaer, 1841)
<i>Caenostis sexcupidata</i> (Fabricius, 1793)	* <i>Nuctenea umbratica</i> (Clerck, 1757)
<i>Caenostis vinsoni</i> Thorell, 1868	<i>Pachygnatha autumnalis</i> Keyserling, 1884
* <i>Cercidia prominens</i> (Westring, 1851)	* <i>Pachygnatha clercki</i> Sundevall, 1823
* <i>Chaetacis aureola</i> (C. L. Koch, 1836)	<i>Pasilobus</i> sp. (unidentified species from Papua New Guinea, Australia and Tanzania)
<i>Chaetacis picta</i> (C. L. Koch, 1836)	<i>Pimnoa alticulata</i> Chamberlin and Ivie, 1943
<i>Chorizopes</i> sp. (unidentified material from Madagascar)	* <i>Pronous tuberculifer</i> Keyserling, 1880
* <i>Colphepeira catarba</i> (Banks, 1911)	<i>Scoloderus tuberculifer</i> Comstock, 1912
* <i>Cyclosa conica</i> (Pallas, 1772)	* <i>Scoloderus condatus</i> (Taczanowski, 1879)
* <i>Cyrtophora cibicola</i> (Forskål, 1775)	* <i>Singa hamata</i> (Clerck, 1757)
<i>Cyrtophora</i> sp. (unidentified material from Africa)	* <i>Tetragnatha extensa</i> (Linnaeus, 1758)
<i>Cyrtarachne ixodoidea</i> (Simon, 1870)	<i>Tetragnatha elongata</i> Walckenaer, 1805
<i>Deinopis spinosa</i> Marx, 1889	<i>Theridion flavonotatum</i> Becker 1879
<i>Dictyna arundinacea</i> (Linnaeus, 1758)	* <i>Theridion pictum</i> (Walckenaer 1805)
<i>Dolophones</i> sp. (unidentified species from Australia)	* <i>Theridiosoma geminosum</i> (L. Koch, 1878)
* <i>Enacrosoma anomala</i> (Mello-Leitao, 1932)	* <i>Togacantha nordvici</i> (Strand, 1913)
* <i>Encyosaccus sexmaculatus</i> Simon, 1895	<i>Uloborus glomus</i> (Walckenaer, 1841)
<i>Eriophora edax</i> (Blackwall, 1863)	* <i>Vermucosa arenata</i> (Walckenaer, 1841)
* <i>Eriophora ravilla</i> (C. L. Koch, 1845)	* <i>Witica crassicauda</i> (Keyserling, 1863)
* <i>Eustala anastera</i> (Walckenaer, 1841)	<i>Wixia georgia</i> (Levi, 1976)
* <i>Gasteracantha cancriformis</i> (Linnaeus, 1767)	<i>Wixia ectypa</i> (Walckenaer, 1841)
<i>Gasteracantha falcicornis</i> Butler, 1873	* <i>Xylethrus superbus</i> Simon, 1895
<i>Gasteracantha milvoidea</i> Butler, 1873	<i>Xylethrus scupeus</i> Simon, 1895
* <i>Gastroxya schoutedeni</i> Benoit, 1962	* <i>Zygiella atrica</i> (C. L. Koch, 1843)
<i>Gastroxya leleupi</i> Benoit, 1962	
<i>Gea heptagon</i> (Hentz, 1850)	

Character selection

The character matrix (Table 3) includes all the informative characters we could find, especially those that previous work on the family had identified as potentially informative. As noted above, character hypotheses also guided taxon selection; if a

17. Distal hematodocha: abs; pres;	-----100000000--0--000000?0000-0000?11111111101100001111111011	5	.20	.80	.16
18. Paramedian apophysis: abs; pres;	000000000011111110000000000000000111000000000000000000000000010	6	.16	.58	.10
19. Stipes: abs; pres;	000000000010000000000000000000000000000100011000110000010000001000010	7	.14	.45	.07
20. Subterminal apophysis: abs; pres;	0000000000100	4	.25	.76	.19
21. Subterminal apophysis: norm; bubble;	-----0-----0-----0000000001111111101111111000000	2	.50	.00	.00
22. Terminal apophysis: abs; pres;	000000000001000000000000000000000000000111111111111111111111111	3	.33	.92	.31
23. Embolus tip: simple; w cap;	000	3	.33	.50	.17
24. Embolus: clockwise; anticlockwise;	000	4	.25	.25	.06
FEMALE SEXUAL CHARACTERS					
25. F genitalia: entelegyne; haplogyne;	DUDNMLPTTLTFCGATGAYAMACHAAEXKCMWCPANWCNAGSAAADHZKXSLNWCNCPAABAWMEKNCXAEV	8	1.00	1.00	1.00
26. Epigynum: pres; abs;	00000011000	1	1.00	1.00	1.00
27. Genital tubercle: abs; pres;	000	1	1.00	1.00	1.00
28. Scape: abs; pres;	0000001000100	8	.12	.79	.09
29. Scape: normal; elongate;	-----0-----0-----0-0000-----00000-000000-0000000000011	1	1.00	1.00	1.00
30. Scape w pocket tip: abs; pres;	-----0---1-----0-----1-0000-----00000-0011111-01101000000100	7	.14	.40	.06
31. Scape: smooth; wrinkled;	-----0-----0-----0-0000-----00010-0101011-110000001111111	6	.16	.61	.10
APPENDAGES					
32. M Coxa + TrIV setae: normal; stout;	DUDNMLPTTLTFCGATGAYAMACHAAEXKCMWCPANWCNAGSAAADHZKXSLNWCNCPAABAWMEKNCXAEV	8	1.00	1.00	1.00
33. Coxa I hook: abs; pres;	0000000000-00	1	1.00	1.00	1.00
34. Femur II w groove: abs; pres;	000	6	.16	.79	.13
35. Femur IV trichobothria: abs; pres;	000	6	.16	.79	.13
36. Pat-tibial autoepaay: abs; pres;	01000011000	2	.50	.66	.33
37. MtIV trichobothria: 0 or 1; many;	000	1	1.00	1.00	1.00
38. Tibia-Metatarsus: norm; flattened;	000	8	.12	.41	.05
39. Serrate accessory claw setae: s; p;	011	3	.33	.00	.00
40. Sustentaculum: abs; pres;	000	8	.12	.74	.08
CEPHALOTHORAX					
41. Carapace: hirsute; glabrous;	DUDNMLPTTLTFCGATGAYAMACHAAEXKCMWCPANWCNAGSAAADHZKXSLNWCNCPAABAWMEKNCXAEV	8	1.00	1.00	1.00
42. F carapace shape: L>W; W2L;	000101111111000000000011111111100000001010000000100000000000000	7	.14	.72	.09
43. M carapace shape: oval; Gast; wide;	000000000000110101100	3	.33	.71	.14
44. Cheliceral margin: smooth; strid;	00000000001110221202200	6	.33	.50	.25
45. Endite tooth: abs; pres;	0000000011000	1	1.00	1.00	1.00
46. Clypeal tooth: abs; pres;	000	4	.25	.68	.22
47. F Cephalon: norm; enlarged;	000	2	.50	.00	.00
48. Cephalon height: normal; high;	00001000010000111	2	.50	.92	1.00
EYES					
49. Anterior: Posterior MOA: S1; >1;	DUDNMLPTTLTFCGATGAYAMACHAAEXKCMWCPANWCNAGSAAADHZKXSLNWCNCPAABAWMEKNCXAEV	8	1.00	1.00	1.00
50. Lat.-median eye separation: <1; >1;	000	8	.12	.68	.09
	000000000000111	6	.16	.81	.14

[continued overleaf]

novel condition had been noted in a particular taxon, we included it and attempted to score the character across all taxa in the matrix. We included somatic morphology, genitalia and behaviour (see character descriptions), and have added a substantial number of new characters. The data for this analysis were compiled mainly from our own observations, but we used the literature extensively to check observations, and occasionally as the sole source, especially where behavioral or other characters from living animals were concerned. In those cases where information was taken from the literature, a reference is given to the paper and a figure, if relevant. Illustrations for all morphological characters are either included here, or a figure is referenced. Brief descriptions of behavioral characters are given along with references to original or synthetic literature sources. All literature information on morphology was checked on specimens. In many cases we provide original illustrations to better explain character states. Since the definitions of characters may vary between authors and sometimes also between different papers of the same author, we established a definition of each character and then scored the characters for the exemplar taxa.

Over the course of the entire study, we scored more than 106 characters, and considered several dozen more, for the 70 taxa. Twenty-four of the former characters were ultimately discarded for various reasons: some turned out to be autapomorphies in the context of the taxa chosen; others because it was impossible to formulate discrete, objectively defined, informative character states (for example, whether male or female lateral eyes were on 'tubercles' or not, whether the orb-web was 'horizontal' or 'vertical', or the number of tubercles on the female abdomen); others were subsumed into unordered multistate characters that remained in the matrix (for example, the presence of stout setae on the femoral tubercle of the male palp (3) as opposed to their number).

Several of the excluded characters merit additional comment. The form of the paracymbium on the male palp has been much used in araneoid systematics (Coddington & Levi (1991) and authors cited therein). At various times during the course of this study we recognized up to seven states of paracymbial form. Hormiga *et al.* (1995) accepted seven states in a smaller variety of taxa. However, even this large number of states does not adequately capture the real variation. Among gasteracanthines, *Zygiella*, *Micrathena*, *Arkys*, and tetragnathids, to name only a few, there is substantial variation in paracymbial form. Many of the variant states are autapomorphic and cannot group taxa unless embedded in a *a priori* transformation series (i.e. an ordered character). In the end, we decided that variation in paracymbial structure (but not absence versus presence) was too great at this cladistic level to code informatively.

Selected 'ratio' characters were excluded because the variation was so nearly continuous among the taxa scored that definition of discrete states became arbitrary (Atchley, Gaskins & Anderson, 1976; Atchley & Anderson, 1978). Examples included clypeal height (relative to an anterior median eye diameter), first versus fourth femur length, and the separation of lateral eyes relative to an eye radius.

A few characters were excluded because the derived conditions were not arguably homologous. Thus *Eustala*, *Metazygia*, *Mangora*, and *Larimia* all have a 'high' cephalothorax in one way or another, but we decided that the similarity between the conditions was not sufficiently detailed to hypothesize homology. *Nephila* and *Nephilengys* share the derived orientation of the embolus at 90° to the tegulum (Hormiga *et al.*, 1995), but embolic orientation varies widely within Araneidae, and is not likely to be homologous to the tetragnathid condition.

Finally, several behavioral characters were excluded because reliable information was available for very few taxa and because states could not be defined unambiguously. These included presence or absence of an exclusively diurnal habit, whether animals rested at the hub or away from it, the manner of prey wrapping (if any) during the attack, presence/absence of silk globs (distinct from stabilimenta); and presence/absence of stabilimenta. The remaining 82 characters comprised 31 genital, 42 somatic, and 9 behavioral characters. The character matrix includes 11 multistate characters (3, 5, 43, 53, 57, 59, 65, 71, 74, 76, and 78), for a total of 89 informative comparisons (not counting the autapomorphic states within multistate characters), all of which we ultimately elected to analyse as unordered. If we felt strongly that characters should be ordered, we used additive binary coding to imply the transformation series. Throughout the text, references to figures from other papers are noted in lower case (e.g. fig.), whereas references to figures herein are capitalized (e.g. Fig.). Abbreviations used in figures and tables appear in the respective legends.

Analysis

We used Hennig86 version 1.5 (Farris, 1988), NONA version 1.15 (32 bit) (Goloboff, 1993a), Pee-Wee version 2.15 (Goloboff, 1993b), and PAUP version 3.1.1 (Swofford, 1993) to analyse the data matrix for heuristic solutions. We ran the data hundreds of times over the course of the analysis. We used MacClade, version 3.0 (Maddison & Maddison, 1992) and Clados version 1.2 (Nixon, 1992) to analyse and optimize characters and to supplement the phylogenetic analysis. In our experience, although Hennig86 is now the oldest phylogenetic software program in widespread use, it remains the fastest at finding most parsimonious trees (the '**t; bb***' option is particularly effective). It is thus ideal for quick manipulations and searches if its capacity is not exceeded. The tree buffer overflows at about 1350 trees for data sets of this size, and the variety of search, diagnosis and tree manipulation options is limited. Starting points for searches cannot be truly randomized, which makes finding tree islands difficult. An irreplaceable feature of Hennig86 is its tolerance for variant file formats (e.g. name length, unmatched parentheses, tree files denoted by taxon number or name, etc.). Hennig86 was often an essential bridge to translate files between PAUP, MacClade, Clados, and NONA.

NONA version 1.15 is only slightly slower than Hennig86, is more effective at handling large numbers of trees, and offers more diagnostic options and search strategies. Simply for finding most parsimonious trees, we found that NONA was usually effective and fast. NONA adopts a unique (and in some ways preferable) definition of character support that affects how treefiles output by Hennig86 and PAUP are interpreted and displayed. NONA applies user-specified definitions of character support when interpreting treefiles, so that branches specified in treefiles may or may not be resolved. The lack of a common convention between all three tree-finding programs makes it difficult to check results between programs or to use NONA's tree manipulation without inadvertently changing the trees themselves.

PAUP 3.1.1. is significantly slower than the DOS software packages mentioned above. However, it has some unique features and it is exceptionally easy to use. Its implementation of constraint trees is easy to use and filtering (especially of compatible

polytomous trees) is critical. NONA can specify constraint trees, but only specifying all involved node numbers.

In sum, all of the currently available packages have their strengths and in analysing this large data set, we found all of them to be indispensable at times. We would also advise caution in accepting complex phylogenetic results from a large analysis that had not been checked in multiple programs to detect the problems discussed below.

Search strategies

In Hennig86 we used the '**t; bb***' option most frequently, but occasionally the '**m*; bb***' recovered trees the former strategy overlooked. In PAUP 3.1.1 we used the heuristic method and all available addition sequence options ('**as is**', '**closest**', '**simple**' and '**random**'). '**Random**' addition sequence was used to shuffle the input order of taxa a number of times to search for different 'islands' of trees. In NONA and Pee-Wee we used the '**empezar**', '**max***', and various settings of '**mult***' (the random addition sequences subjected to tree-bisection and reconnection (TBR) branch swapping) under both '**amb-**' and '**amb=**' options. Taxon input order (or equivalently, addition sequences) had a major effect on the number and length of trees, especially in those programs unable to randomize input order of taxa.

In the case of multiple equally parsimonious trees, strict consensus trees were calculated in the various programs. Such trees are of limited value in understanding the causes of multiple trees since they collapse topological structure present in all trees if one or more taxa jumped cross several nodes. This quirky behaviour of consensus procedures has been known for some time (reviewed in Wilkinson, 1994), but methods to summarize differences among most parsimonious trees that reflect topology unambiguously are unavailable. For such purposes, strict consensus trees are a poor choice since they can fail to report real congruence.

Criteria of cladistic support

Although perhaps not widely appreciated, all the above software packages will report topologies that cannot be supported by data simultaneously at all nodes (zero-length branches). In our view, legitimate phylogenetic hypotheses must have at least one demonstrable character change at every node simultaneously; all monophyletic groups must be supported by evidence (Coddington & Scharff, 1995). Topologies that do not meet this criterion are rejected. At present, such topologies can only be detected by examining individually every topology in the solution set. If not discarded, such illegitimate topologies help to obscure valid topologies, and bias operations involving sets of trees, such as consensus procedures or successive weighting procedures. Missing data (Platnick *et al.*, 1991) exacerbate the problem of zero-length branches, but zero-length branches can occur even when matrices have no missing entries (Coddington & Scharff, 1995; Wilkinson, 1995). Character optimizations must be carefully checked to ensure that data do in fact support each node on a diagnosed tree. Unfortunately, in a large set of most parsimonious trees there is, again, no fast way to detect topologies unsupported by any conceivable character change.

Criteria for tree selection

Although our fundamental goal in this analysis was to investigate the subfamily phylogenetic structure of Araneidae, we also wanted to optimize characters on a tree to investigate character evolution and homology hypotheses. When the solution set contains multiple most parsimonious trees, this requires selecting one or a few topologies that could be thoroughly analysed, proposed as a maximally predictive and testable basis for future work, and used to examine character evolution.

Our first criteria for tree selection were parsimony (shortest length trees), and full support at all nodes. When more than one shortest tree resulted and the trees in the solution set varied in resolution, we reduced the number of trees to be considered by rejecting polytomous trees (Coddington & Scharff, 1996). Under the 'soft' interpretation of polytomies (i.e. lack of resolution is artificial rather than simultaneous cladogenesis, Maddison, 1989), there seems to be little reason to consider polytomous topologies if more resolved solutions are available. Lack of resolution in araneid phylogeny at this point is more likely due to problems in data quantity and quality, and thus the 'soft' polytomy interpretation is appropriate. Most resolved most parsimonious trees contain more phylogenetic hypotheses and detect more monophyletic groups; they are more testable and have greater information content.

We also find relative informativeness of characters as identified by successive weighting a useful criterion in this sort of phylogenetic analysis. Successive character weighting (Farris, 1969; Carpenter, 1988) emphasizes the more consistent characters. These characters agree among themselves and thus with the initial heuristic cladograms. It reduces the influence of the most homoplasious characters. We compared the results of equally weighted and successively weighted analyses and used the latter to prefer topologies among the former when choice was possible.

Finally we considered the implications of trees fulfilling the above criteria for character evolution. In general we preferred trees maximizing homology of complex characters; secondary loss of complex features is a better explanation than parallel gain. Even very similar trees implied different character change reconstructions, and thus some trees could be preferred over others on this basis. Trees containing branches supportable only by speculative guesses about missing entries were also rejected in comparison to trees supported by observed data.

All of these criteria are heuristic and may be mainly applicable to studies of large, poorly known groups when one is seeking initial estimates of phylogenetic structure, and that result in many most parsimonious trees. Given that Araneidae have never been the subject of a detailed and well-founded phylogenetic analysis, we felt that phylogenetic hypotheses meeting these criteria would make the greatest contribution.

In summary, the strategy we found most effective for dealing with this large data set was to: (1) find all most parsimonious trees using a variety of programs and options; (2) eliminate polytomous topologies with filters and by inspection; (3) eliminate trees containing zero-length branches; (4) discriminate among most parsimonious trees with successive character weighting (repeating steps 1–2 at each iteration); and (5) select topologies that maximized homology rather than convergence in complex characters, and (6) were supported by observed data at all nodes.

CHARACTER DESCRIPTIONS

Below we describe all characters used in the analysis. We followed the following format for character descriptions, 'Character name: (0) state; (1) state; (2) state;' etc.

A colon separates the name of the character from its states, with states separated from each other by semicolons. States are listed in the numerical order of the digits assigned to them, and these digits are the codes in Table 3.

The problem of linking character concepts in phylogenetics to empirical observations is logically similar to the problem of linking names to organisms in taxonomy. The method of 'type' specimens solves the problem in taxonomy, and a similar notion of 'type' character states could be fruitfully applied in cladistics. By citing specific taxa we define character states ostensibly rather than with words. For every character, we mention taxa that exemplify the character concept so that other workers can observe the state directly rather than relying solely on our verbal descriptions. Explanation of states and comments on issues of coding particular taxa follow.

Male sexual characters

Character 1. Male tibia of leg II: (0) normal; (1) modified. When modified, the tibiae may be sinuate (e.g. *Eriophora ravilla*, Fig. 1) or provided with a characteristic prong (e.g. *Verrucosa arenata*, Fig. 2—arrow; Levi, 1976, fig. 7).

Character 2. Male leg II tibial macrosetae: (0) similar to those on tibia I; (1) stronger and more robust. The macrosetae on tibia II are stronger than those of tibia I in some males (Grasshoff, 1968, fig. 17; e.g. *Araneus diadematus*; Fig. 3).

Character 3. Male palpal femur with tubercle: (0) absent; (1); present; (2) with macrosetae. The male palpal femora may be provided with a proximal ventral tubercle. The tubercle may have macrosetae (Emerit, 1974, fig. 4c, d; e.g. *Augusta glyphica*, Fig. 4—arrow).

Character 4. Male palpal patellae with macrosetae: (0) absent; (1) present. Patella with one or more long, strong macrosetae (e.g. *Metepieira labyrinthica*, Fig. 5).

Character 5. Cymbium; (0) dorsal; (1) mesal; (2) lateral. The orientation of the cymbium to the bulb of the male palp is twisted, and in dorsal view the cymbium is mesal to the bulb and the sclerites face laterally (Levi, 1983: 251, fig. 8; e.g. *Cyclosa conica*, Fig. 6—arrow, a) or the cymbium is lateral to the bulb and the sclerites face mesally (e.g. *Dictyna arundinacea*, Fig. 7—arrow).

Character 6. Paracymbium on male palp: (0) absent; (1) present. Cymbium of the male palp provided with a proximal branch on the ectal margin (e.g. *Araneus diadematus*; Fig. 8—pc). The homology of the theridiid 'paracymbium' with that of other araneoids is increasingly questionable. Following Griswold *et al.* (in press), we code it as absent.

Character 7. Globular tegulum: (0) absent; (1) present. The tegulum is smooth, globular to almost spherical in *Pachygnatha* (Levi, 1980b, figs. 174, 175, 177) and *Tetragnatha* (Levi, 1981, figs. 20, 32, 33; e.g. *Tetragnatha laboriosa*, Fig. 9—t).

Character 8. Shape of male palpal conductor: (0) entire; (1) with lobe. The conductor of the male palp is normally a single outgrowth from the tegulum (sclerotized or membranous). In some taxa, the conductor is provided with a proximal lobe of variable shape (e.g. *Micrathena*, in Levi, 1985, figs 6, 9; e.g. *Verrucosa arenata*, Fig. 10—arrow).

Character 9. Conductor wraps embolus: (0) absent; (1) present. The embolus is apically placed and wrapped together with the conductor in all the tetragnathids

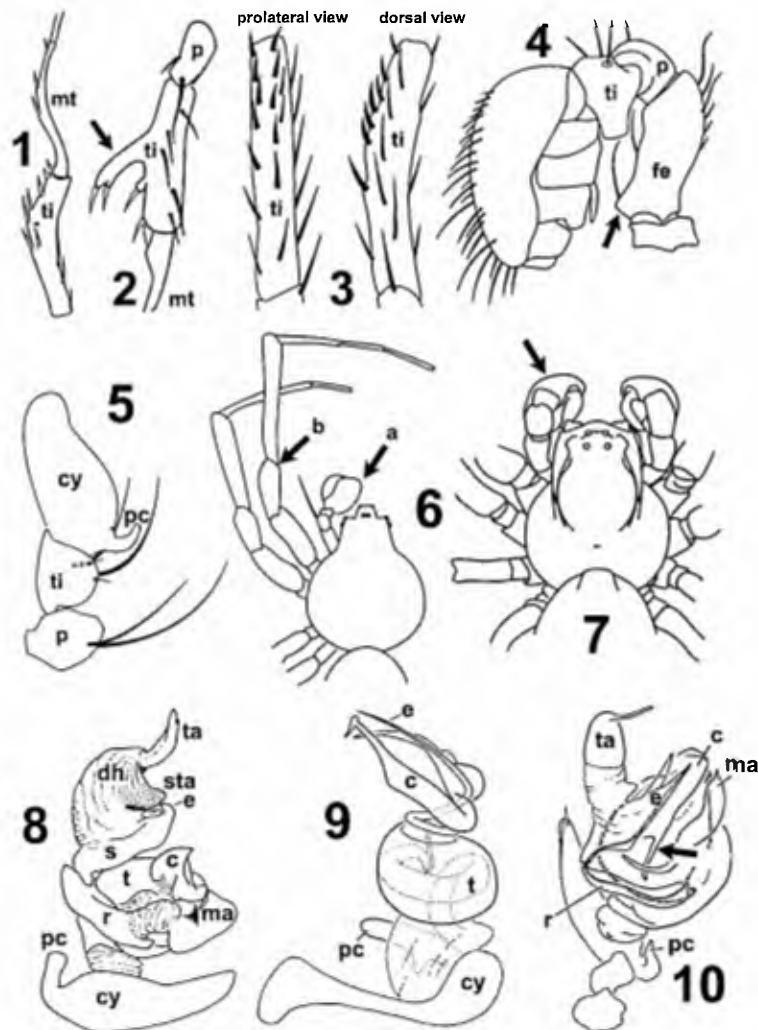

Figures 1–10. Fig. 1. *Eriophora ravilla*, male, showing sinuate tibia II (after Levi, 1970, fig. 8). Fig. 2. *Verrucosa arenata*, male, showing prong on tibia II (arrow) (after Levi, 1976, fig. 7). Fig. 3. *Araneus diadematus*, male, showing strong macrosetae on tibia II (after Grasshoff, 1968, fig. 17). Fig. 4. *Augusta glyphica*, male palp with tubercle (arrow) and macrosetae (after Emerit, 1974, fig. 4). Fig. 5. *Metepieira labyrinthica*, male palp with cymbium, tibia and patella, showing macrosetae on palpal patella (after Levi, 1977a, fig. 8). Fig. 6. *Cyclosa conica*, male spider, dorsal view, showing mesal position of cymbium (arrow a) and location of patellar-tibial joint (arrow b) (after Levi, 1977b, fig. 12). Fig. 7. *Dictyna arundinacea*, male spider, dorsal view, showing lateral position of cymbium (arrow). Fig. 8. *Araneus diadematus*, male palp, expanded, showing cymbium, paracymbium, stipes, median apophysis, tegulum, embolus, conductor, terminal apophysis, subterminal apophysis, distal hematodocha, and radix (after Grasshoff, 1968, fig. 33). Fig. 9. *Tetragnatha laboriosa*, left palp, expanded, showing globular tegulum and wrapped embolus (after Levi, 1981, fig. 20). Fig. 10. *Verrucosa arenata*, left palp, expanded, showing median apophysis and proximal lobe on conductor (arrow) (after Levi, 1976, fig. 9). Abbreviations: c = conductor, cy = cymbium, dh = distal hematodocha, e = embolus, fe = femur, ma = median apophysis, mt = metatarsus, p = patella, pc = paracymbium, r = radix, s = stipes, sta = subterminal apophysis, t = tegulum, ta = terminal apophysis, ti = tibia.

included in this study (Coddington, 1990a, figs 49–51; e.g. *Tetragnatha laboriosa*, Fig. 9–c, e).

Character 10. Male palp with a median apophysis: (0) present; (1) absent. Most entelegyne spiders have two tegular apophyses (conductor and median apophysis) and the presence of a median apophysis within araneoids is probably primitive (Coddington, 1990), although as more lineages are studied, the situation becomes less and less clear (Griswold *et al.*, in press). A median apophysis is absent in linyphiids, deinopids, in the araneid genera *Witica* and *Mecynogea* (Levi, 1980b: 11, fig. 15), and in tetragnathids (e.g. *Tetragnatha laboriosa*, Fig. 9, nephilines, and *Meta menardi*, Fig. 11).

Character 11. Median apophysis of male palp with bifid prong proximally: (0) absent; (1) present. The shape of the median apophysis in araneids is diverse, but not easily construed as a small number of mutually exclusive alternatives. However, the median apophysis of *Kaira*, *Metepeira*, *Aculepeira* and *Araneus* is provided with a distinctive bifid prong (Levi, 1977a, figs 26, 127–129; Levi, 1991, fig. 15; e.g. *Aculepeira carbonoides*, Fig. 12–arrow).

Character 12. Median apophysis of male palp with a threadlike spur: (0) absent; (1) present. *Argiope* and *Neogea* are provided with a distinctive threadlike spur on the median apophysis (e.g. *Argiope lobata*, Fig. 13–arrow), and the form in *Gea* has been proposed as homologous (Levi, 1983, fig. 13). A somewhat similar threadlike spur is present in the *Micrathena gracilis* species group (Levi, 1985, figs 768, 772) but does not seem general enough within micrathenines to consider homology.

Character 13. Median apophysis with transparent flap: (0) absent; (1) present. The median apophysis of *Augusta* and *Gastroxya* is provided with a transparent triangular flap not seen in any other araneids (e.g. *Gastroxya schoutedeni*, Fig. 14–arrow).

Character 14. Median apophysis large with fork: (0) absent; (1) present. The median apophysis is large and provided with a distal fork in *Acacesia* and *Wixia* (Levi, 1976, figs. 82, 83, 96, 97; Glueck, 1993, figs 1, 2; e.g. *Acacesia hamata*, Fig. 15–arrow).

Character 15. Median apophysis anterior margin: (0) smooth; (1) toothed. Anterior margin of median apophysis with small teeth (e.g. *Kaira alba*, Levi, 1977a, figs 127, 128; Fig. 16–arrow, and *Aculepeira packardii*, Levi, 1977a, figs 159, 160).

Character 16. Radix: (0) absent; (1) present. In most araneoids, the embolus inserts directly on the tegulum. In some araneoids an intercalary sclerite, the radix, is present between the tegulum and the embolus, and the sperm duct runs from the tegulum through the radix to the embolus proper (e.g. *Araneus diadematus*, Fig. 8–r; *Eriophora*, Fig. 18–r). The theridiid ‘radix’ is not a homolog of the araneid radix (Coddington, 1990a).

Character 17. Distal hematodocha: (0) absent; (1) present. The term ‘distal hematodocha’ should probably be restricted to the saclike, membranous structure located distal to the radix, and connected to the stipes and/or the terminal apophysis (*sensu* Comstock, 1910: 177, figs 13, 14; e.g. *Araneus diadematus*, Fig. 8–dh). ‘Distal hematodocha’ has also been applied to the saclike structure situated between the embolic division and the tegulum in araneids and other spiders, but is not directly homologous to the hematodocha within the embolic division proper.

Character 18. Paramedian apophysis: (0) absent; (1) present. Most araneids have two tegular apophyses (conductor and median apophysis) other than the embolus. A few genera have a third apophysis called the paramedian apophysis, though it varies in where it inserts on the tegulum (e.g. *Gasteracantha theisi*, Fig. 17–arrow; *Eriophora*; Fig. 18–pma).

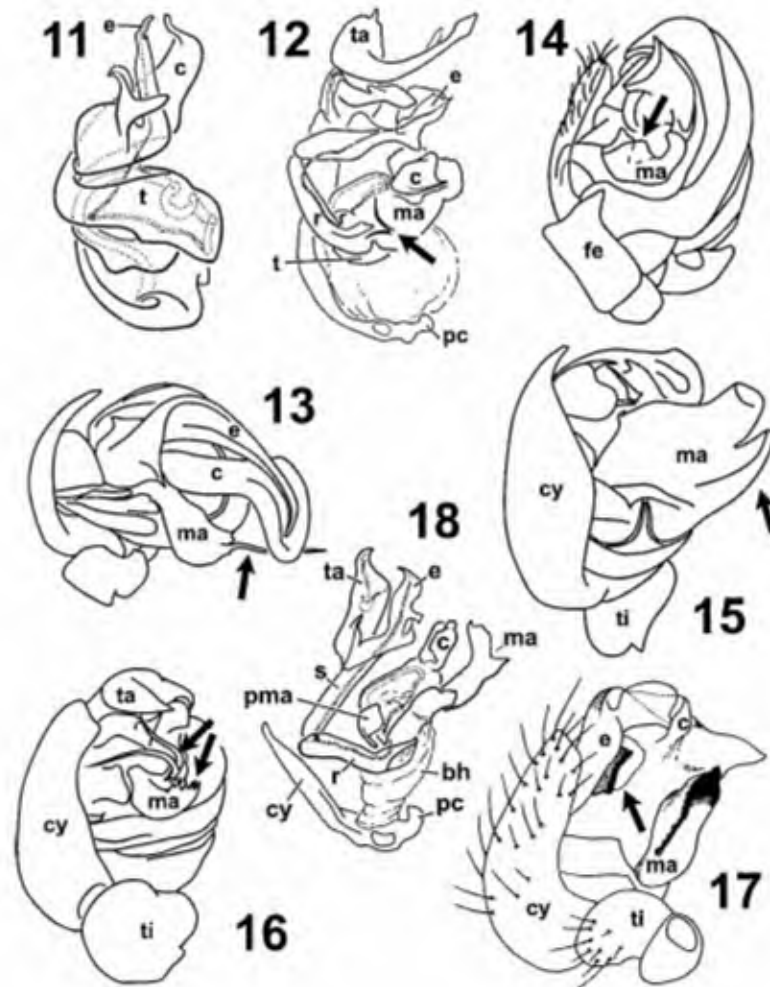

Figures 11–18. Fig. 11. *Meta menardi*, left palp, expanded view (after Levi, 1980b, fig. 125). Fig. 12. *Aculepeira carbonoides*, left palp, expanded, showing paracymbium and bifid prong on the median apophysis (arrow) (after Levi, 1977a, fig. 173). Fig. 13. *Argiope lobata*, left palp, mesal view, showing median apophysis with threadlike spur (arrow) (after Levi, 1983, fig. 97). Fig. 14. *Gastrosya schoutedeni*, left palp, mesal view, showing transparent flap on median apophysis (arrow). Fig. 15. *Acaesia hamata*, male palp, mesal view, showing median apophysis with a distal fork (arrow) (after Levi, 1976, fig. 82). Fig. 16. *Kaira alba*, left palp, mesal view, showing small teeth and bifid prong of median apophysis (arrows) (after Levi, 1977a, fig. 127). Fig. 17. *Gasteracantha theisi*, male palp, showing paramedian apophysis (arrow). Fig. 18. *Eriophora* sp., male, left palp, expanded, showing cymbium, paracymbium, radix, stipes, terminal apophysis, embolus, conductor, median apophysis, paramedian apophysis, and basal haematodocha (after Levi, 1970, fig. 2). Abbreviations: bh = basal hematodocha, c = conductor, cy = cymbium, e = embolus, fe = femur, ma = median apophysis, pc = paracymbium, pma = paramedian apophysis, r = radix, s = stipes, t = tegulum, ta = terminal apophysis, ti = tibia.

Character 19. Stipes: (0) absent; (1) present. A separate sclerite, the stipes (s), is present between the radix (r) and the embolus (e) on the male palp (e.g. *Eriophora*, Fig. 18–s).

Character 20. Subterminal apophysis: (0) absent; (1) present. A sclerite that inserts

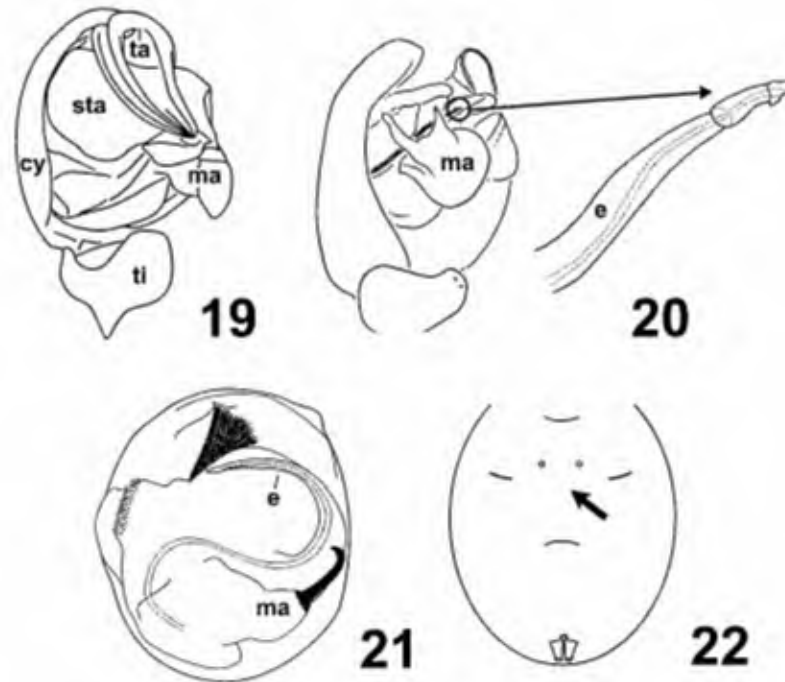

Figures 19–22. Fig. 19. *Metazygia wittfeldae*, male palp, mesal view, showing bubble-shaped subterminal apophysis (sta) (after Levi, 1977b, fig. 101). Fig. 20. *Larinia borealis*, left palpus, showing embolus cap (arrow) (after Levi, 1975, figs. 13 and 32). Fig. 21. *Cyrtophora citricola*, left palp, lateral view, showing anticlockwise direction of embolus. Fig. 22. *Pachygnatha fuscillata*, female abdomen, ventral view, showing the lack of external epigyne in adult female (after Levi, 1980a, fig. 168). Abbreviations: cy = cymbium, e = embolus, ma = median apophysis, sta = subterminal apophysis, ti = tibia.

on the embolus via a distal hematodocha and is not terminal has been called the subterminal apophysis (Grasshoff, 1968, fig. 33; e.g. *Araneus diadematus*, Fig. 8–sta). Several sclerites insert on the embolus via a hematodocha, and the homology of these structures is debatable. If two or more sclerites insert on the embolus, traditionally the most terminal is the ‘terminal apophysis’ (see 22) and one of the remaining sclerites is the ‘subterminal apophysis’.

Character 21. Subterminal apophysis: (0) normal; (1) bubble-shaped. The subterminal apophysis of the male palp is inflated, transparent and bubble-like in *Eustala* and *Metazygia* (e.g. *Eustala anastera*, Levi, 1977b, figs. 215, 232 and *Metazygia wittfeldae*, Levi, 1977b, figs 101–103; Fig. 19–sta).

Character 22. Terminal apophysis: (0) absent; (1) present. The terminal apophysis is the most apical sclerite that inserts on the embolus via a distal hematodocha (see note for 20; e.g. *Araneus diadematus*, Fig. 8–ta and *Eriophora*, Fig. 18–ta).

Character 23. Tip of male palpal embolus: (0) simple; (1) with cap. The tip of the embolus is modified to break off during mating and stay behind in the female copulatory duct in *Larinia* (Grasshoff, 1970, fig. 1f), *Metepeira*, *Araneus*, *Aculepeira* and *Argiope* (Levi, 1970, 1975, 1977a and 1991), among the genera included here. The embolus cap can be observed in virgin males (e.g. *Larinia borealis*, Fig. 20–arrow).

Character 24. Embolus, direction of curve (lateral view, left palp): (0) clockwise; (1) anticlockwise. In most araneoids, the embolus of the non-expanded palp runs in a

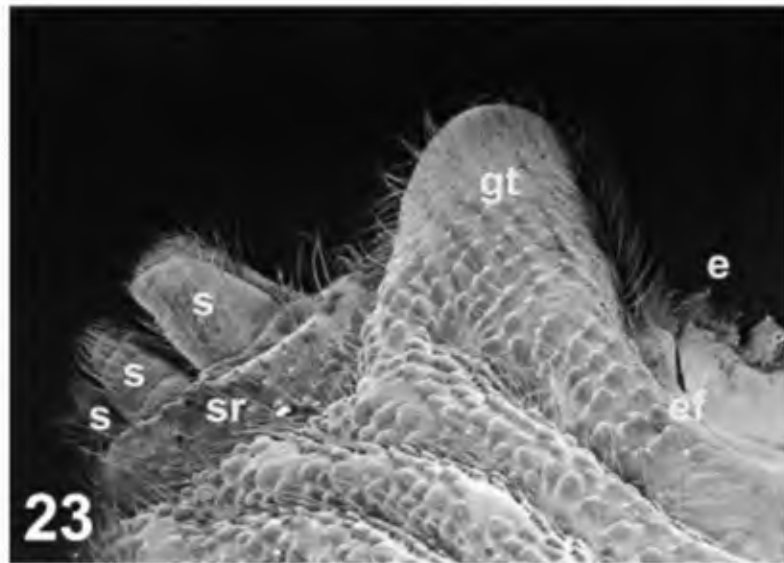

Figure 23. *Gasteracantha cancriformis*, female abdomen, lateral view, showing spinneret (s), ring around spinnerets (sr), epigyne (e), epigastric furrow (ef), and genital tubercle (gt).

clockwise direction. The embolus (e) runs in a anticlockwise direction in *Mecynogea* (Levi, 1980b, fig. 14), *Cyrtophora citricola*, Fig. 21, *Witica* (Levi, 1986a, figs. 9 and 14) and *Zygiella* (Levi, 1974a, fig. 6).

Female sexual characters

Character 25. Female genitalia: (0) entelegyne; (1) haplogyne. Entelegyne female genitalia have fertilization ducts that connect the spermathecae to the gonoduct independently of copulatory ducts opening to the ventral body wall; haplogyne female genitalia lack such fertilizations duct. The haplogyne condition is present in *Tetragnatha*, *Pachygnatha* (Levi, 1981, fig. 27; Levi, 1980b, figs 181, 182) and *Glenognatha* (Hormiga *et al.*, 1995, Table 1). Since most of the outgroups (Entelegynae and deinopids) are entelegyne, the various araneoid haplogyne conditions are probably secondary. See discussion in Platnick (1991), Coddington & Levi (1991), and Griswold *et al.* (in press).

Character 26. Epigynum: (0) present; (1) absent. External structures of the female genitalia are absent in *Pachygnatha* and *Tetragnatha* (e.g. *Pachygnatha clercki*, Levi, 1980b, figs 229, 233; Fig. 22).

Character 27. Genital tubercle; (0) absent; (1) present. The female abdomen may have a sclerotized tubercle between the epigynum and the spinnerets (e.g. *Gasteracantha cancriformis*; Fig. 23–gt).

Character 28. Scape: (0) absent; (1) present. The dorsal or ventral wall of the epigynum of many female spiders projects medially as a pointed, or fingerlike, form. In araneids, the scape arises exclusively from the ventral wall. The shape and

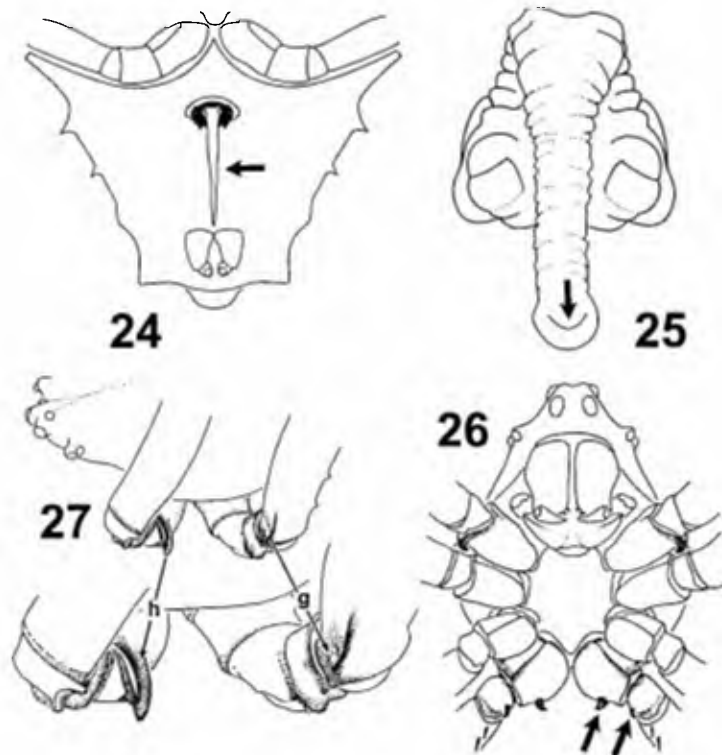

Figures 24–27. Fig. 24. *Verrucosa arenata*, female, ventral view, with elongated scape (arrow) (after Levi, 1976, figs 2, 3). Fig. 25. *Araneus diadematus*, female, epigynum with wrinkled scape that is provided with a pocket near the tip (arrow) (after Grasshoff, 1968, fig. 40a). Fig. 26. *Wixia georgia*, showing macrosetae (arrows) on male coxae and trochanter IV. Fig. 27. *Eriophora edax*, male legs I and II, showing coxae I with hook (h) and femora II with groove (g).

morphology of scapes are diverse, and we have adopted a fairly broad definition in order to test its homology (e.g. *Verrucosa arenata*, Fig. 24–arrow).

Character 29. Scape: (0) normal; (1) elongate. The scape is considered elongate if it is more than 5 times longer than the width at base (e.g. *Verrucosa arenata*, Fig. 24–arrow).

Character 30. Scape with pocket near tip: (0) absent; (1) present. The ventral tip of the scape is provided with a pocket (Grasshoff, 1968, fig. 40; e.g. *Araneus diadematus*, Fig. 25–arrow). In some araneids, the median apophysis of the male palp interacts with the pocket tip during mating (Grasshoff, 1968, 1973).

Character 31. Scape of epigynum: (0) smooth; (1) wrinkled. The surface of the scape is clearly wrinkled or annulated in several araneids (Grasshoff, 1968, fig. 40; Levi, 1974b, fig. 8; e.g. *Araneus diadematus*, Fig. 25). Annulated scapes probably are extended (possibly by the male) or inflate during copulation.

Appendages

Character 32. Macrosetae on coxae and trochanter IV of males: (0) normal; (1) stout. In most araneoids, the setae on coxae and trochanter IV are similar to those

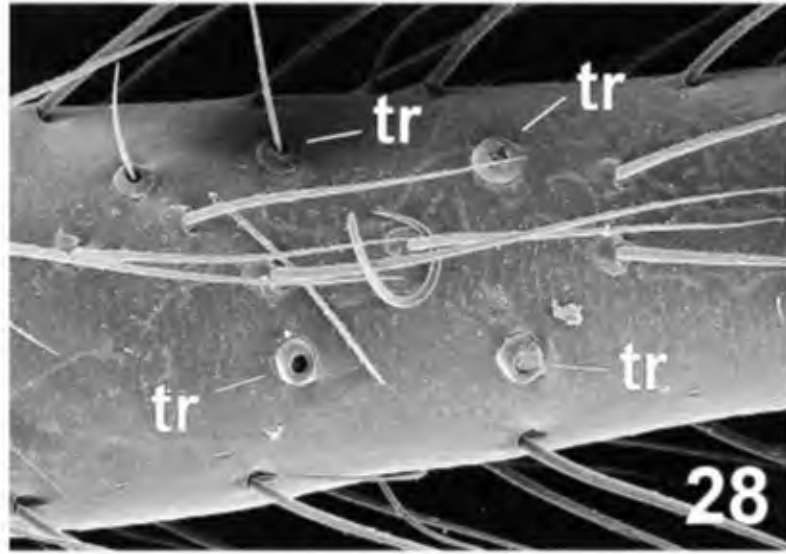

Figure 28. *Gasteracantha geminata*, fourth metatarsus of female, showing trichobothria (tr).

found on the legs and sternum. In some cases coxae IV and trochanters IV are each provided with a short stout macroseta (e.g. *Wixia georgia*, Fig. 26—arrows; *Acacesia*; Levi, 1976, figs. 86, 123). Theridiids lack macrosetae on their coxa (Griswold *et al.*, in press).

Character 33. Coxa I hook: (0) absent; (1) present. Many male araneids lack modifications of coxae I, but some have a prominent retrolateral hook (Fig. 27—h) on the first coxae, which fits into a groove on the second femora (Grasshoff, 1968, fig. 44; e.g. *Eriophora edax*).

Character 34. Femur II with groove: (0) absent; (1) present. Most male araneids do not have any modification of femora II. Some male araneids have a groove on the second femora (Fig. 27—g) that works together with the hooks on coxae I (33) (Grasshoff, 1968, fig. 44; e.g. *Eriophora edax*). Characters 33 and 34 are functionally linked, but together they are a complex feature that probably deserves the extra cladistic weight.

Character 35. Femur IV trichobothria: (0) absent; (1) present. Fourth femora are provided with a number of dorsal trichobothria (e.g. *Leucauge argyra*, Levi, 1980b, fig. 67).

Character 36. Tibial autospasy: (0) absent; (1) present. Tibia of legs detach at a predetermined locus of weakness between tibia and patella (Fig. 6—b illustrates location of detachment zone); e.g. *Lepthyphantes flavipes*; Roth & Roth, 1984). Tibial autospasy is known from linyphiids and pimoids (Hormiga, 1994a, b), but also from the relatively distantly related leptonetids, filistatids and hersiliids.

Character 37. Number of trichobothria on metatarsus IV: (0) 0–1; (1) many. Normally female araneoids have no or one trichobothrium on the metatarsi. Some genera have many. The coding is ambiguous because the number ranges from 0–1 in most genera to 2–3 in *Witica* and *Alpaida* to more than 10 in *Eriophora*, *Caerostris* and *Mastophora* (e.g. *Gasteracantha geminata* as an example of state 1, Fig. 28—tr). We tried various ways to render the continuum discrete, but no method clarified the

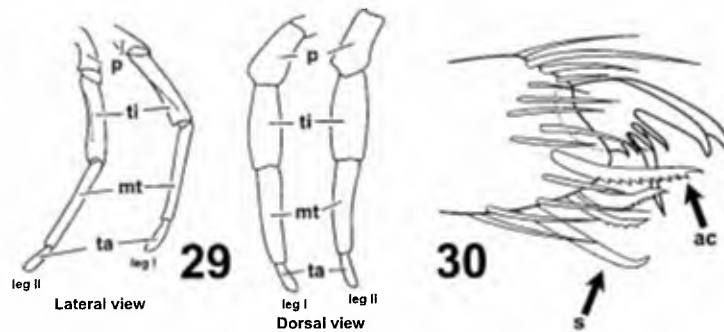

Figures 29–30. *Caerostris* sp., legs I & II, lateral and dorsal views, showing flattened tibiae and metatarsi. Fig. 30. *Larinioides scolopetarius*, distal end of tarsus IV, showing sustentaculum (arrow–s) and serrate accessory claw setae (arrow–ac) (after Kaston, 1948, fig. 815). Abbreviations: ac = accessory claw setae, mt = metatarsus, p = patella, s = sustentaculum, ta = tarsus, ti = tibia.

results, for example by corroborating another character. Ultimately, we decided to include the feature, and simply to contrast the most common (0–1) with the rarer condition (>2).

Character 38. Tibiae and metatarsi: (0) normal; (1) flattened. Tibiae and metatarsi are clearly dorsoventrally flattened in a few araneids (e.g. *Caerostris sexcuspidata*, Fig. 29–ti and mt).

Character 39. Serrate accessory claw setae: (0) absent; (1) present. Orbicularians are equipped with two or more stout, sharply serrate setae at the tarsal tips. Although the character is uninformative in this context, we include it to reveal homoplasy, if any, among araneoids (e.g. *Nuctenea umbratica*, Fig. 30–arrow ac).

Character 40. Sustentaculum: (0) absent; (1) present. The sustentaculum is a thick macroseta with a bent tip, situated below the accessory claws of the fourth tarsi (e.g. *Nuctenea umbratica*, Fig. 30–arrow s). The macroseta was called ‘Sustentaculum’ by Reimoser (1917), and ‘Webestachel’ by Dahl (1912: 502, fig. 27), (Levi, 1985, plate 3, *Microthema mitrata*).

Cephalothorax

Character 41. Carapace: (0) hirsute (Fig. 31); (1) glabrous (Fig. 35). The female carapace may be densely to moderately hirsute, or with few to no setae on the cephalon or along the margin of carapace (e.g. *Encyosaccus sexmaculatus* as representative for state 1).

Character 42. Female carapace shape: (0) longer than wide; (1) wider than long or equal length. The carapace shape of most araneids is longer than wide. Some araneids have a carapace that is almost square-shaped. The carapace of *Aetrocantha falkensteini* (Fig. 31) illustrates the almost square-shaped carapace.

Character 43. Male carapace shape: (0) oval; (1) *Gasteracantha*-like; (2) wide. Most araneoid males have a pear-shaped or oval carapace (araneid-like, Fig. 6). The pear shape may have bulges behind the ocular area (*Gasteracantha*-like; Figs 32, 33; e.g. *Gasteracantha geminata*), or the cephalothorax may be more or less quadrangular rather than pear shaped (e.g. *Isoxya cicatricosa*, Fig. 34).

Character 44. Margin of chelicerae: (0) smooth; (1) with stridulation file. Most



Figure 31. *Aetrocantha falkensteini*, female showing rectangular cephalon and carapace that are as wide as long.

spiders have smooth chelicerae, but the chelicerae of some species (males and females) have horizontal ridges laterally. Such ridges are present in both sexes of pimoids (Hormiga, 1994b) and many linyphiids (e.g. *Lepthyphantes stramencola*, Fig. 35–arrow). Cheliceral stridulating files are a synapomorphy for linyphiids and pimoids (Hormiga, 1993, 1994a, b). Stridulating files on the chelicerae have been reported from a number of other spider families (*loc. cit.*), but they are probably not homologous to those found in linyphiids and pimoids.

Character 45. Endite tooth: (0) absent; (1) present. The endites of most araneids are smooth. Males of some species may have a tooth on the lateral face of the endite, often but not always facing a similar tooth or tubercle on the palpal femur (see 3) (e.g. *Wagneriana tayos*, Fig. 36–arrow).

Character 46. Clypeal tooth of females: (0) absent; (1) present. Margin of clypeus is provided with a ventral tooth (e.g. *Caerostris sexcupidata*, Grasshoff, 1984, figs. 1, 4–5; Fig. 37–arrow).

Character 47. Cephalon of female: (0) normal; (1) enlarged. The cephalon of female can be clearly raised and set off from thorax by constrictions between cephalon and thorax. Cephalon is rectangular in dorsal view, wider than long (e.g. *Aetrocantha falkensteini*; Fig. 31).

Character 48. Female cephalon height: (0) normal; (1) high. Cephalon may be abnormally higher than the thorax (but not rectangular and not clearly set off from thorax as in 47) in several araneid taxa (e.g. *Acanthepeira stellata*, in Levi, 1976, fig. 13).

Eyes

Character 49. Anterior/posterior MOA: (0) <1; (1) >1. This ratio is the separation of anterior median eyes to that of the posterior median eyes, including the eyes

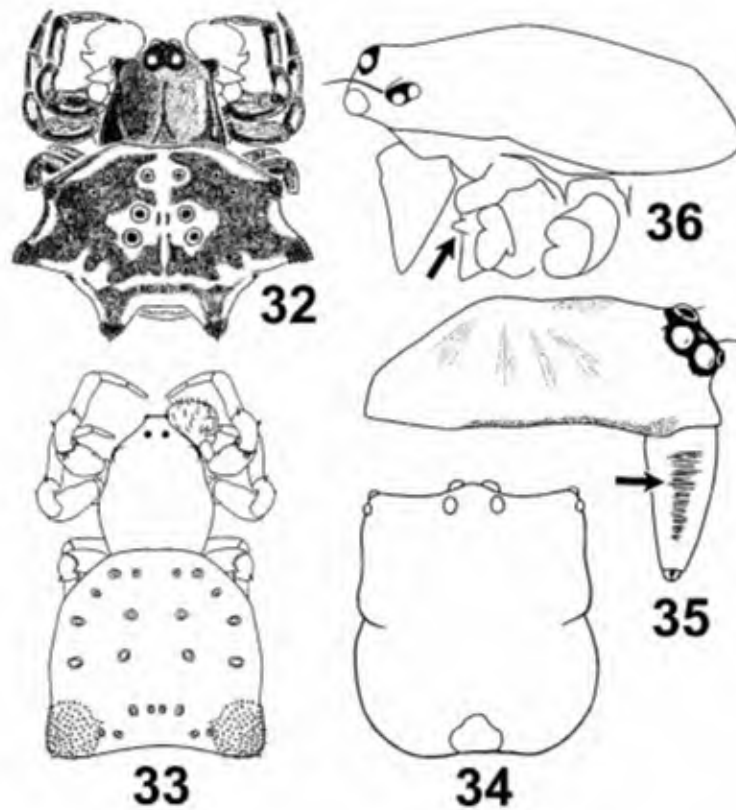

Figures 32–36. *Gasteracantha theisi*, male, dorsal view, showing ‘star shaped’ abdomen and *Gasteracantha*-like carapace. Fig. 33. *Gasteracantha geminata*, male, dorsal view, showing ‘inverted U-shaped’ abdomen and *Gasteracantha*-like carapace. Fig. 34. *Isoxya cicatricosa*, male, dorsal view, with wide cephalothorax. Fig. 35. *Lepthyphantes stramencola*, lateral view of female cephalothorax and chelicerae, showing stridulating file (arrow) (after Scharff, 1990, fig. 108). Fig. 36. *Wageriana tayos*, male, lateral view, showing endite with tooth (after Levi, 1991, fig. 22).

themselves. This character defines the shape of the median ocular area (MOA) as narrower in front or behind (e.g. Figs 6, 37, *Cyclosa conica*, *Caerostris* sp.).

Character 50. LE-ME separation: (0) <1; (1) >1. The distance between the lateral eyes (LE) and the median eyes (ME) are given as the following ratio: distance between LE and ME (at the widest point) divided by the width of the ME ocular area (at the widest point). If the ratio is less than 1, the separation is normal (e.g. *Cyclosa*). If the ratio is more than 1, the separation is wide (e.g. *Isoxya cicatricosa*, Fig. 34). The character measures how far the lateral eye groups are set apart from the median ocular area.

Character 51. Posterior median eyes with canoe tapetum: (0) absent; (1) present. When absent, the tapetum fills the entire eye cup (Foelix, 1992, fig. 66c–pt). When present, the tapetum consist of two lateral walls and a median gap (Foelix, 1992, fig. 66c–ct; Fig. 38–ale), thereby forming a canoe-shape (see also Homann, 1971, fig. 10A) (e.g. *Araneus diadematus*). The presence of a canoe tapetum in *Arkys* and *Archemorus* is debatable. In ten *Arkys* specimens and six *Archemorus* specimens we observed badly deteriorated tapeta in only one specimen of each genus. Homann

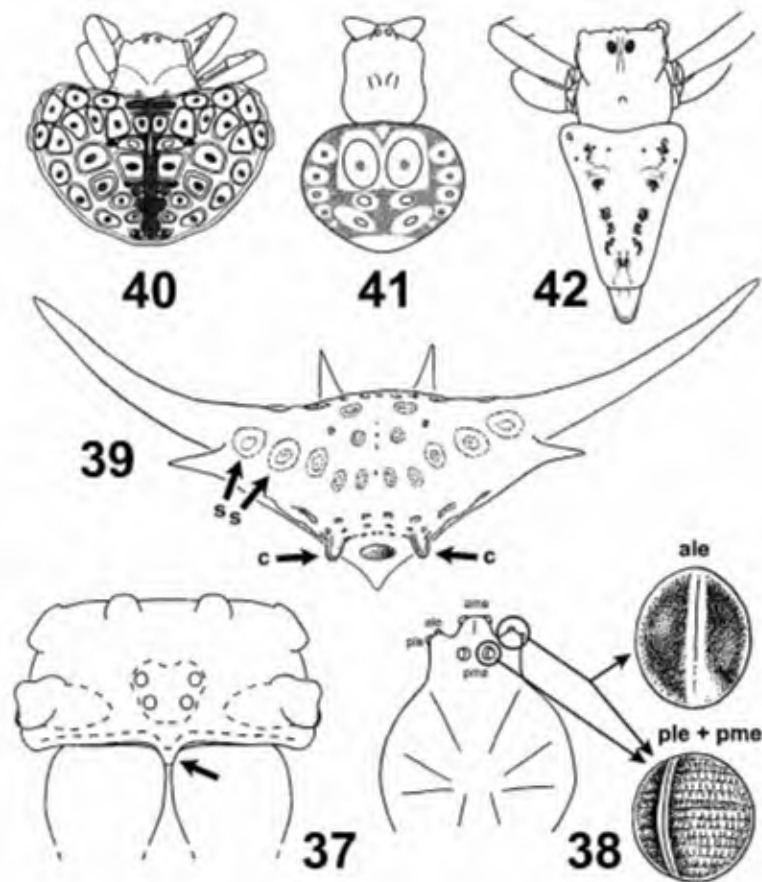

Figures 37–42. Fig. 37. *Caerostris* sp., female carapace, front view, showing clypeal tooth (arrow). Fig. 38. *Argiops picta*, eye region, showing canoe-shaped tapetum reducer to a sliver in posterior median and lateral eyes (pme + ple) and canoe shaped tapetum in anterior lateral eyes (ale) (after Levi, 1983, figs 9, 10, 313 and Homann, 1971, fig. 27). Fig. 39. *Gasteracantha* sp. female abdomen, frontal view, with condyles (arrow-c) and sigillae (arrow-s). Fig. 40. *Augusta glyphica*, male abdomen, dorsal view, showing heart-shaped abdomen. Fig. 41. *Hypognatha scutata*, male abdomen, dorsal view, showing round abdomen. Fig. 42. *Arkys* sp., male abdomen, dorsal view, showing triangular abdomen.

(1971, p. 240) reported rudimentary ('KT rudimentär') canoe-shaped tapetum in *Archemorus*, and Harvey (pers. comm.) reports clearly seeing 'a tapetum' in *Arkys*. The tapetum frequently degrades in museum specimens, and thus it is quite possible that living animals (unavailable to us) have obvious canoe tapeta. Based on the meager observational evidence, we decided to code them as present. If tapetal characters are coded as absent or missing entries for these genera, the cladistic results are the same.

Character 52. Posterior median eyes with narrow tapetum: (0) absent; (1) present. In most araneoids, the posterior median eyes have a full canoe tapetum (the midline or 'keel' of the canoe tapetum bisects the eye cup, and the rhabdome and tapetum are equally displayed on each side). In some araneoids, the canoe tapetum is reduced to a sliver in the posterior median eyes (Levi, 1983: 252, fig. 10; e.g. *Araneus diadematus*,

see Fig. 38–pme for an illustration of a reduced canoe tapetum in *Argiope picta*). See character 51 for comments on *Arkys* and *Archemorus*.

Character 53. Canoe-shaped tapetum of posterior lateral eyes: (0) normal; (1) reduced; (2) absent. A well developed canoe-shaped tapetum in the posterior laterals is widespread among araneoids and is also found in the more distantly related families Agelenidae, Amaurobiidae, and Dictynidae (Homann, 1971; Levi, 1983: 252; Griswold *et al.*, in press). The canoe-shaped tapetum of the posterior laterals is reduced to a narrow slit in *Argiope*, *Neogea*, and *Gea* (Levi, 1983: 252, fig. 9; e.g. *Argiope picta*, Fig. 38–ple) and it is lost in a number of genera (e.g. *Tetragnatha*, Levi, 1981, fig. 22). See character 51 for comments on *Arkys* and *Archemorus*.

Character 54. Posterior row of eyes (dorsal view): (0) straight to recurved; (1) procurved. The posterior row of eyes is procurved in *Argiope*, *Gea* and *Neogea* (Levi, 1983, fig. 52; e.g. *Argiope picta*, Fig. 38).

Abdomen

Character 55. Feathery hairs; (0) absent; (1) present. (e.g. *Deinopis*). Most cribellate spiders have plumose setae (e.g. Figs 52, 61). Araneoids have serrate setae (Figs 68, 72). However, deinopoids and a few other cribellate taxa also have flattened, feathery or feather-like setae, typically on the abdominal surface. Griswold (1993: fig. 75) provides an illustration of typical feathery setae.

Character 56. Abdominal sigillae: (0) absent; (1) present. Dorsum of female abdomen provided with a number of sclerotized discs (muscle attachment sites distinct from the usual apodemes) (e.g. *Gasteracantha cancriformis*, Levi, 1978, fig. 72; Figs. 39, 40).

Character 57. Abdominal sigillae: (0) scattered; (1) 1 row; (2) 2 rows. The sclerotized discs on the dorsum of the female may be scattered (e.g. *Chaetacis aureola*, Levi, 1985, fig. 845), or in one marginal row (e.g. *Gasteracantha cancriformis*, Levi, 1978, fig. 72), or in two marginal rows (e.g. *Gastroxya schoutedeni*, Emerit, 1973, fig. 9; *Augusta glyphica*, Fig. 40).

Character 58. Female abdomen with ventral condyles: (0) absent; (1) present. The female abdomen is provided with two small condyles lateral to the pedicel (e.g. *Gasteracantha*; Fig. 39–arrow c) in Old World gasteracanthines and *Caerostris*. Condyles are absent in the New World genera *Micrathena*, *Chaetacis* and *Xylethrus*.

Character 59. Male abdominal shape: (0) normal; (1) star-shaped; (2) U-shaped; (3) heart-shaped; (4) square; (5) round; (6) triangular. Male abdomens may have three pairs of blunt spines (star-shaped; e.g. *Gasteracantha theisi*, Fig. 32; and *Macracantha arcuata*), or may be horseshoe-shaped (U-shaped; e.g. *Gasteracantha geminata*, Fig. 33), or shaped like a heart (e.g. *Augusta glyphica*, Fig. 40), or square (e.g. *Isoxya tabulata*, Emerit, 1973, fig. 3), or round (e.g. *Hypognatha scutata*, Fig. 41), or triangular (e.g. *Arkys walckenaeri*, Fig. 42). The ‘heart’ and ‘square’ shapes are autapomorphic in this context.

Character 60. Female abdominal shape: (0) longer than wide; (1) wider than long. (e.g. *Gasteracantha cancriformis*, Levi, 1978, fig. 72; Fig. 39).

Character 61. Female/male size ratio: (0) <2 times; (1) >2 times. In most spiders the female is less than twice as big as the male. In others the female is more than twice as big as the male (e.g. *Macracantha arcuata*).

Character 62. Gasteracanthine abdominal spines: (0) absent; (1) present. Female



Figure 43. *Micrathena sagittata*, showing stridulating file on book-lung covers. Abbreviations: e = epigyne, sf = stridulating file.

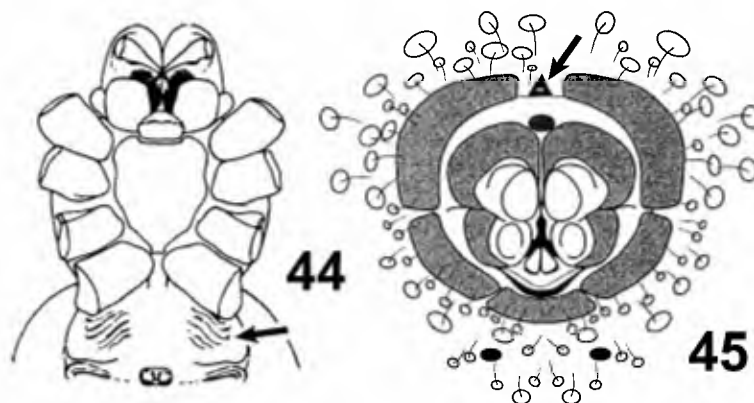

Figures 44–45. Fig. 44. *Araneus* sp., ventral view, prosoma and opisthosoma. The latter with booklung covers, showing grooves (arrow) (after Kaston, 1980, fig. 336). Fig. 45. *Xylethrus superbus*, female abdomen, ventral view, showing tracheal spiracle on one of the sclerites that surround the spinnerets (arrow).

abdomen with three pairs of spines (e.g. *Gasteracantha cancriformis*, Levi, 1978, fig. 72; Fig. 39).

Character 63. Booklung covers of males and females: (0) smooth; (1) with stridulating file. Booklung covers of males and females of *Micrathena* and *Chaetacis* are provided with a stridulatory surface composed of many parallel ridges (Levi, 1985, plate 3; *Micrathena sagittata*, Fig. 43–sf). This must not be confused with the fewer wrinkles or grooves (normally less than 10) often observed on the booklung covers of araneids (see 64).

Character 64. Booklung cover: (0) normal; (1) grooved. Booklung covers on the female abdomen are normally smooth. In some taxa booklung covers have wrinkles/grooves, normally less than 10 (Fig. 44–arrow) (e.g. *Araneus diadematus*).

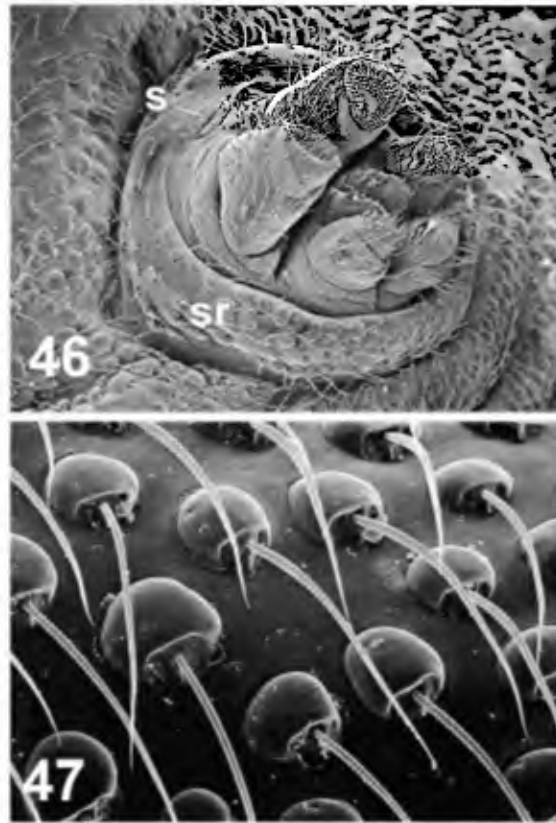

Figures 46–47. Fig. 46. *Gasteracantha geminata*, female abdomen, ventral view, showing spinnerets with solid sclerotized ring (sr) and spiracle (s). Fig. 47. *Aetrocantha falkensteini*, dorsal view, showing ‘gasteracanthine-like macrosetae’ on cephalothorax.

Character 65. Sclerotized ring around spinnerets: (0) absent; (1) with sclerites or plates; (2) with a solid ring. The spinnerets of the female may be surrounded by a number of sclerites, plates, or sclerotized disks (e.g. *Xylethrus superbis*, Fig. 45) or may be surrounded by a solid sclerotized ring (e.g. *Gasteracantha geminata*, Fig. 46–sr). Emerit (1974) studied the ontogeny of the sclerotized ring in *Gasteracantha*, and found a transformation from [ring absent] to [ring composed of five separate sclerites] to [solid ring].

Character 66. Spiracle on female abdomen: (0) unsclerotized; (1) sclerotized. The tracheal spiracle in front of the spinnerets is incorporated in the sclerotized ring (and thereby sclerotized; e.g. *Gasteracantha geminata*, Fig. 46–s) or positioned on the sclerites/plates that surround the spinnerets (e.g. *Xylethrus superbis*, Fig. 45–arrow).

Character 67. Tactile setal bases on carapace and abdomen: (0) normal; (1) gasteracanthine-shaped. Normally the tactile setae insert in a narrow, pocketed socket (*sensu* Foelix, 1982: 71, fig. 55). In gasteracanthines, the socket is broad, flat, and hooded and the setal shape itself is characteristic (Nemenz, 1963: 112, e.g. *Aetrocantha falkensteini*, Fig. 47).

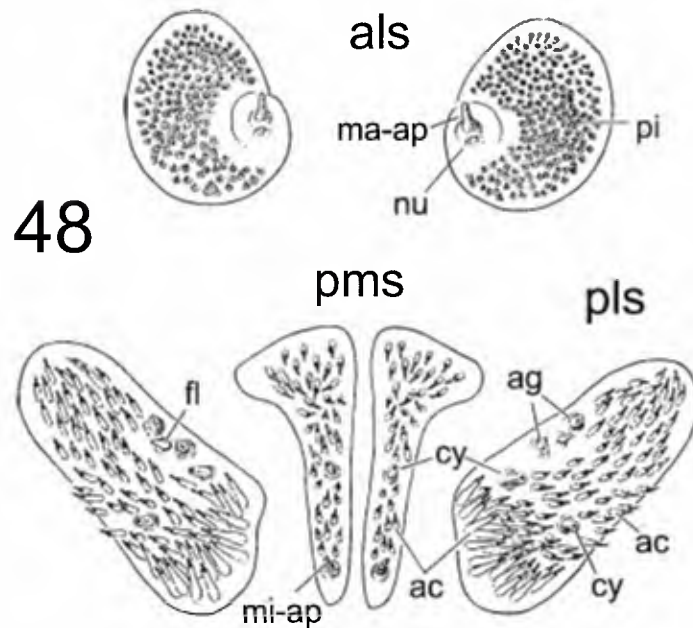

Figure 48. Generalized araneoid spinneret and spigot location (after Coddington, 1989, fig. 1). Abbreviations: ac = aciniform gland spigots, ag = aggregate gland spigots, als = anterior lateral spinnerets, cy = cylindrical gland spigots, fl = flagelliform gland spigots, ma-ap = major ampullate gland spigot, mi-ap = minor ampullate gland spigot, nu = nubbins, pi = piriform gland spigots, pls = posterior lateral spinnerets, pms = posterior median spinnerets.

Spinnerets

See Figure 48 for a generalized illustration of araneoid spinneret and spigot location.

Character 68. Cribellum: (0) present (Fig. 49–crb); (1) absent (Fig. 77–col). The spinning plate in front of the spinnerets is lost (Foelix, 1982, fig. 91a) or transformed into a cololus (e.g. *Theridiosoma gemmosum*, Fig. 77–col).

Character 69. Anterior spinneret piriform bases: (0) normal (Fig. 66–pi); (1) reduced (Fig. 54–pi). (e.g. *Theridula*, *Frontinella*, Coddington (1989: figs. 31, 39), and *Enoplognatha ovata*, Fig. 54–pi). These theridiid codings are used for *Theridion*.

Character 70. Reduced piriform fields: (0) absent (Fig. 66–pi); (1) present (Fig. 58–pi). The piriform spinning field is restricted to a narrow ribbon posteriorly (e.g. *Cyrtophora*; Coddington, 1989, figs 15, 19; *Mecynogea lemniscata*, Fig. 58–pi).

Character 71. Posterior median spinneret paracribellum: (0) strobilate; (1) deinopoid; (2) absent. The posterior median spinnerets of cribellate spiders occasionally have cribellar-like spigots. If so, they have the usual form of most entelegyne cribellates (e.g. *Dictyna arundinacea*, Fig. 51–pa) or they are long, with slight, cup-shaped annulations (e.g. *Deinopsis*, Coddington 1989: fig. 4; *Uloborus trilineatus*, Fig. 63–pa).

Character 72. Posterior median spinneret ampullate nubbins: (0) absent; (1) present. The posterior median spinnerets of nearly all spiders are equipped with one or more spigots (the minor ampullates, Fig. 48–pms, mi-ap) that resemble the ampullate gland spigots of the anterior lateral spinneret (Fig. 48–als, ma-ap). The manner in

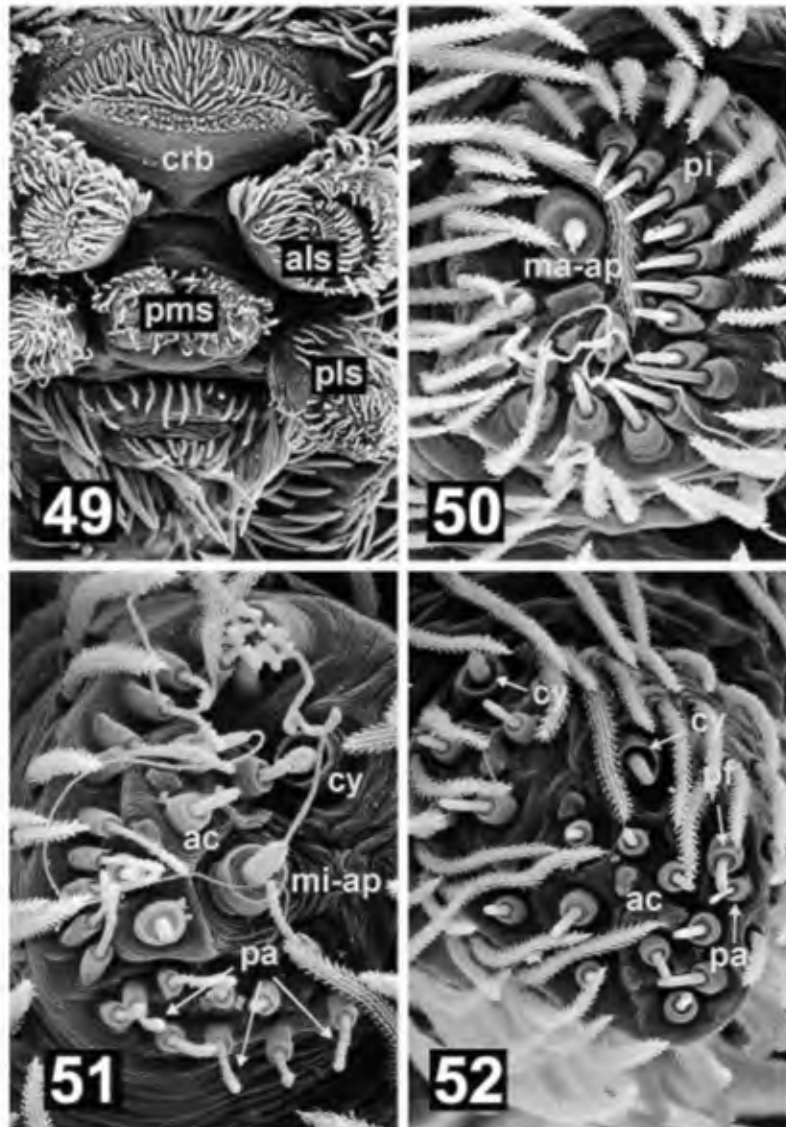

Figures 49–52. *Dictyna arundinacea*, spinnerets of female. Fig 49. Left and right spinneret group. Fig. 50. Anterior lateral spinneret, close-up. Fig. 51. Posterior median spinneret, close-up. Fig. 52. Posterior lateral spinneret, close-up. Abbreviations: ac = aciniform gland spigot(s), als = anterior lateral spinneret, crb = cribellum, cy = cylindrical gland spigots, ma-ap = major ampullate gland spigot, mi-ap = minor ampullate gland spigot, pa = paracribellar gland spigots, pf = pseudoflagelliform gland spigot, pi = piriform gland spigot, pls = posterior lateral spinneret, pms = posterior median spinneret.

which these spigots are replaced ontogenetically in successive instars is complex (Yu & Coddington, 1990). In basal araneoids, scars, or ‘nubbins’ of the subadult median minor ampullates are present in the adult stage (e.g. *Mecynogea lemniscata*, Fig. 59–nu; *Gasteracantha cancriformis*, Fig. 67–nu). The derived condition within araneoids is to lack any sign of minor ampullate nubbins in the adult female (e.g. *Theridula*, *Frontinella*,

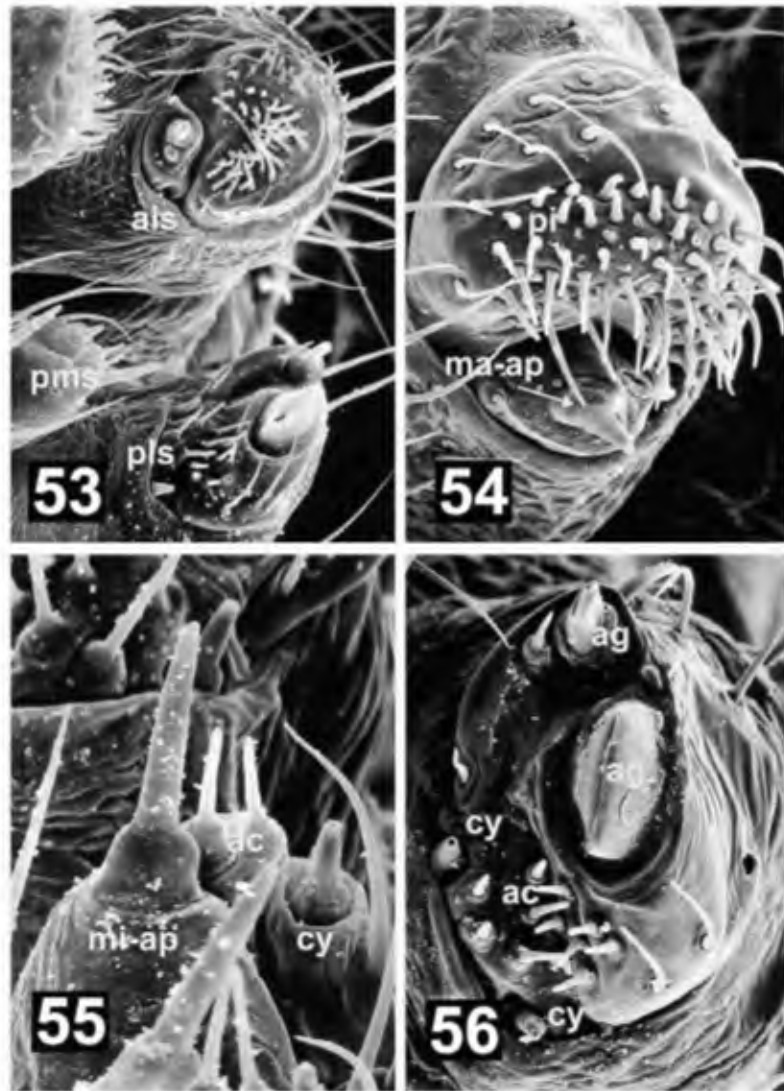

Figures 53–56. *Enoplognatha ovata*, spinnerets of female. Fig. 53. Left spinneret group. Fig. 54. Anterior lateral spinneret, close-up. Fig. 55. Posterior median spinneret, close-up. Fig. 56. Posterior lateral spinneret, close-up. Abbreviations: ac = aciniform gland spigot(s), ag = aggregate gland spigots, als = anterior lateral spinneret, cy = cylindrical gland spigots, ma-ap = major ampullate gland spigot, mi-ap = minor ampullate gland spigot, pi = piriform gland spigot, pls = posterior lateral spinneret, pms = posterior median spinneret.

Coddington, 1989, figs 31, 39; *Enoplognatha ovata*, Fig. 55). The theridiid codings are used for *Theridion*.

Character 73. Posterior median spinnerets with aciniform brush: (0) present (Figs 59, 63, 67, 71, 75); (1) absent/reduced (Figs 55, 79). Some araneoids have multiple aciniform gland spigots on the anterior face of the posterior median spinnerets (Fig. 48—pms, ac; e.g. *Metepeira foxi*, Fig. 75—ac). Few to no such spigots occur on the medians of theridiids, tetragnathids, theridiosomatids and linyphiids (e.g. *Frontinella*,

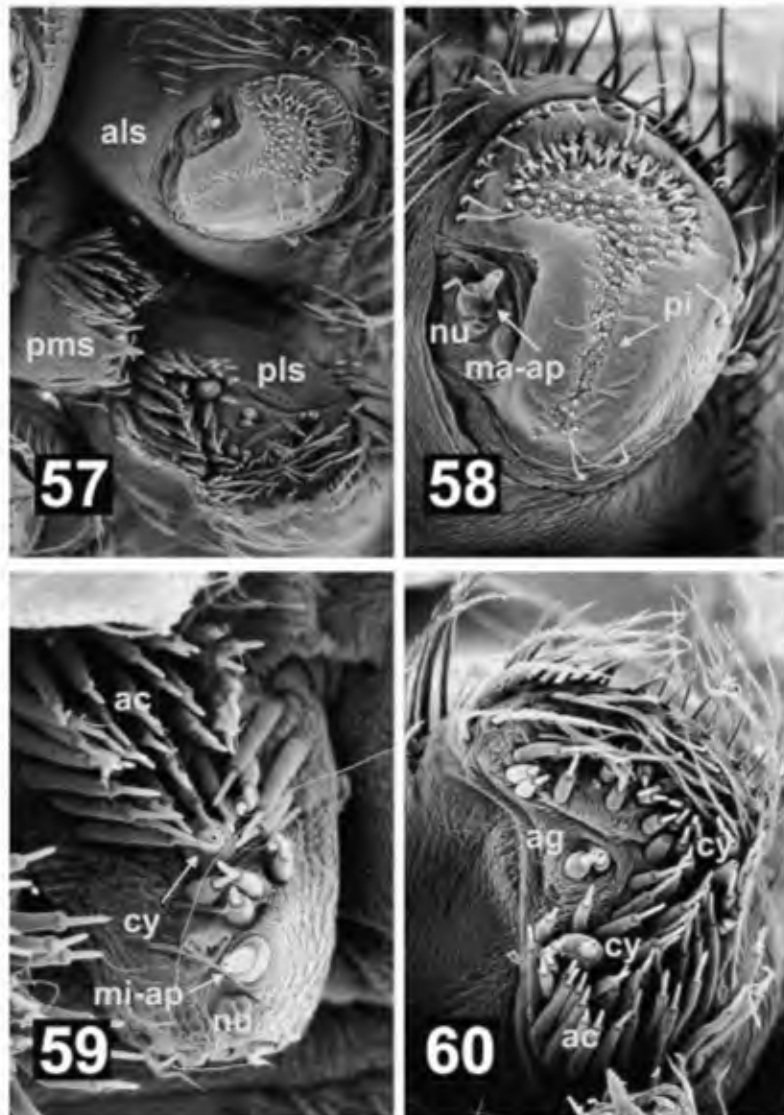

Figures 57–60. *Mecynogea lemniscata*, spinnerets of female. Fig. 57. Left spinneret group. Fig. 58. Anterior lateral spinneret, close-up. Fig. 59. Posterior median spinneret, close-up. Fig. 60. Posterior lateral spinneret, close-up. Abbreviations: ac = aciniform gland spigot(s), ag = aggregate gland spigots, als = anterior lateral spinneret, cy = cylindrical gland spigots, ma-ap = major ampullate gland spigot, mi-ap = minor ampullate gland spigot, nu = nubbin; pi = piriform gland spigot, pls = posterior lateral spinneret, pms = posterior median spinneret.

Coddington, 1989, fig. 40; *Enoplognatha ovata*, Fig. 55–ac). The theridiid codings are used for *Theridion*.

Behaviour

Character 74. Orb: (0) absent; (1) present; (2) lost. Within Orbiculariae, the web architecture known as the ‘orb’ (i.e. frames, radii, sticky spiral, etc. although

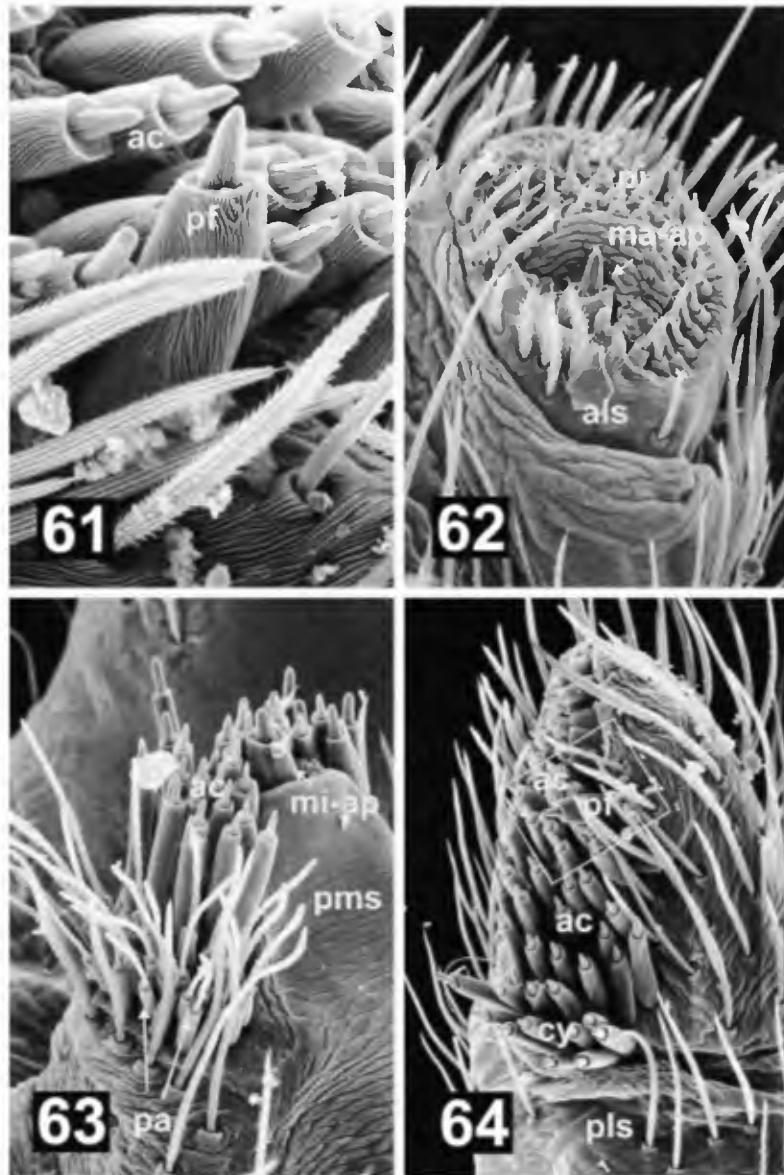

Figures 61–64. *Uloborus trilineatus*, spinnerets of female. Fig. 61. Pseudoflagelliform gland spigot and aciniform gland spigots on posterior lateral spinneret, close-up of white rectangle in Fig. 64. Fig. 62. Anterior lateral spinneret, close-up. Fig. 63. Posterior median spinneret, close-up. Fig. 64. Posterior lateral spinneret, close-up. Abbreviations: ac = aciniform gland spigot(s), als = anterior lateral spinneret, cy = cylindrical gland spigots, ma-ap = major ampullate gland spigot, mi-ap = minor ampullate gland spigot, pa = paracribellar gland spigots, pf = pseudoflagelliform gland spigot, pi = piriform gland spigot, pls = posterior lateral spinneret, pms = posterior median spinneret.

sometimes much modified) is primitive (Coddington & Levi, 1991). Outgroups to Orbiculariae (e.g. *Dictyna*), never spun orbs and, within Araneoidea, most families have lost or modified the orb architecture beyond recognition (e.g. *Achaeranea* Griswold *et al.* in press).

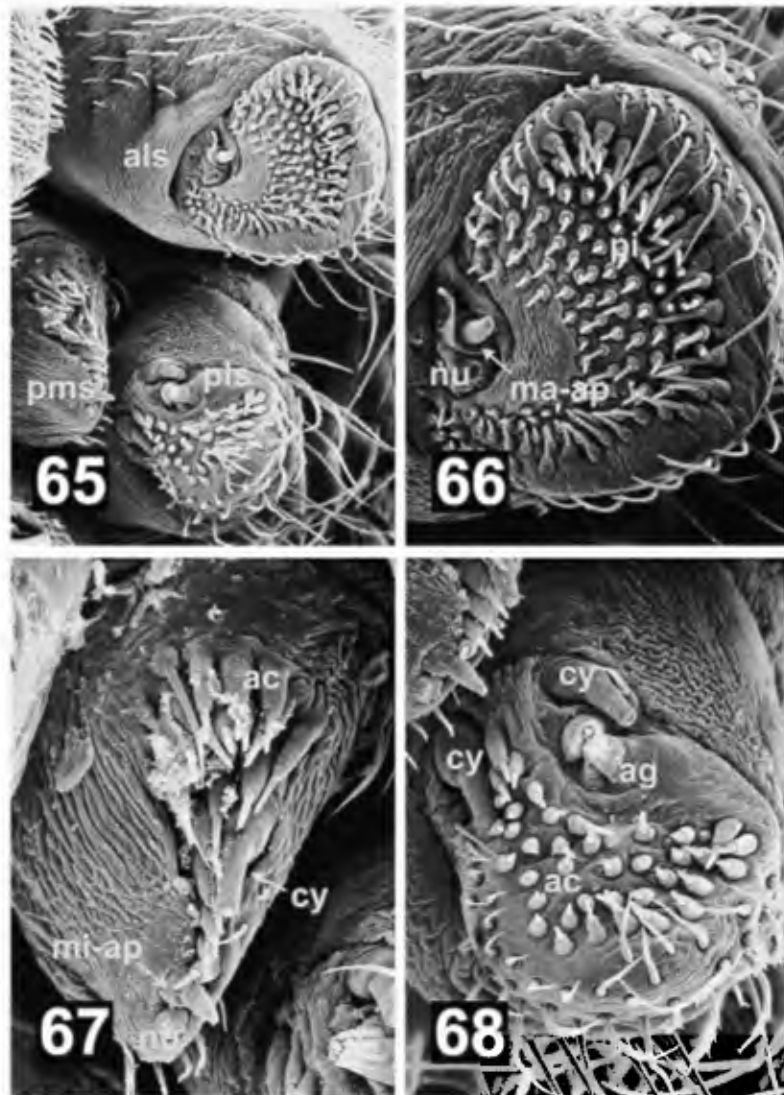

Figures 65–68. *Gasteracantha cancriformis*, spinnerets of female. Fig. 65. Left spinneret group. Fig. 66. Anterior lateral spinneret, close-up. Fig. 67. Posterior median spinneret, close-up. Fig. 68. Posterior lateral spinneret, close-up. Abbreviations: ac = aciniform gland spigot(s), ag = aggregate gland spigots, als = anterior lateral spinneret, cy = cylindrical gland spigots, ma-ap = major ampullate gland spigot, mi-ap = minor ampullate gland spigot, nu = nubbin, pi = piriform gland spigots, pls = posterior lateral spinneret, pms = posterior median spinneret.

Character 75. Orb-web: (0) with sticky spiral; (1) without sticky spiral (e.g. *Cytophora*).

Character 76. Method of radius construction: (0) araneid-like; (1) uloborid-like; (2) cyrtophorine-like; (3) nephiline-like. During radius construction, araneids cut and reel up the exit line as they return to the hub so that finished radial lines are single. Uloborids leave the exit line in place, so their radial lines are doubled. Cyrtophorines are similar to uloborids, but exit and return lines are distinct in the web. Nephilines

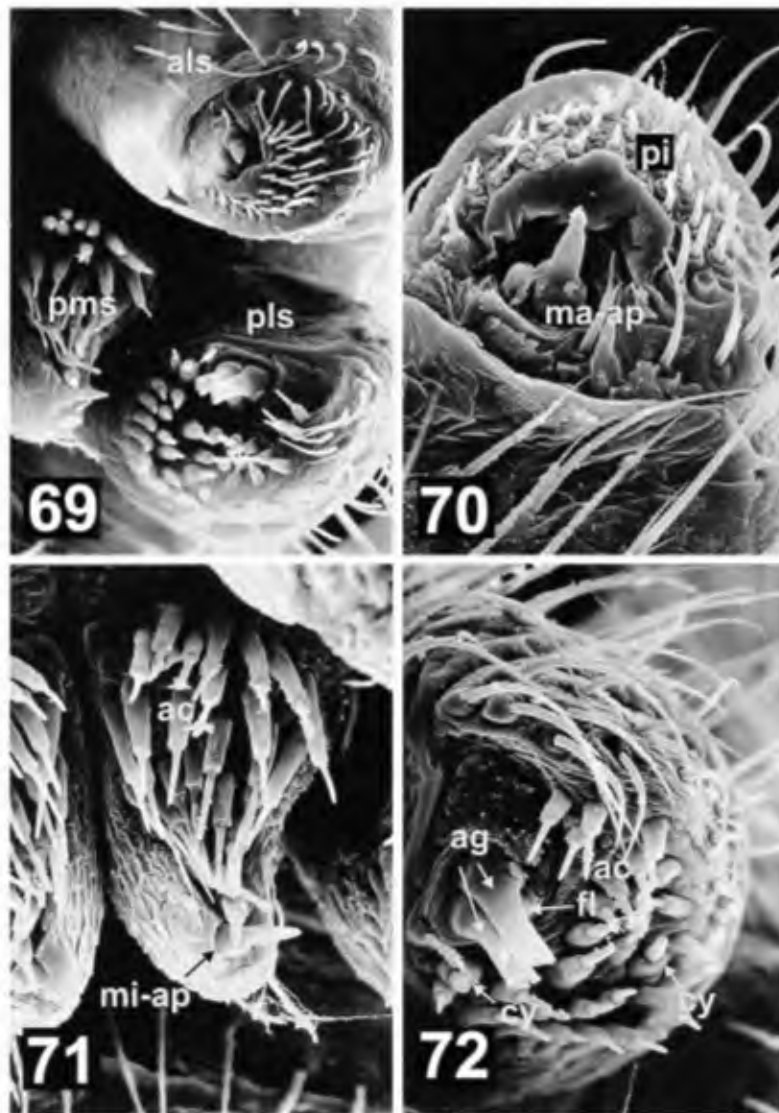

Figures 69–72. *Cyclosa* sp., spinnerets of female. Fig. 69. Left spinneret group. Fig. 70. Anterior lateral spinneret, close-up. Fig. 71. Posterior median spinneret, close-up. Fig. 72. Posterior lateral spinneret, close-up. Abbreviations: ac = aciniform gland spigot, ag = aggregate gland spigots, als = anterior lateral spinneret, cy = cylindrical gland spigots, fl = flagelliform gland spigot, ma-ap = major ampullate gland spigot, mi-ap = minor ampullate gland spigot, pi = piriform gland spigots, pls = posterior lateral spinneret, pms = posterior median spinneret.

also construct doubled radii, but attach at two points on the frame. See Eberhard (1982) for complete descriptions.

Character 77. Non-sticky spiral in web: (0) temporary; (1) persistent. In some spiders, the non-sticky spiral is not removed when the spider lays down the sticky spiral (e.g. *Nephilengys*, *Nephila*, *Cyrtophora*, *Mecynogea*).

Character 78. SS localization: (0) oL1; (1) iL1; (2) L4. During sticky spiral construction, the spider taps sideways with the outside first leg (= 'oL1') to locate the

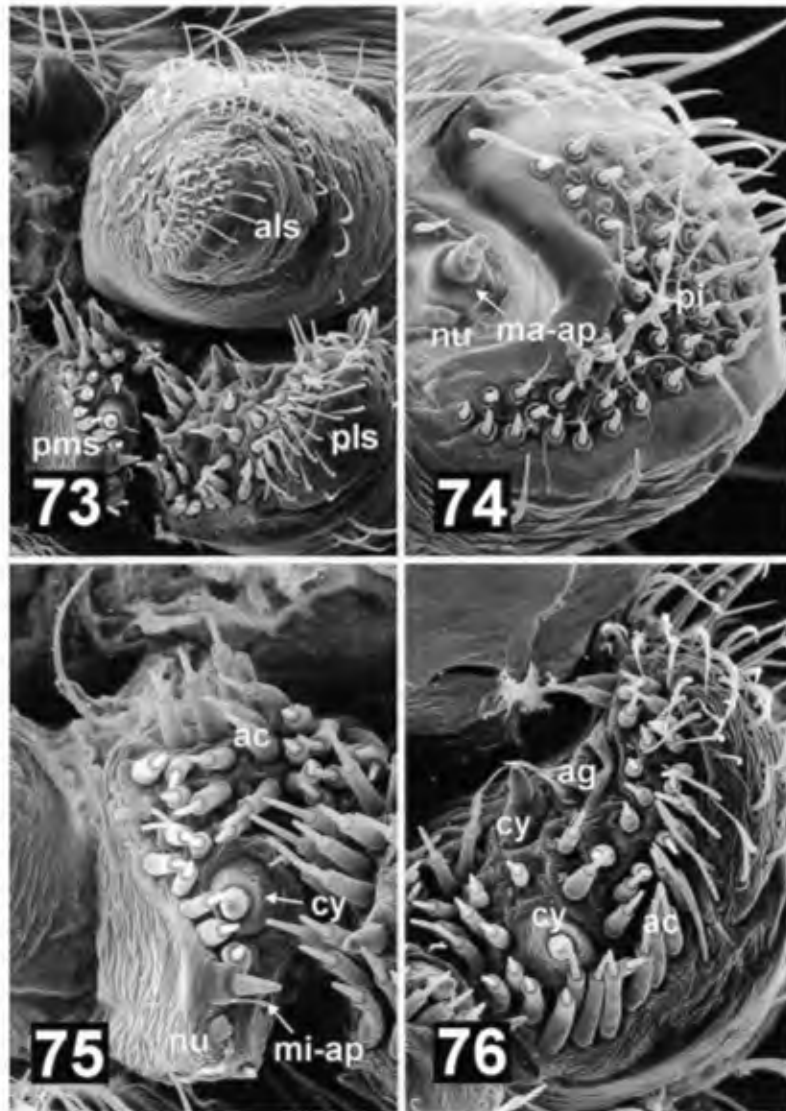

Figures 73–76. *Metepeira foxi*, spinnerets of female. Fig. 73. Left spinneret group. Fig. 74. Anterior lateral spinneret, close-up. Fig. 75. Posterior median spinneret, close-up. Fig. 76. Posterior lateral spinneret, close-up. Abbreviations: ac=aciniform gland spigot(s), ag=aggregate gland spigot, als=anterior lateral spinneret, cy=cylindrical gland spigots, ma-ap=major ampullate gland spigot, mi-ap=minor ampullate gland spigot, nu=nubbin, pi=piriform gland spigots, pls=posterior lateral spinneret, pms=posterior median spinneret.

outer sticky spiral segment (=‘SS’) in order to determine the spacing for the segment about to be attached to the radius. ‘Outside’ are the legs away from the hub, given the direction of the spiral. Derived araneoids tap forward with the inside first leg (=‘iL1’); ‘inside’ are the legs towards the hub. The large nephelines extend the fourth leg (=‘L4’) downwards, and move directly from one SS attachment to the

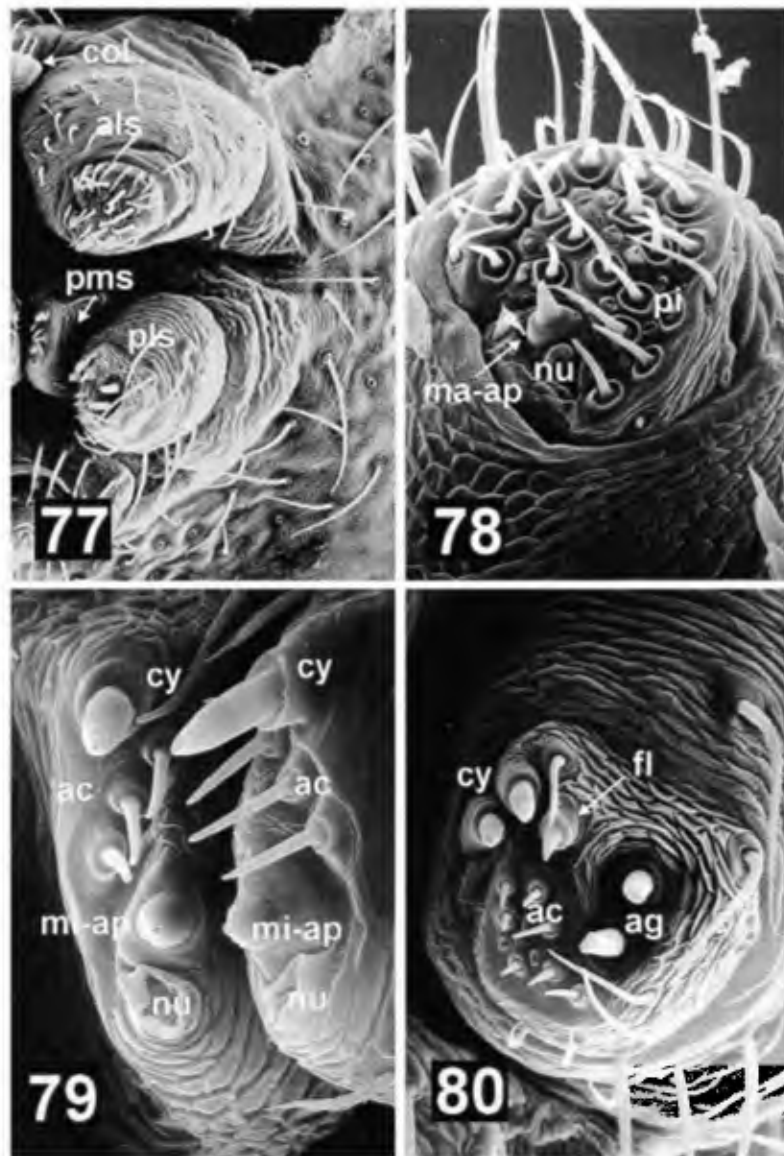

Figures 77–80. *Theridiosoma gemmosum*, spinnerets of female. Fig. 77. Left spinneret group. Fig. 78. Anterior lateral spinneret, close-up. Fig. 79. Right and left posterior median spinneret, close-up. Fig. 80. Posterior lateral spinneret, close-up. Abbreviations: ac = aciniform gland spigot(s), ag = aggregate gland spigots, als = anterior lateral spinneret, col = colulus, cy = cylindrical gland spigots, fl = flagelliform gland spigot, ma-ap = major ampullate gland spigot, mi-ap = minor ampullate gland spigot, nu = nubbin, pi = piriform gland spigots, pls = posterior lateral spinneret, pms = posterior median spinneret.

next (Eberhard, 1982: 1077, figs 2, 3 and 4). *Araneus* exemplifies the oL1 behaviour, *Leucauge* (Tetragnathidae) the iL1 behaviour and *Nephila* (Tetragnathidae) the L4 behaviour (Eberhard, 1982).

Character 79. Low-shear SS lines: (0) absent; (1) present. In some taxa the joint

between a sticky silk segment and the radius is especially weak and prone to break if contacted by prey (Stowe, 1986: 113) (e.g. *Pasilobus*).

Character 80. Very sticky SS lines: (0) absent; (1) present. Some sticky silks are so adhesive (or so abundantly supplied with glue) that a single SS line can hold large prey (Stowe, 1986: 118) (e.g. *Pasilobus*).

Character 81. Extreme L4 combining: (0) absent; (1) present. The spanning thread (also called the bridge thread) of the future web is spun with extensive combing action of leg IV (Stowe, 1986: 128) (e.g. *Pasilobus*).

Character 82. Ready posture at hub: (0) legs 1 and 2 flexed; (1) legs 1 and 2 extended. When in a 'ready for prey' posture at the hub, most orb web spiders sit with the front legs arched or flexed (e.g. *Neoscona*). Some orb-weavers, especially tetragnathids, sit with the front legs extended straight out in front (e.g. *Tetragnatha*).

RESULTS

Analysis

Most parsimonious trees

Over the course of the study we coded 71 versions of the matrix, running each several to many times in order to explore thoroughly the structure and behaviour of the data.

For the matrix of Table 3, using either the **t**; **bb***, **mh***; **bb**, or **h**; **bb*** search options the Hennig86 tree buffer overflowed at roughly 1364 trees of length 283 ($ci=0.35$; $ri=0.74$). Probably if we had varied taxon input order sufficiently, Hennig86 would have found the shorter trees, but we did not pursue that problem for this version of the data. Certainly the tree-finding abilities of Hennig86 alone were severely taxed and frequently defeated by this matrix. Using the closest addition strategy, TBR branch swapping, and a very large tree buffer, PAUP found 16 trees of length 282 ($ci=0.35$; $ri=0.74$). The '**bb***' branch swapper of Hennig86 applied to the PAUP solution set found no additional trees, but no combinations of search routines in Hennig86 found these trees by themselves. Using **empezar** and **max***, NONA found 12 trees of length 282 under both the '**amb-**' and '**amb=**' options, all of which were identical to the trees found by PAUP and Hennig86. The disparity in number results from a more strict definition of 'support' in the former as compared to the latter two programs (Goloboff, 1993a; Coddington & Scharff, 1995). When the 16 tree solution set was filtered for compatible but polytomous topologies (using the "Do not retain a polytomous tree for which a more highly resolved compatible tree exists" option in PAUP), eight trees resulted (all of which still retained one trichotomy involving *Mangora*). These eight trees represented all possible combinations of two placements each for *Meta*, *Larima*, and *Dolophones*.

To find all 'islands' of most parsimonious trees for this data set (Maddison, 1991), we used the '**mult**' procedure in NONA to perform several runs of randomized addition sequence searches (again under the '**amb-**' option). With 'hold' at 200, 46 of 400 searches found only the known 12 (or 16) tree island; '**amb=**; **max***' again found no additional trees. In PAUP 26 of 400 randomized addition sequence searches recovered only the previously known 16 (or 12) tree island. These results suggest that the single island found by NONA and PAUP, and corroborated by Hennig, represents all most parsimonious trees for these data.

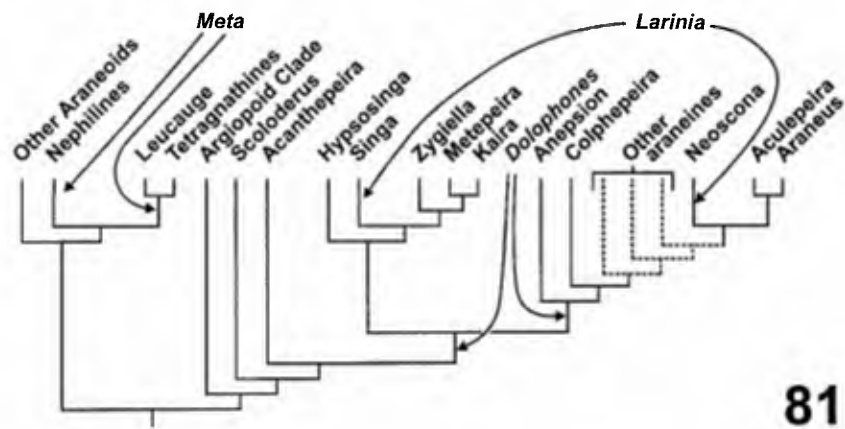

Figure 81. Summary topology of the eight most resolved most parsimonious cladograms showing alternative placements of *Meta*, *Larinia*, and *Dolophones*. Tree length 282, equally weighted data from Table 3.

Earlier in the analysis and before the matrix was completely scored for all taxa, the argiopine and cyrtarachine clades occasionally jumped from the gasteracanthoid to the araneine side of the tree, depending on taxon and character inclusion/exclusion and variations in character coding. Subsequent additions of taxa (e.g. *Anepsion*, *Arachnura*, *Archemorus*, *Arkys*, *Chorizopes*, *Hypognatha*, and *Dolophones*) stabilized the position of these subfamilies with gasteracanthoids if data were equally weighed, but the evidence favouring either placement is sparse, debatable, and almost evenly balanced.

This matrix was and remains sensitive to inclusion or exclusion of characters and taxa. Obtaining robust results on 70 taxa from 89 informative comparisons will always be rather unlikely for most normal data sets (Sanderson & Donoghue, 1989), so the instability of these data is not surprising. The matrix contains too many taxa and too few characters, but *post-hoc* selection of taxa to delete from the ingroup is difficult to justify. Throughout the course of the analysis, experimental deletion of taxa and characters sometimes resulted in as few as three trees, but more often resulted in as many or more trees.

Tree choice

The final stage of analysis were directed toward identifying one or a few topologies from the set of most parsimonious trees on which to optimize characters and examine their evolution.

As noted above, the 16 most parsimonious trees differed in three respects. *Meta* and *Larinia* each had two, and *Dolophones* four possible placements, which in all possible combinations generated the 16 trees found by PAUP/Hennig86 ($2 \times 2 \times 4$). Two of the *Dolophones* placements were merely less resolved versions of the other two completely resolved solutions. Eliminating all the compatible but polytomous topologies for the reasons explained in Methods and in Coddington & Scharff (1996) left eight truly different trees.

Figure 81 depicts the differences between these eight most resolved most parsimonious trees. Rather than publishing the strict consensus, which, due to the

jumping behaviour of *Larinia*, would bluntly collapse many araneine nodes distal to *Acanthepeira* into a 14-tomy, we simply indicate the alternative placements for *Dolophones*, *Meta*, and *Larinia*.

To narrow the choice of phylogenetic hypotheses further, we used successive weighting in PAUP (base weight 1000 on the maximum rescaled consistency index with values rounded rather than truncated) to obtain four trees stable to the re-weighting procedure. At each cycle of character re-weighting, we filtered the solution set to exclude compatible polytomous trees, for the reasons explained in Methods. With weights returned to unity, all four trees were 285 steps, three steps longer than the minimal length equally weighted solutions. When filtered to remove compatible polytomous topologies, only two trees remained, which differed between themselves only in the placements of *Dolophones*.

The successively weighted topologies differed from the equally weighted results in seven respects. First, all successively weighted topologies placed *Meta* with *Nephila*–*Nephilengys*. The equally weighted results allowed that placement but equally well put *Meta* as sister to the *Leucauge*–*Tetragnatha* clade. Using a larger selection of taxa and characters (including behavioral characters unavailable for most araneids), Hormiga *et al.* (1995) also found the *Leucauge*–*Tetragnatha* placement. Because their analysis directly targeted tetragnathid phylogeny, we accept the latter placement. This eliminated the four topologies that placed *Meta* with *Nephila*–*Nephilengys*, and left four equally weighted trees.

Second, the equally weighted results specified two placements for *Larinia*, one as sister to *Singa*, and one as sister to *Araneus*–*Aculepeira*. The successively weighted results agreed with the latter. The character evidence for either choice is not decisive (see below), and so we eliminated both *Larinia*–*Singa* topologies from the remaining four equalled weighted trees, leaving two trees.

Third, both the equally and the successively weighted results offered two placements for *Dolophones*, one as sister to the *Hypsosinga* clade plus remaining araneines, and one as sister to *Anepision* plus remaining araneines. The former resolution requires two gains and a loss of the paramedian apophysis (*18*), whereas the latter allows one gain and two losses. We prefer the second explanation because it preserves homology of the paramedian apophysis (in this region of the tree) and allocates homoplasy to secondary loss.

In sum, comparison of the equally and successively weighted trees, consideration of other research results, and preference for preserving homology of complex characters thus leads us to prefer just one of the eight most resolved most parsimonious equally weighted trees (Fig. 82) as the working hypothesis for araneid phylogeny. We have optimized all characters on that tree (Figs 83–87). We used successive weighting to pick among resolutions of subclades, rather than whole topologies, a logical extension of the use advocated by Carpenter (1988) when areas of disagreement are independent of each other. These two hypotheses (the successively weighted versus the equally weighted) agree in nearly all respects, in fact, on 62 of the 66 possible nodes for a 70-taxon problem that contains two trichotomies (at the root and involving *Mangora*). The four contested nodes are contrasted in Figure 88, and require a net cost of three extra steps in the weighted solution.

In the weighted tree, the ‘argiopine clade’ and Cyrtarachninae jump from the ‘setal base clade’ to the araneine side of the tree, and the genus *Chorizopes* also shifts into the gasteracanthoids. Within gasteracanthoids, the *Hypognatha* clade and *Encyosaccus* shift slightly on the weighted tree. Throughout this analysis, the placement

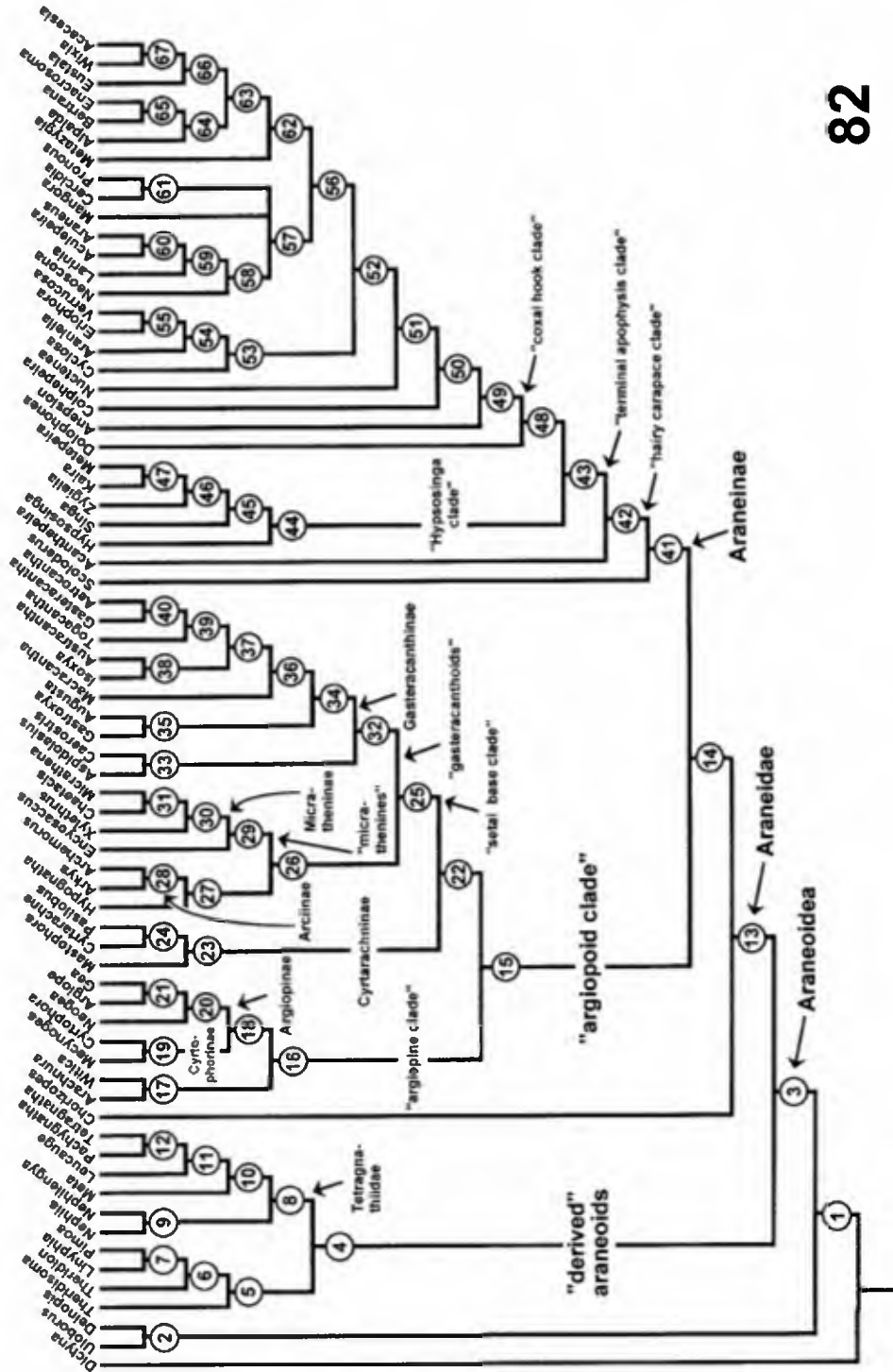

Figure 82. Preferred, most resolved, most parsimonious, equally weighted tree for the data of Table 3. Tree length is 282 (ci=0.35; ri=0.74). Node numbers are carried over to Figs 83-87. For more information on character support for each node, see Appendix.

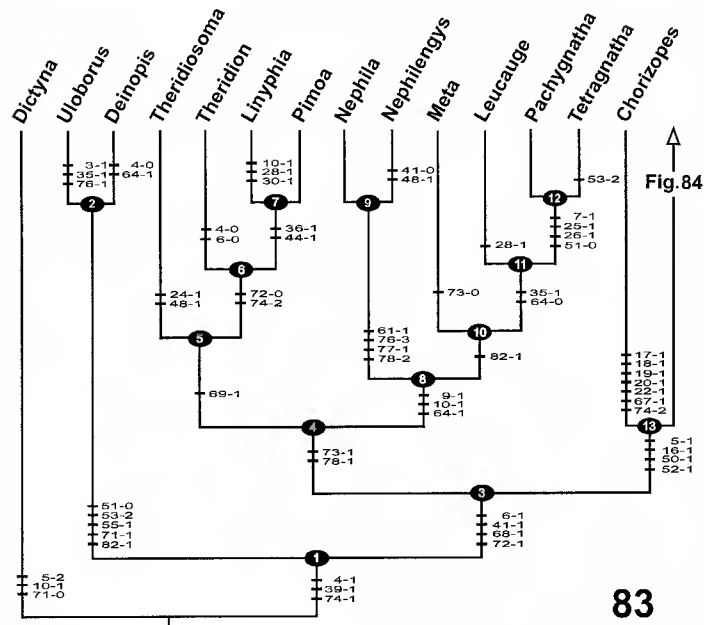

Figure 83. Clade 1 with characters optimized on subtree including 'derived araneoids'.

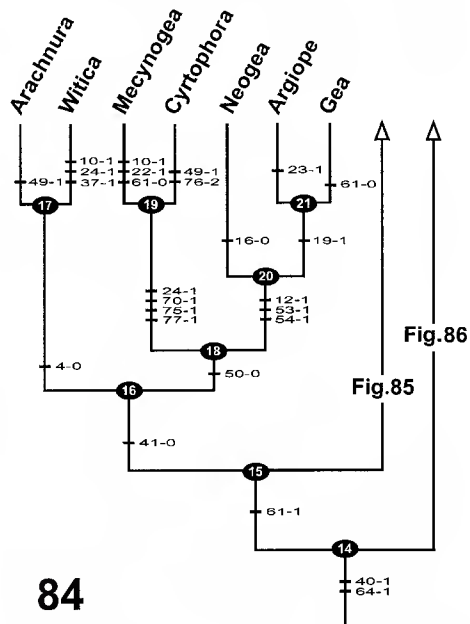

Figure 84. Clade 14 with characters optimized on subtree including 'argiopine clade'.

of Cyrtarachninae and/or the 'argiopine clade' with araneines appeared occasionally as alternative or near-parsimonious solutions, and so one must conclude that this arrangement of major clades of Araneidae is a strong possibility. In fact it costs only

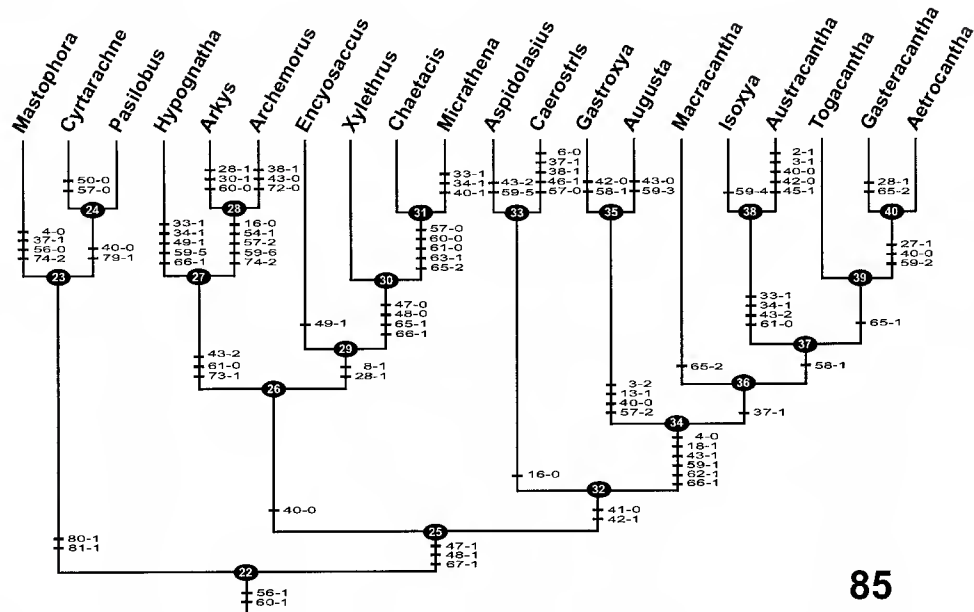

Figure 85. Clade 22 with characters optimized on subtree including Cyrtarachniae and 'setal base clade'.

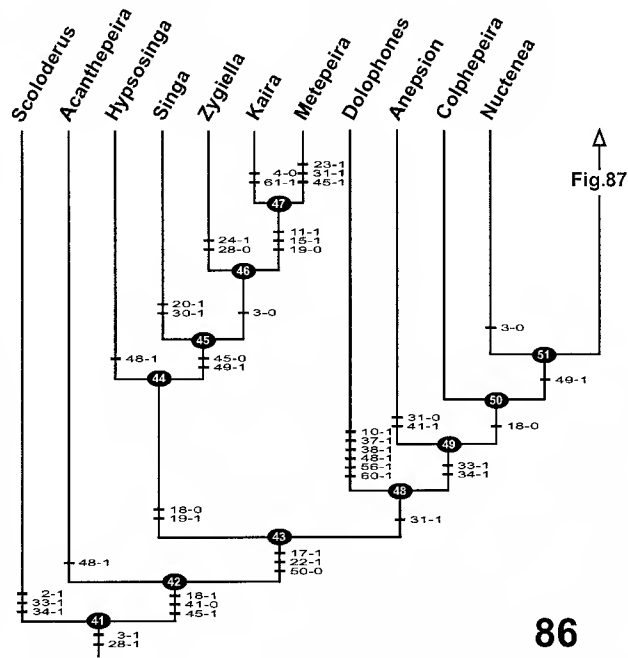

Figure 86. Clade 41 with characters optimized on subtree including 'Hyposinga clade'.

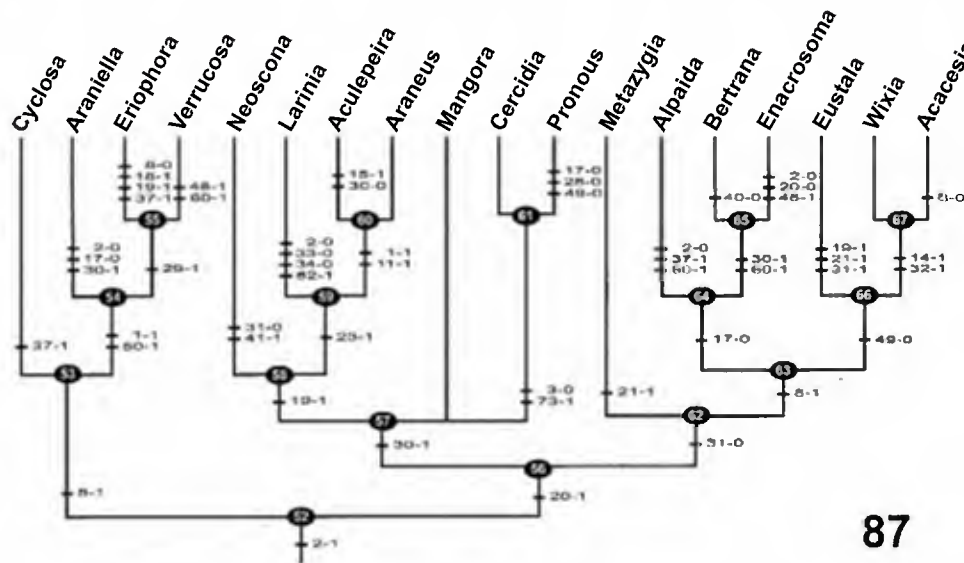

Figure 87. Clade 52 with characters optimized on subtree including 'higher araneines'.

one net step on the equally weighted tree, although several characters change length as a consequence.

Altogether, seven characters fit the weighted tree worse than the unweighted tree: the lobed conductor (8), the female scape (28), the sustentaculum (40), the hirsute versus glabrous carapace (41), the female abdomen shape (42), sexual size dimorphism (61), and the resting posture on the web (82). Four characters fit it better: the male carapace shape (43), the enlarged female cephalon (47), the high cephalic height (48), male abdomen shape (59), and the modified gasteracanthine setal bases (67). In general, it is not possible to specify which change in the tree causes (or is caused by) which change in length because they interact. Overall, however, the characters that fit the weighted tree better concern gasteracanthoid relationships, and the ones that fit it worse are not particular to any subgroup of araneids.

In sum, with respect to the weighted topology, the successive weighting procedure corroborated 62 of the 66 nodes in Figure 82 that were free to vary in the analysis. It suggested a few differences, but at fairly high cost. The characters responsible for the differences, and that received higher weight, are not obviously 'better' characters, although they do tend to concern gasteracanthines and their relatives. Insofar as the gasteracanthoid arrangement in Figure 88 is perhaps a 'better' explanation of features most prevalent in that clade, it should be investigated further in future work on gasteracanthine phylogeny.

Character evidence for major clades

Detailed diagnosis and justification of all nodes for Figure 82 are presented in the Appendix, but here we tabulate the evidence for major clades (subfamilies) of Araneidae. In Table 3 we also list for each character on Figures 83–87 the number of steps, the consistency index, the retention index, and the *post hoc* weights (see

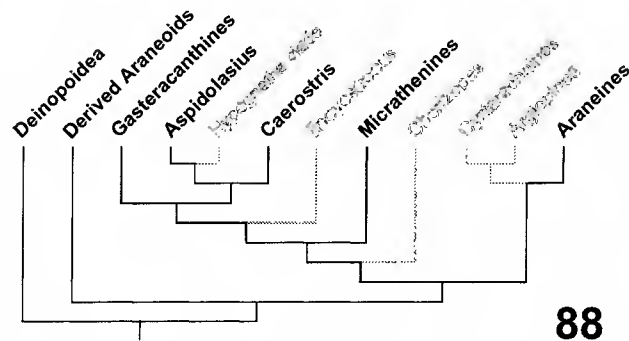

Figure 88. Summary topology of the four successively weighted trees, showing the four areas (marked in gray) where they differ from the equally weighted trees. Tree length is 285.

Methods) assigned to it by the successive weighting procedure. The latter statistic is an additional measure of concordance and fit in the data.

Four characters support the monophyly of Araneidae (clade 13): the mesal position of the cymbium (5), the radix (16), the wide separation of lateral eye groups from the medians (50), and the narrow posterior median eyes tapetum (52). The monophyly of Araneidae apart from *Chorizopes* (clade 14) is supported by the presence of a sustentaculum (40), and by the grooved booklung cover (64).

Araneinae (clade 41) is supported by two characters: male femora with tubercles (3) and the presence of a scape (28).

Three characters support the monophyly of Argiopeinae (clade 20): the presence of a threadlike spur on the median apophysis of the male palp (12), the reduced canoe-shaped tapetum of the posterior lateral eyes (53), and the procurved posterior eye row (54).

Four characters support the monophyly of Cyrtophorinae (clade 19): embolus anticlockwise direction (24), piriform fields of anterior spinnerets reduced (70), web without sticky silk (75), and non-sticky spiral left untouched (77).

The subfamily Cyrtarachninae (clade 23) is supported by two behavioral characters: the very sticky SS lines (80) and the extreme L4 combing (81).

The subfamily Arciinae (clade 28), formerly placed in Mimetidae, is supported by five characters: the loss of the radix (16), the procurved posterior eye row (54), the double row of abdominal sigillae (57), the unique triangular abdominal shape (59), and the lost orb-web (74). Three characters support the monophyly of *Hypognatha* and Arciinae (clade 27): Male carapace shape wide (43), male and females of equal size (size dimorphism lost) (61), and reduced aciniform gland spigot brush on posterior median spinnerets (73).

Six characters support the classic, mainly Old World Gasteracanthinae (clade 34): macro-setae on male palpal patella lost (4), paramedian apophysis present (18), male carapace of characteristic 'gasteracanthine' shape (43), male abdomen star-shaped (59), female abdomen with three pairs of spines (62), and spiracle sclerotized (66).

The classic new world subfamily Microtheleninae (clade 29) is supported by four characters: female cephalon reversed to normal shape (as opposed to high and broad) (47, 48), sclerotized ring around spinnerets (65), and a sclerotized spiracle (66).

In summary, with respect to character support, seven classically recognized 'core' lineages of araneids are corroborated by both weighted and equally weighted data: Cyrtophorinae, Argiopinae, Cyrtarachninae, Arciinae, Gasteracanthinae, Micratheninae, and Araneinae. Results at the tribal level are discussed below.

DISCUSSION

Methodology

At times during this study, earlier versions of this data matrix yielded in excess of 60 000 most parsimonious trees. The improvement in resolution and decisiveness in this version seems mainly to have been due to inclusion of about a dozen more araneid genera (mainly paleotropical), and the new characters they offered, as well as the decision to discard a few characters of ambiguous definition that seemed to fit no tree well (see below).

However, we also had to develop some novel (at least to us) analytical techniques and theoretical perspectives to process this large and unwieldy data set. Perhaps the most important was the realization that polytomous cladograms are often more trouble to consider than they are worth in this sort of analysis (Coddington & Scharff, 1996). Of even more fundamental importance was the realization that when commonly available software is used to analyse matrices like this one (i.e. many taxa, few characters, many poorly or ambiguously supported nodes), a substantial fraction of the trees in the solution set will contain zero-length branches, and therefore should be discarded (Coddington & Scharff, 1995).

Successive weighting is another way to choose among equally parsimonious trees. All too often, however, the successively weighted result is a few steps longer than the equally weighted solution set. In these cases, the character support for all topological differences must be carefully checked to see if it is sensible. In our experience, successive weighting can easily down-weight complex, objectively definable homologies that have been meticulously examined to favour data with many missing entries or that are simply not so clearly defined. That successive weighting should behave in this way is not particularly surprising. Algorithms lack judgment. The successively weighted results for this matrix were at best three steps longer on the original data. We were therefore less inclined to take its advice than if it had produced minimal trees.

We also found it useful to avoid the use of strict consensus trees. The solution set of 16 most parsimonious trees presents nearly a 'bush' among araneines if a strict consensus tree is computed. If we had simply accepted such results at face value, much phylogenetic structure that was common to all trees would have been missed.

The probability of independent ambiguous regions in data sets must increase with the size of the data set. If so, running larger and larger data sets will lead inexorably to incomprehensibly large numbers of trees, even though the logical phylogenetic problems generating them may be relatively simple and few in number. On the other hand, poor taxon sampling is probably the single biggest sources of variation in cladistic results; it provides a powerful motive to include as many taxa as possible. The analysis of large data sets created to estimate the phylogeny of still larger groups thus raises numerous methodological issues. The older literature of phylogenetic

systematics did not anticipate this problem. Maddison *et al.* (1984) argued strongly for ‘global parsimony’, by which they meant that unless all taxa and all characters relevant to a question were considered within the same data set, most parsimonious solutions might escape the analysis. An important design consideration for new algorithms has been capacity and speed (Platnick, 1989b). Our experience with this data set suggests that this approach will ultimately fail. In the limit, independent regions of topological ambiguity interacting multiplicatively will defeat any search for all permutations of most parsimonious solutions for each region. In any case such a brute search is not very interesting. Except for the purpose of consensus procedures that use relative frequency of topological variants (such as majority-rule trees), one does not need to compute all permutations in order to obtain the most commonly used consensus solutions.

No currently available computer could perform an effective analysis on the 2600 araneid species already known to exist. ‘Global’ parsimony may remain a logical criterion but it is unlikely to be the basis of an effective search strategy. An obvious alternative is to perform complete analyses at lower taxonomic levels. Groundplan character state vectors could then be inferred at the basal nodes of component groups, and these inferred groundplan descriptions could serve as terminal taxa in a higher level analysis. This approach assumes (1) that the lower-level analysis yields one preferred tree: (2) that enough characters can be unambiguously optimized to the root to make the method worthwhile, and (3) that the juxtaposition of new outgroups to the groundplan vectors in the larger analysis will not require their revision.

Finally, we have made it clear that multiple most parsimonious, and many more nearly parsimonious hypotheses for these data exist. Nevertheless, we feel that it is better to recommend a detailed hypothesis, i.e. one preferred tree, than to be ‘conservative’ by simply publishing a consensus tree, or, worse, the majority rule consensus tree of bootstrapped, jackknifed, or otherwise permuted morphological data. One thousand trees is not a solution, and neither is an unresolved polytomy. While the phylogeny presented here may soon require revision, its very specificity should bring about such revision more quickly.

Phylogeny of Araneidae

Figures 81–87 summarize the results of this analysis. We first discuss the coarse phylogenetic structure of Araneidae, and then consider selected clades.

This analysis suggests for the first time two major lineages of araneids—essentially the classical subfamily Araneinae (including *Zygiella*) and its sister taxon, which appears to be all other araneid subfamilies (including *Arkys* and *Archemorus*), and which we call the ‘argiopoid clade’. We refrain from formally naming this lineage because this region of the cladogram is not particularly stable and considerable violence to traditional subfamily concepts and novel categories would be required in order to recognize a rank between family and subfamily.

The cladogram at the level of classical subfamilies is fairly stable. Simon (1892–5) divided his Argiopinae (roughly equivalent to modern-day Araneidae) into a number of small tribes, each holding less than 10 genera (Table 1). Some of the names of Simon’s tribes have been used to form modern subfamily names (e.g. Argiopeae–Argiopinae, Cyrtophoreae–Cyrtophorinae, Araneae–Araneinae, Gasteracanthaeae–

Gastercanthinae, Micratheneae–Micratheninae), but many of the names have been more or less dropped from modern usage. If we compare the result of this analysis with the groupings originally suggested by Simon, many of his groupings survive, but some are radically changed.

At the tribal level (Table 1) the monophyly of Cyrtarachneae is confirmed. Three tribes are seriously polyphyletic (Cycloseae, Micratheneae, Anepsieae), Araneae is paraphyletic, and Mangoreae could be monophyletic. The monophyly of seven monotypic tribes is moot, because monotypic taxa are trivial as groups (Arachnureae, Caerostreae, Xylethrae, Dolophoneae, Testudinariae, Urseae, and Hypognatheae). As more araneid genera are analysed cladistically, they may be placed in these monotypic tribes, at which point the names would serve a grouping function. Finally, although five other tribes (Bertraneae, Exechocentreae, Celaeneae, Chorizopeae, and Poltyeae) do contain more than one genus, we were not able to include enough taxa in this study to test them.

Where appropriate, we also comment on whether these higher araneid taxa as identified by morphological criteria are also distinctive or coherent biologically—that is, whether the members of the group spin the same sorts of webs, have distinctive apomorphies of behaviour or habit, etc.

Arciinae and Eurycorminae

Simon (1892–5) placed the genera *Arkys* and *Archemorus* (Old World genera) in the subfamily Arciinae and *Hypognatha* (New World genus) in the subfamily Eurycorminae (Table 1). Simon placed all three genera in Araneidae, but made a note (p. 898) saying that he had originally intended to place *Arkys* in Mimetidae, but later changed his mind. Simon (p. 898) suggested a close connection between *Arkys*, *Hypognatha*, and *Dolophones*. Subsequent authors have been divided over the placement of *Arkys* and *Archemorus* and silent as to the placement of *Hypognatha* and *Dolophones*. Thus Roewer (1942), Bonnet (1945–61), Chrysanthus (1971) and Brignoli (1983) placed *Arkys* and *Archemorus* in Araneidae. Heimer (1984) transferred both genera to the family Mimetidae, a placement supported by the complex paracymbium of the male palp, a supposed cooperation between the paracymbium and the median apophysis of the male palp, and the lack of a conductor (Heimer, 1984: 158). Davies (1988), in her guide to Australian orb-weaving spiders, suggested a ‘tentative’ placement in the subfamily Metinae of the family Tetragnathidae. In a recent review of the mimetid spiders of Chile, Platnick & Shadab (1993) reported the presence of aggregate gland spigots on the posterior spinnerets of *Arkys*, and thereby excluded them from Mimetidae. Most araneoids still retain aggregate and flagelliform spigots (Fig. 72). In this analysis, both weighted and equally weighted trees had *Arkys* + *Archemorus* firmly nested within the argiopoid clade and always as sister to *Hypognatha*. Simon’s initial ideas about a close relationship between *Arkys* + *Archemorus* and *Hypognatha* are thus confirmed in this study.

Biologically, however, Arciinae and Eurycorminae are very different. *Hypognatha* makes a widely spaced, delicate, vertical orb-web. It is unknown whether they are primarily day or night active. *Arkys* and *Archemorus* spin no web at all (or very little), and apparently are sit-and-wait predators, much in the style of crab spiders (Heimer, 1984; Main, 1982).

Tetragnathidae

The tetragnathids (Fig. 83) were analysed by Hormiga *et al.* (1995) who included a much larger set of taxa and characters relevant to tetragnathid phylogeny. Our

analysis supports the findings of Hormiga *et al.* (1995), but is ambiguous on the placement of *Meta* within Tetragnathidae. Like Hormiga *et al.* (1995), we have substantial evidence that *Meta* is not an araneid, contrary to what some authors have claimed. Forcing *Meta* to join Araneinae costs 7 extra steps (e.g. as sister to clade 41, Fig. 82).

Argiopinae

The monophyly of Simon's Argiopeae (*Argiope* and *Gea*) is supported by this analysis (Fig. 84). The argiopines were recently revised by Levi (1983), who added the genus *Neogea* to the group and demonstrated the monophyly of the three genera. However, Levi (1983) and Levi & Coddington (1983) considered Argiopinae to be sister to the rest of Araneidae. Using MacClade and its primitive branch-swapping routine to re-arrange taxa, this alternative would be four steps longer than the tree in Fig. 82. Levi (1983) used the presence of a radix in *Gea* and *Argiope* as a synapomorphy for the two genera, but outgroup comparison to the rest of the araneids shows that a radix is plesiomorphic and therefore cannot be used to indicate relationship. In contrast, the lack of a radix in *Neogea* is an autapomorphy for this genus. One other character (19) supports the monophyly of *Argiope* + *Gea*. The radix instead emerges as a synapomorphy for all of Araneidae, subsequently lost in *Neogea*, *Caerostris*, *Aspidolasius*, and in *Arciinae*. Both weighted and equally weighted trees agree on the sister-group relationship between Argiopinae and Cyrtophorinae, but the weighted analysis places the 'argiopine clade' together with cyrtarachnines as a sister-group to Araneinae (see section on tree choice). Since the cost of this move is only one step, this sister-group relationship is a possible alternative and should be considered further in future analyses of Araneidae.

It is also interesting to note that the biology of Argiopinae, as far as is known, seems coherent. Argiopeae tend to be diurnal, conspicuous (to humans, at least), sun-loving, brightly coloured, weavers of classic orbs that usually sit at the hub and have a strong tendency to decorate their webs with stabilimenta.

Cyrtophorinae

Simon (1892–5) established a separate tribe, Cyrtophoreae, for *Mecynogea* and *Cyrtophora*. Since then, most authors have placed the genera in separate subfamilies, though few agreed on which subfamilies. Comstock (1912a) placed *Mecynogea* (then *Hentzia*) in Metinae (Tetragnathidae). Petrunkevitch (1928) placed *Mecynogea* in Argiopinae and *Cyrtophora* in Araneinae. Levi (1980b) placed *Mecynogea* in Araneinae. Eberhard (1982) placed *Cyrtophora* in Simon's Mangoreae (see Table 1). Roewer (1942) placed *Mecynogea* in Argiopinae and *Cyrtophora* in Simon's Cyrtophoreae. Based on the derived location of piriform spigots (Fig. 58–pi) and other characters, Coddington (1989) suggested the monophyly of *Mecynogea* + *Cyrtophora* and this study also corroborates the monophyly of Simon's Cyrtophoreae.

The biology of Cyrtophorinae is extremely uniform. Their web architecture (a horizontal, very tightly woven mesh with an extremely tight, permanent non-sticky spiral) is diagnostic, and, like Argiopinae, they are diurnal, brightly coloured, and tend to stay at the hub, albeit protected by some sort of constructed and concealing retreat.

Cyrtarachninae

Simon (1892–5) established the tribes Glyptocranieae to hold the bolas spiders (*Dicrostichus*, *Agathostichus*, *Mastophora* (= *Glyptocranium*), *Cladomelea* and *Ordgarius*) and Cyrtarachneae to hold *Pasilobus*, *Paraplectana*, and *Cyrtarachne*. Mello-Leitão (1931) established the alternative name Mastophoreae for Glyptocranieae and this name was subsequently adopted by Roewer (1942) and Gertsch (1955). Eberhard (1980), Robinson (1982), Stowe (1986), and Yeargan (1994) agree that Cyrtarachneae and Mastophoreae are sister groups. We used the same evidence these authors marshalled to place these tribes in this cladogram. These data support the monophyly of Cyrtarachneae and the sister-group relationship to Mastophoreae. It seems worthwhile to recognize the relation formally at the subfamily level. Stowe (1986) also tentatively suggested that *Kaira*, which also uses aggressive chemical mimicry to attract prey, had evolved this specialization independently. Our results confirm this idea fairly strongly. *Kaira* seems to be an araneine spider. It cost six steps for force *Kaira* to join cyrtarachnines. In contrast, Simon (1892–5: 881) thought Mastophoreae to be ‘intermediate’ between Cyrtarachneae and Poltyeae (*Kaira*).

The biology of Cyrtarachninae is fairly coherent. There is a strong tendency towards web reduction, compensated, apparently, by the evolution of aggressive chemical mimicry (reviewed by Stowe, 1986; Yeargan, 1994).

Gasteracanthinae and Micratheninae

The monophyly of spiny orb-weavers (Fig. 85) is one of the most controversial topics in araneid phylogeny. Simon (1892–5) divided the spiny orb-weavers into two separate groups, and authors have been divided on this topic ever since. Simon’s Gasteracanthae included *Gasteracantha*, *Encyosaccus*, *Macracantha* and *Isoxya* (largely Old World), which according to our results is polyphyletic (by including *Encyosaccus*). Micratheneae included *Micrathena*, *Chaetacis* and *Pronous* (largely New World), which would also be polyphyletic according to our results (by including *Pronous*). Dahl (1914) followed Simon in separating the New and Old World spiny orb-weavers into two groups, but he was silent on the relationships between these groups or to other araneids. Roewer (1942) divided the spiny orb-weavers into four groups (Gasteracanthae, Xylethrae, Tecmessae and Micratheneae) and placed *Encyosaccus* in Gasteracanthae. His Micratheneae included *Chaetacis*, *Micrathena*, *Enacrosoma*, *Ildibaha* (= *Micrathena*), *Pronous* and *Pronoides*. Emerit (1972) followed Roewer, placing *Encyosaccus* in Gasteracanthinae and *Micrathena*, *Chaetacis* and *Ildibaha* in Micratheninae. None of the authors presented any characters to support their suggested groupings.

In our analysis, the ‘gasteracanthines’ were remarkably stable as a group, and none of the proposed groupings suggested by earlier authors are monophyletic. They are all paraphyletic in lacking *Caerostris* and *Aspidolasius*, and several are polyphyletic by incorporating taxa from distant lineages (e.g. *Enacrosoma*, *Pronous*, *Chthonos* (= *Tecmessa*) and *Pronoides*). *Chthonos*, for example, is a theridiosomatid (Coddington, 1986b).

Based on Figure 82, one can recognize two stable, monophyletic groups of spiny orb-weavers (clades 30 and 34), equivalent to micrathenines and gasteracanthines. Both weighted and equally weighted trees support a monophyletic Micratheninae including the genera *Xylethrus*, *Micrathena*, and *Chaetacis*. Levi (1985) justified the monophyly of *Chaetacis* by the presence of humps on the cephalothorax, and the

monophyly of *Micrathena* and *Chaetacis* together by various characters, but he did not justify the monophyly of *Micrathena* apart from *Chaetacis*. It is possible, therefore, that *Micrathena* is paraphyletic with respect to *Chaetacis*. If so, *Chaetacis* is just a derived species group of *Micrathena*. That problem aside, we prefer not to include *Encyosaccus* formally in the subfamily Micratheninae, since this placement is not supported by the weighted analysis (Fig. 88). Both weighted and equally weighted analyses also support a monophyletic Gasteracanthinae including the genera *Gastroxya*, *Augusta*, *Macracantha*, *Isoxya*, *Austracantha*, *Togacantha*, *Gasteracantha*, and *Aetrocantha*. Based on the equally weighted analysis, the definition of the subfamily Gasteracanthinae could be extended (clade 32) to include the 'bark mimic' spiders (clade 33; *Caerostris* and *Aspidolasius*). This is, however, not supported by the weighted data (see Fig. 88). When comparing the preferred weighted and equally weighted trees using the command '**compare**' in NONA, characters (43, 47, 48, 59 and 67) referring to gasteracanthoid relationship receive a higher 'fit' on the weighted tree. As mentioned above (under Tree choice), future work on the gasteracanthoid relationship should therefore pay attention to the gasteracanthoid topology in the weighted analysis (Fig. 88).

None of the analyses support the monophyly of a united spiny orb-weaver clade in the strict sense (Gasteracanthinae + Micratheninae), but we prefer to withhold further judgment until the spiny orb-weavers have been analysed in greater detail (Scharff, in prep.). The problem is now better defined; it involves just gasteracanthines, micrathenines, arciines, and the 'bark mimics' (*Caerostris* and *Aspidolasius*). In particular, there seems to be no need to hypothesize rampant simplification of male genitalia (Levi, 1978: 13). *Pronous* and *Enacrosoma* apparently are not at all closely related to spiny orb-weavers or other argiopoid taxa.

Nevertheless, the biology of Gasteracanthinae and Micratheninae, so far as known, is similar. These animals usually spin taut, strong orbs with closely spaced sticky spirals, which Craig (1987) has termed 'high-impact' webs. The animals themselves are strictly diurnal and favour rather conspicuous web sites (again, to humans), and, compared to other araneids, are rather slow-moving predators. Biogeographically, it is interesting to note that Micratheninae are largely New World inhabitants, and Gasteracanthinae largely Old World inhabitants. Considering the early Cenozoic age of many spider genera (Wunderlich, 1986), the Gondwanian breakup should have affected this clade. The close, if not sister-group relationship between these clades may reflect this pattern.

Araneinae

Simon (1892–5) included few genera in his Araneae (*Araneus*, *Eriophora*, *Zygiella*, *Actinosoma* and *Scoloderus*), but a bewildering number of species in *Araneus*. It is perhaps ironic that paraphyly and polyphyly should so afflict Araneidae and Araneinae, and *Araneus* as well. The subfamily and the genus have always been dumping grounds for taxa that could not be assigned to other subfamilies. Petrunkevitch (1928) assigned 100 genera to this subfamily and Brignoli (1983) 129 genera. Levi (1968–92) has done much to solve this problem by defining monophyletic groups and pointing out alternative placements of genera (Levi, 1980a, b, 1983, 1985, 1986a; Levi & Coddington, 1983).

Although the Araneinae as represented in this analysis also contain some odd genera (e.g. *Kaira* and *Scoloderus*), this group of spiders includes the 'typical' araneids:

largely nocturnal, active, fast predators (e.g. *Eriophora*) and spinners of conventional orb-webs. Simon (1892–5) clearly thought so too, as he stuffed nearly the entire subfamily into one genus, *Araneus*. Their gross morphology is fairly uniform as regards modifications of legs, abdomens, and cephalothoraces, but the male and female genitalia are the most complex of the family, and rival anything else known in spiders (Comstock, 1910). The overall structure of their orbs, compared to the rest of the family, is fairly typical with moderate numbers of radii and spirals inclined somewhat from the vertical. At this stage of its delimitation, Araneinae is certainly the most speciose subfamily of Araneidae, and it is not difficult to point out exceptions to any of these generalizations. *Cyclosa* webs are tight meshed and almost always vertical. *Acacesia* spins among the tightest sticky spirals for any spider of its size, usually at an incline from the vertical. The elongate, vertical ladder webs of *Scoloderus* are bizarre (Eberhard, 1975). *Eustala* is a large genus and its webs, what little is known of them, are astonishingly diverse (Eberhard, 1975, 1985a). During the day araneines usually rest in a camouflaged retreat away from the hub. Many genera make use of some sort of signal line that connects the retreat to the hub, although araneines among araneids are not the only orb-weavers to do so. *Zygiella*, which spins an orb with sectors missing on either side of the signal line, is an extreme example. The signal line is a good example of another behavioral feature that may be phylogenetically informative once its distribution is better known.

Basal and distal araneines

Our data identify a heterogeneous group of ‘basal’ araneines including *Scoloderus*, *Acanthepeira*, the ‘*Hypsosinga*’ clade (itself including *Zygiella*), and *Dolophones*, which can be contrasted with a more homogeneous distal lineage of araneines in the strict sense. In general, the basal nodes in Araneinae have more character support in this analysis than distal nodes (Figs 86, 87). Both the ‘hairy carapace clade’ (clade 42) and the ‘terminal apophysis clade’ (clade 43) are each supported by three characters.

Simon’s Araneae (Table 1) is paraphyletic with respect to his Mangoreae, Cycloseae, and Bertraneae. We did not include *Spintharidus*, and so cannot comment on the monophyly of Bertraneae. However, Mangoreae and Cycloseae, as Simon circumscribed them, could apply to higher groups of Araneinae. Cycloseae is polyphyletic by inclusion of *Witiica* (which these data suggest is an argiopoid), but with *Witiica* transferred, Cycloseae could apply to a group of araneine genera. Clade 53 (including *Cyclosa*, *Araniella*, *Eriophora*, and *Verrucosa*) would be one choice if it holds up with further study, but the only support for it is gain of the conductor lobe (8), which is subsequently lost in *Eriophora*. Simon’s Mangoreae (Table 1) is not demonstrably paraphyletic or polyphyletic by our data (*Spilasma* was not included in this study), and Mangoreae could be applied to the smallest group including all of the classical Mangoreae. This would be clade 56 in Figures 82 and 87, supported by a gain of the ‘subterminal apophysis’. However, the homology of this sclerite is still far from certain.

We hesitate to recognize any subdivisions within distal araneines, even informally, as nodes within this lineage have less character support than any other major lineages. Consequently, we saw bewildering numbers of alternative topologies of araneines during previous runs of slightly different data sets (both in terms of characters and taxa). It is worth noting, however, that the topologies of the equally weighted and the weighted analysis are the same. Few clades, and no large ones,

in the distal part of the araneines are supported by more than a single character (Fig. 87). Three pairs of genera consistently appeared, however, in almost all analyses. *Aculepeira*–*Araneus* are supported by the modified second male tibia (1) and the bifid prong of the median apophysis (11). *Eriophora*–*Verrucosa* are supported by the very elongate scape (29). *Wixia*–*Acacesia* are supported by the large fork of the median apophysis (14) and by the stout setae on the male fourth coxae and trochanters (32). Beyond these small groups, and the general observation that in most analyses ‘distal’ araneines stayed distal and ‘basal’ araneines remained cladistically basal, there was little cladistic stability within Araneinae. Future work could profitably take just this subfamily, use *Acanthepeira* or *Scoloderus* as a root, code various genital characters in much more detail, add many more taxa, and probably make greater progress than we have been able to in this more general and less detailed analysis.

Zygiella

Simon (1892–5) considered *Zygiella* (= *Zygia* C. L. Koch, 1834, preoccupied) to be a synonym of *Araneus* and thus a member of his paraphyletic tribe Araneae (Table 1). Based on the eye arrangement, the tapetum structure, the modified paracymbium, the dorsal cymbium and the cone-shaped tibia of the male palp, Levi (1974a, 1986b) placed *Zygiella* among metines in Tetragnathidae. We disagree that the cymbium of *Zygiella* is typically dorsal; it seems as mesal as that of most araneids. Levy (1987) questioned this and suggested an ‘intermediate’ position between Araneinae and Metinae. Lehtinen (1975, 1978) placed *Zygiella* in the metines, but also noted that some species have typical araneine genitalia. Coddington (1990a) argued that palp structure placed the genus in Araneidae. Some *Zygiella* species have a radix, distal hematodocha, and terminal apophysis in the embolic division, characteristics otherwise unique to Araneidae. Other species lack all these features, which calls into question the monophyly of *Zygiella*. Indeed, no really firm synapomorphies define *Zygiella* as presently delimited (Levi, 1974a). Given the exemplars we used, the data of Table 3 support *Zygiella* as an araneid, and place it within the ‘*Hypsosinga*’ clade. During occasional successive weighting runs on earlier versions of the matrix, *Zygiella* moved closer to distal araneines but never outside the araneids. *Zygiella* never fell with Tetragnathidae in any runs of the data. Using the constraint option in PAUP it cost eight extra steps to link *Zygiella* with the Tetragnathidae, (i.e. given the constraint, the minimum tree length was 290). We must conclude that at least the portion of *Zygiella* exemplified by the taxa we examined (Table 2) is indeed araneids.

Character evolution

We lack space to discuss the behaviour of all 82 characters contributing to Figure 82. Instead we have chosen 15 to illustrate character evolution and the history of its study, in Araneidae. Some represent promising or corroborated synapomorphies, others that *a priori* seemed promising but turned out to fit this data set and tree poorly, and finally a few characters that have been the subject of substantial evolutionary speculation in the literature.

Genital and sexual characters

Based on revisionary work (Levi, 1968–92), one would have predicted that several features of the male palp, such as the ‘complex embolic division’ comprising the

radix (16, see above), stipes (19), subterminal apophysis (20), terminal apophysis (22), and embolus cap (23), among other features, should co-vary to define a monophyletic group of araneines. The same could be said for the conductor lobe and paramedian apophysis (8, 18), and endite tooth (45), all presumably aspects of male secondary sexual morphology and behaviour. In most cases this is true. For example, the radix (16, Fig. 89), distal hematodocha (17, Fig. 90), subterminal apophysis (20, Fig. 91), endite tooth (45, Fig. 92) and terminal apophysis (22, Fig. 93) all consistently define large groups of araneid genera (character retention indices ≥ 0.75). The distal hematodocha and terminal apophysis define the same group, and for that reason we give it an informal name, the 'terminal apophysis clade', in Figure 82. If future research corroborates this taxon, it may be worth recognizing formally. Similarly, the endite tooth (45) is corroborated by the gain of a hirsute carapace (41), and one of the gains of the paramedian apophysis (18). Levi (1980a, b, 1983) already pointed out the value of the endite tooth. The clade so defined is called the 'hairy carapace' clade in Figure 82.

Figures 89–93 are typical of relatively 'good' cladistic characters. They are compatible, they nest one within another, and the monophyly of the taxa they define is corroborated by other features. Of course, even 'good' characters show a smattering of homoplasies. However, it is typical of this kind of homoplasy that they do not corroborate each other. Characters 17, 20, and 22 all show some homoplasy, but the homoplasy itself shows no concordant obvious pattern. Different taxa show the independent evolution of each character state. Data like those in Table 3 can therefore show relatively low consistency indices but still provide reasonably well resolved cladistic hypotheses.

On the other hand, the conductor lobe (8, Fig. 94), paramedian apophysis (18, Fig. 95), stipes (19, Fig. 96), and embolus cap (23, Fig. 97) show substantial homoplasy with regard to each other and the rest of the data (retention indices ≤ 0.63). The conductor lobe evolved three times, the paramedian apophysis 4–6 times (depending on optimization), the stipes evolved six times, and the embolus cap three times. The lobe on the conductor of some araneids has been interpreted as representing fusion of the paramedian apophysis to the conductor (Levi, 1985, 1988). Without commenting on its relation to the paramedian apophysis, one can see (Figs 94, 95) that even as an independent character, 'conductor with lobe' contains relatively little phylogenetic information. Together these highly homoplasious characters help to define eight groups on the cladogram (Figs 94–97), but the only significant overlap is between the stipes and embolus cap. The former defines *Neoscona*, *Larinia*, *Aculepeira*, and *Araneus*, and the latter agrees, less *Neoscona*. Another example is the bubble-shaped subterminal apophysis usually thought to be a synapomorphy for *Metazygia* and *Eustala* (Levi, 1977b). The feature is unique to these genera, but they are not sister taxa, and so the character has a retention index (and weight) of zero in Table 3. It costs 10 steps to force the homology of the bubble-shaped subterminal apophysis on Figure 82. The discovery of frequent, relatively trivial, homoplasies suggests that homology hypotheses for these features must be re-examined, and perhaps revised.

The peculiar embolus cap (23) found on the tip of the embolus in virgin males and broken off in the spermathecae of mated females shows the same pattern. It unites *Larinia* with *Aculepeira*–*Araneus*, and pops up, oddly enough, in *Metepeira* and *Argiope*. Structures such as embolus caps obviously are important evidence in discussions of sexual selection (Eberhard, 1985b). Whether such arguments are



Figures 89 & 90. Fig. 89. Character 16, radix, traced on equally weighted tree. Fig. 90. Character 17, distal hematodocha, traced on equally weighted tree.

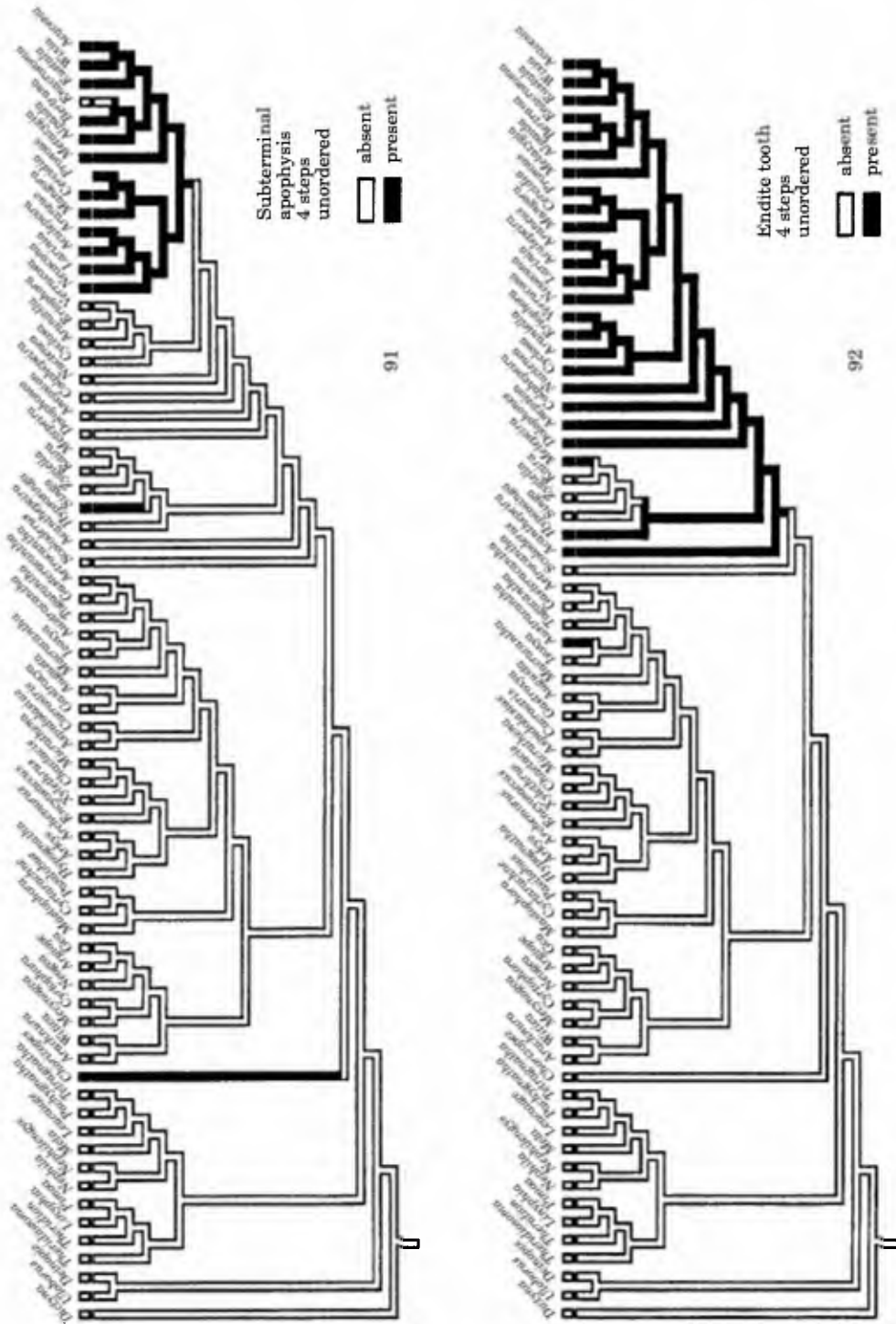

Figures 91 & 92. Fig. 91. Character 20, subterminal apophysis, traced on equally weighted tree. Fig. 92. Character 45, endite tooth, traced on equally weighted tree.



Figures 95 & 96. Fig. 95. Character 18, paramedian apophysis, traced on equally weighted tree. Fig. 96. Character 19, stipes, traced on equally weighted tree.



Figures 97 & 98. Fig. 97. Character 23, embolus tip, traced on equally weighted tree. Fig. 98. Character 33, coxa I hook, traced on equally weighted tree.

relatively supported or contradicted by the finding of widespread convergent evolution in embolus caps is beyond the scope of this paper.

Chorizopes is a striking exception to the trend, noted above, that homoplasy usually is not congruent. Many of the male palpal characters discussed above occur in *Chorizopes*. The specimens we examined had a distal hematodocha (17, Fig. 90), paramedian apophysis (18, Fig. 95), stipes (19, Fig. 96), subterminal apophysis (20, Fig. 91), and terminal apophysis (22, Fig. 93). Even given all these characters classically associated with derived araneines, it costs at least two steps to group *Chorizopes* in Araneinae. This happens because, by and large, the above palpal characters are not particularly congruent with each other, however startling their coincidence in *Chorizopes*. The homoplasious palpal ‘homologies’ offer many places where *Chorizopes* could conceivably go; the result is that it goes nowhere happily.

The coxal hook (33) and femoral groove (34) are also important features in the sexual biology of male spiders. Apparently the features serve to lock together, and perhaps thus to strengthen the anterior legs of the male during mating (Levi, 1983; Robinson & Robinson 1980). Among all taxa examined to date these characters are perfectly correlated, but they also constitute a complex behavioral and morphological mechanism. By including them both we effectively weight the total complex by a factor of two. This method of *a priori* weighting has the virtue of letting complex features weight themselves. Although no other characters define the same node (Fig. 98), it may be worthwhile also to recognize this clade with an informal name, the ‘coxal hook’ clade (Fig. 82). Perhaps other authors will find evidence to corroborate its monophyly. Note that this character complex apparently evolved independently in *Scoloderus*, and three times in the argiopoid clade (Fig. 98). We can provide a crude measure of the difficulty of insisting on the homology of the coxa-femur locking mechanism wherever it occurs. It imposes 12 extra steps on the data of Table 3 to force homology of these two characters. Only by comparing the behaviour of this character against all others can one detect the potential problems in homology posed by its presence in the argiopoid clade. Within the ‘coxal hook’ clade, only *Larinia* lacks the features. As noted above, *Larinia* can also be parsimoniously placed as sister to *Singa*, which makes the ‘coxal hook’ clade even more consistent, a possibility that future workers should bear in mind.

Finally, the scape (28, Fig. 99) is a defining feature of the subfamily Araneinae. Although this feature is difficult to define (note five other gains of ‘scapes’ outside the Araneinae), it is clearly an important part of female sexual biology in this clade. Supposedly, the male median apophysis (or perhaps other parts of the male palp) engage the scape to ‘lock’ the male palp to the female during copulation. Whether the scape serves a mechanical function (Grasshoff, 1968) or a courtship/sexual selection function (Eberhard, 1985b) is a matter of debate. From a phylogenetic perspective at this level, we can only say that apomorphic changes in the median apophysis that we have been able to recognize (e.g. characters 11–15) do not correlate at all with changes in the female scape. The scape has a number of obvious apomorphies (e.g. hugely elongate (29), defining clade 55; with a pocketed tip (30), defining clade 57; and the wrinkled or distensible scape (31), corroborating the ‘hairy carapace’ clade), but none relate obviously to changes in male sexual morphology.

The characters illustrated in Figs 89–99 could not have been identified as ‘good’ or ‘bad’ characters prior to cladistic analysis. Only by assessing their congruence with other characters can problems or confirmation in homology statements be

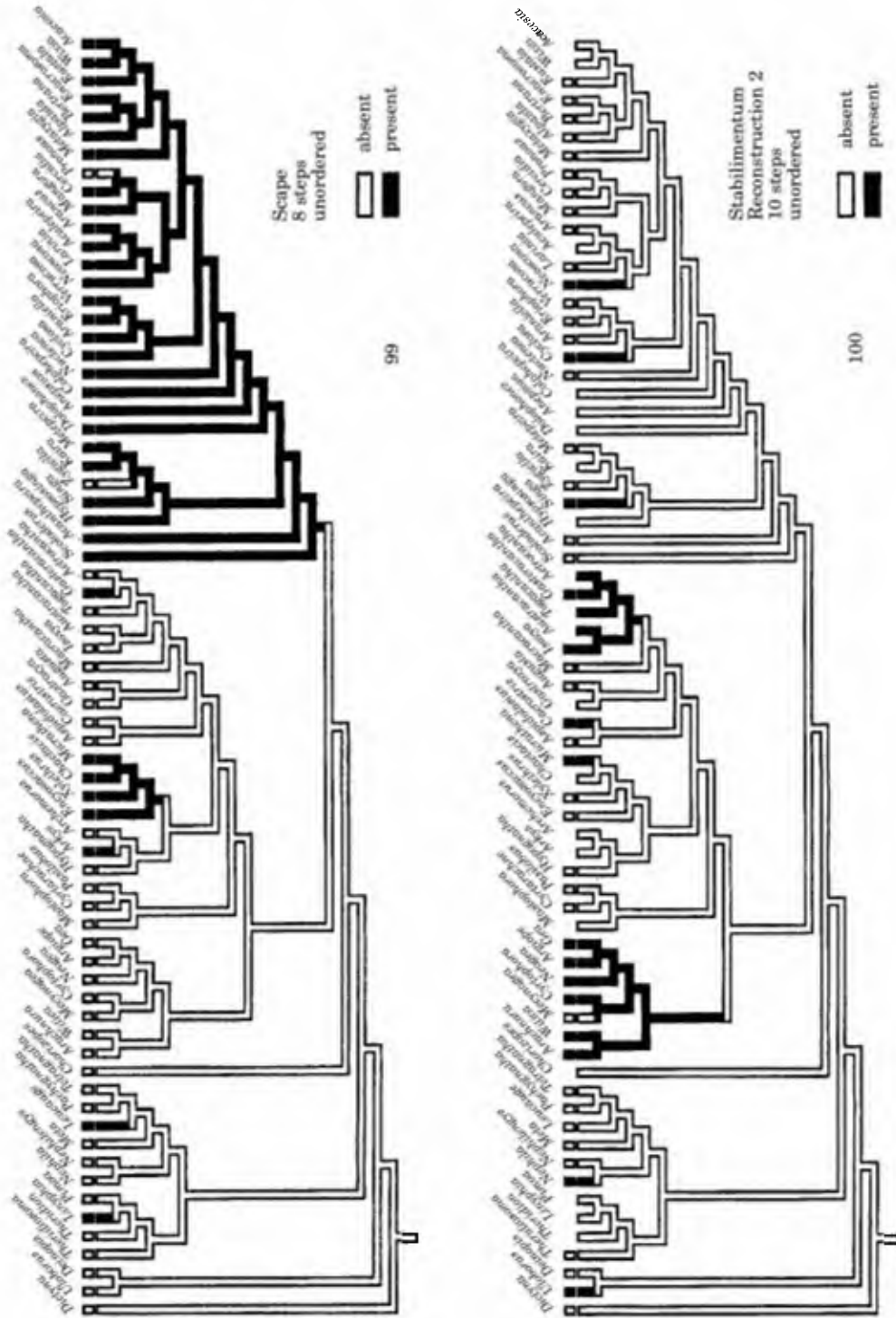

Figures 99 & 100. Fig. 99. Character 2β, scape, traced on equally weighted tree. Fig. 100. Stabilimentum, traced on equally weighted tree. One out of two reconstructions.

discovered. Of course, the topology we present in Figure 82 is not strongly preferred by data over other trees one step longer and the support at many nodes is weak, but trees one step longer require even more conflict in the data. Some characters are distributed so that conflict is inevitable. Realizing that homology hypotheses conflict no matter what the cladogram is, can help to focus definitions of characters.

In this study perhaps the best example of this kind of dilemma concerns the hypothesized relation between the paramedian apophysis (18, Fig. 95) and the lobe on the conductor (8, Fig. 94). The prevalent hypothesis in the literature (Levi, 1976, 1985, 1988, 1992) is that the two features are homologs, and that the lobe is the result of fusion of the paramedian apophysis with the conductor. In cladistic terms, this is equivalent to a three-state ordered character: [lobe and paramedian apophysis absent] evolves to [free paramedian apophysis present] evolves to [paramedian apophysis fused to become a conductor lobe]. Both features do appear in two rather different lineages, distal araneines and gasteracanthines, but the lineages are not exactly congruent. However, Figures 94 and 95 show that the two characters are far from compatible. It costs 24 steps to impose the ordered three-state hypothesis on the data. This is not a completely fair assessment of the cost, as the hypothesis may allow repeated loss to explain homoplasy (Dollo parsimony, Maddison & Maddison, 1992). However, it is certainly clear that homology of conductor lobes and paramedian apophyses is a complex and not particularly parsimonious explanation.

Stabilimentum

Many authors have commented on the evolution of the conspicuous white silk decorations at the hub of orb-webs known as 'stabilimenta' (Craig, 1991, 1994; Craig & Bernard, 1990; Eberhard, 1973, 1990; Eisner & Nowicki, 1983; Lubin, 1975; Nentwig, 1986; Nentwig & Rogg, 1988; Robinson & Robinson, 1970). Most authors accept that 'stabilimenta' in spiders have evolved more than once, but uncertainty about how often and where the stabilimentum may have evolved confuses hypotheses on why it evolved (Edmunds, 1986). We initially included the stabilimentum in the data, but it was clearly uninformative phylogenetically. It was also unscorable for poorly studied genera. Finally we decided to exclude it from the analysis, but to map it on the best fit tree afterwards. On these data, the stabilimentum evolves nine times independently in the 15 genera in which it is known to occur (Fig. 100) and is lost once (in *Mecynogea*). Widespread convergent evolution of a trait invites a search for a common cause underlying the convergent evolution. Many authors hypothesized that stabilimenta offer protection against diurnal predators (Eberhard, 1973; Edmunds, 1986), others that web decorations attract insects and specifically flower foraging insects (Craig, 1991; Craig & Bernard, 1990). If so, then the stabilimentum should have evolved more frequently among orb-weavers that are exclusively diurnal. Stabilimenta, if mapped among araneids, would define the argiopoid clade with a convergence in *Cyclosa*. Except in *Singa*, *Uloborus*, and perhaps *Neoscona*, (which can also be day-active), stabilimenta appear to evolve mainly in taxa that rest at the hub during the day. According to the concentrated changes test as implemented in MacClade 3.0 (Maddison & Maddison, 1992), the association between the two traits is indeed significant. Given the distribution of 'exclusive diurnality', MacClade reports that the probability is 0.0 that the distribution of the nine gains and one loss of stabilimentum (distributed as in Fig. 100) is caused by random factors.

Prey attack behaviour

In a classic paper, Robinson (1975) elaborated a detailed argument for the evolution of attack wrapping in araneid spiders (Fig. 101). Eberhard (1982) distinguished between simple attack-wrapping (the spider simply hurls silk at the prey) and wrapping with rotation (the spider is capable of spinning the prey entangled in the web like a bobbin or fishing reel, thus 'rolling up' the prey with the silk as it is spun). When optimized on Fig. 101 (and ignoring taxa for which the trait cannot be scored), it appears that simple attack wrapping evolved independently in deinopoids and araneoids, and within araneoids, has evolved at least once within tetragnathids, once in the 'argiopine' clade, once in *Caerostris*, and as a synapomorphy for clade 51 (Fig. 82) among araneines. Wrapping with rotation occurs in deinopoids, tetragnathids, *Arachnura*, Argiopinae, and *Metepeira*. Based on a smaller and different set of taxa, Coddington (1986a, 1990a, b) inferred that wrapping of either sort must have been primitive for Orbiculariae, but for these data, the plesiomorphic 'bite' attack is plesiomorphic for Orbiculariae, Araneoidea, and Araneidae. Eberhard (1982) also felt that attack wrapping in deinopoids and araneids was convergent. Of course, the form of the attack is known for so few orbicularian genera that many other scenarios are possible; Figure 101 allows 63 other optimizations of the trait. None of them include homology, and therefore plesiomorphy, at the orbicularian node. Robinson (1975) and Eberhard (1982) agreed that rotational attack-wrapping must have evolved from simple wrapping based on assumptions about presumed adaptive value. The evidence for this evolutionary sequence is equivocal in the 'argiopine clade'. Either state could have been primitive. Elsewhere rotational wrapping evolves directly from the bite attack, contrary to the hypothesis.

Sexual size dimorphism

Sexual size dimorphism (Head, 1995; Hormiga *et al.*, 1995; Vollrath, 1980; Vollrath & Parker, 1992), and the supposedly attendant sexual cannibalism (Elgar, 1991) is another feature of araneid biology to which this phylogenetic reconstruction is relevant. Taking the conventional definition of sexual size dimorphism as females more than twice the size of males, the dimorphic condition evolves three times on Figure 102. The nephilines are, perhaps, the classic case (Hormiga *et al.*, 1995), but the relatively small males of many gasteracanthoids and Cyrtarachninae are also very well known. Cladistically speaking, it is possible to explain dimorphism in these groups with a single 'origin' of the trait at the 'argiopoid' node (clade 15). Coddington (1994) and Hormiga *et al.* (1995) pointed out that sexual size dimorphism is the ratio of two substantially independent traits: male size and female size (Head, 1995). Dimorphism can arise through size change in either sex, and in several ways involving simultaneous or separate size increases and decreases. On Figure 102, however, one can at least say that dimorphism has originated three times (though which sex changed is ambiguous), and has been lost five times (with changes again being ambiguous). MacClade (Maddison & Maddison, 1992) can map continuous variates on cladograms, and, given certain assumptions, reconstruct ancestral values of continuously varying traits. This method offers a way to gain a sharper appreciation of the evolutionary size changes in each sex, although we do not pursue that question here. Suffice it to say that, as in nephilines, most instances of araneid sexual size dimorphism appear to be female giantism rather than male dwarfism, despite the greater effort that theoreticians have devoted to explaining the opposite (e.g. Vollrath & Parker, 1992, and references cited therein).



Figures 101 & 102. Fig. 101. Attack wrap behaviour, traced on equally weighted tree. One out of 64 reconstructions. Fig. 102. Character 61, sexual size dimorphism, traced on equally weighted tree. Abbreviations: ff=females, mm=males.

103

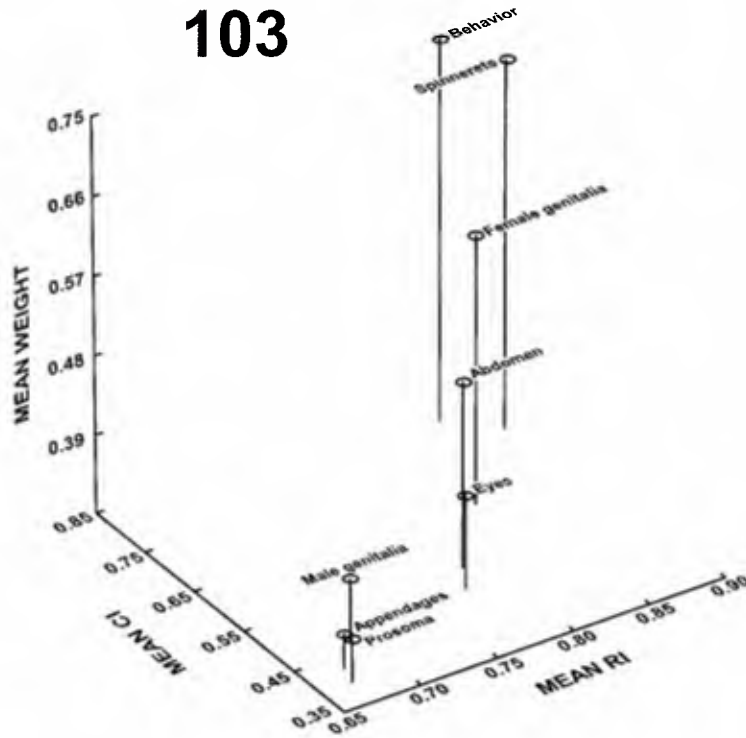

Figure 103. Consilience between eight groups of characters and their fit to the tree. Abbreviations: ci = consistency index, ri = retention index.

Conclusions

An overview of the consilience between different classes of characters (Table 3) and their fit to the tree (Fig. 103) shows some interesting trends. This comparison plots the consistency index against the retention index and against the weight each character received after successive weighting for groups of characters as classified in Table 3. As Figure 103 indicates, the three measures are highly correlated. Behaviour, spinnerets, and female genitalia are more concordant among themselves (and therefore to the best fit tree) than any other classes of characters. Abdominal and eye features are intermediate. Male genitalia, appendage and prosomal features are least concordant. Several of the appendage characters also describe male secondary sexual features (32–34). In this study features of male anatomy, despite their prevalent use in systematics, appear to offer at best a conflicting phylogenetic signal, at least at this taxonomic level.

The matrix of Table 3 and the topology of Figure 82 should permit other workers to use these results to investigate the evolutionary dimension of their own data on Araneidae. The very real conflicts in character distributions, compared to the promise inherent in the richness of araneid biology, shows that the phylogeny of Araneidae is a difficult subject. Perhaps the broad outlines of Figure 82 will prove to be durable. These results present at best a fairly stable picture, and at worst, a small set of alternative topologies, for tribal and subfamilial relationships. Perhaps

half of Simon's original groupings proved 'correct', although of course Figure 82 provides detailed hypotheses of relationships between tribes and subfamilies, whereas Simon proposed none.

Some of the results are controversial. Our more subjective impressions of these results are that, first, *Chorizopes* is probably not the sister group of the remaining Araneidae, but that it is a phylogenetic problem. It falls at the bottom of the araneid cladogram because it lacks a few key features that make it slightly less parsimonious to place it where it probably belongs, that is, among basal araneines. Second, whether the 'argiopine' clade and Cyrtarachninae are more closely related to the 'setal base' clade or to Araneinae is a question that only more data, sharper homology hypotheses, or study of more taxa will settle conclusively. Third, we are skeptical of the details of araneine relationships in Figure 82. Some pairs of taxa are stable and others tend to cluster together although their exact relationships are not stable. For example, it is possible that the rough distinction between basal and distal araneines will endure. It seems clear that *Zygiella* (or at least that portion of the genus exemplified here) is an araneid and not a tetragnathid. *Larinia* may belong as sister to *Singa* after all (Fig. 81). Many more araneine genera could have been scored, but as the matrix already contained too many taxa for the number of characters accepted as informative, adding more taxa may have made any solution even more elusive. We included at least the maximum number of taxa required to permit assessment of the full range of systematic characters in Araneidae that are likely to be informative at the tribal and subfamily level. Certainly more features germane to intergeneric relationships will be discovered. In gasteracanthines alone, several are already known. Using such characters at higher taxonomic levels will depend on more revisionary research. This analysis has already shown that many supposed 'homologies' among araneids need to be re-thought. Future work should focus on refining these discordant homology hypotheses, searching for new characters and data, and making the data matrix more representative of araneid diversity.

ACKNOWLEDGEMENTS

We would particularly and especially like to thank H. W. Levi for providing access to his personal drawings (unpublished) of araneid type specimens. More than that, his 25 years of steady work on Araneidae made this study possible. Without his clear and superbly illustrated revisions of araneid genera, the basic work required for higher-level phylogenetic studies such as this would be unavailable. We also thank him for generously consulting with us and sharing his opinions on araneid phylogeny on numerous occasions throughout this work. W. G. Eberhard kindly corroborated several behavioral characters and G. Hormiga helped with the coding of Pimoidae. Of course the codings for characters are ours and any errors of fact or interpretation that may remain are entirely our responsibility. During an earlier analysis, D. Swofford provided an entire week of time on his Sun workstation, for which we are asymptotically grateful. We thank P. de Place Bjørn, W. G. Eberhard, C. E. Griswold, G. Hormiga, R. Jocqué, H. W. Levi, M. E. Petersen, N. I. Platnick, D. Southard, and M. K. Stowe for comments on earlier drafts.

We would like to thank the following colleagues and institutions from whom we borrowed material: P. M. Croeser, Natal Museum, Pietermaritzburg, South Africa

(NM); M. Grasshoff, Forschungsinstitut Senckenberg, Frankfurt, Germany (FS); J. Gruber, Naturhistorisches Museum, Zoologische Abteilung, Vienna, Austria (NHMV); M. Harvey, Western Australian Museum, Perth, Australia; J. Heurtault and C. Rollard, Muséum National d'Histoire Naturelle, Laboratoire des Arthropodes, Paris, France (MNHN); P. Hillyard, Arachnida and Myriapoda Section, Department of Zoology, The Natural History Museum, London, England (BMNH); R. Jocqué, Musée Royal de l'Afrique Centrale, Tervuren, Belgium (MRAC); T. Kronstedt, Sektionen för Entomologi, Naturhistoriska Riksmuseet, Stockholm, Sweden (NRS); H. W. Levi, Department of Invertebrates, Museum of Comparative Zoology, Harvard University, Cambridge, Massachusetts, USA (MCZ); M. Moritz, Museum für Naturkunde, Zoologische Institut der Humboldt Universität, Berlin, Germany (ZMB); N. I. Platnick, Department of Entomology, American Museum of Natural History, New York, USA (AMNH); D. Silva, Museo de Historia Natural Lima, Peru (MHNL); S. F. Swift, Department of Entomology, Bishop Museum, Honolulu, Hawaii, USA (BM); D. Ubick, Department of Entomology, California Academy of Sciences, San Francisco, USA (CAS); For technical assistance we would like to thank Scott Larcher, Søren Langemark, George Venable (computer illustrations, Figs 1–6, 21, 24, 25, 30, 33, 36), Elaine Hodges (illustrations, Figs 20, 26, 27, 34, 38, 39), Birgitte Rubæk (computer illustrations, Figs 7, 13–16, 19, 22, 29, 37, 40–42, 45), Gert Brovad (photography), Susan Braden (SEM) and Walt Brown (SEM). All other illustrations by the authors.

This study was supported in part by grants from the Danish Natural Science Research Council (N. Scharff: grant nos. 11-7440, 11-8038, 11-9877, 9300106 and 9502155) and grants from the Smithsonian Institution (N. Scharff: Short-Term Fellowship and Suzanne Lieber Erichson Exchange Fellowship; Neotropical Lowlands Program and Biological Diversity of Latin America to J. A. Coddington). The Department of Entomology, National Museum of Natural History, Smithsonian Institution (J. A. Coddington and N. Scharff), and the Department of Entomology, Zoological Museum, University of Copenhagen (N. Scharff), provided working facilities throughout the study.

REFERENCES

- Adams III EN. 1986.** N-trees as nestings: complexity, similarity, and consensus. *Journal of Classification* **3**: 299–317.
- Atchley WR, Anderson, DR. 1978.** Ratios and the statistical analysis of biological data. *Systematic Zoology* **27**: 71–78.
- Atchley WR, Gaskins CT, Anderson D. 1976.** Statistical properties of ratios. I. Empirical results. *Systematic Zoology* **25**: 137–148.
- Bertkau P. 1878.** Versuch einer natürlichen anordnung der spinnen nebst bemerkungen zu einzelnen gattungen. *Archiv für Naturgeschichte* **44**: 351–410.
- Bonnet P. 1945–61.** *Bibliographia Araneorum, vol. I–II*. Toulouse: Douladoure.
- Brignoli P. 1983.** *A catalogue of the Araneae described between 1940 and 1981*. Manchester: Manchester University Press.
- Bristowe WS. 1939.** *The Comity of Spiders, I*. London: Ray Society.
- Bristowe WS. 1941.** *The Comity of Spiders, II*. London: Ray Society.
- Bristowe WS. 1958.** *The World of Spiders*. London: Collins.
- Carpenter DIM. 1988.** Choosing among multiple equally parsimonious cladograms. *Cladistics* **4**: 291–296.
- Chrysanthus F. 1971.** Further notes on the spiders of New Guinea I. Argyopidae. *Zoologische Verhandlungen* **113**: 1–52.

- Coddington JA. 1986a.** The monophyletic origin of the orb-web. In: Shear WA, ed. *Spiders: Webs, behavior, and evolution*. California: Stanford University Press, 319–363.
- Coddington JA. 1986b.** The genera of the spider family Theridiosomatidae. *Smithsonian Contributions to Zoology* **422**: 1–96.
- Coddington JA. 1989.** Spinneret silk spigot morphology: Evidence for the monophyly of orb-weaving spiders, Cyrtophorinae (Araneidae), and the group Theridiidae plus Nesticidae. *Journal of Arachnology* **17**: 71–95.
- Coddington JA. 1990a.** Ontogeny and homology in the male palpus of orb-weaving spiders and their relatives, with comments on phylogeny (Araneocladata: Araneoidea, Deinopoidea). *Smithsonian Contributions to Zoology* **496**: 1–52.
- Coddington JA. 1990b.** Cladistics and spider classification: araneomorph phylogeny and the monophyly of orb-weavers (Araneae: Araneomorphae; Orbiculariae). *Acta Zoologica Fennica* **190**: 75–87.
- Coddington JA. 1994.** The roles of homology and convergence in studies of adaptation. In: Vane-Wright R, Eggleton P, eds. *Phylogenetics and Ecology* London: Linnean Society, 53–78.
- Coddington JA (ed.). 1991.** *Spider literature: A computer bibliography, version 3.0.* (about 24,000 keyworded bibliographic citations, 4 megabytes; can be downloaded from arachnology website on <http://www.ufsia.ac.be/Arachnology/Arachnology.html>).
- Coddington JA, Levi HW. 1991.** Systematics and evolution of spiders (Araneae). *Annual Review of Ecology and Systematics* **22**: 565–592.
- Coddington JA, Scharff N. 1995.** Problems with zero-length branches. *Cladistics* **10**: 415–423.
- Coddington JA, Scharff N. 1996.** Problems with ‘soft’ polytomies. *Cladistics* **12**: 139–145.
- Comstock JH. 1910.** The palpi of male spiders. *Annals of the Entomological Society of America* **3**: 161–185.
- Comstock JH. 1912a.** *The Spider Book*. New York: Doubleday, Page and Company.
- Comstock JH. 1912b.** The evolution of the webs of spiders. *Annals of the Entomological Society of America* **5**: 1–10.
- Craig CL. 1987.** The ecological and evolutionary interdependence between web architecture and web silk spun by orb-web weaving spiders. *Biological Journal of the Linnean Society* **30**: 135–162.
- Craig CL. 1991.** Physical constraints on group foraging and social evolution: observations on web-spinning spiders. *Functional Ecology* **5**: 649–654.
- Craig CL, 1994.** Predator foraging behavior in response to perception and learning by its prey: interactions between orb-spinning spiders and stingless bees. *Behavioral Ecology and Sociobiology* **35**: 45–52.
- Craig CL, Bernard GD. 1990.** Insect attraction to ultraviolet-reflecting spider webs and web decorations. *Ecology* **71**(2): 616–623.
- Dahl F. 1912.** Arachnoidea. In: Korschelt E, ed. *Handwörterbuch der Naturwissenschaften, I*: 485–514. Jena: Verlag von Gustav Fischer.
- Dahl F. 1914.** Die Gasteracanthien des Berliner Zoologischen Museum und deren geographische Verbreitung. *Mitteilungen aus dem Zoologischen Museum in Berlin* **7**: 237–301.
- Davies VT, 1988.** An illustrated guide to the genera of orb-weaving spiders in Australia. *Memoirs of the Queensland Museum* **11**: 273–332.
- Eberhard WG. 1973.** Stabilimenta on the webs of *Uloborus diversus* (Araneae: Uloboridae) and other spiders. *Journal of Zoology* **171**: 367–384.
- Eberhard WG. 1975.** The ‘inverted ladder’ orb-web of *Scoloderus* sp. and the intermediate orb of *Eustala* (?) sp. (Araneae, Araneidae). *Journal of Natural History* **9**: 93–106.
- Eberhard WG. 1977.** Aggressive chemical mimicry by a bolas spider. *Science* **198**: 1173–1175.
- Eberhard WG. 1980.** The natural history and behavior of the bolas spider *Mastophora dizzydeani* sp.n. (Araneidae). *Psyche* **87**: 143–169.
- Eberhard WG. 1982.** Behavioral characters for the higher classification of orb-weaving spiders. *Evolution* **36**: 1067–1095.
- Eberhard WG. 1985a.** The ‘saw toothed’ orb-web of *Eustala* sp. (Araneae, Araneidae) with a discussion of ontogenetic changes in spiders’ web-building behavior. *Psyche* **92**: 105–117.
- Eberhard WG. 1985b.** *Sexual Selection and Animal Genitalia*. Cambridge, Massachusetts: Harvard University Press.
- Eberhard WG. 1990.** Function and phylogeny of spider webs. *Annual Review of Ecology and Systematics* **21**: 341–372.
- Edmunds J. 1986.** The stabilimenta of *Argiope flavipalpis* and *Argiope trifasciata* in West Africa, with a discussion of the function of Stabilimenta. In: Eberhard WG, Lubin YD, Robinson B, eds. *Proceedings of the ninth international congress of Arachnology, Panama 1983*: Washington DC: Smithsonian Institution, 61–71.

- Eisner T, Nowicki S. 1983.** Spider web protection through visual advertisement. Role of the stabilimentum. *Science* **219**: 185–186.
- Elgar MA. 1991.** Sexual cannibalism, size dimorphism, and courtship behavior in orb-weaving spiders (Araneidae). *Evolution* **45**: 444–448.
- Emerit M. 1972.** Vers une phylogénie des gasteracanthés (Araneae, Argiopidae). In: Cestmir Folk ed. *Arachnologorum Congressus Internationalis V, Brno., 1971*. [Proceedings of the Fifth International Congress on Arachnology]. Brno: Institute of Vertebrate Zoology, Czechoslovak Academy of Sciences, 117–122.
- Emerit M. 1973.** Contribution à la connaissance des Araneidae Gasteracanthinae du sud-est africain: les Gasteracanthés du Natal Museum. *Annals of the Natal Museum* **21**: 675–695.
- Emerit M. 1974.** Arachnides, Araignées, Araneidae, Gasteracanthinae. *Fauna de Madagascar* **38**: 1–215.
- Farris JS. 1969.** A successive approximations approach to character weighting. *Systematic Zoology* **18**: 374–385.
- Farris JS. 1988.** *Hennig86, version 1.5*. Computer program distributed by A.G. Kluge, Museum of Zoology, The University of Michigan, Ann Arbor, Michigan 48109-1079, USA.
- Foelix RF. 1982.** *Biology of Spiders*. Cambridge: Harvard University Press.
- Foelix RF. 1992.** *Biologie der Spinnen*. Stuttgart: Thieme.
- Forster RR, Platnick NI. 1984.** A review of the archaeid spiders and their relatives, with notes on the limits of the superfamily Palpimanoidea (Arachnida, Araneae). *Bulletin of the American Museum of Natural History* **178**: 1–106.
- Gerhardt U. 1911.** Studien über die Copulation einheimischer Epeiriden. *Zoologische Jahrbucher. II Abteilung für Systematik* **31**: 643–664.
- Gerhardt U.** Vergleichende Studien über die Morphologie des männlichen Tasters und die Biologie der Kopulation der Spinnen. *Archiv für Naturgeschichte* **A87**: 78–247.
- Gertsch WJ. 1949.** *American Spiders*. New York: D. van Nostrand Company, Inc.
- Gertsch WJ. 1955.** The North American bolas spiders of the genera *Mastophora* and *Agatostichus*. *Bulletin of the American Museum of Natural History* **160**: 225–254.
- Glueck S. 1993.** A taxonomic revision of the orb-weaver genus *Acaesia* (Araneae: Araneidae). *Psyche* **101**: 59–84.
- Goloboff PA. 1993a.** *NONA. Noname ver. 1.15 (a bastard son of Pee-Wee) 32-bit version*. Program and documentation. Computer program available from J. M. Carpenter, Dept. Entomology, American Museum of Natural History, New York, USA.
- Goloboff PA. 1993b.** *Pee-Wee.(P)arsimony and (I)mplied (W)eights ver. 2.15 (32 bit version)*. Program and documentation. Computer program available from J. M. Carpenter, Dept. Entomology, American Museum of Natural History, New York, USA.
- Grasshoff M. 1968.** Morphologische Kriterien als Ausdruck von Artgrenzen bei Radnetzspinnen der Subfamilie Araneinae (Arachnida: Araneae: Araneidae). *Abhandlungen der Senckenbergischen Naturforschenden Gesellschaft* **516**: 1–100.
- Grasshoff M. 1970.** Die gattung *Kilima*. *Senckenbergiana Biologica* **51**: 119–128.
- Grasshoff M. 1973.** Konstruktions- und Funktionsanalyse an Kopulationsorganen einiger Radnetzspinnen. *Aufsätze und Reden senckenbergischen naturforschenden Gesellschaft* **24**: 129–151.
- Grasshoff M. 1974a.** Zur Evolution der Kopulationsorgane der Spinnen. *Natur und Museum* **104**: 55–60.
- Grasshoff M. 1974b.** Transformierungsreihen in der Stammesgeschichte-Mechanischer wandel an Kopulationsorganen von Radnetzspinnen. *Natur und Museum* **104**: 321–356.
- Grasshoff M. 1984.** Die Radnetzspinnen-Gattung *Caerostris* (Arachnida: Araneae). *Revue de Zoologie Africaine* **98**: 725–765.
- Griswold CE. 1993.** Investigations into the phylogeny of the lycosoid spiders and their kin (Arachnida, Araneae, Lycosoidea). *Smithsonian Contributions to Zoology* **539**: 1–39.
- Griswold CE, Coddington JA, Hormiga G, Scharff N. In press.** Phylogeny of the orb-web building spiders (Araneae, Orbiculariae: Deinopoidea, Araneoidea). *Zoological Journal of the Linnean Society*.
- Head G. 1995.** Selection on fecundity and variation in the degree of sexual size dimorphism among spider species (Class Araneae). *Evolution* **49**: 776–781.
- Heimer S. 1982.** Interne Arretierungsmechanismen an den Kopulationsorganen Männlicher Spinnen (Arachnida, Araneae): Ein Beitrag zur Phylogenie der Araneoidea. *Entomologische Abhandlungen der Staatliches Museum für Tierkunde (Dresden)* **45**: 35–64.
- Heimer S. 1984.** Remarks on the genus *Arxys* Walckenaer, 1837, with description of new species

- (Araneae: Mimetidae). *Entomologische Abhandlungen der Staatliches Museum für Tierkunde (Dresden)* **47**: 155–178.
- Heimer S, Nentwig W. 1982.** Thoughts on the phylogeny of the Araneioidea Latreille, 1806 (Arachnida, Araneae). *Zeitschrift für Zoologische Systematik und Evolutionsforschung* **20**: 284–295.
- Heimer S, Nentwig W. 1991.** *Spinnen Mitteleuropas*. Berlin: Paul Parey.
- Hingston RWG. 1927.** Protective devices in spiders' snares, with a description of seven new species of orb-weaving spiders. *Proceedings of the Zoological Society of London*: 259–293.
- Hingston RWG. 1928.** Protective devices in spiders' snares. *Proceedings of the South London Entomological and Natural History Society* 15–17.
- Hingston RWG. 1929.** Spiders: their devices for concealment and protection. *Journal of the East Africa and Uganda Natural History Society* **36**: 149–156.
- Homann H. 1971.** Die Augen der Araneae. Anatomie, Ontogenie und Bedeutung für die Systematik (Chelicerata, Arachnida). *Zeitschrift für Morphologie der Tiere* **69**: 201–272.
- Hormiga G. 1993.** Implications of the phylogeny of Pimoidae (new rank) for the systematics of linyphiid spiders (Araneae, Araneioidea, Linyphiidae). In: Raven R, ed. *Proceedings of the 13th International Congress of Arachnology, Brisbane 1992*, 533–542.
- Hormiga G. 1994a.** Cladistics and the comparative morphology of linyphiid spiders and their relatives (Araneae, Araneioidea, Linyphiidae). *Zoological Journal of the Linnean Society* **111**: 1–71.
- Hormiga G. 1994b.** A revision and cladistic analysis of the spider family Pimoidae (Araneioidea, Araneae). *Smithsonian Contributions to Zoology* **549**: 1–104.
- Hormiga G, Eberhard WG, Coddington JA. 1995.** Web-construction Behavior in Australian *Phonognatha* and the Phylogeny of Nephilinae and Tetragnathid Spiders (Araneae: Tetragnathidae). *Australian Journal of Zoology* **43**: 313–364.
- Jones D. 1983.** *The Country Life Guide to Spiders of Britain and Northern Europe*. Middlesex: Country Life Books.
- Kaston BJ. 1948.** Spiders of Connecticut. *Bulletin of the Connecticut State Geological and Natural History Survey* **70**: 1–874.
- Kaston BJ. 1964.** The evolution of spider webs. *American Zoologist* **4**: 191–207.
- Kaston BJ. 1980.** *How to know the spiders*. Iowa: W.C. Brown Company Publishers.
- Lehtinen PT. 1975.** Notes on the phylogenetic classification of Araneae. *Proceedings of the 6th International Arachnological Congress, Amsterdam 1974*; 26–29.
- Lehtinen PT. 1978.** Definition and limitations of supraspecific taxa in spiders. *Symposium of the Zoological Society of London* **42**: 255–271.
- Levi HW. 1968.** The spider genera *Gea* and *Argiope* in America (Araneae: Araneidae). *Bulletin of the Museum of Comparative Zoology* **136**: 319–352.
- Levi HW. 1970.** Problems in the reproductive physiology of the spider palpus. *Bulletin du Muséum national d'Histoire naturelle de Paris, sér. 2*. **41**: 108–111.
- Levi HW. 1971.** The orb-weaver genera *Singa* and *Hypsosinga* in America (Araneae, Araneidae). *Psyche* **78**: 229–256.
- Levi HW. 1973.** Small orb-weavers of the genus *Araneus* north of Mexico (Araneae: Araneidae) *Bulletin of the Museum of Comparative Zoology* **145**: 473–552.
- Levi HW. 1974a.** The orb-weaver genus *Zygiella* (Araneae: Araneidae). *Bulletin of the Museum of Comparative Zoology* **146**: 267–290.
- Levi HW. 1974b.** The orb-weaver genera *Araniella* and *Nuctenea* (Araneae: Araneidae). *Bulletin of the Museum of Comparative Zoology* **146**: 291–316.
- Levi HW. 1975.** Mating behavior and presence of embolus cap in male Araneidae. *Proceedings of the 6th International Arachnological Congress, Amsterdam 1974*; 49–50.
- Levi HW. 1976.** The orb-weaver genera *Verrucosa*, *Acanthepeira*, *Wagneriana*, *Acacesia*, *Wixia*, *Scoloderus* and *Alpaida* north of Mexico (Araneae: Araneidae). *Bulletin of the Museum of Comparative Zoology* **147**: 351–391.
- Levi HW. 1977a.** The orb-weaver genera *Metepeira*, *Kaira* and *Aculepeira* in America north of Mexico (Araneae: Araneidae). *Bulletin of the Museum of Comparative Zoology* **148**: 185–238.
- Levi HW. 1977b.** The American orb-weaver genera *Cyclosa*, *Metazygia* and *Eustala* north of Mexico (Araneae, Araneidae). *Bulletin of Comparative Zoology* **148**: 61–127.
- Levi HW. 1978.** The American orb-weaver genera *Colphepeira*, *Micrathena* and *Gasteracantha* north of Mexico (Araneae, Araneidae). *Bulletin of the Museum of Comparative Zoology* **148**: 417–442.
- Levi HW. 1980a.** Orb-webs—primitive or specialized. In: Gruber J, ed. *Verhandlungen der 8 Internationaler Arachnologen Kongress, Wien*. Vienna: Verlag H. Engermann, 367–370.

- Levi HW. 1980b.** The orb-weaver genus *Mecynogea*, the subfamily Metinae and the genera *Pachygnatha*, *Glenognatha* and *Azilia* of the subfamily Tetragnathinae north of Mexico (Araneae: Araneidae). *Bulletin of the Museum of Comparative Zoology* **149**: 1–74.
- Levi HW. 1981.** The American orb-weaver genera *Dolichognatha* and *Tetragnatha* north of Mexico (Araneae: Araneidae, Tetragnathinae). *Bulletin of the Museum of Comparative Zoology* **149**: 271–318.
- Levi HW. 1983.** The orb-weaver genera *Argiope*, *Gea* and *Neogea* from the western Pacific region (Araneae, Araneidae, Argiopinae). *Bulletin of the Museum of Comparative Zoology* **150**: 247–338.
- Levi HW. 1985.** The spiny orb-weaver genera *Micrathena* and *Chaetacis* (Araneae: Araneidae). *Bulletin of the Museum of Comparative Zoology* **150**: 429–618.
- Levi HW. 1986a.** The orb-weaver genus *Witica* (Araneae: Araneidae). *Psyche* **93**: 35–46.
- Levi HW. 1986b.** The Neotropical orb-weaver genera *Chrysometa* and *Homalometa* (Araneae: Tetragnathidae). *Bulletin of the Museum of Comparative Zoology* **151**: 91–215.
- Levi HW. 1988.** The Neotropical orb-weaving spiders of the genus *Alpaida* (Araneae: Araneidae). *Bulletin of the Museum of Comparative Zoology* **151**: 365–487.
- Levi HW. 1991.** The Neotropical and Mexican species of the orb-weaver genera *Araneus*, *Dubiepeira*, and *Aculepeira* (Araneae: Araneidae). *Bulletin of the Museum of Comparative Zoology* **152**: 167–315.
- Levi HW. 1992.** The Neotropical orb-weaver genera *Edricus* and *Wagneriana* (Araneae: Araneidae). *Bulletin of the Museum of Comparative Zoology* **152**: 363–415.
- Levi HW, Coddington JA. 1983.** Progress report on the phylogeny of the orb-weaving family Araneidae and the superfamily Araneoidea (Arachnida: Araneae). *Verhandlungen Naturwissenschaftlichen Vereines in Hamburg, (NF)* **26**: 151–154.
- Levy G. 1987.** Spiders of the genera *Araniella*, *Zygiella*, *Zilla* and *Mangora* (Araneae, Araneidae) from Israel, with notes on *Metellina* species from Lebanon. *Zoologica Scripta* **16**: 243–257.
- Locket GH, Millidge AF. 1951.** *British Spiders* vols. I and II. London: Ray Society.
- Lopez A, Emerit M. 1986.** Présomption en faveur de glandes et phéromones chez des mâles de Metidae (Araneae). *Bulletin de la Société d'Étude des Sciences naturelles Béziers (NS)*, **9**(52): 56–60.
- Lubin YD. 1975.** Stabilimenta and barrier webs in the orb-webs of *Argiope argentata* (Araneae, Araneidae) on Daphne and Santa Cruz Islands, Galapagos. *Journal of Arachnology* **2**: 119–126.
- Maddison WP. 1989.** Reconstructing character evolution on polytomous cladograms. *Cladistics* **5**: 365–377.
- Maddison DR. 1991.** The discovery and importance of multiple islands of most-parsimonious trees. *Systematic Zoology* **40**: 315–328.
- Maddison WP, Maddison DR. 1992.** *MacClade: Interactive analysis of phylogeny and character evolution. Version 3.0.* Sunderland, Massachusetts: Sinauer Associates.
- Maddison WP, Donoghue MJ, Maddison DR. 1984.** Outgroup analysis and parsimony. *Systematic Zoology* **33**: 83–103.
- Main BY. 1982.** Notes on the reduced web, behaviour and prey of *Argys nitidiceps* Simon (Araneidae) in southwestern Australia. *Bulletin of the British arachnological Society* **5**: 425–432.
- Marples BJ. 1969.** Observation on decorated webs. *Bulletin of the British arachnological Society* **1**: 13–18.
- Mascord RE. 1966.** The mating behavior of *Gasteracantha minax* Thorell, 1859 (Araneida: Argiopidae). *Journal of the Entomological Society of Australia, N.S.W.* **3**: 44–47.
- McCook HC. 1889–1894.** *American Spiders and their Spinningwork, vols. 1–3.* Philadelphia.
- Mello-Leitão C. de. 1931.** Contribuição ao estudo da tribu Mastophoreas. *Annales de la Academia Ciencias Rio de Janeiro* **3**: 65–74.
- Millidge AF. 1977.** The conformation of the male palpal organs of linyphiid spiders, and its application to the taxonomic and phylogenetic analysis of the family (Araneae: Linyphiidae). *Bulletin of the British arachnological Society* **4**: 1–60.
- Müller HG. 1984.** Beiträge zur Spinnenfauna von Hessen-Faunistik, Autokologie und Phanologie. 1. Pholcidae, Dysderidae, Segestriidae, Uloboridae, Tetragnathidae, Metidae und Nesticidae (Arachnida: Araneida). *Hessische faunistische Briefe 4(3). Berichte der Naturwissenschaftlichen Vereines zu Darmstadt N.F.* **8**: 38–47.
- Nemenz H. 1963.** Die Kutikula und Kutikulastrukturen von *Gasteracantha cauciformis* (L., 1758) (Araneae: Araneidae, Gasteracanthinae). *Zeitschrift für wissenschaftliche Zoologie* **169**: 82–119.
- Nentwig W. 1986.** Stabilimente in Radnetzen von *Argiope*-Arten (Araneae: Araneidae): ein funktionsloses Relikt? *Verhandlungen der deutschen zoologischen Gesellschaft Münster* **79**: 182.
- Nentwig W, Rogg H. 1988.** The cross stabilimentum of *Argiope argentata* (Araneae: Araneidae)—nonfunctional or a nonspecific stress reaction? *Zoologischer Anzeiger* **221**: 248–266.
- Nielsen E. 1932.** *The biology of spiders*, vol. II. Copenhagen: Levin and Munksgaard.

- Nixon KC.** 1992. *Clados ver. 1.2*. Program and documentation. Distributed by author, P.O. Box 270, Trumansburg, NY 14886, USA.
- Opell B.** 1979. Revision of the genera and tropical American species of the spider family Uloboridae. *Bulletin of the Museum of Comparative Zoology* **148**: 443–547.
- Palmgren P.** 1978. On the muscular anatomy of spiders. *Acta Zoologica Fennici* **15**: 1–41.
- Petrunkovitch A.** 1928. Systema Araneorum. *Transaction of the Connecticut Academy of Arts and Sciences* **29**: 1–270.
- Platnick NI.** 1989a. *Advances in spider taxonomy 1981–1987*. A supplement to Brignoli's *A catalogue of the Araneae described between 1940 and 1981*. Manchester and New York: Manchester University Press.
- Platnick NI.** 1989b. An empirical comparison of microcomputer parsimony programs, II. *Cladistics* **5**: 145–161.
- Platnick NI.** 1993. *Advances in spider taxonomy 1988–1991, with synonymies and transfers 1940–1980*. New York: New York Entomological Society.
- Platnick NI, Shadab MU.** 1993. A review of the pirate spiders (Araneae: Mimetidae) of Chile. *American Museum Novitates* **3074**: 1–30.
- Platnick NI, Levi HW.** 1973. On family names of spiders. *Bulletin of the British arachnological Society* **2**: 166–167.
- Platnick NI, Griswold CE, Coddington JA.** 1991. On missing entries in cladistic analysis. *Cladistics* **7**: 337–343.
- Reimoser E.** 1917. Die Spinnengattung *Micrathena* Sundevall. *Verhandlungen der Zoologisch-Botanischen Gesellschaft in Wien* **67**: 73–160.
- Roberts MJ.** 1985. *The spiders of Great Britain and Ireland, Vol. 1: Atypidae to Theridiosomatidae*. Colchester, England: Harley Books.
- Roberts MJ.** 1995. *Spiders of Britain and Northern Europe*. London: Harper Collins Publishers.
- Robinson MH.** 1969. Predatory behavior of *Argiope argentata* (Fabricius). *American Zoologist* **9**: 161–173.
- Robinson MH.** 1975. The evolution of predatory behavior in araneid spiders. In: Baerends G, Beer C, Manning A, eds. *Function and evolution in behavior*. Oxford: Clarendon Press, 292–312.
- Robinson MH.** 1982. The ecology and biogeography of spiders in Papua New Guinea. *Monographiae Biologicae* **42**: 557–581.
- Robinson MH, Olazarri J.** 1971. Units of behavior and complex sequences in the predatory behavior of *Argiope argentata* (Fabricius) (Araneae: Araneidae). *Smithsonian Contributions to Zoology* **65**: 1–36.
- Robinson MH, Robinson R.** 1970. The stabilimentum of the orb-web spider *Argiope argentata*: an improbable defense against predators. *Canadian Entomologist* **102**: 641–655.
- Robinson MH, Robinson B.** 1973. Ecology and behavior of the Giant Wood Spider *Nephila maculata* (Fabricius) in New Guinea. *Smithsonian Contributions to Zoology* **149**: 1–76.
- Robinson MH, Robinson B.** 1974. The biology of some *Argiope* species from New Guinea: predatory behavior and stabilimentum construction (Araneae: Araneidae). *Zoological Journal of the Linnean Society* **54**: 145–159.
- Robinson MH, Robinson B.** 1975. Evolution beyond the orb-web: the web of the araneid spider *Pasilobus* sp., its structure, operation and construction. *Zoological Journal of the Linnean Society* **56**: 301–314.
- Robinson MH, Robinson B.** 1980. Comparative studies of the courtship and mating behavior of tropical araneid spiders. *Pacific Insect Monographs* **36**: 1–218.
- Roewer CF.** 1942. *Katalog der Araneae*. 1. band. Bremen: Natura.
- Roth VD, Roth BM.** 1984. A review of appendotomy in spiders and other arachnids. *Bulletin of the British arachnological Society* **6**: 137–146.
- Sanderson MJ, Donoghue MJ.** 1989. Patterns of variation in levels of homoplasy. *Evolution* **43**: 1781–1785.
- Scharff N.** 1990. Spiders of the family Linyphiidae from the Uzungwa Mountains, Tanzania (Araneae). *Entomologica Scandinavica Supplement* **36**: 1–95.
- Shear WA.** 1994. Untangling the evolution of the web. *American Scientist* **82**: 256–266.
- Simon E.** 1890. Études Arachnologiques XXXIV. Études sur les Arachnides de l'Yemen. *Annales de la Société entomologique de France* **6**: 77–124.
- Simon E.** 1892–1895. *Histoire naturelle des Araignées I*. Paris: Librairie Encyclopédique de Roret.
- Stowe MK.** 1986. Prey specialization in the Araneidae. In: Shear WA, ed. *Spiders: Webs, Behavior and Evolution*. Stanford, California: Stanford University Press, 101–131.
- Swofford DL.** 1993. *PAUP: Phylogenetic Analysis Using Parsimony, Version 3.1*. Computer program distributed by Illinois State Natural History Survey, Champaign, Illinois.

- Swofford DL, Maddison WP. 1987.** Reconstructing ancestral character states under Wagner parsimony. *Mathematical Biosciences* **87**: 199–229.
- Termonia Y. 1994.** Molecular modeling of spider silk elasticity. *Macromolecules* **27**: 7378–7381.
- Uetz GW. 1986.** Web building and prey capture in communal orb-weavers. In: Shear WA, ed. *Spiders: Webs, Behavior and Evolution*. California: Stanford University Press, 207–231.
- Vollrath F. 1980.** Why are spider males small? A discussion including observations on *Nephila clavipes*. In: Gruber J, ed. Proceedings of the 8th International Congress of Arachnology, Vienna, 165–169.
- Vollrath F, Parker GA. 1992.** Sexual dimorphism and distorted sex ratios in spiders. *Nature* **360**: 156–159.
- Vollrath F. 1988.** Untangling the spider's web. *Trends in Ecology and Evolution* **3**: 331–335.
- Vollrath F. 1990.** Leg regeneration in web spiders and its implications for orb-weaver phylogeny. *Bulletin of the British arachnological Society* **8**: 177–184.
- Vollrath F. 1992.** Spider webs and silks. *Scientific American*, March 1992, 70–76.
- Wiehle H. 1931.** Neu Beiträge zur Kenntnis des Fanggewebes der Spinnen aus den Familien Argiopidae, Uloboridae und Theridiidae. *Zeitschrift für Morphologie und Ökologie der Tiere* **23**: 349–400.
- Wilkinson M. 1994.** Common cladistic information and its consensus representations: Reduced Adams and reduced cladistic consensus trees and profiles. *Systematic Biology* **43**: 343–368.
- Wilkinson M. 1995.** Arbitrary resolutions, missing entries, and the problem of zero-length branches in parsimony analysis. *Systematic Biology* **44**: 108–111.
- Witt PN, Reed CF, Peakall DB. 1968.** *A spider's web. Problems in regulatory biology*. Berlin: Springer Verlag.
- Witt PN, Scarboro MB, Daniels R, Peakall DB, Gause RL. 1976.** Spider web-building in outer space: evaluation of records from the Skylab spider experiment. *Journal of Arachnology* **4**: 115–124.
- Work R. 1976.** The force elongation behavior of web fibers and silks forcibly obtained from orb-web-spinning spiders. *Textile Research Journal* **46**: 485–492.
- Wunderlich J. 1986.** *Spinnenfauna Gestern und Heute. Fossile Spinnen in Bernstein und ihre heute lebenden Verwandten*. Wiesbaden: Erich Bauer Verlag bei Quelle and Meyer.
- Wunderlich J. 1991.** Die Spinnen-Fauna der Makaronesischen Inseln. Taxonomie, Ökologie, Biogeographie und Evolution. *Beiträge zur Araneologie* **1**: 1–619.
- Yaginuma T. 1986.** *Spiders of Japan in color*. Osaka, Japan: Hoikusha Publishing Co.
- Yeargan KV. 1994.** Biology of the bolas spiders. *Annual Review of Entomology* **39**: 81–99.
- Yu LM, Coddington JA. 1990.** Ontogenetic changes in the spinning fields of *Nuctenea cornuta* and *Neoscona theisi* (Araneae, Araneidae). *Journal of Arachnology* **18**: 331–345.

APPENDIX. CHARACTER MAPPINGS AND APOMORPHY LISTS

Below, we optimize all characters on the preferred tree of length 282 (Fig. 82). The evaluation deals with each clade in numerical order. Clades are identified by the numbers attached to the internodes of the cladograms in Figures 82–87. If optimizations are ambiguous we used accelerated transformation to resolve the ambiguity (ACCTRAN), thus preferring secondary loss rather than parallel gain as an explanation for homoplasy. This option consistently biases interpretation towards homology over convergence. In the diagnoses that follow, we have listed only the unambiguous support at each node, unless only ambiguous support is available, in which case it is so noted.

Clade 1 (Orbiculariae). The monophyly of orbicularians is supported by three synapomorphies: male palpal patella with macrosetae (4); subsequently lost in *Deinopis*, theridiids, *Mastophora*, *Kaira*, and clades 17 and 34, presence of serrate accessory claw setae (39), and the presence of an orb-web (74; subsequently lost in *Chorizopes*, *Mastophora*, and clades 6 and 28).

Clade 2 (Deinopoidea). The monophyly of Deinopoidea is supported by five synapomorphies: posterior median eyes with canoe tapetum lost (51; parallel loss in clade 12), posterior lateral eyes without canoe-shaped tapetum (53; parallel loss in *Tetragnatha*), feathery hairs (55), median spinneret paracribellars of deinopoid morphology (71), and ready posture at hnb with legs 1 and 2 extended (82; parallel origin in clade 10, and *Larinia*).

Clade 3 (Araneoidea). The monophyly of Araneoidea is supported by 4 synapomorphies: the presence of a paracymbium (6; subsequently lost in *Theridion* and *Caerostris*), the glabrous carapace (41; subsequently reversed to hirsute in *Nephilengys* and in clades 16, 32 and 42), the loss of a cribellum (68), and the presence of minor ampullate nubbins on the median spinnerets (72; subsequently lost in *Archemorus* and in clade 6).

Coddington (1990b) listed another 7 synapomorphies for Araneoida. Five of these were spinneret characters and one concerned setal structure, all of which require SEM to ascertain character states. Since we did not carry out detailed SEM studies on the taxa included here, we cannot comment on the mapping of these potential synapomorphies.

Clade 4. The 'derived' araneoids (Griswold *et al.*, in press; Coddington, 1990a) including only linyphiids, pimoids, theridiosomatids, theridiids and tetragnathids in this reduced data set are supported by two characters: the reduction of the aciniform brush of the median spinnerets (73, subsequently reversed in *Meta*, and with parallel reduction in clades 27 and 61), localization of SS by use of inside first leg = 'L1' (78).

Clade 5. *Theridiosoma*, *Theridion*, *Linyphia*, and *Pimoida*, are united by reduced piriform spigot bases on the anterior spinnerets (69).

Clade 6. *Theridion*, *Linyphia*, and *Pimoida* are supported by two synapomorphies: the absence of minor ampullate mubbins on the medium spinnerets (72; parallel loss in *Archemorus*), and the loss of the orb-web (74; parallel loss in *Chorizopes*, *Mastophora*, and in clade 28).

Clade 7. *Linyphia* and *Pimoida* are supported by two synapomorphies: the presence of tibial autospasy (36) and the stridulation files on the margins of the chelicerae (44).

Clade 8 (Tetragnathidae): The tetragnathids (here represented by *Nephila*, *Nephilengys*, *Tetragnatha*, *Pachygnatha*, *Meta*, and *Leucauge*) are supported by three synapomorphies: a conductor that wraps the embolus (9), the loss of the median apophysis of the male palp (10; parallel loss in *Dictyna*, *Linyphia*, *Witica*, *Mecynogea*, and *Dolophones*), and grooved booklung covers (64; parallel origin in *Deinopis* and clade 14).

Clade 9 (Nephilinae): *Nephila* and *Nephilengys* are united by four synapomorphies: sexual dimorphism (61; parallel origin in *Kaira* and clade 15), the uniquely derived nephiline radius behaviour (76), non-sticky spiral in the web is left untouched when the spider constructs the sticky spiral (77; parallel origin in clade 19), and SS localization by extending the fourth leg = 'L4' (78).

Clade 10. *Meta*, *Leucauge*, *Pachygnatha*, and *Tetragnatha* are supported by one synapomorphy: ready posture at hub with L1 and L2 extended (82; parallel origin in *Larinia* and clade 2).

Clade 11. *Leucauge*, *Pachygnatha*, and *Tetragnatha* are supported by two synapomorphies: fourth femora with a number of dorsal trichobothria (35; parallel origin in *Uloborus*), and booklung covers reversed to normal (smooth surface) (64).

Clade 12 (Tetragnathinae). *Tetragnatha* and *Pachygnatha* are united by four synapomorphies: the globular tegulum (7), the haplogyne female genitalia (25), the absence of a female epigynum (26), and the loss of the canoe-shaped tapetum in the posterior median eyes (51; parallel loss in clade 2).

Clade 13 (Araneidae). The family Araneidae are well defined and supported by four synapomorphies: the mesal orientation of the male palpal cymbium (5, subsequently reversed in *Zygiella*), the presence of a radix in the male palp (16, subsequently lost in *Caenostis* and *Neogea*), the wide distance between the median and lateral eyes (50; subsequently lost in *Cyrtarachne*, clade 18 and 43), and posterior median eyes with a narrow tapetum (52).

Traditionally, the family Araneidae is divided into a number of subfamilies (Araneinae, Cyrtophorinae, Gasteracanthinae, Micratheninae, Argiopinae and Cyrtarachninae (or Mastophorinae). This study suggests two major evolutionary araneid lineages that we will call Araneinae (clade 41) and the 'argiopoid' clade (clade 15).

Clade 14. All araneids except *Chorizopes* are united by two synapomorphies: the presence of a sustentaculum (40; subsequently lost in *Austracantha*, *Bertrana*, clade 24, 26, 35 and 40) and grooved booklung covers (64; parallel origin in *Deinopis* and clade 8).

Clade 15 ('argiopoid clade'): The 'argiopoid clade' includes taxa that have traditionally been placed in the subfamilies Cyrtophorinae, Argiopinae, Gasteracanthinae, Micratheninae, and Cyrtarachninae. It is only supported by a single synapomorphy: the size dimorphism between males and females (61; parallel origin in *Kaira* and clade 9).

Clade 16. Argiopinae, Cyrtophorinae, *Arachnura* and *Witica* are supported by one synapomorphy: the hirsute carapace (41; parallel reversal in *Nephilengys*, clade, 32 and 42).

Clade 17. *Arachnura* and *Witica* are supported by one synapomorphy: macrosetae of male palpal patella lost (4; parallel loss in *Deinopis*, *Theridion*, *Mastophora*, *Kaira*, and clade 34).

Clade 18. The monophyly of Argiopinae and Cyrtophorinae is supported by one synapomorphy: median and lateral eyes close together (50).

Clade 19 (Cyrtophorinae). Simon's classical Cyrtophorinae (*Cyrtophora* and *Mecynogea*) is supported by four synapomorphies: embolus runs in an anticlockwise direction (24; parallel origin in *Theridiosoma*, *Witica*, and *Zygiella*), piriform field of anterior spinnerets reduced to narrow ribbon (70), orb-web without sticky spiral (75), and persistent non-sticky spiral in web (77; parallel origin in clade 9).

Clade 20. The subfamily Argiopininae (*Argiope*, *Gea* and *Neogea*) is supported by three synapomorphies: the threadlike spur on the median apophysis (12), the reduction of the canoe-shaped tapetum in the posterior lateral eyes (53), and the procurved posterior eyes (54; parallel origin in clade 28).

Clade 21. *Argiope* and *Gea* are united by one synapomorphy: the presence of a stipes (19, parallel origins in *Chorizopes*, *Eustala*, *Eriophora*, clades 44 and 58). Another possible synapomorphy was suggested by Per de Place Bjorn (pers. comm.), who found a broken-off embolus tip of an unidentified *Gea* from Africa. The tip is very similar in morphology to that found in the genus *Argiope*.

Clade 22. This clade comprises taxa that Simon placed in the subfamilies Gasteracanthinae, Micratheninae, Arciinae, and the tribes Cyrtarachneae and Glyptocraneae. The clade is supported by two synapomorphies: abdomen with sigillae (56; parallel origin in *Dolophones*), and female abdomen wider than long (60; reversed to longer than wide in *Arkys*, and in clade 31; parallel origin in *Dolophones*, *Verrucosa*, and clade 65).

Clade 23 (Cyrtarachninae). The subfamily Cyrtarachninae (*Mastophora*, *Cyrtarachne* and *Pasilobus*) are supported by two synapomorphies: the very sticky SS (80) and the extreme LA combing (81).

Clade 24. The genera *Cyrtarachne* and *Pasilobus* are united by two synapomorphies: the loss of the sustentaculum (40; parallel loss in *Austracantha*, *Bertrana*, and clades 26, 35, and 40) and the presence of low-shear sticky lines in the web (79).

Clade 25 ('setal base clade'). This clade is supported by three synapomorphies: cephalon rectangular (wider than long) in dorsal view (47; reversed to normal in clade 30), cephalon abnormally higher than thorax (48; reversed to normal in clade 30; parallel origin in *Theridiosoma*, *Nephilengys*, *Acanthepeira*, *Hypsosinga*, *Verrucosa*, and *Euacrosoma*), and setal bases on carapace and abdomen swollen and of characteristic shape (67; parallel origin in *Chorizopes*).

Clade 26. This clade is supported by one synapomorphy: the lost sustentaculum (40; regained in *Micrathena*; parallel loss in *Austracantha*, and in clades 24, 35, and 40).

Clade 27. This clade comprises genera that were originally considered araneids by Simon, but later transferred to other families. It is supported by two synapomorphies: sexual dimorphism lost (61; parallel loss in *Mecynogea*, *Gea*, and in clades 31 and 38), and aciniform brush on median spinnerets reduced (73; parallel reduction in clades 4 and 61).

Clade 28. *Arkys* and *Archemorus* are supported by four synapomorphies: radix lost (16; parallel loss in *Neogea* and in clade 33), posterior row of eyes procurved (54; parallel origin in clade 20), abdominal sigillae of female abdomen in 2 rows (57; parallel origin in clade 35), and orb-web lost (74; parallel loss in *Mastophora*, *Chorizopes*, and in clade 6).

Clade 29 ('micrathenines'). This clade is supported by two synapomorphies: lobe on male palpal conductor (8; parallel origin in clades 53 and 63), and the presence of a scape (28; parallel origin in *Linyphia*, *Leucauge*, *Arkys*, *Gasteracantha* and clade 41).

Clade 30 (Micratheninae). The subfamily Micratheninae (including *Xylethrus*, *Chaetacis* and *Micrathena*) is supported by three synapomorphies: cephalon reversed from rectangular shape to normal shape (47), cephalon reversed to normal height (48), and spiracle on sclerotized ring or on sclerites that surround spinnerets (66; parallel origin in *Hypognatha* and in clade 34).

Clade 31. The genera *Micrathena* and *Chaetacis* are supported by four synapomorphies: sigillae on abdomen scattered (57; parallel origin in *Caerostris* and *Cyrtarachne*), shape of female abdomen reversed to normal (i.e. longer than wide) (60; parallel reversal in *Arkys*), sexual dimorphism lost (61; parallel loss in *Mecynogea*, *Gea*, and clades 27 and 38), and booklung covers with stridulating file (63).

Clade 32 ('gasteracanthoid clade'). The gasteracanthoid clade is supported by two synapomorphies: a reversal to a hirsute carapace (41; parallel reversal in *Nephilengys*, and clades 16 and 42), and female carapace wider than long (42; reversed to longer than wide in *Gastroxya* and *Austracantha*).

Clade 33. *Aspidolasius* and *Caerostris* are supported by only one synapomorphy: the lost radix (16; parallel loss in *Neogea* and in clade 28).

Clade 34 (Gasteracanthinae). The subfamily Gasteracanthinae is supported by five synapomorphies: the absence of male palpal patella macrosetae (4; parallel loss in *Kaira*, *Mastophora*, *Deinopis*, *Theridion*, and in clade 17), the presence of paramedian apophysis (18; parallel origin in *Chorizopes* and clade 42), a star-shaped male abdomen (59), a female abdomen with three pairs of spines (62), and the spiracle on the female abdomen on a sclerotized ring or on the sclerites that surround the spinnerets (66; parallel origin in *Hypognatha* and clade 30).

Clade 35. *Gastroxya* and *Augusta* are supported by four synapomorphies: male palpal femur with macrosetae (3); median apophysis of male palp with transparent triangular flap (13), sustentaculum lost (40; parallel loss in *Bertrana*, *Austracantha*, and clades 24, 26, and 35), and female with two rows of abdominal sigillae (57; parallel origin in clade 28).

Clade 36. This clade is supported by one synapomorphy: metatarsi with many trichobothria (37; parallel origin in *Witica*, *Mastophora*, *Caerostris*, *Dolophones*, *Cyclosa*, *Eriophora*, and *Alpaida*).

Clade 37. This clade is supported by one synapomorphy: female abdomen with ventral condyles (58; parallel origin in *Gastrovya*).

Clade 38. *Isoxya* and *Austracantha* are supported by four synapomorphies: coxae I of males with a hook (33; parallel origin in *Scoloderus*, *Hypognatha*, *Micrathena*, and in clade 49; lost in *Lariniä*), femora II of males with grooves (34; parallel origin in *Scoloderus*, *Hypognatha*, *Micrathena*, and in clade 49; lost in *Lariniä*), male carapace quadrangular (43; parallel origin in *Aspidolasius* and in clade 27), and sexual dimorphism lost (61; parallel loss in *Mecynogea*, *Gea*, clades 27 and 31).

Clade 39. *Togacantha*, *Gasteracantha* and *Aetrocantha* are supported by one synapomorphy: spinnerets surrounded by sclerites (65; parallel origin in clade 30).

Clade 40. *Gasteracantha* and *Aetrocantha* are supported by three synapomorphies: presence of a genital tubercle between spinnerets and epigynum (27), sustentaculum lost (40; parallel loss in *Austracantha*, and clades 24, 26, and 35), and male abdomen U-shaped (59).

Clade 41 (Araneinae). The subfamily Araneinae is supported by two synapomorphies: male palpal femora with tubercles (3; parallel origin in *Austracantha*; subsequently lost in *Nuctenea*, and in clades 46 and 61), and the presence of a scape (28; parallel origin in *Linyphia*, *Leucauge*, *Arkys*, *Gasteracantha*, and clade 29; subsequently lost in *Zygiella* and *Pronous*).

Clade 42 ('hairy carapace clade'). This clade is supported by two synapomorphies: a hirsute carapace (41; parallel reversal in clades 16 and 32), and the presence of an endite tooth (45; parallel origin in *Austracantha*; subsequently lost in clade 45).

Clade 43 ('terminal apophysis clade'). This clade is supported by three synapomorphies: male palp with a distal hematodocha (17; parallel origin in *Chorizopes*; subsequently lost in *Araniella*, *Pronous*, and in clade 64), male palp with a terminal apophysis (22; parallel origin in *Chorizopes* and *Mecynogea*), and separation between lateral eyes and median eyes reversed to normal (= narrow separation) (50; parallel reversal in *Cyrtarachne* and in clade 18).

Clade 44 ('*Hypsosinga* clade'). This clade is supported by one synapomorphy: male palp with a stipes (19; parallel origin in *Chorizopes*, *Eriophora*, *Eustala*, and in clades 21 and 58; subsequently lost in clade 47).

Clade 45. This clade is supported by two synapomorphies: endite tooth lost (45) and shape of median ocular area narrower in front than behind (49; parallel origin in *Arachnura*, *Cyrtophora*, *Hypognatha*, *Encyosaccus*, and in clade 51).

Clade 46. *Zygiella*, *Kaira* and *Metepeira* are supported by one synapomorphy: tubercle on male femora lost (3; parallel loss in *Nuctenea* and in clade 61).

Clade 47. *Kaira* and *Metepeira* are supported by three characters: median apophysis of male palp provided with a bifid prong (11; parallel origin in clade 60), anterior margin of median apophysis toothed (15; parallel origin in *Aculepeira*), and stipes of male palp lost (19).

Clade 48. This clade is supported by one synapomorphy: scape wrinkled (31; parallel origin in *Metepeira*).

Clade 49 ('coxal hook clade'). This clade is supported by two synapomorphies: male coxae I with hooks (33; parallel origin in *Scoloderus*, *Hypognatha*, *Macracantha*, and in clade 38; subsequently lost in *Lariniä*), and femora II with grooves (34; parallel origin in *Scoloderus*, *Macracantha*, *Hypognatha* and in clade 38; subsequently lost in *Lariniä*).

Clade 50. This clade is supported by ambiguous support only: paramedian apophysis of male palp lost (18).

Clade 51. This clade is supported by one synapomorphy: median ocular area wider in front than behind (49; subsequently reversed in *Pronous* and in clade 66).

Clade 52. This clade is supported by one synapomorphy: macrosetae on Tibiae II of males stronger and more robust than those of Tibia I (2; parallel origin in *Scoloderus* and *Austracantha*; subsequently reversed in *Araniella*, *Lariniä*, *Enacrosoma*, and *Alpaida*).

Clade 53. This clade is supported by one synapomorphy: male palpal conductor with lobe (8; parallel origin in clades 29 and 63; subsequently lost in *Eriophora*).

Clade 54. *Araniella*, *Eriophora* and *Verrucosa* are supported by two synapomorphies: tibiae of the second pair of legs modified (1; parallel origin in clade 60), and lateral eyes widely separated from median eyes (50; parallel origin in *Alpaida* and in clade 13).

Clade 55. *Eriophora* and *Verrucosa* are supported by one synapomorphy: epigynum with elongate scape (29).

Clade 56. This clade is supported by one synapomorphy: male palp with subterminal apophysis (20; parallel origin in *Chorizopes* and *Singa*; subsequently lost in *Enacrosoma*).

Clade 57. This clade is supported by one synapomorphy: epigynal scape with pockets near tip (30; parallel origin in *Linyphia*, *Arkys*, *Singa*, *Araniella*, and in clade 65; subsequently lost in *Aculepeira*).

Clade 58. This clade is supported by one synapomorphy: male palp with a stipes (19; parallel origin in *Chorizopes*, *Eriophora*, *Eustala*, and in clades 21 and 44).

Clade 59. *Larinia*, *Aculepeira*, and *Araneus* are supported by one synapomorphy: embolus of male palp provided with a cap at the tip (23; parallel origin in *Argiope* and *Metepeira*).

Clade 60. *Aculepeira* and *Araneus* are supported by two synapomorphies: tibiae of the second pair of legs in males are modified (1; parallel origin in clade 54), and median apophysis of male palp with bifid prong (11; parallel origin in clade 47).

Clade 61. *Cercidia* and *Pronous* are supported by two synapomorphies: tubercle on male palpal femur lost (3; parallel loss in *Nuctenea* and in clade 46), and median spinnerets with aciniform brush reduced (73; parallel reduction in clades 27 and 4).

Clade 62. This clade is supported by one synapomorphy: scape of female epigynum reversed to smooth (31; parallel reversal in *Anepsion* and *Neoscona*).

Clade 63. This clade is supported by one synapomorphy: conductor of male palp with lobe (8; parallel origin in clades 53 and 29; subsequently lost in *Acacesia*).

Clade 64. *Alpaida*, *Bertrana*, and *Enacrosoma* are supported by one synapomorphy: distal haematodocha of male palp lost (17; parallel loss in *Araniella* and *Pronous*).

Clade 65. *Bertrana* and *Enacrosoma* are supported by two synapomorphies: scape of female epigynum provided with a pocket at the tip (30; parallel origin in *Linyphia*, *Arkys*, *Singa*, *Araniella*, and in clade 57), and a female abdomen that is wider than long (60; parallel origin in *Verrucosa*, *Dolophones*, and in clade 22).

Clade 66. *Eustala*, *Wixia*, and *Acacesia* are supported by one synapomorphy: median ocular area reversed to narrower in front than behind (49; parallel reversal in *Pronous*).

Clade 67. *Wixia* and *Acacesia* are supported by two synapomorphies: Median apophysis of male palp with distal fork (14), and coxa and trochanter IV of males provided with short stout macrosetae (32).