

# Variation in the Mitochondrial Control Region in the Juan Fernández Fur Seal (*Arctocephalus philippii*)

S. Goldsworthy, J. Francis, D. Boness, and R. Fleischer

The Juan Fernández fur seal (*Arctocephalus philippii*) was allegedly extremely abundant, numbering as many as 4 million prior to sealing which continued from the late 17th to the late 19th century. By the end of the sealing era the species was thought to be extinct until they were rediscovered at Alejandro Selkirk Island in 1965. Historic records would suggest that the species underwent a substantial population bottleneck as a result of commercial sealing, and from population genetic theory we predicted that the genetic variability in the species would be low. We compared the mtDNA control region sequence from 28 Juan Fernández fur seals from two islands in the Juan Fernández Archipelago (Chile). Contrary to expectation, we found that variation in the Juan Fernández fur seals is not greatly reduced in comparison to other pinniped taxa, especially given the apparent severity of the bottleneck they underwent. We also determined minor, but significantly different haplotype frequencies among the populations on the two islands (Alejandro Selkirk and Robinson Crusoe Islands), but no difference in their levels of variability. Such differences may have arisen stochastically via a recent founder event from Alejandro Selkirk to Robinson Crusoe Island or subsequent genetic drift.

Population genetic theory makes clear quantitative predictions of the reductions in genetic variability expected from population declines or bottlenecks (Nei et al. 1975; Wright 1931). Populations that are reduced to small size and subsequently experience rapid growth lose relatively less variation than populations that do not grow rapidly (Maruyama and Fuerst 1985). Molecular genetic markers can be used to test the predictions of population genetic theory in studies of both laboratory and natural populations (e.g., Hoelzel et al. 1993; Leberg 1992; Tarr et al. 1998). While controlled laboratory studies can directly demonstrate the effects of population bottlenecks on allelic diversity and heterozygosity, it is important to assess what actually happens in natural populations that have been greatly decreased in size. Many natural populations have experienced well-documented, human-caused declines. Marine mammals, including pinnipeds, have suffered particularly extreme reductions in population size from the impacts of overhunting during previous centuries (Bonnell and Selander 1974; Busch 1985; Hoelzel et al. 1993). With worldwide protection established early in this century, many of these impacted populations began and are still continuing to recover

(Bester 1987; Boyd 1993; Guinet et al. 1994; Hofmeyr et al. 1997; Shaughnessy and Goldsworthy 1990). However, in many cases the populations remained small for long periods of time because of continued hunting pressure. Highly polygynous pinniped species may have been especially impacted by bottlenecks because the extreme skew in mating success (Boness 1991) reduces effective population size and thus the ability of a population to retain genetic variation.

The Juan Fernández fur seal (*Arctocephalus philippii*) is limited in range to the islands that make up the Juan Fernández Archipelago (Alejandro Selkirk, Robinson Crusoe, and Santa Clara) and the San Felix group (San Félix and San Ambrosio) (Torres 1987) (Figure 1). The Juan Fernández Archipelago is about 650 km west of Valparaíso, Chile, and the San Felix group lies about 900 km further north (Figure 1). Early accounts of the Juan Fernández fur seal on both Alejandro Selkirk and Robinson Crusoe Islands during the late 1600s and early 1700s estimate the number of seals in the millions, perhaps exceeding four million in number at the end of the 17th century [see Hubbs and Norris (1971) for a review]. Intensive exploitation of fur seals that began in the late 1600s resulted

From the National Zoological Park, Smithsonian Institution, Washington, DC 20008. S. Goldsworthy is currently at the Zoology Department, La Trobe University, Bundoora, Victoria, Australia. J. Francis is currently at the Committee for Research and Exploration, National Geographic Society, Washington, DC. Hugo Ochoa, Mansol Sepulveda, and Hernán Díaz helped with sample collections in the field. We thank Carl McIntosh, Eleni Paxinos, and Sabine Loew for help with analysis of samples. We acknowledge the Smithsonian Institution, Friends of the National Zoo, and the National Geographic Society (grants 3707-87 and 3979-88) for funding support. Address correspondence to Robert C. Fleischer at the address above or e-mail: rlfleischer@nnp.si.edu.

© 2000 The American Genetic Association 91:371–377

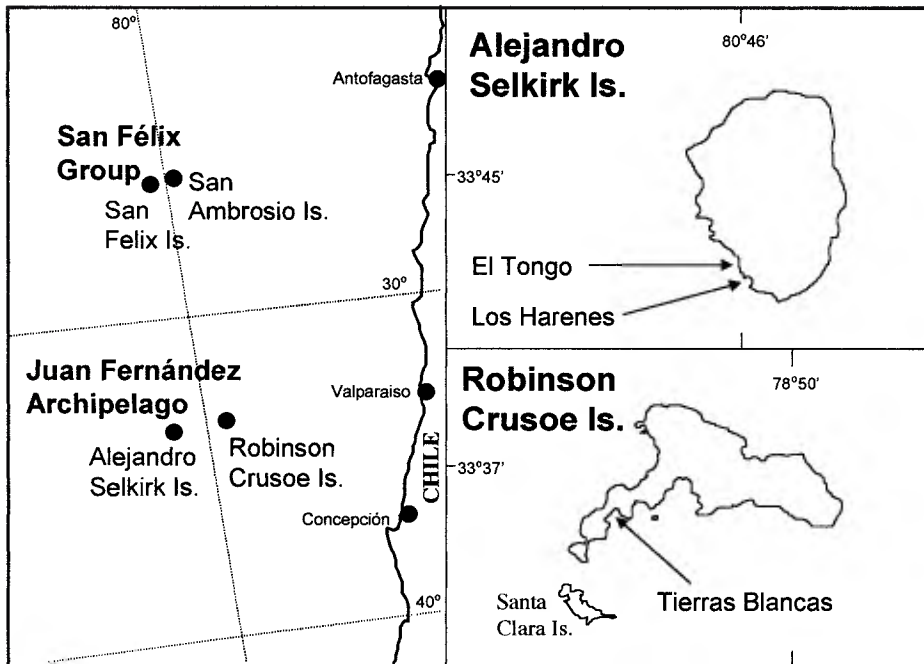

**Figure 1.** Location of the Juan Fernández Archipelago and San Félix group (Chile) and the sites on Alejandro Selkirk and Robinson Crusoe Islands where samples were collected.

in near extinction by the late 1800s (Hubbs and Norris 1971; Torres 1987). For nearly 100 years the species was thought to be extinct until 1965, when Bahamonde (1966) observed about 200 seals on Alejandro Selkirk Island.

Since 1965 the population has grown steadily at nearly 15% per year, with recent estimates of more than 20,000 animals (J. Francis, unpublished data). The status of the Juan Fernández fur seal in the San Félix group at the cessation of sealing is unknown, as the fur seals on these islands have rarely been surveyed. Although about 300 fur seals were counted during a partial census of San Ambrosio Island in 1977 (Torres 1987), whether this is a breeding population is unknown. Breeding of the Juan Fernández fur seal has, however, been confirmed on both Alejandro Selkirk and Robinson Crusoe Islands. That the period of recovery was protracted (nearly 100 years) suggests that the population was reduced to very low numbers toward the end of the 18th century. Based on the intensity and extent of this putative population bottleneck, and the predictions of population genetic models, we hypothesized that the Juan Fernández fur seal should exhibit levels of genetic variation that are low relative to nonbottlenecked species of pinnipeds. Alternatively, in spite of this significant range contraction the species may have survived in refugia in caves or on inacces-

sible beaches, thereby maintaining populations and greater genetic diversity than expected.

Here we assess sequence variation in the mitochondrial DNA (mtDNA) control region of 28 Juan Fernández fur seals and 3 subantarctic fur seals (*Arctocephalus tropicalis*) sampled in the Juan Fernández Archipelago. The aims of this study were to assess the genetic variation in Juan Fernández fur seals in comparison to nonbottlenecked species and predictions of the bottleneck and refugia hypotheses, and to examine whether the current breeding populations of Juan Fernández fur seals on Alejandro Selkirk and Robinson Crusoe Islands are significantly differentiated in order to assess if one or both populations survived the sealing era.

## Materials and Methods

### Study Site and Sampling

Samples of *A. philippii* blood were collected from pups at two islands within the Juan Fernández Archipelago, Chile: two breeding sites on Alejandro Selkirk Island [El Tongo (ET) and Los Harenes (LH)] and one site (Tierras Blancas) on Robinson Crusoe Island (RC) (Figure 1). Three adult female subantarctic fur seals (*A. tropicalis*), were also sampled from Los Harenes on Alejandro Selkirk Island. DNA sequences derived from these individuals were used as outgroups for some analy-

ses. Blood (5–10 ml) was obtained from the interdigital veins of the rear flippers, stored in lysis buffer, and frozen at a later date.

### Laboratory Methods

DNA was isolated in the laboratory using standard phenol-chloroform extraction and ethanol precipitation. We amplified extracted DNA using the polymerase chain reaction (PCR), with oligonucleotide primers homologous to the tRNAs on either side of the mtDNA control region, 5'-TTCCCGGTCTTGTAACC-3' (T-Thr) and 5'-ATTTTCAGTGTCTTGCTT-3' (T-Phe) as per Hoelzel and Green (1992) and Hoelzel et al. (1993). DNA was amplified in 50  $\mu$ l reactions containing 2  $\mu$ l of 0.1–0.5  $\mu$ g genomic DNA, 5  $\mu$ l 10 $\times$  buffer (0.1 M Tris-HCl, pH 8.5, 0.025 M MgCl<sub>2</sub>, 0.5 M KCl), 5  $\mu$ l dNTP mix (2 mM dATP, dTTP, dCTP, dGTP, in 0.1 M Tris-HCl, pH 7.9), 3  $\mu$ l of a 10  $\mu$ M solution of each primer, 0.3  $\mu$ l *Taq* DNA polymerase, and 26.7  $\mu$ l deionized water. The cycle profile was 2 min at 94°C, 2 min at 50°C, and 45 s at 70°C, repeated 30 times. PCR products were cleaned using the QIAquick protocol and cycle sequenced using ABI PRISM<sup>®</sup> dye terminators (ABI 1995) with the T-Thr primer, and an additional internal control-region primer (SCR-1, 5'-CCTGAAGTAAGAACCAGATG-3') (Hoelzel et al. 1993). Sequencing was performed on an ABI 373 automated sequencer (Applied Biosystems 1994).

### Sequence Analysis

Sequences were aligned using Sequencer 3.0 (Gene Codes Corporation 1995) and alignment gaps were also checked by eye. We calculated basic statistics of sequence variation, including the number of distinct haplotypes, haplotype diversity ( $H$ ), mean proportion of segregating sites ( $p$ ), and nucleotide diversity ( $\pi$  and 95% confidence limits; Nei 1987) using the computer programs NucDiversity 1.0a (C. E. McIntosh, unpublished, available from the authors) and Arlequin 2.0b2 (Schneider et al. 1999). We compared  $\pi$  as an estimate of  $\theta$  ( $\theta = 2N_e\mu$ ) to estimates based on  $p$  ( $\theta_p$ ).  $\theta_p$  and its 95% confidence limits were estimated using equations 10.3 and 10.2 (Nei 1987). Mean statistics were calculated across the entire sample, by island, and by collecting site. We used PAUP\* (Swofford 1997) to obtain a matrix of Tamura-Nei and  $\Gamma$ -corrected distances [ $\alpha$  was estimated from the topology of a neighbor-joining tree using the method of Sullivan et al. (1996)]. We used the program ClProgram (C. E. McIntosh, unpub-



**Table 2. Sample size, mean number of segregating sites,  $\theta$  calculated from  $p$ , and nucleotide diversity ( $\pi$ ) for each island and sampling site**

Island	<i>N</i>	<i>p</i>	$\theta_p$ (95%CI)	$\pi$ (95% CI)
Selkirk (combined)	19	0.105	0.030 (0.011–0.049)	0.029 (0.022–0.036)
El Tongo	7	0.067	0.027 (0.000–0.054)	0.030 (0.018–0.041)
Los Harenes	12	0.096	0.032 (0.007–0.056)	0.030 (0.020–0.039)
Robinson Crusoe	9	0.080	0.029 (0.003–0.055)	0.028 (0.017–0.039)

clude base substitutions. Seven of these indel sites occur within a string of 3–10 T bases within the range of bases 115–125 (Table 1). The mean number of segregating sites is 0.156 across all 320 sites (i.e., gaps included) and 0.125 across sites with substitutions alone. The latter value results in an estimate of  $\theta p$  of 0.032 (95% confidence range is 0.015–0.049). The gene diversity ( $H$ ) is  $0.905 \pm 0.034$ , and the nucleotide diversity ( $\pi$ ) is 0.030 (95% confidence range is 0.024–0.036). Tajima's  $D$  is  $-0.048$ , and is not significantly different from zero ( $P = .50$ ). For the three subantarctic fur seal sequences we found 2 haplotypes and 16 variable sites. Even though the sample is small, variability is not low:  $p = 0.051$ ,  $\theta p = 0.034$ , and  $\pi = 0.034$ . Variability does not differ significantly among islands or populations of the Juan Fernández fur seal as measured by  $\pi$  or by  $\theta p$  (Table 2). The observed mismatch distribution of Juan Fernández fur seal sequences differs from the simulated Poisson expectation for a unimodal expansion model ( $P < .02$ ; Figure 2; Harpending 1994). The

mean raggedness index (Harpending 1994) is not particularly large, but is significantly different from zero ( $r = 0.047$ ,  $P < .01$ ). These measurements support the hypothesis that the population size of Juan Fernández fur seals has been stationary or mildly bottlenecked and do not support a historical population expansion (Harpending 1994).

The subantarctic and Juan Fernández fur seals sequences have 21 fixed alternative differences: 14 are transitional differences and 7 are transversal (no gaps occur as fixed differences between the two species) (Table 1). Variable substitutions are also not randomly distributed across the sequence (Figure 3). Only one of these substitutions (position 29) is found in 44 bases of tRNA<sup>pro</sup> compared to 66 of 276 sites in the control region. In addition, sites 149–179 are completely conserved, and the 5' half of the control region's left domain has twice the variable sites found in the 3' half (44 versus 22,  $\Gamma = 9.8$ ,  $P < .005$ ).

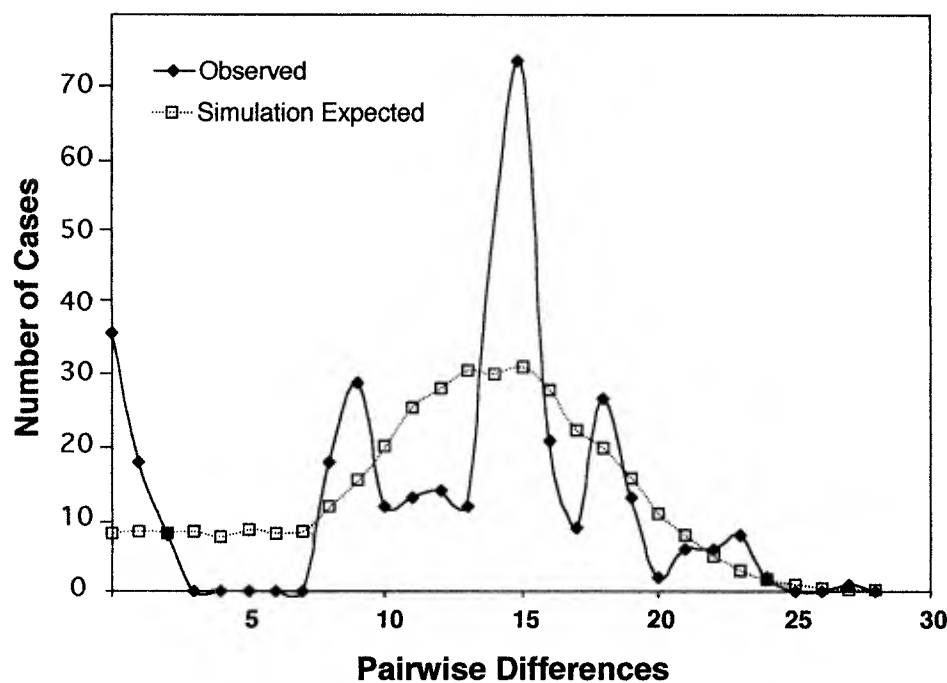

**Figure 2.** Observed mismatch distribution of the 28 Juan Fernández fur seal control region sequences (filled diamonds) and Poisson expectation (open squares).

## Genetic Structure and Phylogeography

The genetic divergence between fur seal populations on Robinson Crusoe and Alejandro Selkirk Islands is significantly different from zero: the uncorrected distance is 0.031, a 95% Jukes–Cantor corrected confidence interval via Steel et al. (1996) method is 0.020–0.044, and the Tamura–Nei and  $\Gamma$ -corrected distance is 0.035 [ $\alpha = 0.468$  by the Sullivan et al. (1996) method]. The AMOVA provides an  $F_{ST}$  of 0.082 between the two island populations (Excoffier 1995). This value is significantly different ( $P = .049$ ) from a null distribution obtained from 100 random permutations. Using equation 13.79 (Nei 1987) we calculate an estimate of  $N_e m$  corrected for a small number of population samples as 1.4.

Phylogenetic relationships among the 13 haplotypes were reconstructed using distance parsimony (minimum evolution) and cladistic parsimony analyses. The distance method utilized a matrix of Tamura–Nei and  $\Gamma$ -corrected distances. Only one minimum evolution tree was found from 10 searches with different taxon orders (minimum evolution score = 0.377; Figure 4). Repeated cladistic branch and bound searches retained the same 12 most-parsimonious trees. Each required 124 steps and provided a consistency index of 0.69. A majority rule consensus constructed from the 12 trees is very similar in topology to the tree derived from minimum evolution (as shown in Figure 4). Node support from 500 repetition bootstraps is also similar between the two analytical methods. Examination of the tree reveals that some haplotypes are found in more than one population or island, and there is only minor structuring of haplotypes into clades. However, although there are haplotypes shared between the two island populations, the AMOVA does provide some evidence of significant, albeit minor, structuring in the Juan Fernández fur seal populations based on mtDNA.

## Discussion

### The Putative Population Decline and Genetic Variation

The Juan Fernández fur seal was impacted from unconstrained hunting to the point where the species was thought to be extinct from the late 1890s until 1965 (Torres 1987). However, some breeding population(s) apparently survived in the Juan Fernández Archipelago (Hubbs and Norris 1971), and perhaps in the San Felix group also. Based on the putatively low popula-

**Table 3. Comparison of the mtDNA control region variation among nine species of pinniped**

Species	Haplotypes/ individuals (populations)	Variable sites/total sites <sup>a</sup> (%)	Pairwise uncorrected distance	Source
Juan Fernández fur seal ( <i>A. philippii</i> )	13/28 (1)	39/313 (12.5%)	0.034	1
Guadalupe fur seal ( <i>A. townsendi</i> )	7/25 (1)	18/313 (5.7%)	0.016–0.036	2
Antarctic fur seal ( <i>A. gozello</i> )	25/47 (1)	58/291 (19.9%)	0.038	3
Subantarctic fur seal ( <i>A. tropicoides</i> )	7/8 (1)	36/291 (12.4%)	0.048	3
Steller sea lion ( <i>Eumetopius jubatus</i> )	52/224 (2)	29/238 (12.2%)	0.017	4
California sea lion ( <i>Zalophus californianus</i> )	11/40 (4)	29/319 (9.2%)	0.011–0.014 0.040–0.053	5
Southern elephant seal ( <i>Miroungo leonino</i> )	26/48 (2)	26/300 (8.7%)	0.023	6
	19/37 (5)	28/444 (6.3%)		7
Northern elephant seal ( <i>Miroungo ongstirostrus</i> )	2/40 (1)	3/300 (1.0%)	0.010	6
Hawaiian monk seal ( <i>Monachus schauinslandi</i> )	3/50 (5)	2/359 (0.6%)	0.0007	8

1, this study; 2, Bernardi et al. (1998); 3, Goldsworthy et al. (unpublished data); 4, Bickham et al. (1996); 5, Maldonado et al. (1995); 6, Hoelzel et al. (1993); 7, Slade (1997); 8, Kretzmann et al. (1998).

<sup>a</sup> Calculated excluding sequence gaps.

tion size of the species for a period that is likely greater than 50–100 years, we predicted that mtDNA variation would be low relative to other pinniped species (e.g. Bickham et al. 1996; Hoelzel et al. 1993). Alternatively the difficult access by boats of certain sites (e.g., beaches and caves) may have resulted in an underestimate of the minimum population size (Francis JM, personal observation). Our observation of relatively high levels of genetic diversity in the Juan Fernández fur seal as measured by nucleotide sequence of the mitochondrial control region supports the refugia hypothesis over the bottleneck hypothesis. We identified 13 haplotypes from 28 individuals, with half of the individuals sharing one of three haplotypes. The genetic variability found in the Juan Fernández fur seal is within the range reported

for the same gene in other pinnipeds, and is much higher than the variation reported in the northern elephant seal and Hawaiian monk seal, both species which share historically documented extreme population size reductions and low genetic diversity (Table 3). The genetic variability found in the Juan Fernández fur seal is greater than that reported for the closely related Guadalupe fur seal (*A. townsendi*), but less than that reported for Antarctic and subantarctic fur seals (Table 3).

By combining historical data with simulation models based on demographic data, Hoelzel et al. (1993) estimated the extent of the population bottleneck that affected the northern elephant seals to be less than 30 seals over a 20-year period, or a single-year bottleneck of less than 20 seals. Such a bottleneck followed by ge-

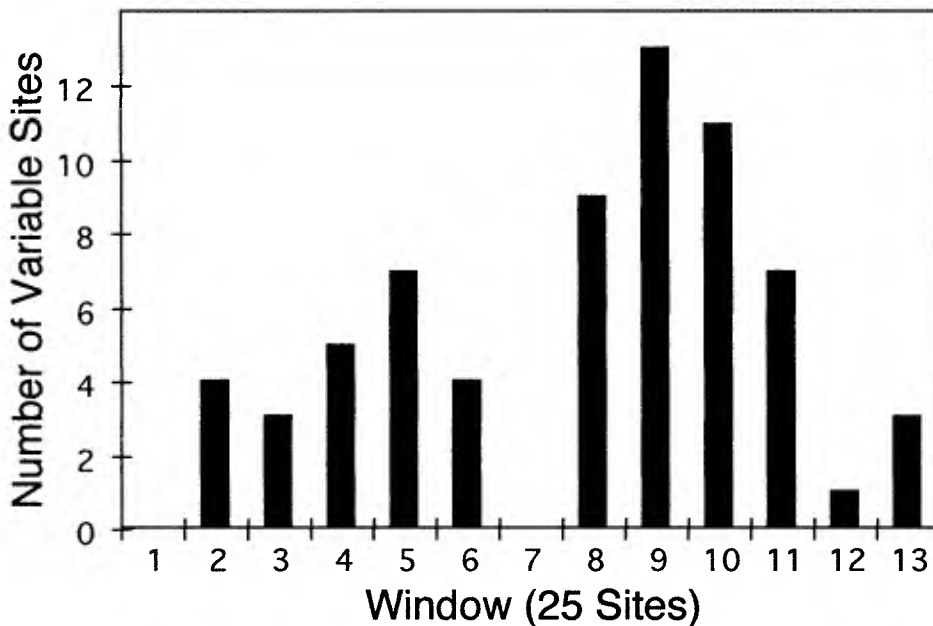

**Figure 3.** Window analysis of variable sites across the control region left domain (from MEGA, Kumar et al. 1995).

netic drift has resulted in a substantial loss of genetic variability, with only two haplotypes in 300 bp of the control region mtDNA (Hoelzel et al. 1993). This contrasts markedly with the southern elephant seal, which, although it was also hunted, was never reduced to such low numbers and has 26 haplotypes for the same region of mtDNA (Hoelzel et al. 1993).

Despite being thought to have a similar population history to the northern elephant seal, the Juan Fernández fur seal does not appear to have the expected low genetic variation. In addition, parameters that can be used to infer bottlenecks (or directional selection) that we estimated from the sequence data do not suggest that a major bottleneck occurred (i.e., Tajima's *D*, mismatch distribution, raggedness index). How can we reconcile the reported severe population decline of the Juan Fernández fur seal with the genetic data? Historical records even suggest the species was extinct by the late 1800s, and the recovery in this century has been extremely slow.

We suggest two likely reasons for this discrepancy between history and genetic diversity: first, although Juan Fernández fur seals were hunted in large numbers from the late 1600s through to the early 1800s (with ships departing the islands with tens of thousands of skins each visit), visits to the islands were less frequent during the 1800s. This was likely a consequence of fewer seals and a decline in demand for fur seal skins as a result of a collapse in the fur seal markets of China, which occurred after 1807 (Richards 1994). Second, some sites where fur seals bred, such as caves or narrow rock ledges at the base of cliffs, would have been mostly inaccessible to sealers and thus provide some refuge. Unlike elephant seals, which breed on sandy beaches, move slowly on land, and are easily approached, fur seals breeding on narrow rocky ledges or caves would have been very difficult to approach, and working in such areas would have been dangerous. Thus declining seal numbers, declining markets for skins, reduced visitation, and a number of refuge areas would have tended to extend the period of population reduction, and ensured that fur seal numbers would not reach critical levels. Such a scenario would reduce the intensity of a population bottleneck, and may explain the relatively high levels of genetic variability in the Juan Fernández fur seal.

Furthermore, the original estimates of

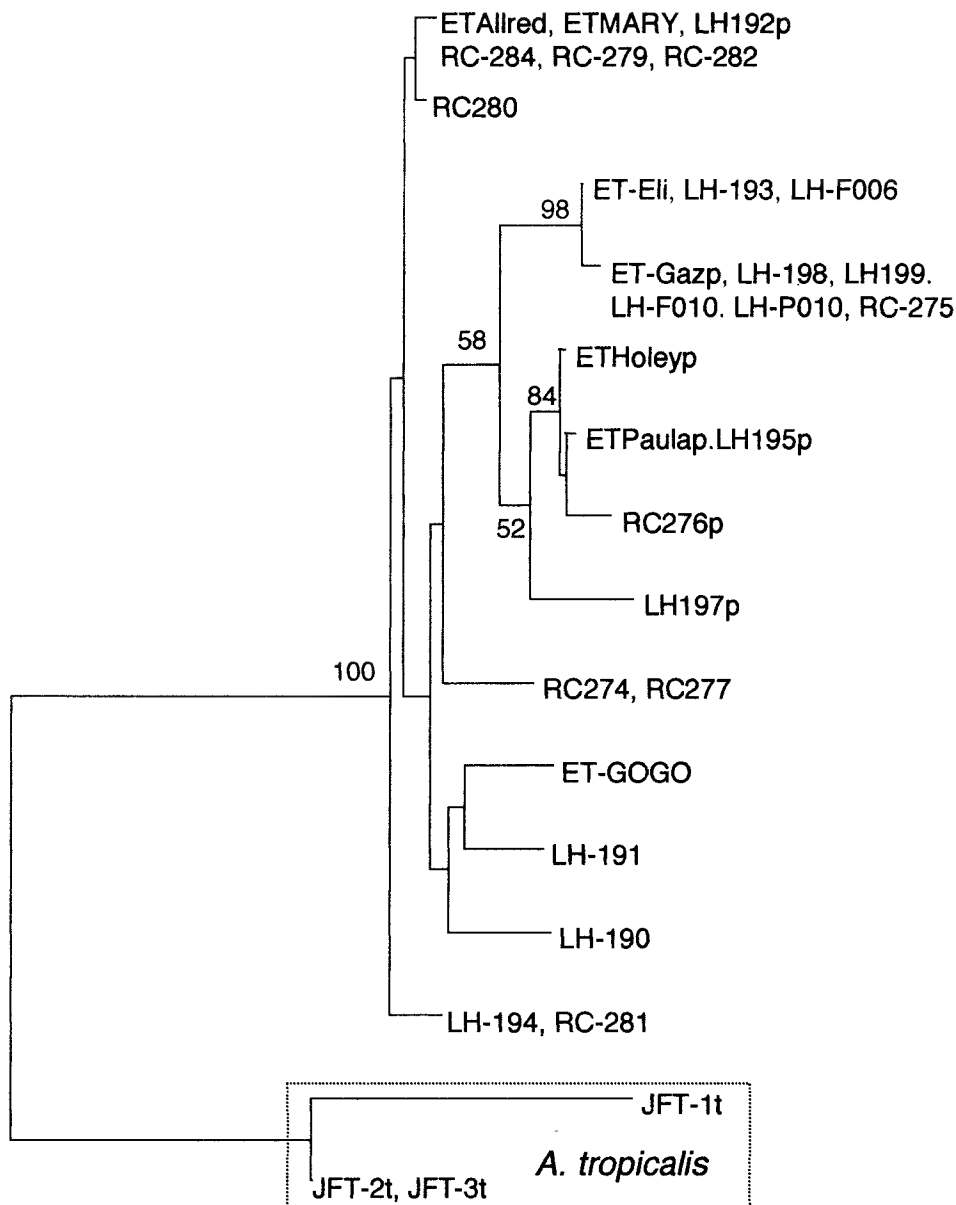

**Figure 4.** Minimum evolution tree of 15 haplotypes based on 307–315 bp of the mtDNA control region from 28 *A. philippii* and 3 *A. tropicalis* (JFT) from two sites on Alejandro Selkirk Island (Los Harenes, LH; El Tonga, ET) and one site on Robinson Crusoe Island (RC). Bootstrap support for nodes are also indicated.

population size at the time of rediscovery may be substantially biased. The original count of Bahamonde of 200 seals on Alejandro Selkirk Island in 1965 was only a partial count and may have underestimated the total population size by as much as 500 or more. Aguayo and Maturana (1970) counted 459 on all islands in the Juan Fernández Archipelago in 1969, but this census was conducted in March which is not the peak season. Further, they reportedly missed some caves, including one with 170 animals, as determined in a census conducted in February 1970, when 750 animals were counted (Aguayo et al. 1971). Finally, during censuses conducted by

John Francis between 1987 and 1992, many caves and beaches on Alejandro Selkirk Island were only accessible by boat and on the calmest days. Some of these sites were found to be so difficult to reach that they would have offered substantial refuge to the fur seals during the sealing era.

#### Genetic Structure

We also found that there is minor, but significant, genetic differentiation among populations on the two islands in the Juan Fernández Archipelago ( $F_{ST} = 0.082$ ,  $P = .05$ ), but no difference in variability between the two populations. The minor dif-

ferences in haplotype frequencies may have arisen stochastically via a recent founder event from Alejandro Selkirk to Robinson Crusoe Islands or subsequent drift. There are no clades in the phylogenetic trees that are limited to one island or another, so no evidence of any long-term divergence among the populations. Our results therefore cannot rule out the hypothesis that the species only survived at Alejandro Selkirk Island at the end of the sealing era.

Population differentiation is apparent in other seal populations where control region mtDNA have been investigated. In the Guadalupe fur seals, DNA samples obtained from 25 individuals from Isla de Guadalupe belonged to one of three major haplotype groups which could possibly represent some relict (presealing) population differentiation, as the species is currently restricted to a single breeding island (Bernardi et al. 1998). In Steller sea lions (*Eumetopias jubatus*), control region mtDNA sequences revealed high variability (52 haplotypes), with some haplotype lineages being specific to either an eastern (southeastern Alaska and Oregon) or western (Commander Islands to the Gulf of Alaska) population (Bickham et al. 1996).

#### References

- ABI, 1995. ABI PRISM<sup>®</sup> dye terminator cycle sequencing protocol. P/N 402078, Revision A.
- Anderson S, De Bruijn MHL, Coulson AR, Eperon IC, Sanger F, and Young IG, 1982. Complete sequence of bovine mitochondrial DNA. Conserved features of the mammalian mitochondrial genome. *Mol Biol* 156:683–717.
- Applied Biosystems, 1994. 373 DNA Sequencing System user's manual. Perkin-Elmer.
- Aguayo A and Maturana R, 1970. Primer censo de lobos finos en el archipelago de Juan Fernández. *Biol Pesq* 4: 3–15.
- Aguayo A, Maturana R, and Torres D, 1971. El lobo fino de Juan Fernández. *Rev Biol Mar* 14:135–149.
- Bahamonde N. 1966. El ma y sus recursos. In: *Geografía económica de Chile*, Primer apendice. Santiago, Chile: CORFO; 81–85.
- Begon M, Harper JL, and Townsend CR, 1986. *Ecology*. Oxford: Blackwell Scientific.
- Bernardi G, Fain SR, Gallo-Reynoso JP, Figueroa-Carranza AL, and LeBoeuf BJ, 1998. Genetic variability in Guadalupe fur seals. *J Hered* 89:301–305.
- Bester MN, 1987. Subantarctic fur seal, *Arctocephalus tropicalis*, at Gough Island (Tristan Da Cunha group). In: *Status, biology, and ecology of fur seals* (Croxall JP and Gentry RL, eds). NOAA Technical Report. NMFS 51: 57–60.
- Bickham JW, Patton JC, and Loughlin TR, 1996. High variability for control-region sequences in a marine mammal: implications for conservation and biogeography of Steller sea lions (*Eumetopias jubatus*). *J Mammal* 77:95–108.

- Boness DJ, 1991. Determinants of mating systems in the Otariidae (Pinnipedia). In: The behaviour of pinnipeds (Renouf D, ed). London: Chapman & Hall; 1–36.
- Bonnell M and Selander RK 1974. Elephant seals: genetic variation and near extinction. *Science* 184:908–909.
- Boyd IL, 1993. Pup production and distribution of breeding Antarctic fur seals (*Arctocephalus gazella*) at South Georgia. *Antarctic Sci* 5:17–24.
- Busch BC, 1985. The war against the seals. Montreal: McGill-Queen's University Press.
- Excoffier L, 1995. AMOVA 1.55 (analysis of molecular variance). Geneva, Switzerland: LGB, University of Geneva.
- Excoffier L, Smouse PE, and Quattro JM, 1992. Analysis of molecular variance inferred from metric distances among DNA haplotypes—application to human mitochondrial DNA restriction data. *Genetics* 131:479–491.
- Guinet C, Jouventin P, and Georges J-Y, 1994. Long term changes of fur seals *Arctocephalus gazella* and *Arctocephalus tropicalis* on subantarctic (Crozet) and subtropical (St. Paul and Amsterdam) islands and their possible relationship to El Nino southern oscillation. *Antarctic Sci* 6:473–478.
- Harpending HC, 1994. Signature of ancient population growth in a low-resolution mitochondrial DNA mismatch distribution. *Hum Biol* 66:591–600.
- Hoelzel AR and Green A, 1992. Analysis of population level variation by sequencing PCR-amplified DNA. In: Molecular genetic analysis of populations: a practical approach (Hoelzel AR, ed). Oxford: Oxford University Press; 159–187.
- Hoelzel AR, Halley J, O'Brien SJ, Campagna C, Arnborn T, Le Boeuf B, Ralls K, and Dover GA, 1993. Elephant seal genetic variation and the use of simulation models to investigate historical bottlenecks. *J Hered* 84:443–449.
- Holmeyer GJG, Bester MN, and Jonker FC, 1997. Changes in population sizes and distribution of fur seals at Marion Island. *Polar Biol* 17:50–158.
- Hubbs CL and Norris KS, 1971. Original teeming abundance, supposed extinction, and survival of the Juan Fernández fur seal. *Antarctic Res Ser* 18:35–52.
- Kretzmann MB, Gilmartin WG, Meyer A, Zegers GP, Fain SR, Taylor BF, and Costa DP, 1998. Low genetic variability in the Hawaiian monk seal. *Conserv Biol* 11:482–490.
- Kumar S, Tamura K, and Nei M, 1995. MEGA: molecular evolutionary genetics analysis, version 1.02. University Park, PA: Pennsylvania State University.
- Leberg PL, 1992. Effects of population bottlenecks on genetic diversity as measured by allozyme electrophoresis. *Evolution* 46:477–494.
- Maldonado JE, Davila FO, Stewart BS, Geefen E, and Wayne RK, 1995. Intraspecific genetic differentiation in California sea lions (*Zalophus californianus*) from southern California and the Gulf of California. *Mar Mammal Sci* 11:46–58.
- Maruyama T and Fuerst P, 1985. Population bottlenecks and nonequilibrium models in population genetics: II. Number of alleles in a small population that was formed by a recent bottleneck. *Genetics* 111:675–689.
- Nei M, 1987. Molecular evolutionary genetics. New York: Columbia University Press.
- Nei M, Maruyama T, and Chakraborty R, 1975. The bottleneck effect and genetic variability in populations. *Evolution* 29:1–10.
- Richards R, 1994. "The upland seal" of the Antipodes and Macquarie Islands: a historian's perspective. *J R Soc N Z* 24:289–295.
- Saitou N and Nei M, 1987. The neighbor-joining method: a new method for reconstructing phylogenetic trees. *Mol Biol Evol* 4:1406–1425.
- Schneider S, Roessli D, and Excoffier L, 1999. Arelquin, version 2.0b2: a software for population genetics data analysis. Geneva, Switzerland: University of Geneva.
- Shaughnessy PD and Goldsworthy SD, 1990. Population size and breeding season of the Antarctic fur seal *Arctocephalus gazella* at Heard Island—1987/88. *Mar Mammal Sci* 6:292–304.
- Slade RW, 1997. Genetic studies of the southern elephant seal *Mirounga leonina*. In: Marine mammal research in the Southern Hemisphere. Volume 1, Status, ecology and medicine (Hindell M and Kemper C, eds). Chipping Norton: Surrey Beatty and Sons; 11–29.
- Steel MA, Cooper AC, and Penny D, 1996. Confidence intervals for the divergence time of two clades. *Syst Biol* 45:127–134.
- Sullivan J, Holsinger KE, and Simon C, 1995. Among-site rate variation and phylogenetic analysis of 12S rRNA in sigmodontine rodents. *Mol Biol Evol* 12:988–1001.
- Swofford DL, 1997. PAUP\*, version 4.0d52-57. Sunderland, MA: Sinauer.
- Swofford DL, Olsen GJ, Waddell P, and Hillis DM, 1997. Methods of phylogenetic inference. In: Molecular systematics, 2nd ed (Hillis DM, Moritz C, and Mable BK, eds). Sunderland, MA: Sinauer; 407–514.
- Tajima F, 1989. Statistical method for testing the neutral mutation hypothesis of DNA polymorphism. *Genetics* 123:585–595.
- Tarr CL, Conant S, and Fleischer RC, 1998. Founder events and variation at microsatellite loci in an insular passerine bird, the Laysan finch (*Telespiza cantans*). *Mol Ecol* 7:719–731.
- Torres DN, 1987. Juan Fernández fur seal, *Arctocephalus philippii*. In: Status, biology, and ecology of fur seals (Croxall JP and Gentry RL, eds). NOAA Technical Report. NMFS 51:37–41.
- Wright S, 1931. Evolution in Mendelian populations. *Genetics* 16:97–159.
- Received March 25, 2000  
Accepted April 29, 2000  
Corresponding Editor: Stephen J. O'Brien