

cinerea, Cheetah *Acinonyx jubatus*, Przewalski's horse *Equus przewalskii*, Iranian onager *Equus hemionus onager*, Sitatunga *Tragelaphus spekei*, Nilgai *Boselaphus tragocamelus*, Ellipsen waterbuck *Kobus ellipsiprymnus*, Scimitar-horned oryx *Oryx dammah*.
Total = 15.

Reviews and interim recommendations made:

Luzon bleeding-heart pigeon *Gallicolumba luzonica*, Goodfellow's tree kangaroo *Dendrolagus goodfellowi shawmayeri*, Brush-tailed rock wallaby *Petrogale p. penicillata*, Emperor tamarin *Saguinus imperator subgriseus*, Chimpanzee *Pan troglodytes*, Fennec fox *Vulpes zerda*, Guanaco *Lama guanicoe*, Giraffe *Giraffa camelopardalis*, Eland *Taurotragus oryx*.
Total = 9.

Other international studbook species for which Species Co-ordinators have been appointed to prepare SMPs:

Brush-tailed bettong *Bettongia penicillata ogilbyi*, Black-and-white ruffed lemur *Varecia v. variegata*, Cotton-top tamarin *Saguinus o. oedipus*, Golden lion tamarin *Leontopithecus rosalia*, Red panda *Ailurus fulgens*, Snow leopard *Panthera uncia*, Southern white rhinoceros *Ceratotherium s. simum*.
Total = 7.

Manuscript submitted 18 April 1988

Population management: theory and practice

Int. Zoo Yb. (1988) 27: 26–41

© The Zoological Society of London

Management of small populations

THOMAS J. FOOSE¹ & JONATHAN D. BALLOU²

¹*AAZPA Conservation Co-ordinator, Minnesota Zoological Gardens, Apple Valley, Minnesota 55124 and* ²*Department of Zoological Research, National Zoological Park, Smithsonian Institution, Washington, DC 20008, USA*

It appears that the survival of many species, especially larger vertebrates, will depend upon assistance from captive propagation over the next century or more. Zoos and aquaria can and must serve as arks for vanishing wildlife.

However, captive propagation can truly assist conservation of endangered species only if zoo and aquarium populations are managed genetically and demographically in a manner to reinforce, not replace, wild populations. In the future, conservation strategies will ideally incorporate both captive and wild

populations that are interactively managed for mutual support, that is, through regulated interchange of animals or at least genetic and demographic material (e.g. through sperm or embryos). Captive populations can serve as reservoirs of genetic and demographic material that can be infused periodically into remnant wild populations or re-established in vacant wildlands if conditions were suitable. Reciprocally, the wild populations, even if only remnants, will still be subjected to natural selection and thus maintain some

semblance of the characteristic genetic makeup of the species in the wild.

Species are vanishing because a combination of habitat destruction and unsustainable exploitation are reducing and fragmenting wildlife populations. However, the situation is often worse than is indicated by simple numbers because of the particular characteristics of small populations, which are subject to stochastic or random problems that imperil their survival even if the other dangers can be eliminated (Gilpin & Soulé, 1986; Soulé, 1987). As a consequence, even when and where protection of remnant wild populations is feasible, it may not be sufficient to ensure the long-term survival of species. There are three general types of stochastic problems: environmental, demographic and genetic (Gilpin & Soulé, 1986).

Stochastic environmental problems are of several kinds: epidemic, disease, catastrophic events (natural disasters such as earthquakes or floods, fires, wars or, in the captive context, loss of financial or other support) (Dobson & May, 1986). For larger populations, such environmental disturbances may be localised and part of the population might survive (Shaffer, 1987). In general one of the advantages of captivity might be to moderate environmental stochasticity, for example drastic fluctuations in food supply should be less common in captivity than in the wild.

Demographically, stochastic problems afflicting small populations include unexpected failures in reproduction or survival, distortions of age distributions and biases in sex ratio. Severe random fluctuations in birth and death rates will be troublesome in very small populations. The failure of a few ♀♀ to reproduce as expected may have little effect on larger populations, but could be disastrous for a small population with only a few ♀♀. Age distributions will also be more vulnerable to stochastic destabilisation in small populations; extinction through senescence has occurred in a number of

captive groups. Another particular problem may be distortions in sex ratio; every zoo manager has been confronted with the phenomenon of a substantial number of consecutive births of predominantly one sex. In a small population such distorted sex ratios can be very disruptive.

Genetically, small populations tend to lose diversity rapidly through the stochastic process of genetic drift, as well as through inbreeding. Genetic diversity is important for both the adaptability of populations and the fitness (survival and fertility) of individuals. The smaller the population, the faster the loss (Appendix 1).

Reduction and fragmentation of small populations, be they captive or wild, convert gene pools into gene puddles that are vulnerable to evaporation in an ecological and evolutionary sense. Genetic and demographic analysis and management can be applied to counteract these problems. In general it may be easier to apply such measures in captivity but the same types of intensive management will increasingly be required in wild sanctuaries which in reality are becoming 'megazoos'.

Multi-institutional population propagation programmes for genetic and demographic management are being developed in several major regions: the Species Survival Plan (SSP) of the AAZPA in North America; the Europäisches Erhaltungszucht Programm (EEP) in Europe; the Joint Management of Species Programme of the British Zoo Federation and the Regional Studbook Programmes of the Anthropoid Ape Advisory Council in Great Britain; the Australasian Species Management Scheme in Australia and New Zealand; the SSP programmes in Japan. It is hoped that eventually these regional programmes can be integrated and co-ordinated internationally. The Captive Breeding Specialist Group of the IUCN Species Survival Commission, in co-operation with the International

Union of Directors of Zoological Gardens, would be appropriate bodies to co-ordinate such co-operation.

These SSP-type programmes will each be based upon a Masterplan for population management. Fundamentally a Masterplan provides *institution-by-institution and animal-by-animal recommendations* for the entire population encompassed by the programme. Individual recommendations should be orientated to well-defined goals and objectives and should reflect attempts at demographic and genetic management. Although the emphasis in this paper is on genetic and demographic management, other considerations such as basic husbandry, behavioural aspects and veterinary care will also be vital to viable captive management programmes. A basic protocol has been developed for this kind of population management in the AAZPA (SSP) programmes (Appendix 3).

Because genetic and demographic problems of small populations are a function of the population's size, a first step in developing a management programme for a captive population is to establish a captive carrying capacity. This will be the optimum number of individuals to be maintained over the long term and will represent a compromise between the minimum necessary for genetic and demographic viability and the maximum that can be accommodated without excluding other taxa from captive programmes.

The lower limit for carrying capacity is the Minimum Viable Population (MVP) size of the captive population. An MVP depends on two sets of factors: the demographic and genetic objectives of the programme and the biological characteristics of the population.

Demographic and genetic objectives include the probability of the population surviving; the kind and amount of genetic diversity to be preserved; the period of time over which this probability of

survival and level of diversity are to be sustained.

The perfect programme would ensure a 100% probability of survival and preservation of the total amount of all kinds of genetic diversity in the population for ever. In other words, it would protect against all the problems which confront small populations. Beyond the philosophical observation that nothing is certain or for ever, it is unrealistic to consider such a programme since the size of populations that can be maintained in captivity could never be large enough to achieve its objectives.

A general guideline recommended by some conservation biologists is that captive programmes should attempt to preserve 90% of the average heterozygosity of the founders for 200 years (Soulé *et al.*, 1986). Figure 1 illustrates several examples of minimum effective population sizes that would be necessary to preserve 90% average heterozygosity for 200 years.

Biological characteristics The fact that the MVP size depends on the generation time of the species as well as the number of effective founders leads to consideration of the second set of factors that determine the MVP, the biological characteristics of the population.

1. The generation time: the effect of generation time on the MVP size is based on the fact that genetic diversity is lost generation by generation not year by year. Thus for a given period of time, for example 200 years, a species with a shorter generation time will pass through more generations, have more opportunity to lose genetic diversity and hence require a larger MVP size than a species with a longer generation time.

2. The number of founders: the number of effective founders that establishes a captive population also determines the MVP (Fig. 1). An effective founder is a wild-caught animal that has reproduced to have descendants in the living, managed population. Living animals out

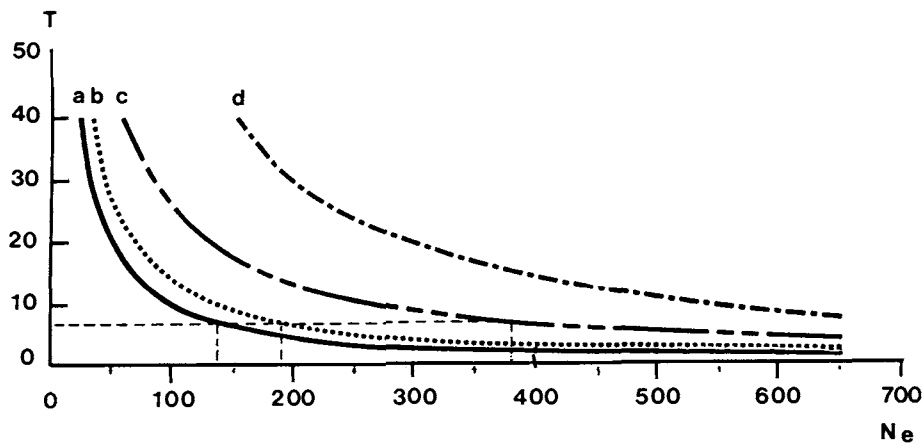

Fig. 1. Effective population sizes required to preserve 90% average heterozygosity for 200 years for populations with various generation times and effective founders. T, generation time; N_e , effective population size; a, no founder effect; b, 20 founders; c, eight founders; d, six founders.

of the wild that have not reproduced may be potential founders but they are not effective until they reproduce. Basically, the fewer the number of founders the larger must be the MVP. There is, however, a point of diminishing returns. For most species increasing the number of effective founders beyond 20–30 (to preserve average heterozygosity) or 30–50 (to preserve rare alleles from the wild population) will not significantly reduce the size of the MVP required for time periods in the order of 200 years (Allendorf, 1986). In most cases founders will not enter the population only at the start of the management programme; periodically, additional founders ('immigrants') will enter the population. As few as one effective wild-caught founder per generation can keep the captive population representative of a wild gene pool.

3. The N_e/N ratio: an MVP prescribes a population size required for some set of objectives. The population size of relevance, however, is not the simple census number (N), rather it is the genetically effective size, denoted by N_e . This is a measure of the way in which the population is reproducing to transmit its genes to the next generation. It is a

function of a number of variables: the number of animals that reproduce; the sex ratio of these animals; the mean and variance of their relative number of offspring (lifetime family sizes) (Lande & Barrowclough, 1987). In general the more disparate the sex ratio and family size, the lower N_e will be relative to N . In practical terms, N_e is usually only a fraction of N . Common ratios of N_e in genetically unmanaged populations are 0.2–0.5. As a consequence, actual carrying capacities may have to be several times larger than the N_e necessary to achieve the genetic objectives of the programme. For example, if an N_e of 250 were required for some set of objectives (e.g. maintaining 90% heterozygosity for 200 years), but the N_e ratio of the population was only 0.25, the carrying capacity that would have to be maintained would be 1000 individuals. By managing sex ratios and family sizes, N_e/N ratios can be improved and actual (carrying-capacity) MVPs reduced.

4. Growth rate: until a captive population attains its carrying capacity and while the population size remains small, genetic diversity will be lost at a relatively fast rate. The more rapidly the population can grow to carrying capacity the more it can

N_e and carrying capacity necessary for maintaining the specified amount of genetic diversity for a specified time period

YEARS PER GENERATION:	10	NO. GEN. DURING PERIOD:	20
YEARLY % GROWTH RATE:	1.080	GEN. GROWTH RATE:	2.16
EFFECTIVE NO. FOUNDERS:	25	GEN. EXPON. GROWTH	0.77
ESTIMATED N_e/N RATIO:	0.5		
DESIRED % HET. RETAINED:	0.90		
LENGTH OF TIME PERIOD:	200 YEARS		

Effective Size required to maintain desired amount of original variation for the specified length of time:	199
Carrying capacity necessary to maintain desired amount of the original variation over the time:	238

Table 1. An example of population viability analysis.

reduce the rate at which it loses genetic variation. Maximising the rate of growth will therefore minimise loss of diversity during the growth phase.

It must be emphasised that there is no single or magic number that represents an MVP for all species at any time or for any species all of the time (Soulé, 1987). The MVP size will vary with the circumstances of the programme. Computer software is available to perform the population viability analysis (PVA) that will prescribe MVPs required for various circumstances; some examples of such analysis are presented in Table 1.

A secondary consideration for determination of the MVP is demographic stochasticity which is significant if the MVP prescribed by genetic considerations is fewer than 50–100. Populations smaller than 50 and possibly even 100 may be particularly vulnerable to 'crashes' or extinctions due to random demographic causes such as epidemic diseases, natural disasters or sex ratio distortions (Shaffer, 1987; Soulé, 1987).

The MVP establishes the lower limit for the carrying capacity of a managed captive population. It should be evident from the preceding discussion that it is advantageous for a population to be larger than the MVP size; indeed, in this respect, more is always better. Enlarging any one captive population, however, might well exclude other taxa from the

zoo ark and therefore there has to be an upper limit on the carrying capacity for any one taxon in captivity.

The upper limit can be established by:

1. Assessing how much captive habitat (space and resources) is available for taxa with similar captive ecologies (i.e. forms that have equivalent enclosure requirements, resemble each other in terms of public expectation of what should be in a zoo, etc.). A crude measure of the captive habitat available is provided by the number of 'ecologically similar' specimens currently being maintained (Foose & Seal, 1986).
2. Ascertaining how many taxa with similar captive ecologies are in need of assistance by propagation in captivity. In this regard information from the IUCN SSC Specialist Groups will be important. The CBSG is already trying to develop recommendations for captive priorities among several broad groups, including psittacines and primates (Oates, 1985).
3. Allocating the captive habitat to as many taxa as possible while still maintaining an acceptable MVP for each.

Table 2 illustrates an attempt to apply this type of analysis to one group of animals, the large felids. As is the case for every broad category examined in this way so far, there is not enough captive habitat to accommodate acceptable MVPs for all the taxa that will need assistance to survive. This severe limitation of captive habitat argues

SPECIES	EXTANT SPP	SPP IN RDB	CAPTIVE POPULATION	NO. OF SPP IF POPULATION		
				100	250	500
<i>Panthera leo</i>	11	1	1079	10	4	2
<i>Panthera tigris</i>	8	8	1429	14	6	3
TOTAL lions, tigers	19	9	2508	25	10	5
<i>Panthera onca</i>	8	8	179	2		
<i>Panthera pardus</i>	15	15	503	5	2	1
<i>Panthera uncia</i>	1	1	312	3	1	
<i>Felis concolor</i>	29	2	280	3	1	
<i>Neofelis nebulosa</i>	4	4	202	2	1	
<i>Acinonyx jubatus</i>	6	6	454	4	2	1
TOTAL other large felids	63	36	1930	19	8	4
TOTAL	82	45	4438	44	18	9

Table 2. Capacity of captive facilities for the larger felids calculated from data in ISIS and the appropriate studbooks. (An example of analysis to determine capacity of zoos for taxa with similar captive ecologies.)

strongly for the participation of as much of the zoo world as possible in the population management programme and for international co-ordination of the regional efforts.

Once the carrying capacity is established the institution-by-institution and animal-by-animal recommendations must be formulated. Based on genetic and demographic guidelines or criteria for management, these recommendations form the basis of the SSP-type Masterplan. Appendices 1 and 2 describe the kinds of genetic and demographic analysis and models which are needed for population management. Generally the objectives will be to develop a genetically diverse and demographically stable population.

Genetic management objectives will normally be to: (1) adjust the representation of founder lineages to rectify past disparities, that is, there will be an attempt to adjust the existing founder distribution in the population to the target founder distribution that has been established for the population; (2) regulate family sizes and sex ratios to maximise effective size of the population. Until the disparities in founder representation are rectified the management programme will deliberately

reproduce from some animals more than from others. When these adjustments are completed, the objective will be for every animal to produce the same number of offspring. An exception to this guideline would be if there were a deliberate decision to have an unequal sex ratio for gregarious species when one family size objective will apply to ♀♀ and another to ♂♂. At carrying capacity each animal during its lifetime will be expected to produce on average two offspring, preferably one of each sex, which in turn survive to reproduce; (3) manage inbreeding coefficients to ensure that survival and fertility are not declining significantly.

Demography management objectives will normally be to: (1) expand the population from its founder or initial size to the carrying capacity as rapidly as possible within the constraints of the genetic guidelines, that is, regulation of family sizes and adjustment of founder representation. In cases of very small populations, demographic considerations will usually override genetic ones (Seal, in press); (2) stabilise the population at the carrying capacity by some combination of regulation of fertility (birth control) and survival (removal or culling). Programmes for regulation of fertility and

survival are based on analysis of life table data.

The institution-by-institution and animal-by-animal recommendations should specify which animals should reproduce when and with which mate to achieve the genetic and demographic objectives. These specifications will normally entail some relocation of animals between institutions to produce better genetic and demographic combinations of mates.

The Masterplan can then also determine what the genetic and demographic expectations are for each individual in the population. Once an individual has fulfilled what is expected or required of it in demographic and genetic terms, it becomes 'surplus' to the management programme. When this occurs, the individual should not reproduce again in or for the managed population.

Finally, it must be stated that genetic and demographic analysis are possible only if adequate data are available. Compilation of such data is the purpose of studbooks and the mission of ISIS and of the regional inventory systems around the world, all of which are thus vital to the conservation programmes of zoos.

APPENDIX 1

BASIC POPULATION GENETICS FOR CAPTIVE MANAGEMENT

Genetic diversity The many thousands of genes carried by an animal, interacting with the environment, ultimately control the structure and function of the organism. The site of a gene on a chromosome or elsewhere in the cell is known as its locus and the terms gene and locus tend to be used interchangeably. Almost all animals are diploid, carrying two copies of each gene which can occur in alternative forms or alleles. Different alleles may produce totally different effects in the organism. Where more than one allele exists there is genetic diversity. The genes of an individual are known as its genome. Collectively all the alleles for all the genes of all the individuals of a population or species constitute its gene pool.

Genetic diversity can occur at both the level of the individual and of the population (Fig. 2). If the two copies of a gene carried by an individual represent different alleles, the individual has genetic diversity and is known as heterozygous. If both copies are the same allele, there is no

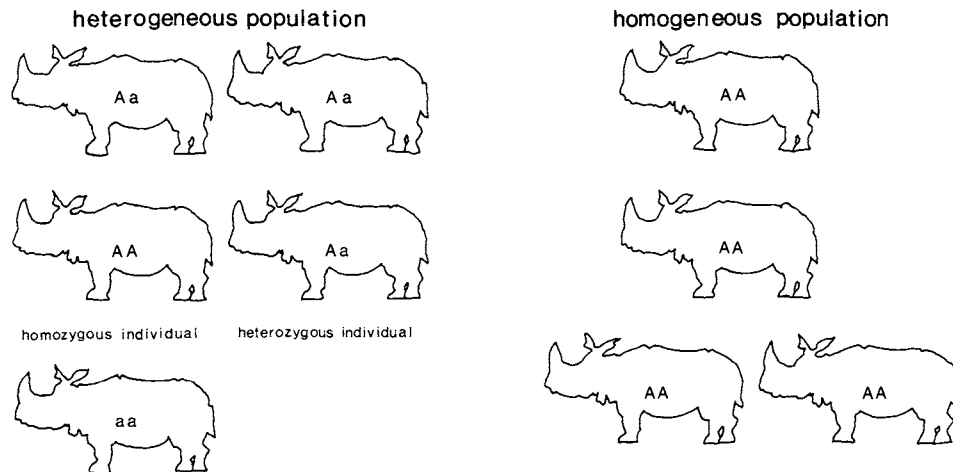

Fig. 2. Genetic diversity at both the individual and population level.

diversity and the individual is known as homozygous. Populations containing genetic diversity will have some heterozygous and some homozygous individuals. The terms heterogenous or polymorphic are sometimes used to describe a population with genetic diversity; homogenous is the analogous term for a population without diversity. At population level genetic diversity can be measured as allelic diversity or as average heterozygosity.

Genetic diversity is important for both individuals and populations. In populations it is needed in order to adapt to changing environments. For individuals heterozygosity is important for maintaining fitness, that is, the ability to survive and reproduce (Allendorf, 1986; Hedrick *et al.*, 1986).

The gene pools of a captive population can best be visualised through the genetic lineages or bloodlines that descend from the founder animals, that is, the animals from the wild that reproduce to have descendants in the living population. For captive populations, the original gene pool consists of all the genes that are

carried by the founders. Preserving genetic diversity is thus tantamount to preserving as many as possible of these founder genes in the population for as long as possible.

Genetic drift In small populations, alleles may be lost entirely from the gene pool through genetic drift, that is, the random or stochastic process which results when a limited and therefore incomplete sample of genes from one generation is selected for transmission to the next. In other words, reproduction constitutes a random draw of some of the alleles in the population for perpetuation in the offspring; alleles which are not passed on to any of the offspring are lost to genetic drift.

Founder representation An animal transmits a copy of only one of each pair of genes to its offspring which thus receives half of its genes from its sire and half from its dam. Thus by constructing an individual's pedigree back to its founders it is possible to determine what founder genes the living individual

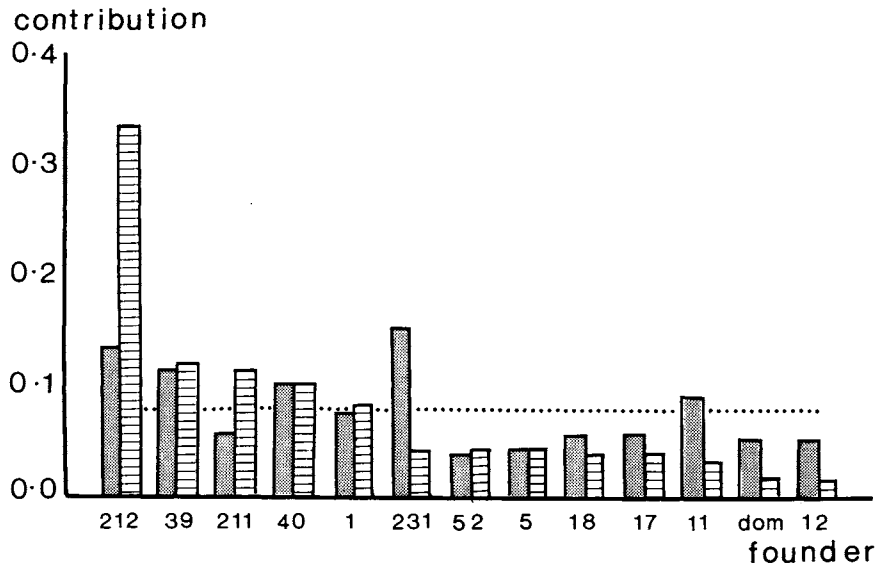

Fig. 3. Founder representation in the Przewalski horse *Equus przewalskii* SSP population at 1 March 1988. Cross-hatching = founder contribution; shading = target founder contribution; dotted line = parity.

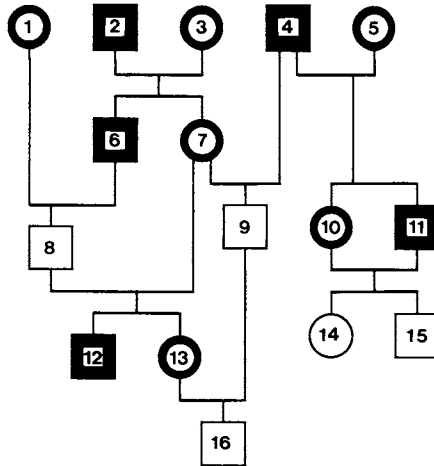

Fig. 4. An example of bottlenecks in a pedigree. Circles represent ♀♀, squares ♂♂; the black borders show deceased individuals; numbers 1-5 represent wild-bred founders; numbers 6-16 are their captive-bred descendants.

actually carries, that is, its founder representation. Summation of the founder representation over all founders provides the distribution of each founder genome in the population (Fig. 3). If the situation were this simple, maximising representation of genetic diversity over time would be a matter of equalising founder representation but the process is more complicated. Simple founder representation does not acknowledge that each founder actually carried two copies of each gene, that is, the founders are diploid not haploid. (For simplicity these two copies are referred to as two alleles in each founder even though they may not be different forms of the gene. Thus it is conventional to discuss founder alleles, not founder copies of genes.)

Because only one copy of each gene is transmitted from parent to offspring and because which of the two alleles carried by a parent is actually transmitted is a matter of chance, problems can be caused when a line of descent passes through very few individuals or perhaps even one animal. Such bottlenecks may prevent the perpetuation of one of the two founder alleles from that point onwards. As a

result only part of the genome of some founders may actually survive in the living population while all the alleles of other founders may still be present. In the extreme example of a bottleneck of one in the F_1 generation from a founder, at most only one allele from each locus, or 50% of the genome if all loci are considered, could actually be transmitted to future generations (Fig. 4).

Genetic management In order to maximise preservation of genetic diversity (i.e. maintain as many of the founder's alleles as possible), genetic management should attempt to develop representation of founder lineages that are proportional to the percentage of the founder genomes that still survive. Again, referring to the extreme example of a bottleneck of one, the ideal representation of this founder in the population should be half as much as for founders whose entire genomes survive.

It is possible from computer algorithms, such as gene drop programs, to estimate the probable loss of founder genes through pedigrees (MacCluer *et al.*, 1986). For any living population it is then possible to compute a distribution of the proportion of each founder's genome that survives. Based on this distribution, a target or desired distribution of founder representations can be calculated. Matings that will adjust the existing founder lineage representations towards the target distribution can then be recommended.

Loss of alleles will obviously reduce the diversity of the population as a whole. Once the alleles have disappeared they can be recovered only through the very slow process of mutation or through migration from another population (if there is one). Attempts to prevent the loss of alleles from the population therefore have priority in genetic management.

The way in which alleles are arranged in individuals is also important. In small populations, animals are more likely to breed with relatives resulting in increased

levels of inbreeding. Inbred organisms have higher levels of homozygosity since there is a greater probability that an identical copy of an allele at any one locus will be received from its sire and dam. These alleles are said to be identical by descent. Thus the alleles that do remain in the population tend to become organised into more homozygous than heterozygous individuals. Since increased levels of homozygosity can expose potentially deleterious recessive alleles, the result can be so-called inbreeding depression, that is, a reduction in the animal's ability to survive and reproduce compared with that of the non-inbred animal. Inbreeding depression has been demonstrated in many captive populations (Ralls & Ballou, 1983) and management must therefore consider inbreeding levels in captive populations. Preventing loss of alleles and avoiding inbreeding are not always equivalent; they may even be in conflict. In most such cases the prevention of loss of alleles will have the higher priority unless inbreeding depression is severe enough to endanger the continued survival of the population (Templeton & Read, 1984).

Recommended reading on genetic management and conservation biology includes Soulé & Wilcox, 1980; Frankel & Soulé, 1981; Foose, 1983; Allendorf & Leary, 1986; Ralls & Ballou, 1986.

APPENDIX 2

BASIC DEMOGRAPHY FOR CAPTIVE MANAGEMENT

Population management requires the integration of both genetic and demographic analyses. For example, generation length, which is calculated from survival and fecundity rates, is essential for estimates of MVP size requirements while age distribution, sex ratios and reproductive rates are used to calculate effective population sizes.

This Appendix is essentially a basic demographic primer covering some of the fundamental concepts necessary for

conducting demographic analyses of captive populations. Of primary importance are life tables, generation length, population growth rates and stable age distributions.

LIFE TABLES

Life tables contain information on age-specific survival and fecundity rates in the population. Usually these rates are calculated separately for each sex. Age classes are typically represented as yearly intervals. For each age class, the following demographic parameters are calculated:

Mortality rate (q_x) is the proportion of individuals that die during age class x . It is calculated from the number of animals that die during an age class divided by the number of animals that were alive at the beginning of the age class (i.e. the number of animals 'at risk' during the age class) (Table 3). Individuals still alive in the age class are not included in the q_x calculation because they have not yet lived through the entire age class.

Age-specific survival rate (p_x) is the proportion of individuals surviving from the beginning of the age class (x) to the beginning of the next age class ($x+1$). It is simply $1 - q_x$ (Table 3).

Age-specific survivorship (l_x) is the proportion of individuals surviving from birth to the beginning of the age class. The l_x for the first age class (denoted age class 0 because it includes animals aged 0-1 years) is 1.00; 100% of the individuals survive to the beginning of age class 0. The l_x values are most simply calculated from the p_x values and are the product of all p_x values from age class 0 up to, but not including, the age class for which the l_x is being calculated (Table 3).

Fecundity rate (m_x) is the average number of same-sexed young born to (or sired by) animals in that age class. For example, in a life table for ♀♀ the m_x

CLASS	NO. OF ♀♀	NO. OF DEATHS	NO. OF ♀ BIRTHS	MORTALITY RATE q_x	AGE-SPECIFIC	AGE-SPECIFIC	FECUNDITY	
					SURVIVAL RATE p_x	SURVIVORSHIP RATE l_x	RATE m_x	$l_x m_x$
0-1	100	40	0	0.4	0.6	1.0	0	0
1-2	60	10	36	0.17	0.83	0.6	0.6	0.36
2-3	50	30	75	0.6	0.4	0.5	1.5	0.75
3-4	20	20	10	1.0	0	0.2	0.5	0.1
4-5	0	0	0			0	0	0

Net Reproductive Rate (R_0) = 1.21

Table 3. Calculation of ♀ life-table data from information on ♀ births and deaths in a hypothetical population.

would refer to the average number of ♀ offspring born to ♀♀ in age class x . The m_x values are calculated by dividing the number of ♀ (or ♂) births by the number of ♀♀ (or ♂♂) alive at the beginning of an age class (Table 3). The fecundity rates provide information on the age of first and last reproduction, and ages of maximum reproduction.

Table 3 shows a simple life table for a population consisting of five age classes, aged 0-5. Values of q_x , p_x , l_x and m_x are calculated for each age class from data on numbers of deaths and births in a hypothetical population. Values of l_x and m_x can be plotted to illustrate graphically the survivorship and reproductive rates in the population (Figs 5 and 6).

These data are used to calculate values of generation time, population growth rate and stable age structure for the population.



Fig. 5. Age-specific survivorship, l_x .

GENERATION LENGTH

Conceptually, the generation length is the age at which an individual 'replaces' itself in the population. Technically, it is defined as the average age at which a ♀ (or ♂) produces offspring (Caughley, 1977). If data were available on the age of each parent when it produced young, the average of these ages would be the generation length of the population. Generation length is often incorrectly thought of as the age of first reproduction; however, this underestimates generation lengths in most cases. Males and ♀♀ often have different generation lengths.

The generation length can also be calculated direct from the l_x and m_x life table data. The l_x values provide the proportion of animals surviving to each age class while the m_x values provide how many young these survivors produce. The product of $l_x m_x$ is therefore the

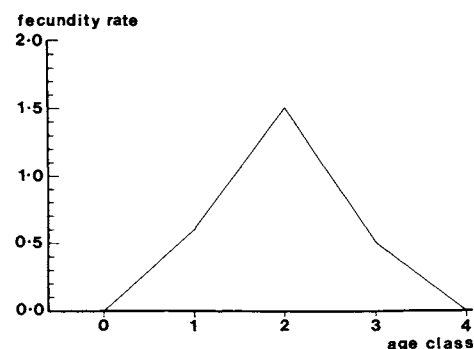

Fig. 6. Age-specific fecundity, m_x .

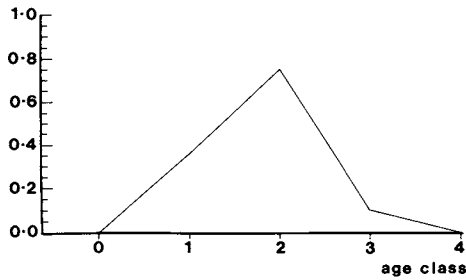

Fig. 7. The product of $l_x m_x$.

contribution of age class x to total reproduction. Figure 7 shows the distribution of $l_x m_x$ values for the hypothetical population in Table 3. The generation length is the mean age of this distribution and is calculated by:

$$\text{Generation Length (T)} = \frac{\sum x l_x m_x}{\sum l_x m_x}$$

Therefore, the generation length is the weighted average of reproductive age classes where the weights are the $l_x m_x$ values.

$$\text{For the example: } T = \frac{2.16}{1.21} = 1.79$$

which corresponds with the apparent average in Fig. 6.

POPULATION GROWTH RATES

The life table data provide accurate estimates of the future growth rate of the population only if survival and reproductive rates remain constant over time. Since population growth rates are a function of birth and survival rates, the reproductive values again provide the basic data needed to calculate growth rates.

If a generation of ♀♀ (or ♂♂) lived out their lifetimes according to the survival and fecundity rates shown in the life table, how many ♀ (or ♂) offspring would they leave to replace themselves? In other words, how would the population size change from one generation to the next? The sum of $l_x m_x$ values over all ages is the average number of ♀ (or ♂) offspring

surviving to replace each individual and therefore provides an estimate of the population's growth rate per generation. The sum of $l_x m_x$ values in the example is 1.21 (Table 3). Therefore, on the average, each ♀ leaves 1.21 ♀ young in the next generation and the population grows at 21% per generation. This sum is called the net reproductive rate (R_0).

If each ♀ were only to replace herself each generation, the net reproductive rate would be 1.00 and the population would remain the same size. The R_0 in growing populations is greater than one; declining populations have an R_0 of less than one.

A more useful measure is the growth rate per year (λ). This is calculated direct from the growth rate per generation:

$$\lambda = R_0^{(1/T)}$$

For the example, with R_0 at 1.21 and T at 1.8, the yearly growth rate is :

$$\lambda = 1.21^{(1/1.8)} = 1.11, \text{ or } 11\% \text{ per year.}$$

Another commonly used measure of yearly growth rate is the intrinsic rate of increase, or r . It is the exponential yearly growth rate of the population and is related to λ in the following way:

$$r = \log_e(\lambda).$$

For the example:

$$r = \log_e(1.11) = 0.10.$$

STABLE AGE DISTRIBUTION

If survival and reproductive rates remain constant over time, the proportion of animals in each age class will become constant from one year to the next and the population will achieve a Stable Age Distribution (SAD); the population is stable. The SAD is also determined entirely from the survival and fecundity rates and each unique combination of rates will result in a unique SAD. In a stable population, the proportion of the population in age class x is:

$$C_x = \frac{\lambda^{-x} l_x}{\sum \lambda^{-i} l_i}$$

AGE CLASS	$\lambda^{-1}l_x$	C_x
0-1	1.0	48%
1-2	0.54	26%
2-3	0.41	20%
3-4	0.15	7%
4-5	0	0%
Total =	2.1	101%

Table 4. ♀ stable age distribution (C_x) calculated from life table values shown in Table 3 and a yearly growth rate of 11%.

SAD for the example is shown in Table 4. Since survival and reproductive rates can differ between sexes, so can their SAD.

OTHER APPLICATIONS AND POPULATION MANAGEMENT

Several other demographic parameters can be calculated from life-table data. One demographic question of particular interest to population management is how to manage reproductive and survival rates to achieve zero population growth (i.e. $\lambda = 1.00$) for a population at carrying capacity.

One simple option is to examine the effect of delaying age of first reproduction to a later age class. In the example, if age of first reproduction were delayed to age class 2, the R_0 would be reduced to 0.85 (the sum of the $l_x m_x$ values for ages 2, 3 and 4). This would reduce the generation growth rate to below self-sustainment; the population would be reduced by 15% per generation; the generation length would be extended to 2.1 years and the per year growth rate would be 0.92 (8% reduction per year). Clearly this is too much of a reduction in reproduction. However, if the age of first reproduction were delayed for only 50% of the individuals, the m_x value in the example for age class 1 would be 0.3, the R_0 reduced to 1.03, the generation length increased to 1.9 years, and the yearly growth rate reduced to 1.02 (a 2% increase per year). This is obviously a more appropriate alternative than delaying age of first reproduction for all individuals.

Similar types of manipulation are possible for estimating survival rates necessary for zero population growth. Rather than guess what levels of reproduction or survival rates will achieve λ of 1.00, however, methods for calculating exact m_x and l_x values are available (Goodman 1980).

These basic demographic concepts summarise some of the primary calculations used for demographic management. When analysing real populations, however, modifications of basic methods are often necessary. For example, calculations of generation length need to be modified for populations with largely overlapping generations and life tables might be calculated differently for seasonal versus aseasonal breeders (Caughley, 1977). Several computer programs are currently available for calculating and modeling demographic data for captive populations (Ballou & Bingaman, 1986; Bingaman & Ballou, 1986; Rockwell & Teare, 1986; Flesness & Scobie, 1987). Most of these require studbook data in pre-specified format (ISIS ARKS format or Omaha Studbook format). Methods for statistical analyses of life-table data are included and discussed in Lee (1980).

Further useful references include: Caughley, 1977; Keyfitz, 1968; Goodman, 1980; Mertz, 1970; Beddington & Taylor, 1973; Foose, 1983.

APPENDIX 3

THE AAZPA SSP PROTOCOL FOR DEVELOPMENT OF A POPULATION MANAGEMENT MASTERPLAN

DATA COMPILATION

The first step in the development of an SSP Masterplan is to compile the basic data required for population analysis. This compilation will often be in the form of a studbook. However, ISIS should be involved in the compilation process: initially as a source of some of the data for studbook development; ultimately as

a repository of the assembled data. An important part of the compilation process is a 'clean up' of the ISIS data.

The basic data required on each animal for population analysis and management are: (a) individual identification (a simple numeric lifetime identity); (b) sex; (c) birth date; (d) death date; (e) parentage (if captive born); (f) place of capture (if wild caught); (g) institutions/facilities where it has been held, with dates; (To achieve this identification, it may be necessary to link a series of different ID numbers the animal has had as it moved from one institution to another in its captive history, e.g. the local ISIS specimen ID numbers.) (h) available information on circumstances of death.

With these data, genetic and demographic analyses can be performed.

GENETIC ANALYSES

(a) construct the pedigree for each animal in the population; (This process may be the construction of a pedigree chart; more often it will be an inherent part of various algorithms and computer programs, e.g. the additive relationship matrix or various 'gene drop' computations.) (b) identify all the founders of the population; (A founder is an animal which is from outside the population, usually the wild, and which has no known relationship to any other individual at its time of entry into the population and has descendants in the living population.) (c) compute the representation of founders ('bloodlines'), or preferably the probable distribution of founder alleles, in living individuals and the present population as a whole; (d) locate any extreme bottlenecks in the history of particular founder lineages or bloodlines and compute the proportion of each founder's genome that has survived to the living population (see Appendix 1); (This step may be an inherent part of more sophisticated algorithms that calculate probable distributions of founder alleles rather than just crude founder representation.) (e) calculate the founder

representation or founder allele distribution in offspring of the possible matings of living members of the population; (f) determine the number and sex ratio of animals that actually reproduce in the population; (g) calculate the number of offspring of each living individual in the population and hence the mean and variance of lifetime family sizes; (h) estimate the genetically effective population size (N_e) of the population and then the N_e/N ratio, where N is the total number of animals in the population; (i) calculate the inbreeding coefficients of existing individuals in the population and of the potential offspring of possible matings between these animals; (j) conduct various biochemical analyses as needed that measure genetic variability, genetic distance and identity (e.g. electrophoretic, DNA and karyotypic studies).

DEMOGRAPHIC ANALYSES

(a) determine the size of the current population and the number of institutions over which it is distributed; (Usually it will also be necessary to obtain the same kind of information for other taxa with similar 'captive ecologies', that is, space and resource requirements, but in less detail, for example the Siberian tiger SSP needs to be cognisant of the other tiger and large felid populations.) (b) determine the age and sex structure of the population; (c) compute the age-specific survivorships and fertilities of the population, that is, construct a life table (see Appendix 2); (d) establish a carrying capacity that is a compromise between a minimum viable population (MVP) for genetic and demographic viability and a maximum number that will not preclude other taxa from the zoo ark; (This carrying capacity should be based on the programme's goals as well as the biological characteristics of the population and should specify the number not only of animals but of the facilities over which they should best be distributed. In the absence of more

refined or species-specific recommendations on the long-term genetic objectives, the guideline of maintaining 90% of the founders' heterozygosity for 200 years may be used as a crude starting point.) (e) using the survival and reproductive rates from (c), calculate: the rate of change, that is, the growth or decline, of the population; the capacity of the population for self-sustainment; whether the population is at, or when it will be at, the carrying capacity; how the fertilities and survivorships can be managed by 'removals' of animals and regulation of reproduction (birth control) to stabilise the population at the desired carrying capacity; (This process may entail much 'what if..?' analysis to determine how management's modifications to the patterns of survivorship and fertilities will affect population size, growth rate, age distribution, etc.) (f) if survivorships and fertilities are not adequate for the population to be self-sustaining, devise appropriate research and husbandry programmes to resolve the problems.

POPULATION MANAGEMENT

Once genetic and demographic analyses are performed, an SSP Masterplan for propagation and management of the population can be formulated. The SSP Masterplan should provide institution-by-institution and animal-by-animal recommendations for every individual in the population maintained by SSP participants. Specifically, the Masterplan should: (a) designate which animals are surplus because they are: from over-represented bloodlines or lineages, too old to reproduce, have already produced their share of offspring and have attained the oldest age class necessary or allowable for a stable age distribution in the SSP population; (b) state explicitly that surplus animals should not be allowed to reproduce again; (Further recommendations on disposal of surplus will vary from programme to programme, time to time and institution to institution. In this

connection the issue of euthanasia will have to be confronted.) (c) recommend which animals should reproduce, when (a schedule over at least the next one to five years is needed) and with which mate (identify specific individuals and any recommended shipments of animals); (d) explain the genetic and demographic analyses and objectives on which the surplus and reproduction recommendations are based; (There should also be an explanation of how the Masterplan arrived at the particular carrying capacity established.)

Normally, these genetic and demographic guidelines will include: an attempt to expand rapidly and stabilise the population at its established carrying capacity and a strategy to maximise preservation of genetic diversity. Currently, the best methods to achieve these objectives seem to be to: (1) adjust representation of founder lineages to be proportional to the probable distribution of alleles surviving from founders at the initiation of the programme; (2) equalise lifetime family sizes; (This process will become fully operative only when the past inequalities in founder representation have been corrected.) (3) manage inbreeding coefficients; (4) perhaps subdivide the population into several parts or demes between which gene flow (i.e. usually exchange of animals but also increasingly of gametes or embryos) is regulated.

HUSBANDRY STANDARDS

Husbandry standards for the taxon should be developed, culminating in a *Handbook* which can be kept current as new advances occur.

REVIEW AND RATIFICATION

Once the SSP Masterplan is formulated, it should be reviewed, revised if appropriate and ratified by the AAZPA Propagation Group. The Masterplan should then be submitted to the SSP Subcommittee for their evaluation, recommendations and endorsement.

IMPLEMENTATION

Once approved, the Masterplan should be distributed to each of the participating institutions through its institutional representatives. The Species Coordinators and Propagation Group should provide follow-up to encourage and facilitate implementation.

REFERENCES

- ALLENDORF, F. (1986): Genetic drift and the loss of alleles versus heterozygosity. *Zoo Biol.* **5**: 181-190.
- ALLENDORF, F. W. & LEARY, R. F. (1986): Heterozygosity and fitness in natural populations of animals. In *Conservation biology: the science of scarcity and diversity*: 57-76 Soulé, M. E. (Ed.). Sunderland, MA: Sinauer Associates.
- BALLOU, J. D. & BINGAMAN, L. (1986): *PEDEMO: dBase III life-table generator*. Washington, DC: National Zoological Park.
- BEDDINGTON, J. R. & TAYLOR, D. B. (1973): Optimum age specific harvesting of a population. *Biometrics* **29**: 801-809.
- BINGAMAN, L. & BALLOU, J. D. (1986): *DEMOGRAPHY: Lotus 1-2-3 spreadsheet demographic model*. Washington, D.C.: National Zoological Park.
- CAUGHLEY, G. (1977): *Analysis of vertebrate populations*. New York: John Wiley & Sons.
- DOBSON, A. P. & MAY, R. M. (1986): Disease and conservation. In *Conservation biology: the science of scarcity and diversity*. 345-365. Soulé, M. E. (Ed.). Sunderland, MA: Sinauer Associates.
- FLESNESS, N. R. & SCOBIE, P. N. (1987): *User manual for ARKS Animal Records Keeping System*. Apple Valley, MN: International Species Inventory System (ISIS).
- FOOSE, T. J. (1983): The relevance of captive propagation to the conservation of biotic diversity. In *Genetics and conservation*: 374-401. Schonewald-Cox, C. M., Chambers, S. M., MacBryde, B. & Thomas, L. (Eds). Menlo Park, CA: Benjamin/Cummings.
- FOOSE, T. J. & SEAL, U. S. (1986): Species Survival Plans for large cats in North American zoos. In *Cats of the world*: 173-198. Miller, S. D. & Everett, D. D. (Eds). Washington, DC: National Wildlife Federation.
- FRANKEL, O. H. & SOULÉ, M. E. (1981): *Conservation and evolution*. Cambridge: Cambridge University Press.
- GILPIN, M. E. & SOULÉ, M. E. (1986): Minimum viable populations: processes of species extinction. In *Conservation biology: the science of scarcity and diversity*: 19-34. Soulé, M. E. (Ed.). Sunderland, MA: Sinauer Associates.
- GOODMAN, D. (1980): Demographic intervention for closely managed populations. In *Conservation biology*: 171-195. Soulé, M. E. & Wilcox, B. A. (Eds). Sunderland, MA: Sinauer Associates.
- HEDRICK, P. W., BRUSSARD, P. F., ALLENDORF, F. W., BEARDMORE, J. A. & ORZACK, S. (1986): Protein variation, fitness and captive propagation. *Zoo Biol.* **5**: 91-99.
- KEYFITZ, N. (1968): *Introduction to the mathematics of populations*. Reading, MA: Addison-Wesley.
- LANDE, R. & BARROWCLOUGH, G. (1987): Effective population size, genetic variation, and their use in population management. In *Viable populations for conservation*: 87-124. Soulé, M. E. (Ed.). Cambridge: Cambridge University Press.
- LEE, E. T. (1980): *Statistical methods for survival data analysis*. Belmont, CA: Lifetime Learning Publications.
- MACCLUER, J. W., VANDEBERG, J. L., READ, B. & RYDER, O. A. (1986): Pedigree analysis by computer simulation. *Zoo Biol.* **5**: 147-160.
- MERTZ, D. B. (1970): Notes on methods used in life-history studies. In *Ecology and ecological genetics*: 4-17. Connell, J. H., Mertz, D. B. & Murdoch, W. W. (Eds). New York: Harper & Row.
- OATES, J. F. (1985): *Action plan for African primate conservation: 1986-1990*. Washington, DC: WWF Primate Program and IUCN/SSC Primate Specialist Group.
- RALLS, K. & BALLOU, J. D. (1983): Extinction: lessons from zoos. In *Genetics and conservation*: 164-184. Schonewald-Cox, C. M., Chambers, S. M., MacBryde, B. & Thomas, L. (Eds). Menlo Park, CA: Benjamin/Cummings.
- RALLS, K. & BALLOU, J. D. (1986): Preface to the proceedings of the workshop on genetic management of captive populations. *Zoo Biol.* **5**: 81-86.
- ROCKWELL, R. & TEARE, A. (1986): *Studbook management system*. Omaha, NE: Henry Doorly Zoo.
- SEAL, U. S. (In press). *Proceedings of workshop on reproductive biology of black-footed ferrets and small population biology as they relate to conservation*. New Haven, CN: Yale University Press.
- SHAFFER, M. (1987): Minimum viable populations: coping with uncertainty. In *Viable populations for conservation*: 69-86. Soulé, M. E. (Ed.). Cambridge: Cambridge University Press.
- SOULÉ, M. E. (Ed.) (1987): *Viable populations for conservation*. Cambridge: Cambridge University Press.
- SOULÉ, M., GILPIN, M., CONWAY, W. & FOOSE, T. (1986): The millenium ark: how long a voyage, how many staterooms, how many passengers? *Zoo Biol.* **5**: 101-113.
- SOULÉ, M. E. & WILCOX, B. A. (1980): *Conservation biology*. Sunderland, MA: Sinauer Associates.
- TEMPLETON, A. R. & READ, B. (1984): Factors eliminating inbreeding depression in a captive herd of Speke's gazelle. *Zoo Biol.* **3**: 177-199.

Manuscript submitted 15 April 1988