



Maney Publishing

Aluminum Honeycomb Supports: Their Fabrication and Use in Painting Conservation

Author(s): Marion F. Mecklenburg and Judith E. Webster

Source: *Studies in Conservation*, Vol. 22, No. 4 (Nov., 1977), pp. 177-189

Published by: [Maney Publishing](#) on behalf of the [International Institute for Conservation of Historic and Artistic Works](#)

Stable URL: <http://www.jstor.org/stable/1505834>

Accessed: 05/12/2014 11:11

Your use of the JSTOR archive indicates your acceptance of the Terms & Conditions of Use, available at <http://www.jstor.org/page/info/about/policies/terms.jsp>

JSTOR is a not-for-profit service that helps scholars, researchers, and students discover, use, and build upon a wide range of content in a trusted digital archive. We use information technology and tools to increase productivity and facilitate new forms of scholarship. For more information about JSTOR, please contact support@jstor.org.



Maney Publishing and International Institute for Conservation of Historic and Artistic Works are collaborating with JSTOR to digitize, preserve and extend access to *Studies in Conservation*.

<http://www.jstor.org>

ALUMINUM HONEYCOMB SUPPORTS: THEIR FABRICATION AND USE IN PAINTING CONSERVATION

MARION F. MECKLENBURG and JUDITH E. WEBSTER

Abstract—The fabrication and use of aluminum honeycomb core solid support panels for paintings on fabric are described, using standard materials and laboratory equipment. Techniques of mounting paintings to such all-aluminum solid supports employing the vacuum hot table and both wax/resin and thermoplastic adhesives are discussed. Alternative methods of panel fabrication and technical information on current materials are noted.

I. INTRODUCTION

For some time it has been apparent that the traditional method of consolidation, or lining, of a painting on fabric by bonding it to an auxiliary fabric support does not provide a satisfactory result in every case. It has been observed that torn paintings with marked distortion at the periphery of the damage, when lined on fabric, have an unfortunate tendency to revert to the original distortion, forcing the new fabric support out of plane and into conformation. In the case of oversize paintings, the combined weight of the original tensioned fabric, ground and design layers is an inherent weakness leading to eventual bond failure and cleavage of the ground and paint layers. The presumption is that this is due to compression when humidity oscillations have deprived the fabric support of its ability to maintain the structure in plane. The traditional lining, employing additional fabric and adhesive, adds to the weight and compounds the problem.

In addition to problems presented by physical deterioration, of increasing concern to conservators are problems arising from the transportation and exhibition of paintings. Mr George Stout has discussed these problems specifically in regard to vandalism, rapid vibration or oscillation of fabric supports during shipping, and environmental changes in humidity and temperature during such moves [1].

Many painting conservators today believe that a solid support provides a reasonable solution to these specific consolidation problems. Two recent papers have described the construction of rigid panels of end-grain balsa wood core and birch veneer plywood skins as supports for paintings with severe distortion [2, 3].

As early as 1957, Stefan Slabczynski, then Chief Restorer at the Tate Gallery, London, built a panel with a kraft paper honeycomb core and masonite skins as a support for a painting by William Blake with severe cleavage problems. Honeycomb panels of this type are currently manufactured by Lebrun of New York. In 1971 Alexander Dunluce, Mr Slabczynski's successor, mounted a large painting by R. Delaunay on a honeycomb panel using paper core with fiberglas sheet and PVA as an adhesive. Subsequently he marouflaged a painting by Picasso to a panel constructed of paper core, 2 mm fiberglas sheets with a wax/resin adhesive and mulberry tissue interleave. Experimentation with solid support systems is continuing [4, 5]. This early use of honeycomb panels constructed at the Tate was influential to our undertaking similar experiments.

If, then, a solid support can provide a solution to specific problems encountered in consolidation, what performance standards should be required? Certainly, the following:

- 1 – Long term durability and stability. A panel must remain stable in most environments

2*

and be chemically inert.

- 2 – Sufficient rigidity to perform the task required.
- 3 – Resistance to surface deformation.
- 4 – Ease of construction, including the potential for the fabrication of large panels.
- 5 – Light weight.
- 6 – Ease in use. A panel must be compatible with currently accepted adhesives and lining procedures, and meet requirements for reversibility.

It is the choice of *materials* which ultimately governs panel behavior in a given environment. There are many possible structural combinations. Major differences occur in the materials used for fabrication, as is evidenced by the papers presented over the last few years describing various methods.

A painting's environment, including such factors as relative humidity, temperature, and airborne contaminants, is a primary concern in the preservation of paintings. Airborne contaminants can be filtered and relatively stable temperatures can be achieved. Relative humidity, however, is difficult to stabilize. A material impervious to moisture variation, yet stable enough through a controlled range of temperature variation, is essential.

Aluminum fulfills these requirements and, unlike natural materials, has known uniform physical properties which permit the analytic determination of structures. An all-aluminum structure has performance characteristics that can be predicted.

In the spring of 1974 the Washington Conservation Studio undertook the restoration of a major painting owned by the US National Park Service. The painting, *The Grand Canyon of the Yellowstone* by Thomas Moran, measures 144 × 84 in. Upon examination, it was evident that there was extensive compression cleavage due to the relatively thick ground and design layers, the failure of the upper tacking edge of the support fabric, and the considerable weight of the combined fabric and design layer. The pattern of this compression cleavage has since been observed with some frequency on other very large oil paintings on canvas. If the painting were to be consolidated and relined using conventional adhesives and new fabric support, only a temporary stay of deterioration would be achieved. The tension required to maintain a painting of this scale in plane would be enormous, requiring great fabric strength and heavy stretcher construction. The added weight would inevitably lead to the eventual repetition of the failure. If, however, a solid support were used, no tension to either the support fabric, ground, or design layer would be required. The bonding adhesive need only be adequate to hold the painting in contact with the panel surface while the panel would provide all necessary structural integrity and in-plane continuity.

A bonded aluminum honeycomb core panel offered a possible solution. In consultation with Mr Ned Miller of the Hexcel Corporation, structural performance requirements were defined and the fabricated results were as follows:*

- 1 – Dimensions 144 × 84 in., with deflection under panel weight no more than 2 in. out of plane in long direction.
- 2 – 15 mil skins 5052 aluminum alloy.
- 3 – $\frac{3}{8}$ in thick aluminum perforated cell.
- 4 – Narmco adhesive.
- 5 – Surround adhesive Hexcel HP 326.
- 6 – $\frac{3}{4}$ in birch edge finish.
- 7 – Weight 77 lb.

The final fabrication of the panel was performed by Hexcel.

It is not the purpose of the paper to discuss the restoration of the Thomas Moran painting, but rather to illustrate that the problems presented in its consolidation indicated the need

*Since these panels were constructed from commercially available materials, the standard US (non-metric) measurements have been retained throughout.

for a specific solution. The panel was totally successful—strong, lightweight, and easy to manipulate during the lining process. The all-aluminum structure allowed rapid heat transfer from the hot table to the top of the panel, permitting the painting to be lined ‘face up’ and eliminating the need for any application of additional heat to the surface of the painting. In effect, the lining technique was identical with the normal ‘face up’ procedure. While the panel for the Moran was fabricated specifically for that painting by a commercial firm with large industrial capacity, the question still remained whether a conservator could build and use such panels in his or her own studio in a reasonable time and at a reasonable cost. The design criteria and methods for fabrication and use developed by the Washington Conservation Studio outlined below indicate that the basic industrial process can be duplicated in a modern conservation laboratory.

2. DESIGN

The physical properties of aluminum are well defined and readily allow the determination of the structure necessary to support a particular work of art. In theory, support panels of a desired stiffness for small paintings would be quite thin. In practice, however, it was felt that a standard design suitable for use with a wide range of painting sizes would be more practical, as it would limit the number of materials to be stocked and simplify assembly. The design chosen is, in fact, stronger than necessary for panels under 8 ft in the larger dimension; it would suffice for panels up to 16 ft long. Although a reasonably lightweight panel was desirable, weight was not a prime consideration—ease of construction and handling were more important.

The material components of the design ultimately chosen are as follows:

- 1 – Aluminum core—Hexcel ACG, $\frac{1}{4}$ in cell, $\frac{9}{16}$ in thick, perforated.
- 2 – Aluminum core—Hexcel ACG, $\frac{1}{4}$ in cell, $\frac{1}{2}$ in thick, perforated (for internal splices).
- 3 – Aluminum skin—Reynolds Aluminum 25 mil (0.025 in) sheet (3003 H 14 alloy).
- 4 – Adhesive—Hexcelite HP 326 (two part epoxy).
- 5 – Wood edging strips milled to $\frac{9}{16}$ in, straight grained.
- 6 – Assembled weight—1.2 lb/ft².

Considering panel thickness first, the materials specified above will fabricate to approximately $\frac{5}{8}$ in. This dimension is sufficient to allow the tackover edges of the original support fabric to be adhered to the panel edges. As the aluminum honeycomb core is assembled with a surround of wood stripping which is finished flush with the top and bottom skins of the panel, these edges can readily receive staples or screws if desired. In addition, the dimension chosen ($\frac{5}{8}$ in) lends itself to the splicing technique used to build panels over 4 ft in the shorter dimension.

The aluminum skins could have been 20 mil instead of 25 mil. However, when handling sheets of aluminum this thin, it is easy to distort the surface and cause a dent. Twenty-five mil aluminum is somewhat easier to handle and proportionately more resistant to deformation.

The core (ACG $\frac{1}{4}$ in cell) is used for various reasons. First, the small cell size provides a sufficient bonding area to withstand certain thermal transitions during use on the hot table where painting attachment occurs. Second, the cell density provides a more continuous platform for the aluminum skin and eliminates the possibility of a skin surface texture caused by the cell. Third, the aluminum density of the core provides uniform heat transference from the hot table to the painting during the attachment process. Fourth, the core cuts easily, since there is an inherent stiffness, and provides the opportunity to use small pieces in the construction of the panel, thereby eliminating waste.

The adhesive, HP 326, is a thixotropic epoxy paste chosen for its strength and ease of manipulation. It takes heat well and is able to bond materials of different physical proper-

ties. This is important as panels are normally finished with wood edging strips.

It is evident that lighter weight material could be used with success, e.g. the original panel for the Moran. However, more care would be needed in the storage and handling of the materials as well as in the fabrication of the panel. Since painting size varies so greatly, it seemed wise to establish a standard design for panel construction employing materials and methods acceptable to the average conservation laboratory.

3. CONSTRUCTION

3.1. *Panels Having at Least One Dimension Under 48 in*

Step 1. *Cutting the Aluminum Skins*

Four dimensions are required: height, width, and the two diagonals. The diagonal measurements should always be taken since it is so often found that paintings are out of square. Panels can easily be constructed to fit the painting exactly and it makes little sense to do otherwise.

The dimensions are scribed on the aluminum sheet using a sharp steel point. A sharp point is necessary; otherwise, a 'strain-hardening' occurs in the aluminum after the first pass, making further scoring quite difficult. Three small indentations are made along a cutting edge and visually aligned to ensure that the measurements scribed are accurate. The actual cutting of the aluminum sheet is done as if one were cutting glass. A fairly deep trough is scribed by making several passes with the steel point. The sheet is then folded over a straight table edge with a fairly brisk motion, this right angle is continued to 180°, reversed, and usually breaks on the second fold. This method of cutting does not distort the edges and is preferable to using shears or saws.

Step 2. *Preparation of Wood Edging*

Redwood edging is used as it is fairly stable and easily worked. Strips $\frac{9}{16}$ in wide are pre-cut from a standard 1 × 6 in redwood board. It is important that the $\frac{9}{16}$ in depth of the strip be as accurate as possible because the strips must be flush with the core to eliminate any possibility of distortion of the panel surface. The surround of wood edging is a fraction larger than the aluminum skins because it is desirable to provide an excess which will be trimmed away when finishing the panel edges. While the corners can be mitred, it is not necessary. The corners are temporarily secured with brads set so that they can easily be removed later. The frame of wood strips is then taped to one of the aluminum skins and provides the guide for cutting and fitting the core.

Step 3. *Fitting the Core*

The aluminum core is worked easily if some care is used. Place a sheet of core over the assembly of wood frame and single aluminum skin, mark the inside edge of the wood strips on the core with masking tape allowing an excess of $\frac{1}{8}$ in all around. Place the core on a flat surface and, using a straight edge, cut the core with a sharp knife (a serrated kitchen knife works well), making several passes with moderate pressure. The core should now be about $\frac{1}{8}$ – $\frac{1}{4}$ in larger than the inside dimensions of the wood edging. Gently pass your finger over the edges of the core and press the excess to the proper dimension so that the core fits snugly inside the wood frame. It is not necessary that the core be a single, continuous piece. It can be several pieces, but there should be no gaps between core pieces larger than the cell dimension of $\frac{1}{4}$ in.

Step 4. *Bonding the Panel*

Hexcelite HP 326 is a two-part thixotropic epoxy adhesive which has a four-hour pot life

Studies in Conservation, 22 (1977), 177–189

at room temperature. The long pot life allows the adhesive to be mixed after cutting the pieces of the panel and still leave ample time for assembly. Excess mixed adhesive may be stored in a refrigerator for even longer life.

Usually aluminum sheets are provided with a thin coating of oil to preserve the surface finish. As this oil film can reduce bonding strength, it must be removed by washing with a solution of water and 'sudsy ammonia' or detergent, and dried. The panel skin is then evenly coated with the pre-mixed adhesive. A layer 3–5 mils thick can be evenly applied using pieces of scrap cardboard as spreaders, making sure that there is sufficient adhesive around the edges to bond the wood strips.

Lay the coated sheet on top of the honeycomb panel assembly, making sure that any tape used to hold the wood strips to the bottom skin is not overlapping a surface to be bonded. It is probable that while coating a skin, some adhesive will migrate to the other side; this can be easily removed with the same water and detergent solution used previously to clean the protective oil from the skin. Care should be taken to avoid wetting the wood. Once cleaned, turn the entire panel over on to a piece of Mylar or glassine paper taped flat to a vacuum hot table. The side inverted on to the Mylar will be the side to which the painting will be bonded, so that slight imperfections on the top side are not significant. Care should be taken, of course, to keep any imperfections to a minimum. Keep all surfaces on the hot table clean and free of adhesive; it is easily washed off prior to setting, but difficult to remove afterward.

Remove the tape and other aluminum skin and apply the adhesive as before. Replace the second coated skin of the panel assembly and align both skins. The completed lay-up should appear as illustrated (Fig. 1).

Step 5. Curing the Adhesive

Since the hot table is capable of applying both heat and pressure, it is the logical tool to use for fabrication of the panel. The most prevalent cause of panel failure during fabrication is the application of insufficient or uneven pressure. To ensure even pressure, cover the entire panel with a piece of cloth. This will keep the diaphragm from sealing to the aluminum prematurely or unevenly, preventing the complete evacuation of air. (It is essential that *perforated honeycomb core* also be used to allow for complete evacuation.) It is not necessary to use maximum pressure, although it is desirable to maintain to at least 20 in Hg of vacuum (approximately 9 lb/in²). Allow the panel to maintain a heat of 150° F for a minimum of

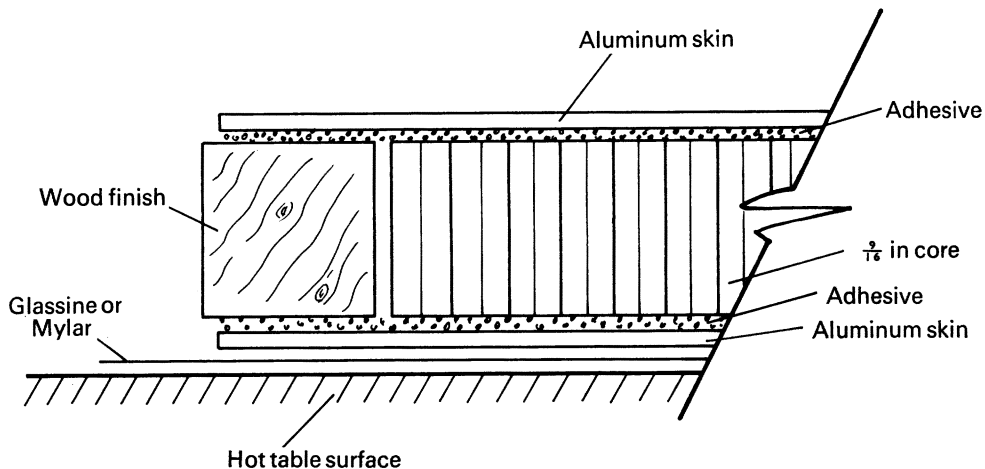

FIG. 1 Cross section of aluminum skin/aluminum honeycomb core solid support panel.

1 hour, then cool gradually under vacuum to room temperature.

Step 6. *Edge Finishing*

When the panel is cool, remove it from the hot table and remove all paper and/or Mylar. The fabric cover will probably stick at the edges where the adhesive flowed. If glassine or Mylar is used it will simply pull away. Any still attached adhesive will come away with water.

The wood edges are finished flush with the aluminum skins, first with a rasp, then with a finer wood file and emery paper. The sharp edges of the aluminum skins may be rounded at the same time. Work along the direction of the panel and not across it to avoid possible delamination of the skins from the wood. Inspect carefully the working side of the panel. Any slight imperfections may be filled with a commercial aluminum filling material and then sanded flush with the surface with a fine grade of wet sandpaper.

3.2. *Panels Having the Smaller Dimension Over 48 in*

The structural properties developed in a panel constructed of honeycomb core between two skins, or continua, provide a strong, lightweight, rigid support. However, as aluminum sheets have a maximum width of 48 in, an adjustment has been made in order to allow fabrication of panels over 48 in in their smaller dimension. It was stated previously that the core could be installed in several pieces rather than in a single continuous sheet; this cannot be said for the skins without certain other adjustments. The stiffness of a panel depends on the resistance of the skins to in-plane compression or tension stress. Skins which are butted may develop resistance to compression under certain circumstances, but cannot resist tension. The core, by separating the skins, provides resistance to shear stress, and if continuous skins are used contributes to the development of panel stiffness. The prime consideration of a panel is not shear stress but bending (or flexural) stress. As the core itself has little resistance to bending, some means of transfer of tensile and compressive stress is necessary when using a multiple piece skin. This can be accomplished by the inclusion of an internal box splice. The construction of such a spliced panel is as follows.

Step 1. *Cutting and Fitting*

Cut the aluminum skins as previously described, butting two pieces to achieve the desired size. Attach the frame of wood edging strips with tape as before. Cut two strips of aluminum sheet the length of the seam and about 5 in wide. Cut a piece of core having the thickness of $\frac{1}{2}$ in rather than $\frac{9}{16}$ in, the same dimensions as the 5 in aluminum strips, and a second 5 in skin strip. These pieces will assemble to a thickness just under $\frac{9}{16}$ in. Center the splice assembly over the skin seam and tape in place. Fill the remaining panel space with $\frac{9}{16}$ in core.

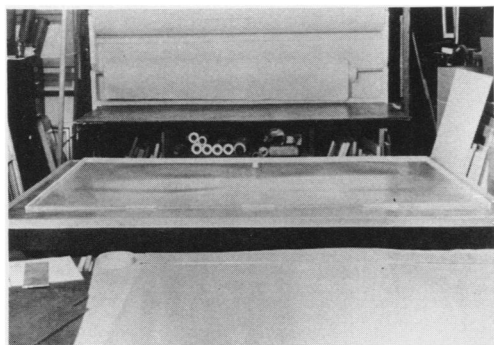

FIG. 2 Aluminum skin and wood surround—pieced before splice.

Measure and cut the second set of skin pieces. The seams of both sides of the panel must be located over the centre of the box splice (Figs. 2–5).

Step 2. Bonding

First remove the box splice from the lay-up and coat the two 5 in aluminum strips with adhesive and join them to the piece of $\frac{1}{2}$ in core. Place this assembled box splice back in place. The extra layer of adhesive used in constructing the box splice will compensate for the minor difference between the $\frac{9}{16}$ in core and the internal splice box assembly. All other steps are the same as before except that the skins will be placed in two pieces. Inverting the assembly on to the prepared surface of the hot table is precarious and will require more than one pair of hands. Coat the remaining two pieces of skin and position, making sure that

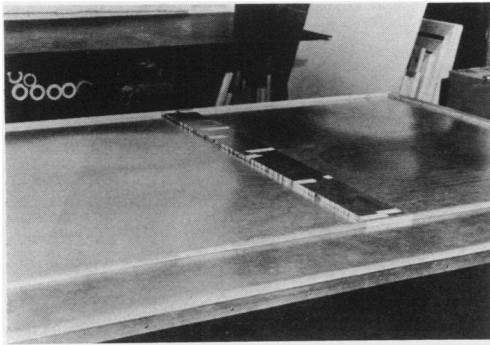

FIG. 3 Internal bridge lay-up.

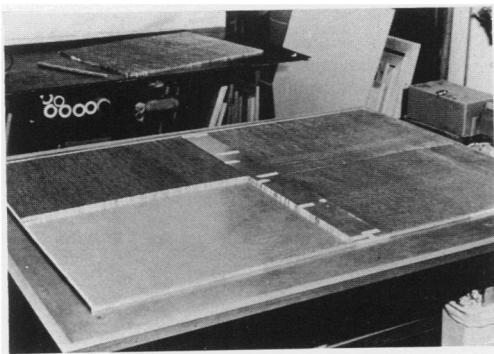

FIG. 4 Honeycomb core with internal bridge lay-up incomplete.

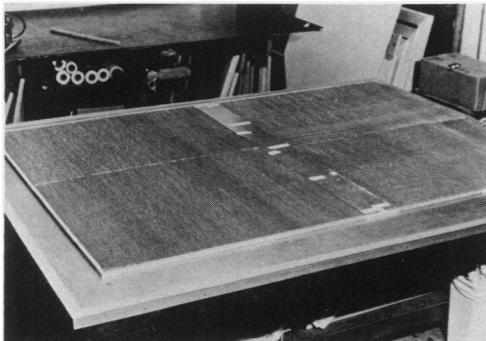

FIG. 5 Honeycomb core with internal bridge lay-up complete.

Studies in Conservation, 22 (1977), 177–189

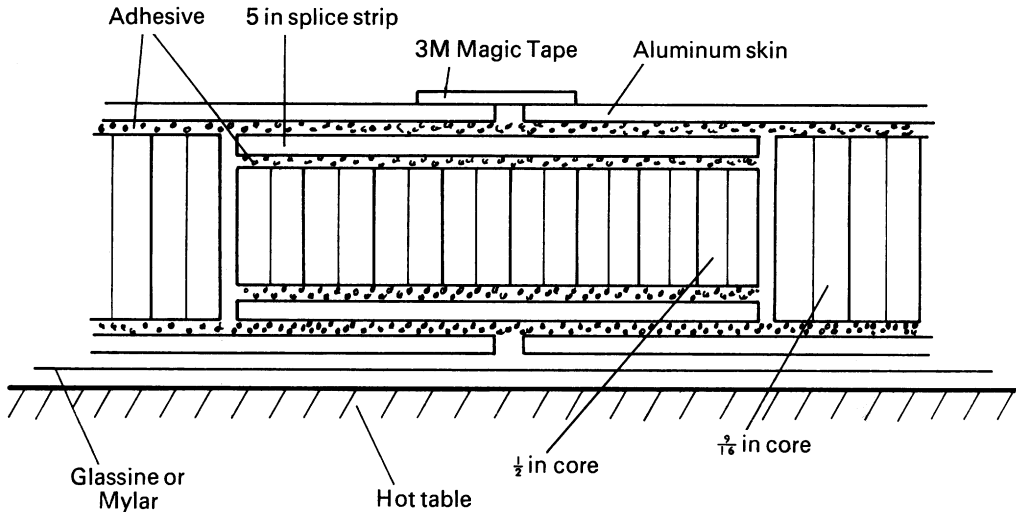

FIG. 6 Cross section of aluminum skin/aluminum honeycomb core panel with box splice.

alignment is good and that no tape remains on surfaces to be bonded.

The completed lay-up should appear as illustrated in Figure 6. Note that a piece of 3M 'Magic Tape' has been placed above the seam on the top of the panel; this prevents a flow of adhesive during the cure of the panel. No tape is placed on the bottom seam, as this is the working side and the flow of adhesive through the joint will fill the gap and provide an excellent continuous surface.

Again, cover the entire panel with cloth to provide even evacuation of air. The cure time should be slightly longer due to the additional density of the assembly. Normally an additional 15 minutes is required. A slight wet sanding with wet-dry silicon carbide paper, as described above, is recommended along the working side seam line to ensure a perfectly flat surface.

3.3. Shaped Panels

All paintings are not rectilinear. Ovals and roundels are not uncommon and irregularly shaped canvases are encountered with increasing frequency among contemporary paintings. Panels of a complex geometry present problems in the alignment of their various components during fabrication and finishing. It is necessary to establish points which will provide an accurate reference at any given time during fabrication.

The procedure used in this lab is as follows:

Step 1. Cutting a Template

An accurate template is made of the shape of the desired panel, on Mylar with a felt-tip pen, and cut out along the traced line (Fig. 7).

Step 2. Cutting the Wood Surround

The template is transferred to a sheet of high grade (A-B) interior plywood of the same thickness as the honeycomb core to be used. Plywood is used in preference to redwood strips for the surround of a shaped panel because complex curves and/or angles may be cut easily from one piece. When the shape has been accurately drawn on the plywood, the template is removed and a second line is drawn on the plywood $\frac{1}{2}$ – $\frac{3}{4}$ in inside, and parallel

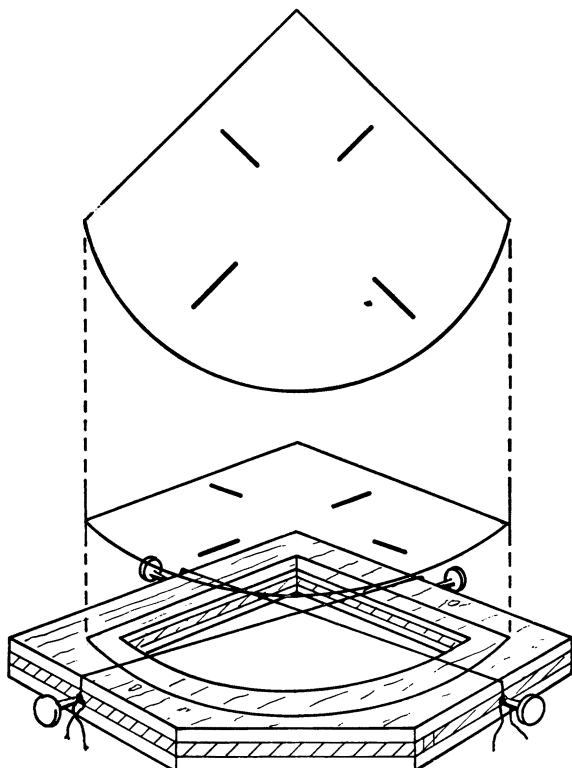

Step 1
Mylar template

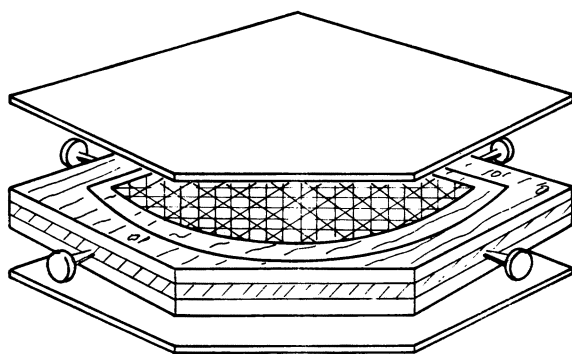

Steps 2,3
Template traced on plywood and opening to receive core cut out. Guide pins located.

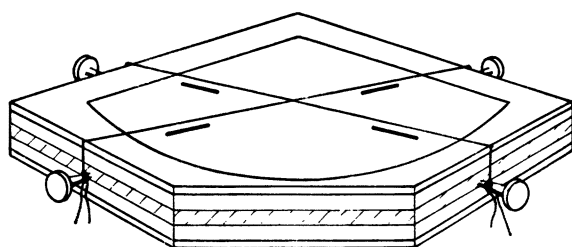

Step 4
Completed lay-up with aluminum skins and honeycomb core positioned in plywood surround. Guide pins still in place.

Step 5
Mylar template relocated after bonding to determine 'finish cut' line.

FIG. 7 Construction of a panel with complex geometry

Studies in Conservation, 22 (1977), 177–189

to, the first or 'finish cut' line. Using a sabre saw, the wood is cut along this inside line. The resulting opening will eventually receive and contain the honeycomb core. Excess wood outside the 'finish cut' line is cut away—approximating the final geometry using straight lines and simple angles and going no closer than $\frac{1}{2}$ in to the final 'finish cut' line (Fig. 7).

Step 3. *Positioning the Template*

The template is replaced on the wood and taped securely. Four brads are set into the edge of the plywood and two strings, crossing the template in different directions, are tied to each pair of brads. Where the strings cross the template, lines are drawn on the Mylar. These lines will serve to relocate the template accurately on the bonded panel allowing the 'finish cut' lines to be redrawn on the aluminum skin. Do not remove brads.

Step 4. *Preparing the Panel*

Cut the aluminum skins to conform to the temporary outside shape of the plywood. Fill the void in the plywood surround with honeycomb core and bond the panel as described in Section 3.1. above (Figs. 7, 8).

Step 5. *Finishing the Panel*

The 'finish cut' line, previously drawn on the plywood, will now be hidden by the aluminum skins and must be relocated on the surface of the bonded panel before final cutting and finishing. Replace the template on the panel and attach string to the brads as before. Adjust the position of the template so that the previously marked string lines are again aligned with the strings. Trace the template shape on to the aluminum skin carefully as this is the 'finish cut' line. A sabre saw with a fine tooth blade will cut cleanly through the bonded aluminum and plywood layers to provide the final panel shape (Figs. 7, 9 and 10).

4. USE

A bonded aluminum honeycomb panel, in effect, acts as an extension, or second surface, of the hot table. Its ready ability to transfer heat permits the use of normal face-up lining procedures. As adhesive, either a wax/resin, such as microcrystalline wax Bareco Victory White/Piccolyte S115 (5:1), or a thermoplastic, such as AYAC/AYAA (1:1) dissolved in toluene, may be used, the choice being determined by the amount of penetration which will provide both proper consolidation and the desired final surface appearance. It has been found unnecessary to sand a panel surface to provide tooth, although the surface must be clean and free from grease or oils that might interfere with proper adhesion. Since no fabric is under tension and simple bonding is the only requirement, very low pressure is adequate to mount a painting to such a panel.

Usual pre-lining procedures, such as setting down flaking, trimming and alignment of tear edges, inserts, etc., should be completed prior to mounting. If the painting is to be lined with wax/resin adhesive, it is infused from the reverse and an interleaf of either fiberglass (J. P. Stevens No. 7738) or 3M polyester fiberbat attached to the reverse with the same adhesive and cupped to remove excess. Wax/resin adhesive is also applied to the tool (working) side of the prepared panel by placing the panel on the hot table and heating it to a point where the wax/resin adhesive remains fluid, and again cupping or squeezing to remove the excess. Removal of excess wax/resin is important, since vacuum diaphragms tend to seal the edges of the panel, preventing a flow of excess adhesive.

If thermoplastic adhesive is to be used, the interleaf of either fiberglass or fiberbat is stretched on a temporary strainer, just taut enough to prevent motion, and given two coats of adhesive, allowing sufficient time after each coat for the solvent to evaporate (24–48 hours). A single coat of the thermoplastic adhesive is also applied to the tool side of the panel and

Studies in Conservation, 22 (1977), 177–189

allowed to dry. In every instance, an interleaf is used when bonding a painting to a panel. The interleaf serves two functions: one, as a cushion for a fabric supported painting against a very flat surface; and two, as a support for the painting during assembly, and should it become necessary for any reason in the future, during disassembly.

The vacuum table is then prepared with a piece of glassine, taped flat. The coated panel is placed on the glassine and the interleaf and painting carefully positioned. A breather of

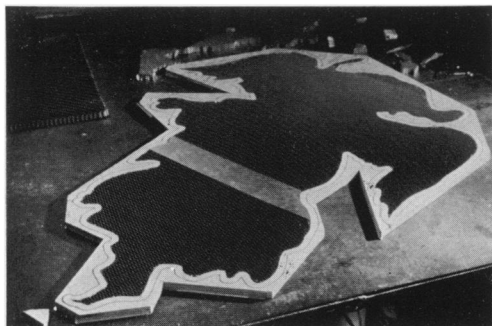

FIG. 8 Lay-up of irregularly shaped support panel*. Specifications: core—1 in thick ACG $\frac{3}{8}$ in cell aluminum honeycomb; skins—25 mil aluminum sheet; surround— $\frac{3}{4} \times 1$ in thick 7-ply waterproof plywood shape, cut $\frac{1}{8}$ in larger than the template provided; three interior fastening devices provided; internal seam box ACG $\frac{1}{4}$ in cell with 25 mil skins; adhesive—Hexcelite HP 326.



FIG. 9 Final cutting of cured complex curved panel.

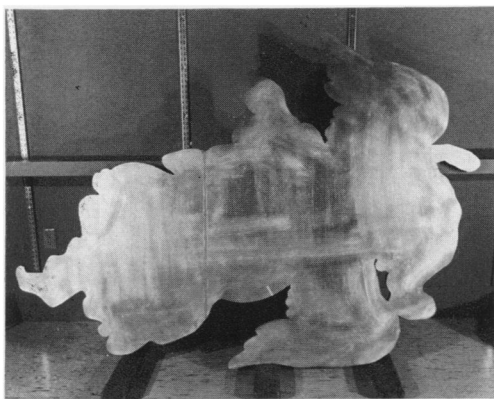

FIG. 10 Completed complex curved panel.

*Peter Paul Rubens (1577–1640). *Archangel*. Flint Institute of Arts, Flint, Michigan, USA. Conservation performed by Intermuseum Laboratory, Oberlin, Ohio, USA. Panel fabrication by Washington Conservation Studio.

linen is laid from the corner of the panel to the port, and all covered with a second piece of glassine. The assembly is then covered with a diaphragm of PVC, preferred because of its transparency and ability when heated to conform to the most complex texture. A low vacuum is applied *slowly* in order that a seal is not formed prematurely at the edges of the panel thus preventing even pressure across the surface of the painting by creating an air pocket. When the seal is complete, the surface temperature of the painting is brought to 155° F (68° C), following which it is cooled to room temperature under vacuum.

Tacking edges will conform somewhat during lining and will only require trimming and slight additional manipulation with a hand iron to attach them to the edges of the panel.

While primarily used as a structural support, large fabricated panels serve also to enlarge the working surface of smaller hot tables. For example, the large Thomas Moran painting previously mentioned was larger than the available hot table. The entire assembly of painting, interleaf and panel was surrounded by a breather of clothes line stapled to the wood edges and placed in an envelope of PVC. Vacuum hoses were attached to grommets in the envelope and air evacuated. Part of the panel was placed on the hot table and when the adhesive flowed, the entire painting, in its envelope, was moved to heat the rest of the panel. As the whole assembly was independent of the hot table, it was lifted off the table after bonding, still under vacuum, and allowed to cool. It is significant that, while one half of the aluminum honeycomb panel was heated and the other half cool, there was no distortion or warping out of plane, nor any line of demarcation on the surface of the painting. This technique is applicable whether bonding the painting to a panel or to a fabric support.

REFERENCES

- 1 STOUT, G. L., 'Changes of Attitude Toward Conservation in the Arts', *AIC Annual Meeting* Dearborn, Michigan, USA, 29 May–1 June 1976.
- 2 GOIST, D. C., 'Treatment of a Flood-Damaged Oil Painting on Solid Support', *AIC Annual Meeting*, Dearborn, Michigan, USA, 29 May–1 June 1976.
- 3 POMERANTZ, L., 'Paintings: A Method of Mounting on a Rigid Support', *AIC Annual Meeting*, Dearborn, Michigan, USA, 29 May–1 June 1976.
- 4 DUNLUCE, A., private communication.
- 5 BUCK, R. D., and MERRILL, R., 'Build Up of Honeycomb Panel *In Situ*', *IIC-AG Bulletin* 12 (1972), 62–67.

Received 21 October 1977

MARION F. MECKLENBURG received both a B.S. and M.S. in Civil Engineering from the University of Maryland. He has been a practising private painting conservator for 13 years. Mr Mecklenburg is currently conducting research into the physical analysis of the deterioration of paint film surfaces in conjunction with the University of Maryland and the Smithsonian Institution under the auspices of the National Museum Act.

JUDITH E. WEBSTER graduated from the School of the Boston Museum of Fine Arts, where she was also a technical painting instructor for two years. Both a professional painter and a designer, Mrs Webster has been a working conservator for 15 years.

Authors' address: Washington Conservation Studio, 4228 Howard Avenue, Kensington, Maryland 20795, USA.

Abstrait—La fabrication et l'utilisation de panneaux à centres alvéolés et supports pleins en aluminium pour la peinture sur tissus sont décrites, avec utilisation de matériaux et matériel de laboratoire normaux. Les techniques pour monter les peintures sur de tels supports pleins tout aluminium en utilisant la plaque de chaleur sous vide et les adhésifs à base de résine et thermoplastiques sont abordées. D'autres méthodes de fabrication des panneaux et des renseignements techniques sur les matériaux actuels sont notés.

Studies in Conservation, 22 (1977), 177–189

Kurzfassung—Die Anfertigung und Benutzung von massiven Wabenkernstruktur-Aluminiumstütztafeln für Gemälde auf Stoffgeweben unter Verwendung von Normalwerkstoffen und Laboratoriumsgeräten werden beschrieben. Techniken zur Befestigung von Gemälden an solchen ganz aus Aluminium bestehenden Abstützungen unter Anwendung des Vakuumwärmtesches sowie Wachs/Harz- als auch thermoplastischen Klebstoffen werden besprochen. Alternative Methoden der Tafelherstellung und technische Informationen über derzeitige Materialien werden angegeben.