

**Delaware Comprehensive Assessment Procedure
Coastal Plain Region
Version 5.1
Field Protocols**



**Delaware Department of Natural Resources and Environmental Control
820 Silver Lake Blvd., Ste 220
Dover, DE 19904
7/07/2008**

**Program Contact: Amy Deller Jacobs
302-739-9939
amy.jacobs@state.de.us**

This report should be cited as:
Jacobs, A.D., D.F. Whigham, D.Fillis, E.Rehm, and A. Howard. 2008. Delaware Comprehensive Assessment Procedure Version 5.1. Delaware Department of Natural Resources and Environmental Control, Dover, DE 74pp.

Table of Contents

GENERAL GUIDANCE	2
Use of Method	2
Scoring Wetland Functions and Determining Condition Categories	2
Changes from version 2.0	2
Related Delaware Rapid Assessment Procedure	2
Landowner Permission	2
Time and Effort Involved	3
Experience and Qualifications Needed	3
Equipment List	3
WETLAND CLASSIFICATION	4
A. Depression	4
B. FLAT	5
C. Riverine	6
D. Slope	7
E. Estuarine Tidal Fringe	7
F. Marine Tidal Fringe	8
G. Key to Determining Wetland Class in the Coastal Plain	8
H. Classification of Created and/or manipulated Wetlands	8
LOCATING ASSESSMENT AREA	10
LOCATING VEGETATION PLOTS (VEG PLOT) WITHIN ASSESSMENT AREA	13
LOCATING BUFFER PLOTS OUTSIDE OF THE ASSESSMENT AREA	19
DATA FORM INSTRUCTIONS	20
TREE AND SAPLING DATASHEET	20
SHRUBS AND VINES DATASHEET	22
UNDERSTORY PLOT DATASHEET	24
SNAGS/LDW DATASHEET	27
MICROTOPOGRAPHY/ SOIL/SPHAGNUM	31
NON-RIVERINE HYDROLOGY DATASHEET	34
RIVERINE HYDROLOGY DATA SHEET	36
RIVERINE MORPHOLOGY DATASHEET	37
LANDUSE IN BUFFER DATASHEET	40
BUFFER OVERSTORY DATASHEET	43
SITE INFORMATION DATA SHEET	44
APPENDIX A - DELAWARE RESTORED/ CREATED SITE INFORMATION DATASHEET	50
APPENDIX B. CLASSIFICATION OF DELAWARE’S WETLANDS USING HYDROGEOMORPHIC ATTRIBUTES AND DESCRIPTIVE EXAMPLES	54
APPENDIX C - DELAWARE INVASIVE SPECIES LIST	57
APPENDIX D - DELAWARE WETLAND MONITORING PROGRAM LANDSCAPE ANALYSIS PROTOCOLS	58
APPENDIX E - GENERATING RANDOM BUFFER PLOTS	62
APPENDIX F: SOIL SERIES OF DELAWARE AND MARYLAND	64
APPENDIX G: TIERED AQUATIC LIFE USE MODEL	65
APPENDIX H: RANDOM NUMBER TABLES	66
APPENDIX I: SOIL TEXTURE GUIDE	68
GLOSSARY	69

GENERAL GUIDANCE

Use of Method

The intended use of the Delaware Comprehensive Assessment Procedure (DECAP) is to collect data that can be used to assess the condition of wetlands in relation to minimally disturbed sites. Currently, these protocols have been tested in flat, riverine, and depressional non-tidal wetlands in the Coastal Plain of Delaware and Maryland.

Scoring Wetland Functions and Determining Condition Categories

Companion documents are available that provide protocols for scoring wetland functional categories for Buffer Integrity, Wildlife Habitat Integrity, Plant Community Integrity, Hydrologic flux and storage, and Biogeochemical Cycling and Storage and an Index of Wetland Condition (IWC) that provides an overall measure of the condition of the site. The IWC can subsequently be used to determine the condition category (minimally or not stressed, moderately stressed, severely stressed) of the site that was sampled. Protocols are currently available for flat, riverine, and depression subclasses of wetlands in the Coastal Plain of Delaware and are available from the Delaware Department of Natural Resources and Environmental Control/ Division of Water Resources/ Watershed Assessment Section.

Changes from version 2.0

Changed protocol of establishing the assessment area and locating vegetation plots. Assessment areas are no longer split when there are different disturbance histories – rather this is accounted for when placing the vegetation plots.

Related Delaware Rapid Assessment Procedure

The Delaware Rapid Assessment Procedure (DERAP) was developed to meet the needs of users that require a rapid assessment of the general condition of a wetland site. Our goal was to develop a method that could be used in any type of wetland in Delaware and that was relatively quick to perform in the field. DERAP uses a detailed stressor checklist to document indicators of disturbance at a site. A score is calculated by applying weights to each stressor based on the type of wetland being evaluated. This method was calibrated with DECAP and produces a similar scores of condition to the DECAP Index of Wetland Condition (IWC). However, DERAP does not provide the detail of information about a specific site and does not provide the information needed to score any of the HGM functions. A detailed description of the DERAP and the accompanying datasheets are available from DE DNREC/ Watershed Assessment Office.

Landowner Permission

Permission should be obtained before accessing private property. Our experience is that if contact can be made with the landowner there is a high probability that they will allow access to their property. Georeferenced parcel data can be obtained through the State intranet and landowner information can be found using the following websites:

Sussex County: <http://www.sussexcounty.net>

- Scroll to Tax Information
- Scroll to Map Search
- **Parcel ID from ArcMap:** The parcel ID that you recorded in ArcMap should resemble 532-4.00-53.

Kent County: <http://www.co.kent.de.us>

- scroll to Pride Access (Property Information)
- search Outside unless you are at the R and R building

- search by Map Number
- **Parcel ID from ArcMap:** The parcel ID that you recorded in ArcMap should resemble (MN00-83.00-01-30.01).
- The parcel ID information is entered into the corresponding boxes on the website.

New Castle County: <http://www.nccde.org/default/home/webpage1.asp>

- Click on “look up property information” (under online services)
- Enter the tax parcel number (taken from the GIS tax parcel layer)
- Use the PARCELID number found in the attributes table
- Tax parcel number should resemble: 0600200008

After parcel information is gained use a combination of phone books, postcards mailings, home visits, and letters to gain access to sites and contact landowners.

Time and Effort Involved

The time to sample a site with the DECAP will vary depending on the number of field crewmembers, the expertise and familiarity with the DECAP of the crewmembers, and the site conditions. In general, with a trained crew of 3-4 people completing the DECAP takes approximately 4 hours.

Experience and Qualifications Needed

The DECAP should only be performed by individuals who have completed a training course on how to properly perform this method. Users of this method should have experience and/or education in the identification of wetlands including an understanding of the various stressors that impact different wetland types, native flora of the region and soil properties.

Equipment List

General Equipment:

Clipboards
Pencils
Post-it-Notes (scrap paper)
Duct Tape
Bug Spray
Clippers
Sunscreen
First Aid Kit
Flagging
Compass
2-way radios
Water cooler
Knee boots
Hip Waders
Field Protocols
GPS
Plant ID tags
Zip lock bags
Data sheets

Vegetation:

Increment borer
4- 30 m measuring tapes
4- 5 m DBH tapes
Chalk
1.0 meter measuring stick
2x0.5 meter herb quadrant
NHP invasive species list

Soil:

Shovel
Auger
Drainage class table
Munsell Manual
Mid-Atlantic Hydric Soil Indicators
Metric measuring tape

Hydrology:

Line level
Metric measuring tape
String
Protractor
GPS

TASKS TO BE COMPLETED BEFORE GOING INTO THE FIELD

- 1) Determine wetland size (record on Site Info sheet)
- 2) Determine wetland stream order (riverine sites only, record on site info sheet)
- 3) Determine XY coordinates for buffer plots (see below for guidance)
- 4) Landowner Contact information
- 5) Print Maps
 - a) Wetland and hydro (1:3000)
 - b) Wetland and hydro (1:24000)
 - c) Tax Parcel (1:5000)
 - d) Road Map (1:24000)
 - e) Soils (1:5000)
 - f) Old aerials 1937, 1954, 1961, 1968, 1992, 1997, 2002 (1:3000)

WETLAND CLASSIFICATION

Although DECAP can be used on any type of wetland in Delaware's Coastal Plain Region¹, it is important to identify the type of wetland that will be assessed. There are six wetland subclasses in the Coastal Plain of Delaware (modified from Whited and Ainslie (2000). Several of these subclasses also include distinguishing types of wetlands such as intermittent low order and perennial riverine. Identification of wetlands should be performed to the lowest possible level. The most common wetland types found in Delaware are described below. A table of all wetland subclasses and types with descriptions is provided in Appendix C.

A. Depression

Wetlands located in low points in the landscape characterized by closed elevation contours that allow the accumulation of surface water. Potential water sources are precipitation, overland flow and groundwater. Depressional wetlands may have any combination of inlets and outlets or lack them completely. The predominant direction of flow is from the higher elevations toward the center of the depression. The predominant hydrodynamics are vertical fluctuations that range from diurnal to seasonal. Depression wetlands may lose water through evapotranspiration, intermittent or perennial outlets, or recharge to groundwater.

¹ Currently the DERAP has only been tested and verified on Flat, Riverine, and Depressional wetlands



Depression

B. Flat

Flats are wetlands that are most common on interfluvies, in the headwaters of watersheds, or large floodplain terraces. The landform have little change in elevation and lacks any significant slope (Watts et al.). The dominant water source is generally precipitation; however, groundwater has a varying contribution to these systems. Some flats are perched and have very little ground water contribution, whereas other flats systems receive significant inputs of ground water during late winter/ early spring when saturation of upper soil horizons from precipitation meets with saturation of lower soil horizons caused by rising ground water tables resulting in a continuous saturated soil from the surface to the groundwater table. These zones then separate when the groundwater lowers and the surface wide subsides due to evapotranspiration. Flats lose water by evapotranspiration, overland flow, and seepage to underlying groundwater. Flats transmit water to depressions in the landscape via surface and subsurface lateral flow (Watt et al.) They are distinguished from flatwood upland areas by their poor vertical drainage, slow lateral drainage, and low hydraulic gradients.



Flat

C. Riverine

Wetlands that occur in floodplains and riparian corridors in association with stream channels. Dominant water sources are overbank flow from channel or subsurface hydraulic connections between the stream channels and wetlands. Additional sources may be interflow, overland flow from adjacent uplands, tributary inflow, and precipitation. When overbank flow occurs, surface flow down the floodplain may dominate hydrodynamics. In headwaters, riverine wetlands often intergrade with slope, depressional, poorly drained flat wetlands, or uplands as the channel and bank disappear. Perennial flow is not required. Riverine wetlands lose surface water via the return of floodwater to the channel after flooding and through surface water flow to the channel during rainfall events. They lose subsurface water by discharge to the channel, movement to deeper groundwater, and evapotranspiration. Associated slope wetlands which are typically located at the toe-slope of the floodplain in the coastal plain physiographic region and are dominated by ground water inputs are included in this subclass. They are not identified as a separate subclass because they are typically very small and are always located within a riverine wetland. There are two levels of the riverine subclass (we are currently working on criteria for splitting these two groups):

Headwater – Typically first and second order streams that serve as headwaters to the watershed. These systems may or may not have a defined channel. Floodplains associated with these systems are fairly narrow and flow may be intermittent or perennial.

High order- Typically third order and higher along the mid-reach or mainstem of the system. Floodplains are wide with a defined channel and surface water is perennial.

Beaver Impounded – wetlands that are or have been impounded by beaver. Floodplains are generally dominated by herbs and emergent vegetation. Snags and dead trees may be present. Canopy tends to be open. Signs of beaver activity such as dams, lodges, chewed stumps and feeding platforms are generally present.

Human Impounded – Typically associated with wetlands along the edge of mill ponds or other manmade bodies of water.



3rd order riverine wetland

D. Slope

Wetlands normally found where there is discharge of groundwater to the land surface, either on sloping land or flat areas at the base of a slope (i.e. toe slope). The dominant hydrologic source is groundwater and flows downslope in a unidirectional flow. Slope wetland may not have a channel but if a channel is present, it carries water away from the wetland

E. Estuarine Tidal Fringe

Wetlands that occur along estuaries and rivers and are under the influence of sea level. They intergrade landward with riverine wetlands where tidal current diminishes and river flow becomes the dominant water source. Additional water sources may be groundwater discharge and precipitation. The interface between the tidal fringe and riverine classes is where bidirectional flows from tides dominate over unidirectional ones controlled by floodplain slope of riverine wetlands. Because tidal fringe wetlands frequently flood and water table elevations are controlled mainly by sea surface elevation, tidal fringe wetlands seldom dry for significant periods. Tidal fringe wetlands lose water by tidal exchange, by overland flow to tidal creek channels, and by evapotranspiration. Two subclasses are distinguished in Delaware, freshwater tidal fringe and saltwater tidal fringe.

F. Marine Tidal Fringe

Wetlands that occur along the Atlantic Coast in Delaware and are under the influence of sea level. Because tidal fringe wetlands frequently flood and water table elevations are controlled mainly by sea surface elevation, tidal fringe wetlands seldom dry for significant periods. Tidal fringe wetlands lose water by tidal exchange, by overland flow to tidal creek channels, and by evapotranspiration.

G. Key to Determining Wetland Class in the Coastal Plain

1. Is the wetland influenced by tidal cycles from a Bay or Ocean?
No – go to step 3
Yes – go to step 2
2. Does the wetland receive direct influence from the Ocean or is located adjacent to the Ocean?
 - a. Yes – Marine Tidal Fringe subclass
 - b. No – Estuarine Tidal Fringe subclass
3. Is the wetland in a valley or stream channel where it gets inundated by overbank flooding from that stream or river in an unaltered condition (i.e. if a stream has been channelized and no longer receives overbank flooding it could still be a riverine wetland in an altered condition)?
 - a. No – go to step 4
 - b. Yes – Riverine subclass
4. Is the wetland in a topographic depression, outside areas that are inundated by overbank flooding, in which water ponds during at least part of the year?
 - a. No – go to step 5
 - b. Yes – Depressional subclass
5. Is the wetland at the bottom of a topographic slope?
 - a. No – Flat Subclass
 - b. Yes – Slope subclass

H. Classification of Created and/or manipulated Wetlands

The State of Delaware, in an effort to track and report progress in the State that is comparable with other on-going tracking efforts is using the definitions as defined by the Federal Geographic Data Committee, Wetlands Subcommittee. This subcommittee developed definitions for restoration and related activities designed to aid agencies in accurately reporting wetland increases due to their program activities. The definitions, below, provide standard terminology for the more than 15 agencies involved in wetland restoration, related activities, and/or mitigation.

Restoration: the manipulation of the physical, chemical, or biological characteristics of a site with the goal of returning natural/historic functions to former or degraded wetlands. For the purpose of tracking net gains in wetland acres, restoration is divided into:

- *Re-establishment*: the manipulation of the physical, chemical, or biological characteristics of a site with the goal of returning natural/historic functions to a former wetland. Re-establishment results in rebuilding a former wetland and results in a gain in wetland acres. Restore acreage and function
- *Rehabilitation*: the manipulation of the physical, chemical, or biological characteristics of a site with the goal of repairing natural/historic functions of degraded wetland. Rehabilitation results in a gain in wetland function, but does not result in a gain in wetland acres. Restores only function, but not acreage

Establishment: the manipulation of the physical, chemical, or biological characteristics present to develop a wetland that did not previously exist on an upland or deepwater site. Establishment results in a gain in wetland acres. Create a new wetland from a different ecosystem type.

Enhancement: the manipulation of the physical, chemical, or biological characteristics of a wetland (undisturbed or degraded) site to heighten, intensify, or improve specific function(s) or for a purpose such as water quality improvement, flood water retention or wildlife habitat. Enhancement results in a change in wetland function(s) and can lead to a decline in other wetland function, but does not result in a gain in wetland acres. This term includes activities commonly associated with the terms enhancement, management, manipulation, directed alteration. Improves a specific function of a site not necessarily to reference condition

Protection/Maintenance: the removal of a threat to, or preventing decline of, wetland conditions by an action in or near a wetland. Includes purchase of land or easement, repairing water control structures or fences, or structural protection such as repairing a barrier island. This term also includes activities commonly associated with the term preservation. Protection/Maintenance does not result in a gain of wetland acres or function

LOCATING ASSESSMENT AREA

The Assessment Area (AA) is the area within a wetland that will be sampled using the DECAP. Most measurements will be performed in the AA or in relation to the AA. The center of the AA is a random point located in a mapped wetland that has been selected using a probabilistic sampling design.

Note: If this method is being used to sample a subjectively selected reference site, a center point for the AA should be located such that it is representative of the wetland and the ecological condition that it is representing (i.e. clear cut flat, channelized low-order riverine etc.).

- Mark the center of the AA with a large piece of flagging.
- Establish the AA as a 0.5 ha area around the point (40-m radius circle centered on the point)

Several situations may occur that would require that the AA to be positioned differently than above. Each of these circumstances is detailed below. Please note: **If the location of the AA is moved make detailed notes on the datasheet explaining why the AA was moved and record the lat/long of the new center:**

A. Protocol for moving or adjusting the location and/or dimensions of the AA

1. All wetlands:

- 1) Wetland does not extend 40m from the point in all directions or part of the AA goes into an adjacent upland.
 - Move the center of the AA so that the entire AA is within the wetland boundaries.
- 2) AA is within a naturally occurring upland inclusion in the wetland.
 - If the upland inclusion is due to a disturbance i.e. a pile of fill, do not move the center of the AA.
 - If the location of the original point is determined to be upland, examine the entire 40m radius circle around the original point for a wetland.
 - i) If a wetland is found within this area, move the AA the least distance necessary to locate the AA in the wetland.
 - ii) If no wetland is found within the bounds of the original AA, the site should be dropped and recorded as upland
- 3) Two different HGM wetland types within the AA (i.e. one forested flat, one depression)
 - Adjust the location and shape of the AA to be entirely within the HGM wetland where the original point was located

2. Riverine Wetlands:

- 1) Wetland is >80m wide on the side of the stream where the point falls
 - Entire AA should be located on the side of the channel where the original point fell
 - Do not include the stream channel in the AA
- 2) Wetland is <80m wide

- Include the channel in the AA if
 - a. the stream is wadable (the deepest part of the stream is <1 m deep)
 - AND**
 - b. you have permission to access both sides of the channel
- Exclude the channel from the AA if
 - a. If the stream is not wadable or permission is only received to access one side of the channel.
 - Configure the AA as a 0.5ha rectangle with the width being from the edge of the channel to the toe slope (i.e. upland).
 - If the distance varies between the edge of the channel and the toe slope, measure 5 transects, 10 m apart perpendicular from the stream to the upland. Average the lengths of these 5 transects and use this as the average width of the AA. Use the calculated average width to determine the length of your rectangle (see Figure 1).
 - Adjust the shape of the AA to a rectangle that is 5,000 sq.meters with the width being the average width of the transects (ex. If the average transect length is 50 meters, the AA would be 100m in length).
 - If the average transect length is less than 50m for the width of the AA use a length of 100m and note the width on the datasheet. The maximum length of the AA is 100m.

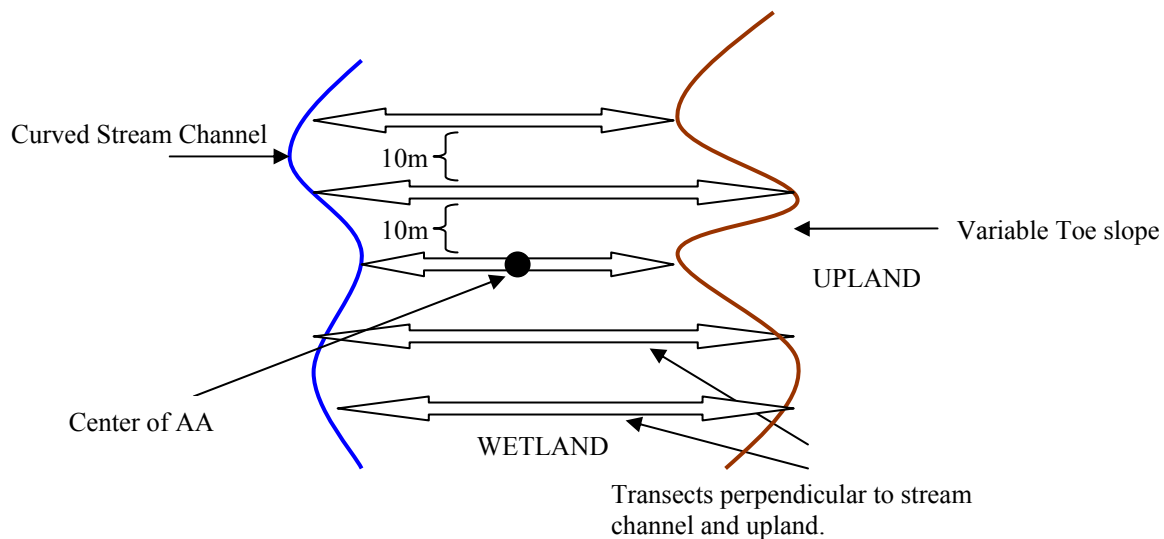

Figure 1. Illustration of how to determine the length of a rectangular AA in a riverine wetland. Use the average distance between the channel edge and toe slope as determined from the 5 transects.

3. Depressional Wetlands: Depressional wetlands are different from most flat and riverine wetlands because they often have different zones of vegetation due to the hydrologic cycles of ponding and drying. Therefore, when assessing depressions the

AA should be set up to encompass all the vegetation zones rather than just delineating a circle around a point.

- 1) Wetland is smaller than 0.75 ha (Note: the majority of depressions in the Coastal Plain of Maryland, Delaware and Virginia or <0.75 ha).
 - The AA is the same size as the wetland
- 2) Wetland is >0.75 ha
 - The AA should be a half or pie-shaped section that is 0.5ha and placed to encompass all vegetation zones present in the site. See figures 2 and 3.

Field Note: Delineating the edge of a depression

- If the depression is surrounded by upland, the AA extends to the edge of the wetland
- If the depression is bordered by or surrounded by a flat, the AA extends to the edge of the depression as delineated by highest elevation surrounding the depression that would be inundated at full pool.

Figure 2: Depression that is 1.0 ha

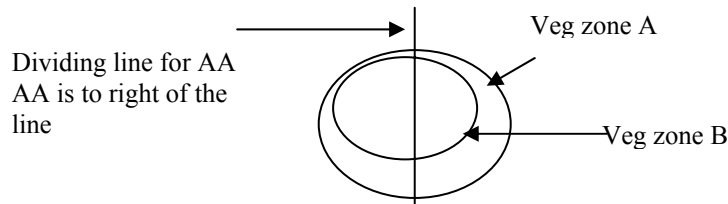
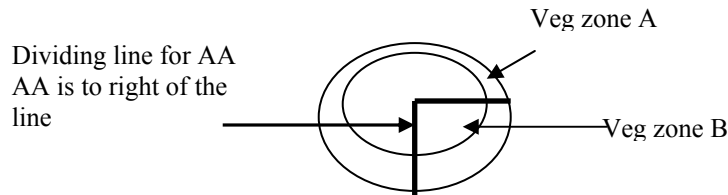

Figure 3: Depression that is 2.0 ha



4. Flat Wetlands:

- 1) Wetland is ≤ 0.5 ha
 - The AA is the same size as the wetland
- 2) Wetland is ≥ 0.5 ha, but oddly shaped and 40m radius circle will not fit
 - Adjust shape of AA to create 0.5ha AA without upland inclusions. Note the new dimensions and shape of the AA on the datasheet.

LOCATING VEGETATION PLOTS (VEG PLOT) WITHIN ASSESSMENT AREA

There are several steps required to determine the number, shape & placement of vegetation plots within the AA.

1) Number of Plots:

- i) Identify the number of dominant vegetation zones in the AA that cover \geq 10% of the AA (i.e. mature forested, emergent, recently clear cut, farmed, open water, etc.).
- ii) Based on the percent of each vegetation zone, determine the number of plots to be placed in each vegetation zone using Table 1.

Table 1. Number of vegetation plots to be sampled in each vegetation zone based on the percent the AA.

Percent AA of vegetation zone	No. of vegetation plots
10	1
15	1
20	1
25	1
30	1
35	1
40	2
45	2
50	2
55	2
60	2
65	2
70	3
75	3
80	3
85	3
90	3
100	3

 **Special Note:** Only place one representative vegetation plot if the dominant vegetation type of the wetland is a highly disturbed and monotypic area (i.e. a mowed grass area, farm field etc.) that meets all the following criteria:

- (a) Area highly disturbed and has a recurring disturbance that prevent succession
- (b) Species richness very low
- (c) no trees
- (d) no shrubs

1) Size and Shape of Vegetation Plots:

- a) Use 8.92m radius circular plots (1/40th hectare or 0.025ha) if the vegetation zone is large enough to accommodate
- b) Vegetation zone is a narrow, linear zone (i.e. small floodplain or semi-circular zone around a depression)
 - The plot should be 250 m² in a rectangular shape with the width being equal to the width of the floodplain or vegetation zone (See Table 2 lists for rectangular plots dimensions).
 - If the floodplain or vegetation zone is <5m wide, make the length of the vegetation plot 50m and record the new area.

Table 2. Length of a 250 m² rectangular vegetation plot based on various floodplain widths

Width (m)	Length of Vegetation Plot (m)
≥18	Use circular plot
17	14.7
16	15.6
15	16.7
14	17.9
13	19.2
12	20.8
11	22.7
10	25.0
9	27.8
8	31.3
7	35.7
6	41.7
≤5	50

- c) If a 250 m² plot of any shape will not fit in the vegetation zone (or would extend >50m for rectangular plots, make the plot a portion of either a circle or rectangle and note the dimensions on the datasheet. Suggestions for alternate plot sizes are listed in Table 1.

Table 3. Alternate plot sizes for areas where a 250m² plot will not fit

Proportion of a hectare	Square meters	Radius
1/40	250	8.92
1/50	200	7.98
1/60	167	7.29
1/70	143	6.75
1/80	125	6.31

1/90	111	5.94
1/100	100	5.64

❁ Special Note for Riverine Wetlands: Inclusion of the stream channel in vegetation plots :The stream channel should only be included in vegetation plots when

- the channel width and the riverine wetland (floodplain) are essentially the same. This typically only occurs in headwater streams that have braided channels that often change course across the floodplain.
- the floodplain is too narrow to encompass a vegetation plot on one side (<18m wide on each side).
- If a defined channel is included in the vegetation plot, do not place any understory sub-plots in the channel.

2) Placement of plots within the AA

- a) AA is a circular 0.5ha area and one vegetation type.
 - i) Randomly select a compass bearing between 0 and 360.
 - ii) Using the random number table (appendix) randomly select a distance between 11 and 31m. This is the distance along that bearing from the center of the AA. This is the center of the first vegetation plot.
 - iii) **Locate the 2nd and 3rd plots from the center point of your AA.**
 - iv) The second plot is determined by adding 120 to the first compass bearing and selecting a new random distance between 11 and 31m Repeat this process again to place the 3rd vegetation plot
- b) AA is rectangular (i.e.50x100) and one vegetation type
 - i) Divide the AA into thirds length-wise (i.e. 33.3 meters)
 - ii) Randomly select from which side (upland or stream side) of the wetland where the plots will be placed.
 - iii) Within each third, randomly select a length (i.e. between 9 and 27) and width (i.e.between 9 and 41) that is >9m from each side where the center of each vegetation plot will be located, making sure that the entire plot is within the AA.

Figure 4. Locating vegetation plots in a rectangular assessment area

Randomly selected side of rectangle from which to measure the vegetation plots

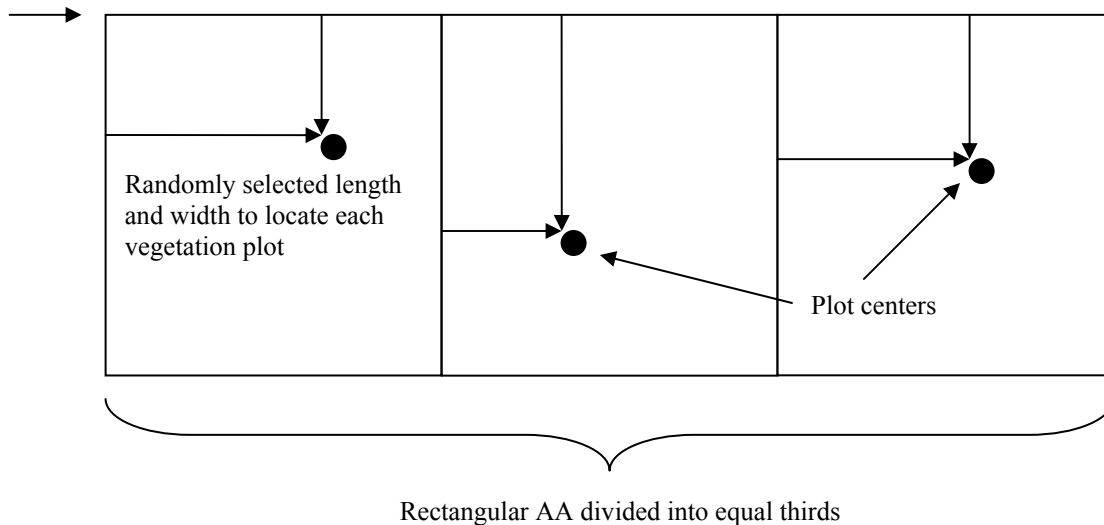

- c) AA is <0.5 ha and/ or there are multiple vegetation zones
 - randomly place the vegetation plot(s) within the zone by selecting a random number (from random number table)
- d) Depressions
 - Place one of the vegetation plots centered in the middle of the depression, if the vegetation zone in the center of the wetland is <8.92m radius then reduce the size of the vegetation plot to fit in the vegetation zone
 - If a second plot will fit in the center vegetation zone, randomly place it by using the random number table to select an azimuth and distance from the center
 - Place at least one plot in the forested fringe or the outer edge of the depression, this zone starts at the outer edge of the depression (see Field Note below for determining the edge of the depression). If the depression has an emergent or scrub shrub center it will be forested surrounding the emergent/scrub shrub vegetation zone. If the entire depression is forested, it may be a more densely forested zone or the depression may all be similar.
 - Select a random azimuth, place the plot in the depression but at the outer edge. If the zone is >17.84 use a circular plot, if not use a rectangular plot (see figures 5 and 6)

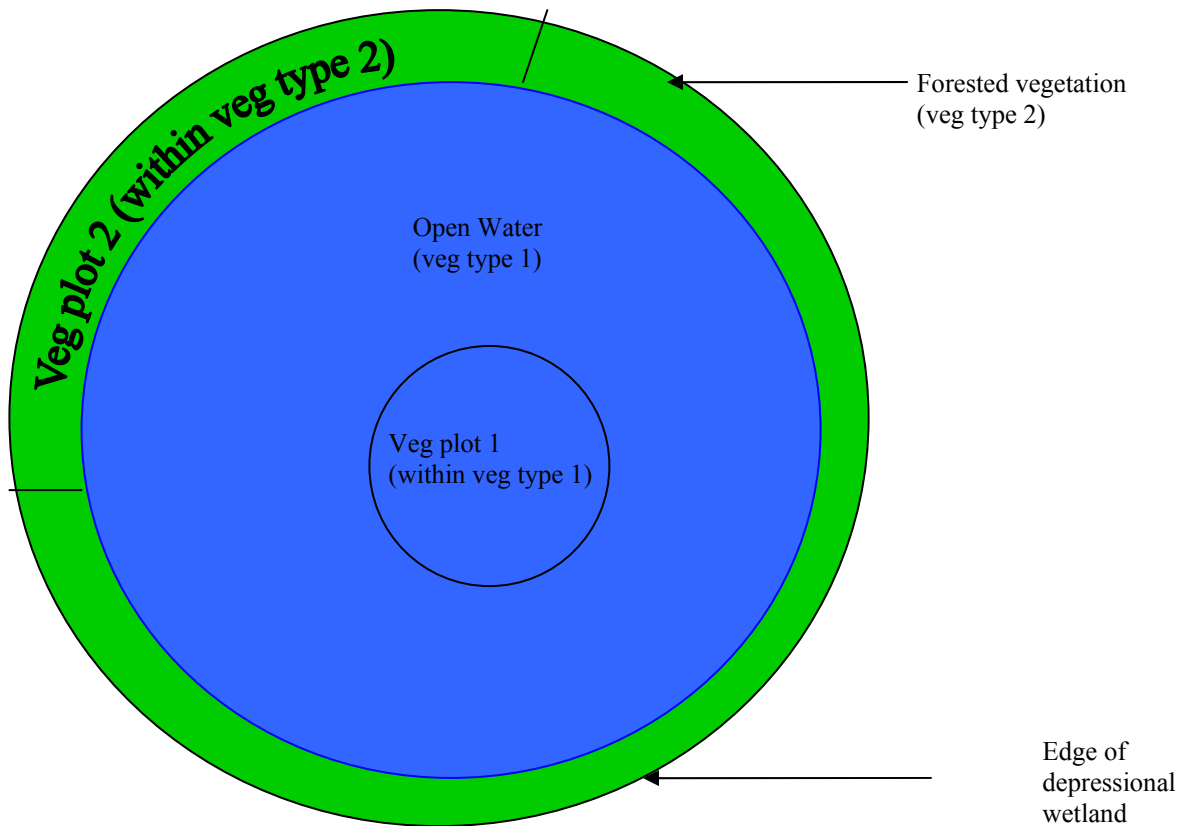

Figure 5: Location of vegetation plots in a depression <0.75ha

Field Note: Delineating the edge of a depression

If the depression is surrounded by upland, the AA extends to the edge of the wetland

If the depression is bordered by or surrounded by a flat, the AA extends to the edge of the depression as delineated by highest elevation surrounding the depression that would be inundated at full pool.

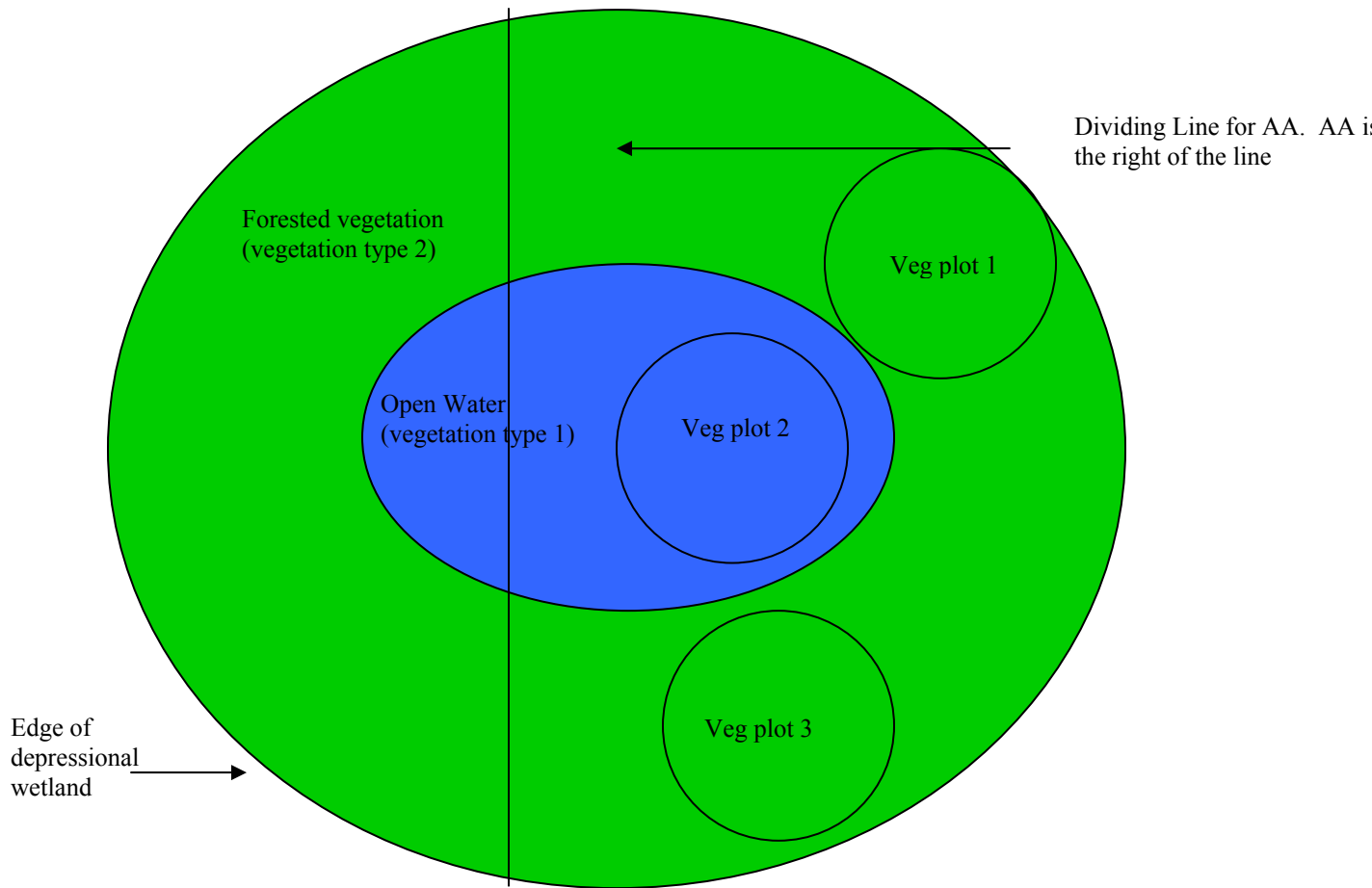

Figure 5: Location of vegetation plots in a depression 1.0 ha

LOCATING BUFFER PLOTS OUTSIDE OF THE ASSESSMENT AREA

The buffer is the area of land in a 200m radius from the edge of the AA (i.e., 240m from the random point/center of the AA). One buffer plot is located in each forested cover type that comprises >10% of the buffer area (i.e. upland hardwood, palustrine forested). Within each forested cover type randomly select a direction/bearing and distance that is at least 9m from the edge of the AA. This point is the center point of the buffer plot. It is recommended to locate buffer plots using a GIS platform before sampling (see instructions in Appendix E)

DATA FORM INSTRUCTIONS

GENERAL HEADER INFORMATION

Site #: Unique number for site

Site Name: Names are given to each site

Date: Month, day and year of sampling

Observers: All members of the field crew that participated in collecting data on this sheet

Veg Plot #: Record the number of the vegetation plot where measurements are being taken

Plot size – Record the radius of the vegetation plot in meters or if the vegetation plot is not a circle write the dimensions of the plot in the space provided

Vegetation Zone – Record the vegetation zone that the vegetation plot is in, i.e. forested, emergent etc.

Field Tip: Trees and Saplings can be recorded simultaneously if one person records the data and another measures and identifies species.

TREE AND SAPLING DATASHEET

I.A. Trees

What to measure: All trees that are ≥ 7.5 cm Diameter Breast Height (DBH) **and** ≥ 1.28 m in height

How to measure: Measure the diameter (DBH) of each tree ≥ 7.5 cm in diameter. On the data sheet, record the species and diameter, in cm to the nearest tenth, of each individual that is encountered. DBH is measured at 1.28 m from the highest above-ground point of the tree trunk. If branches or bulges occur on the tree trunk the DBH should be recorded immediately below the branches or bulges. If trees have vines attached to the trunks at the point of the DBH measurement, attempt to pull the vine away so that you only measure the tree trunk. For trees with multiple trunk stems, stems are counted as individual trees if they split lower than 1.28 m from the ground. If the tree splits over 1.28 m from the ground, only measure the trunk at 1.28 m. After measuring a tree, place a small mark with chalk to avoid measuring any trees twice.

Where to measure: Measure in vegetation plots which are located according to the protocols described above. Vegetation plots are 8.92m radius (17.84m diameter)

circular or rectangular plots equaling the same area (0.025ha). Trees on the edge of the circular plot should be checked for their inclusion within the plot by running a 8.92-meter tape directly to the center of the tree from the center of the tree plot. If the center of the tree is outside the plot do not record.

Equipment needed: DBH tapes, (3) 30-m measuring tapes, chalk.

II.A. Saplings:

What to measure: All trees that are <7.5cm Diameter Breast Height (DBH) **and** \geq 1 m in height

How to measure: Count the number of stems for each species of tree meeting the definition. On the data sheet, record the species and number of individuals that are encountered. After counting a sapling, place a small mark with chalk to avoid measuring any trees twice. *When the sampling for each plot is complete, the recorder should tally the number of counts for each line and record this number under the line total column.*

Where to measure: Measure in vegetation plots which are located according to the protocols listed above. Vegetation plots are 8.92m radius (17.84m diameter) circular or rectangular plots equaling the same area (0.025ha). Trees on the edge of the circular plot should be checked for their inclusion within the plot by running a 8.92-meter tape directly to the center of the tree from the center of the vegetation plot. If the center of the tree is outside the plot the tree is not recorded.

Subsampling – If saplings are very dense in the plot, the plot may be subsampled by randomly selecting either $\frac{1}{2}$ of the plot or $\frac{1}{4}$ of the plot. Write on datasheet if this is performed. **Note:** if plot is subsampled, the un-sampled portion of the plot should be examined for species that were not recorded in the sampled portion. Record additional species on datasheet and “un-sampled” under the count column.

Equipment needed: DBH tapes, (3) 30-m measuring tapes, chalk.

SPECIAL CASE: When a live tree is lying at less than 45 degrees to the ground, the tree should be counted as a tree, not a snag or Large Downed Wood (See below for snag discussion). The DBH of the tree should be measured as best as possible. In addition, any branches sticking out of the tree that are over 1m tall AND within 1m of the ground should be counted as saplings.

SHRUBS AND VINES DATASHEET

Subsampled? The vegetation plot can be subsampled for shrubs if the density of shrubs is > 100 in each quarter of the plot (this guideline needs to be tested to see if it is reasonable). If the plot is subsampled for shrubs circle yes, if the entire tree plot was sampled for shrubs circle no. If the vegetation plot was subsampled, write in what percent of the plot of was subsampled (i.e. 50%, 25%). **Note:** if plot is subsampled, the un-sampled portion of the plot should be examined for species that were not recorded in the sampled portion. Record additional species on datasheet and “un-sampled” under the count column.

Vegetation Zone – Record the vegetation zone that the vegetation plot is in, i.e. forested, emergent, etc.

Observers: All members of the field crew that participated in collecting data on this sheet

I. Shrubs:

What to measure: Shrubs are woody species, which do not have the potential to become canopy trees. To be counted as a shrub, the plant can be either a single shoot or a clump of shoots that originate from a single root system; the minimum height for shrubs is 1.0 m. *When the sampling for each plot is complete, the recorder should tally the number of counts for each line and record this number under the line total column.*

How to measure: Count the number of stems of each species within the plot that are $\geq 1.0\text{m}$ tall. If several stems originate from the same base, count them as individual stems. If stems split below one meter above the ground count each stem if (1) they are over one meter in length from the point where they split and (2) any part of the stem/branch exceeds one meter from the ground in height. Keep a tally of the number of stems for each species and at the completion of sampling record the total number of stems for each line on the datasheet. **Note: if more than one line is used to record stems of a species provide a total for each line, NOT a total for the species.**

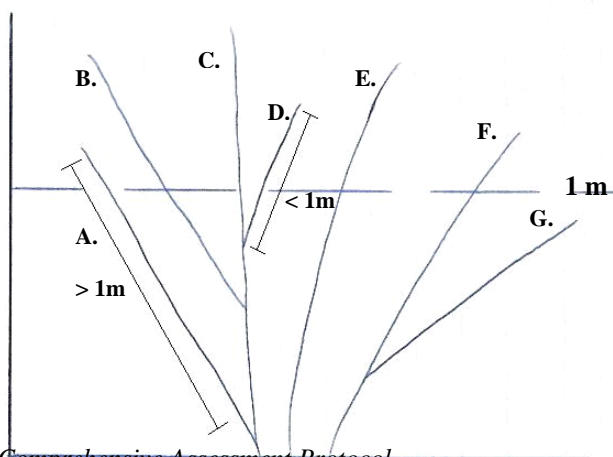

A. count, stem originates below 1m and is more than 1m in length

B. count, stem originates below 1m and is more than 1m in length

C. count

D. do NOT count, stem originates below 1m, but is $< 1\text{m}$ in length

E. and F. count

G. do NOT count, stem originates below 1m, but does not reach 1m in height

Unidentified Species: if a shrub cannot be identified in the field, collect a sample of the species and place an “x” in the column under C for collected. Once the specimen is identified be sure to place an “x” in the column under I for identified. The name should be changed on the datasheet and recorded in the species id file as part of the computer database.

Where to sample: In each vegetation plot

Equipment needed: 2 measuring tapes and 1.0m measuring stick.

II. Vines

What to measure: Woody or perennial vines such as *Smilax*, *Toxicodendron*, *Campsis* etc. that are ≥ 1 meter tall.

How to measure: Record the species that are present in the plot

Where to sample: in each vegetation plot, **do not subsample**

Equipment needed: Measuring tapes to delineate plot.

III. Blackberry:

What to measure: *Rubus allegheniensis* and other blackberry species. Do not include any *Rubus hispidus* (dewberry).

How to measure: Record the presence or absence of *Rubus* spp.

Where to sample: In each vegetation plot, **do not subsample**

Equipment needed: Measuring tapes to delineate plot.

UNDERSTORY PLOT DATASHEET

A single data sheet will be used to record data for herbs in each 0.025 ha vegetation plot. Herbs will be sampled in four 1m² subplots (0.5m x 2m) in each 0.025 ha vegetation plot.

I. Understory Species

What to measure: The percent cover of all understory species including woody and herbaceous species that are < 1.0m or the height of the tallest herbaceous species. This includes woody species, herbaceous species and Sphagnum sp. For example in a forested area with sparse understory record everything under 1m tall, in a cattail marsh record everything that is under the height of the cattail.

How to measure: Estimate the cover class of each species and unvegetated ground in each 1m² quadrat. Record the midpoint of the appropriate cover class. Cover classes and their midpoints are listed on the datasheet. When recording the percent cover of vegetation use the following guidelines:

- Lay the plot down as to not disturb the understory vegetation, if the area is very dense i.e. a cattail stand assemble the plot around the vegetation.
- Estimate the cover of all species that are contributing to the understory within the plot and are either < 1m tall or the less than the height of the tallest herbaceous vegetation whichever is greater.
- If a plant is rooted outside of the plot but is contributing cover to the understory of the plot then include this species in the cover estimates, i.e. a plant is leaning into the plot from the outside. Make sure that this situation is not caused artificially when laying down the plot.
- If a plant is rooted in the plot but most of the leaves are leaning outside of the plot, record the presence of this species in the plot but with a low cover class (note exceptions to this below for woody shrubs and trees)
- If a tree or shrub is in the plot and there are no vegetative leaves <1m do not record the presence of this species in the understory or include in the unvegetated calculation (these species will be recorded in the tree and shrub datasheets)
- If a tree or shrub is in the plot and part of the leaves and branches are < 1 m, include the parts < 1m in the cover estimates.

Where to measure: 4, 2 x 0.5 meter quadrats (1m²). Plots should be placed at the midpoint of each transect that perpendicularly bisect the vegetation plot. If the plot is 8.92m radius then the center of the plot should be placed at 4.4m along each transect (Figure 1). The plots should be placed longways in the vegetation plot. If the vegetation plot is rectangular place one understory plot in each quadrat in the center of the plot along the transect (Figure 2). If the vegetation has been disturbed by walking along the transect place the plot off to the side of the transect in an undisturbed area by randomly selecting which side of the transect to place the plot. See diagram below.

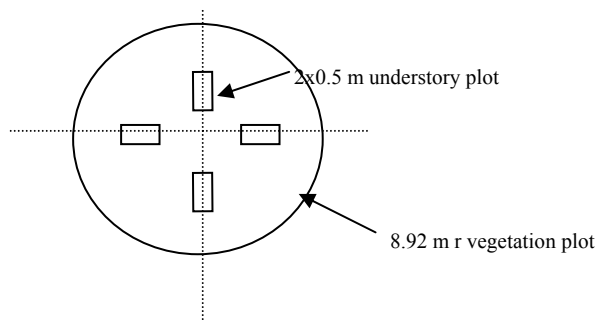
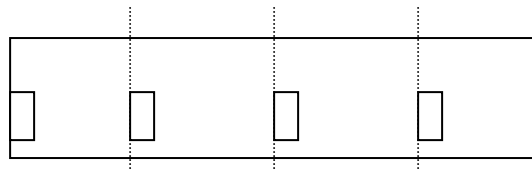

Figure 2. Rectangular plot example



Equipment needed: 2 x 0.5m herb plot quadrat

I. Additional Understory Species

What to measure: All additional understory species (<1.0 meters) not recorded in one of the understory plots.

How to measure: Starting at a known location in the plot, begin recording all the species present and continue in a manner to cover the entire plot. We recommend recording species in one quarter of the plot before continuing to the next quarter.

Where to measure: In each vegetation plot, continue on back of sheet if necessary

Equipment needed: 2 measuring tapes to delineate plot

Unidentified Species:

The following process should be used for species that can not be identified in the field:

1. Collect all unknown species, however, DO NOT collect a specimen where there is only one plant to avoid any impact to rare and threatened species. If this is the case take detailed notes about the plant or attempt to key it out in the field. Collected species should be pressed so as to include the whole plant (flower and roots).
2. Include a label with each collected plant and name all unknowns starting with UK(i.e. UK Carex #1) as opposed to things that are not

identifiable should be named xxxx sp. (i.e. Carex sp.). See figure x. for an example of a detailed plant label.

3. All plants that are collected should be pressed the same day. Labels should be taped to newspaper because they have a tendency to fall out as things get moved around.
4. Datasheets and collected plants should be cross-referenced to make sure that all plants that are marked as collected are accounted for and all plants that are pressed are marked collected on datasheets
5. If any plants are missing this should be noted and re-collected if possible
6. A datasheet of unknown plants should be inserted into each folder that contains the names of all the unknown plants that were collected and a column for the name of the plant once identified
7. Identify plants
8. Record the identified plant name on sheet in folder.
9. Change all UK species on datasheets to identified name by crossing out the old name and writing in the new name. If there is not enough room on the datasheet to do this, then erase the old name and write in the new name. Initial any changes.
10. If the data has been entered into a database replace the UK species with the identified species names.

Plant Name	_____
Plant ID	_____
SiteID	_____
Site Name	_____
HGM Class	_____
Plots	_____

Date	_____
Collector	_____
Notes	_____

Figure 3. Example of a plant label to include with a collected specimen

SNAGS/LDW DATASHEET

I. Snags

What to measure: Snags are standing dead trees (i.e. no live leaves present) ≥ 15 cm DBH and ≥ 2 meters in height. Snags are at a greater than 45 degree angle in relation to the ground

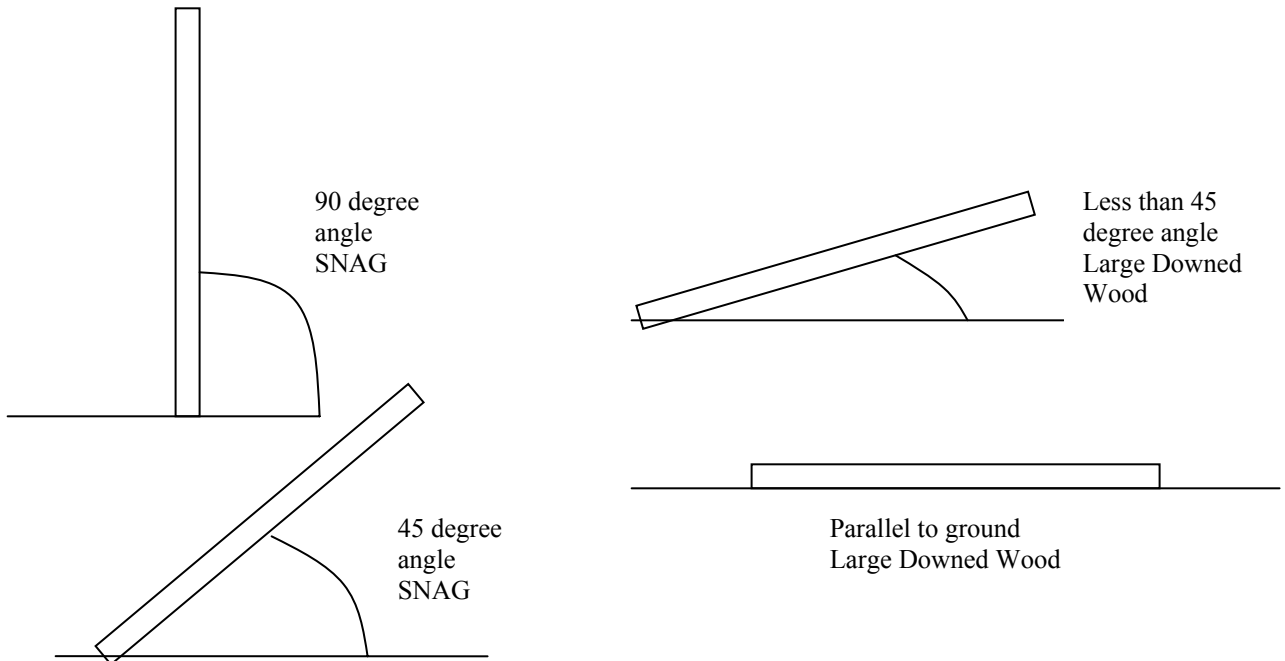

How to measure: Measure the dbh of all snags at 1.28m and record each measurement, species is not recorded

Where to measure: In the entire AA. Members of the field crew should each take a section of the AA to assess. For example if 4 crew members are present then each member should walk $\frac{1}{4}$ of the AA and record snags.

Equipment needed: DBH tape, 2- 30m measuring tapes

II. Large Downed Wood

What method to use: Line Intercept Sampling Method

Line Intercept Sampling Method

What to measure: The diameters and angle relative to the ground of all pieces of LDW and Fine woody debris (FWD) along randomly located transects. Pieces that have had more than 50% of their spatial volume lost due to decomposition are not measured.

Pieces lying at greater than 45 degree angles (relative to the ground) are considered snags and should be measured as such. Uprooted stumps should be measured as LDW, but undisturbed stumps should not be measured. Submerged pieces lying in a wadable stream should be measured as LDW.

Circular Assessment Area

How to measure: From the center of the AA select a random compass bearing. Run a transect to the edge of the AA along this compass bearing (i.e. a 40m transect, Figure 4C). A second crew member walks the transect and records the diameters of all pieces of LDW (>15cm) and tallies the number of CDW (15 cm) at the point where the sampling plane of the transect intersects the central axis of the piece.

- If the sampling plane intersects the end of a piece, the diameter should be measured only if the central axis is crossed (Figure 4A).
- If the transect crosses a piece more than once (i.e. curved or branched pieces) measure the diameter each time it is crossed (Figure 4B).
- If a piece is crossed that is not lying flat on the ground, then the angle between the ground and the piece should be measured. This angle must be between 0 and 45 degrees because pieces lying at greater than 45 degrees relative to the ground are considered snags.
- If the sampling plane intersects a curved piece more than once, measure each diameter.

At the end of the 1st 40m transect add 120 degrees to the original compass bearing and walk another 40m transect. At the end of the second transect add 240 degrees to the original compass bearing and walk another 40m transect. This will create a triangle and you should end up back near the center of the AA. After the first triangle is completed return to the center of the AA. A second triangle should be started by adding 180 degrees to the original random compass bearing. This will make the second triangle go the opposite direction of the first. This method should be repeated until a total of 200m of transect are run. If 1/3 or greater of the number of the transects will lie along the length of a road or ditch where LDW has been removed, select another random direction for transect placement (this situation should rarely occur).

Non-circular Assessment Area

If the AA is other than a 40-m radius circle, randomly locate transects so that at least a total of 200m of transect is sampled. In a rectangular AA, use the center axis as the line that splits the AA in half. First determine the dimensions of the AA (e.g. 50 by 100m rectangle). Transects will originate from randomly selected locations along the center line of the rectangle. This center line should never be more than 100m. To determine the beginning point of the transect, randomly choose a distance along the center line and a compass bearing. The transect should run along that compass bearing and along the 180 degree opposite of the compass bearing. If the AA is 5000 square meters this method should be repeated until 200m of transects are run. If the AA is less than 5000 square meters refer to the chart below to determine the total length of the transects needed. If 1/3 or greater of the length of a transect will lie along the length of a road or ditch where LDW has been removed, select another random direction for transect placement (this situation should rarely occur).

Where to measure: In the AA.

Equipment needed: 1- 50-m measuring tape, calipers

Common rectangular plot sizes and associated area of AA. Length of transect will vary if the AA is less than 5000 square meters. Any AA 2000 m² or less should have 100m of transect run

Common rectangular plot sizes	Assessment Size (m ²)	Length of transect
50 by 100	5000	200
40 by 100	4000	160
30 by 100	3000	120
20 by 100	2000	100
10 by 100	1000	100

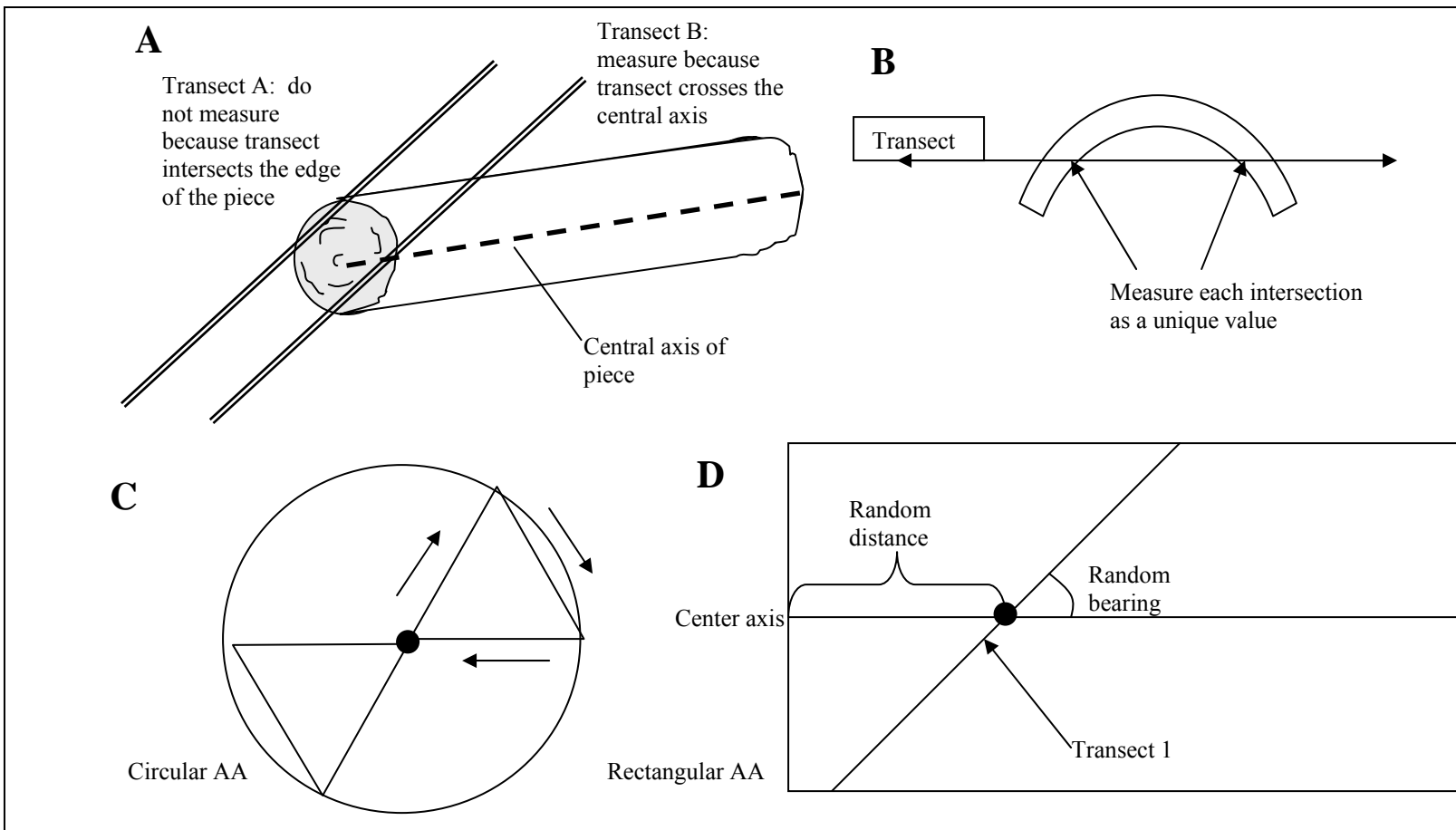

Figure 4. Sampling procedures using the line intercept sampling method. (A) measure intercepted pieces only if the transect crosses the central axis of the piece, (B) if a piece is crossed more than once by the same or different transects, measure each intersection as a

unique crossing, (C) layout design of transects in a circular AA, (D) layout design of transects in a rectangular AA

MICROTOPOGRAPHY/ SOIL/SPHAGNUM

I. Microtopography

What to measure: Hummocks are defined as areas that are at least 15cm in height from the ground level of the wetland. These areas can be either tufts of vegetation or roots, logs, or debris that has accumulated and made a higher elevation and thus a different microenvironment than the surrounding area. Many times these areas have different or more diverse vegetation and harbor more seedlings than lower areas. For this exercise two categories of hummocks are recorded (1) tip-ups and (2) hummocks. Tip-ups are mounds created by the root systems of a fallen tree. The root system and tree can still be distinguished with or next to the mound, a small depression or hollow is also usually associated with a tip-up where the tree used to be rooted in the ground. Other hummocks are any mound type feature that is over 15cm tall. These can be created from soil or root mounds of vegetation such as sedge tussocks or shrubs and create a different microenvironment than the surrounding surface due to a higher elevation.

How to measure: Divide the vegetation plot into 4 quarters. In each record the presence or absence of tip-ups and other hummocks. Repeat this process in each quarter of the plot.

Where to measure: In each vegetation plot.

Equipment needed: 2, 30m measuring tapes for delineating the plot



Example of a hummock

II. Soils

What to measure: Soils properties including the presence and depth of an O and A horizon, the drainage class of the soil, and the hydric indicators that the soil meets.

How to measure: On the datasheet record the soil series according the soils map layer for the area. Dig a hole with a shovel at least 30cm deep (a deeper hole may be required depending the depth of the horizons). If the profile does not represent the series listed, make a note that it could be a different series. Examine the soil and record the depth in cm of the O and A horizons, if any of these are not present record not present on the datasheet. Also record any comments about the layer that may be used for identifying hydric soil indicators such as texture and color. Record if the soil profile has a plow layer. Record the drainage class of the soil by referring to the drainage class table (see below) and the soil series as identified by the most recent soil survey. Record the hydric soil indicators that are present according to the Mid-Atlantic Hydric Soil Indicators manual by reading the description for each indicator and determining if the criteria are present in the soil to meet the specifications.

Where to measure: In the center of the Assessment Area. Confirmation of the spoil type should be made at each vegetation plot

Equipment needed: shovel, drainage class table, Munsell color chart, Mid-Atlantic Hydric Soil Indicators manual, metric measuring tape, soils map

III. Sphagnum

Collect sphagnum from each subplot that contains sphagnum. Take a sample about 1 inch by 1 inch and put into the paper bag, fold over top and keep in cool, dry place. On the bag record the date collected, the site ID, plot number and sample number. On the data sheet include a brief description of the habitat and moisture regime. Moisture regime should be recorded as dry, soil inundated (Water on soil surface), soil saturated (water within 15cm of soil surface). Take detailed notes of where the sample was collected. E.g. at base of tree, on top of rotting log, on bare soil, etc.

NON-RIVERINE HYDROLOGY DATASHEET

I.A. Determining the depth of mapped ditches

What to measure: Depth of all mapped ditches in the AA in cm

How to measure: Using the map depicting the location of ditches within a 240m radius of the center of the AA, walk to each ditch that is mapped and take a minimum of 3 depth measurements 25m apart from each other. Using the line level and string, attach the string to one side of the ditch at the perceived ground level elevation, this may be below the actual top of the bank if there is spoil piled here. Attach the other end of the string to the opposite side of the ditch when the bubble in the line level is in the middle. To determine the depth, measure the length between the string to the bottom of the ditch. The bottom of the ditch is the deepest part of the ditch and is determined by removing any loose debris from the bottom of the ditch and measuring to the top of the soil surface.

At each point record the following information on the datasheet:

- Depth of ditch
- Lat/long coordinates from GPS
- Distance from center of AA
- Degrees to center of the wetland (180 reverse from what is on GPS or take compass bearing pointing back to center of AA)

Where to measure: at a minimum of 3 locations at least 25m apart from each other along the ditch that are representative of the average depth of the ditch, more measurements may be needed if the ditch changes directions or curves. Avoid areas that are unusually deep or shallow.

Equipment needed: Measuring tape, compass, line level, string, GPS

I.B. Determining location of ditches if GIS information is not available

What to measure: Ditches of any size

How to measure: Locate all ditches outside of the Assessment Area (up to 200m) by walking 4 transects north, south, east and west from the edge of the AA. Sketch any ditches on the data sheet in their proper location and record the average depth of each ditch beside the sketch. Distance and Orientation from AA should be determined using a GPS and sketched on map with a protractor. Special attention should be given to ditches approaching the AA. Record the following information on the datasheet by each point:

- Depth of ditch
- Lat/long coordinates from GPS
- Distance from center of AA
- Degrees to center of the wetland (180 reverse from what is on GPS or take compass bearing pointing back to center of AA)

Where to measure: From the center point of the AA to 200m outside of the Assessment Area or 240 from the center of the AA. Take a minimum of 3 measurements at least 25m apart from each other per ditch.

Equipment needed: Measuring tapes, string and line level to measure depth, GPS, and protractor, compass. Since this technique requires a lot of walking in often rough field conditions we recommend that this person and another field crewmember have hand held radios. There are useful to keep in touch if any questions arise or if emergency assistance is needed.

RIVERINE HYDROLOGY DATA SHEET

Stream order: This should be determined from topographic maps. Refer to the site information packet.

I. Inside Assessment Area Stream condition:

What to measure: This is a qualitative measure of impacts on the stream channel

How to measure: Walk the area of stream channel within the assessment area. Look for any signs that the channel is altered or has been altered in the past, i.e. the channel is very straight and of the same width, levees (not natural) present, dams or road crossing present, foot bridges or other minor alterations. Some channelized streams have levees if the spoils are placed next to the stream. If there is a levee present note if it is on the same side of the channel as the Assessment Area. On the data sheet select the box that best describes the condition of the stream.

Where to measure: Within the Assessment Area

Equipment needed: none

II. Outside Assessment Area Stream Condition:

What to measure: This is a qualitative measure of impacts on the stream channel similar to above measurement

How to measure: Walk the area of stream channel outside the Assessment Area and look for any signs that the channel is altered or has been altered in the past, i.e. the channel is very straight and of the same width, levees (not natural) present, dams or road crossing present, foot bridges and other minor alterations. On the data sheet, mark if any fill (i.e. road crossing or dam) is present within the channel and mark the dominant condition of the stream for every 100m section walked both upstream and downstream of the Assessment Area.

Where to measure: 500m from the edge of the Assessment Area upstream and 500m from the edge of the Assessment Area downstream.

Equipment needed: none Note: Since this technique requires a lot of walking in often rough field conditions we recommend that this person and another field crewmember have hand held radios. They are useful to keep in touch if any questions arise or if emergency assistance is needed.

RIVERINE MORPHOLOGY DATASHEET

When to measure: Stream morphology should always be measured within the AA.

What to measure: The cross-sectional dimensions of the stream channel includes

1. Bankfull height in centimeters
2. Top-of-bank height in centimeters

How to measure:

1. At each measuring point identify the bank elevation within 15m of the point – this is the elevation at which water would be able to overflow the bank to flood the wetland.
2. Determine the deepest part of the channel (ie the thalweg) by removing any loose debris from the channel bottom. Use a vertical meter stick or stadia rod to make the following measurements:
 - a. Bankfull height is measured as the distance from the thalweg to the average height of at least two bankfull indicators on the corresponding channel. This is not necessarily where the water level is at the time of sampling. **Bankfull indicators** include
 - i. the height at which short-lived vegetation roots on the bank (excluding vegetation colonizing during periods of drought),
 - ii. lines of erosion near the top of the eroding channel bank,
 - iii. the top of point bars formed on the depositing channel bank,
 - iv. observations of current flow in response to recent precipitation relative to the other parameters.
 - v. At locations where bankfull indicators are poor, nearby indicators can be used as reference.

Care should be taken to determine bankfull height as it is not often obvious and can be misconstrued especially in deeply channelized streams.

- b. For measurements within the AA
 - i. On the AA side of the channel, , attach the string at bankfull height using the line level and string. If the AA is on both sides of the channel attach the string on the side of the channel with the best bankfull indicators. Maintain an accurate cross section through the stream. Attach the other end of the string to meter stick when the bubble in the line level is centered or if assessing both sides the opposite side of the channel when the line is level and record bankfull height.
 - ii. Keep the meter stick or stadia rod in the exact location of the thalweg to measure top-of-bank.
3. Top-of-bank height is the top of the channel measured at the lowest point along channel on the side of the AA (if both sides of the stream channel are included in your assessment area then locate the top of the soil surface on the lowest stream

bank). For measurements outside of the AA always use both sides of the channel and locate the side with the lowest elevation to attach the string.

- a. Raise the opposite end of the string on the meter stick or the other side of the bank until the bubble in the line level is centered and record top of bank height.

Where to measure: In the stream channel

1. Along the longitudinal axis of the AA - measure morphological parameters at 25-m, 50-m, and 75-m with the lowest top of bank elevation. When multiple channels occur, measure the active channel that obviously provides the greatest flow.
2. Outside the AA - take each measurement every 100 meters upstream and downstream of the AA. Measurements outside of the AA should include both sides of the channel.
3. If the channel is a braided stream channel (anastomosing) and the high flow channel cannot be determined note that the floodplain and stream channel are connected.

Equipment Needed: Measuring tapes, compass, line level, string, meter stick

LANDUSE IN BUFFER DATASHEET

Buffer Land Use

- 1.) Examine the newest aerial photos. With a 100 and 200 buffer from the edge of the 40m radius assessment area.
- 2.) Estimate the percent of each landuse type in the 200m and 100m buffers. *Note: The 200m buffer extends from the outer edge of the AA to 200m and includes the 100m buffer.*
- 3.) Estimate the percent of the 100 and 200m buffer that is in each of the listed categories on the datasheet. If “other” is used write in the landuse.

Forested Buffer Types

- 1.) Examine the forested portion of the 200m buffer and determine the various forest types i.e. pine upland, mixed wetland, hardwood wetland etc.
- 2.) Estimate the percent of each type identified of the total forested area
- 3.) Forest habitats that are greater than 10% of the total buffer area must be sampled (see Buffer Overstory Datasheet).

Note: As you walk to each buffer plot note if there are any major differences between current landuse and that of the photo. Update the photo and refine % estimates.

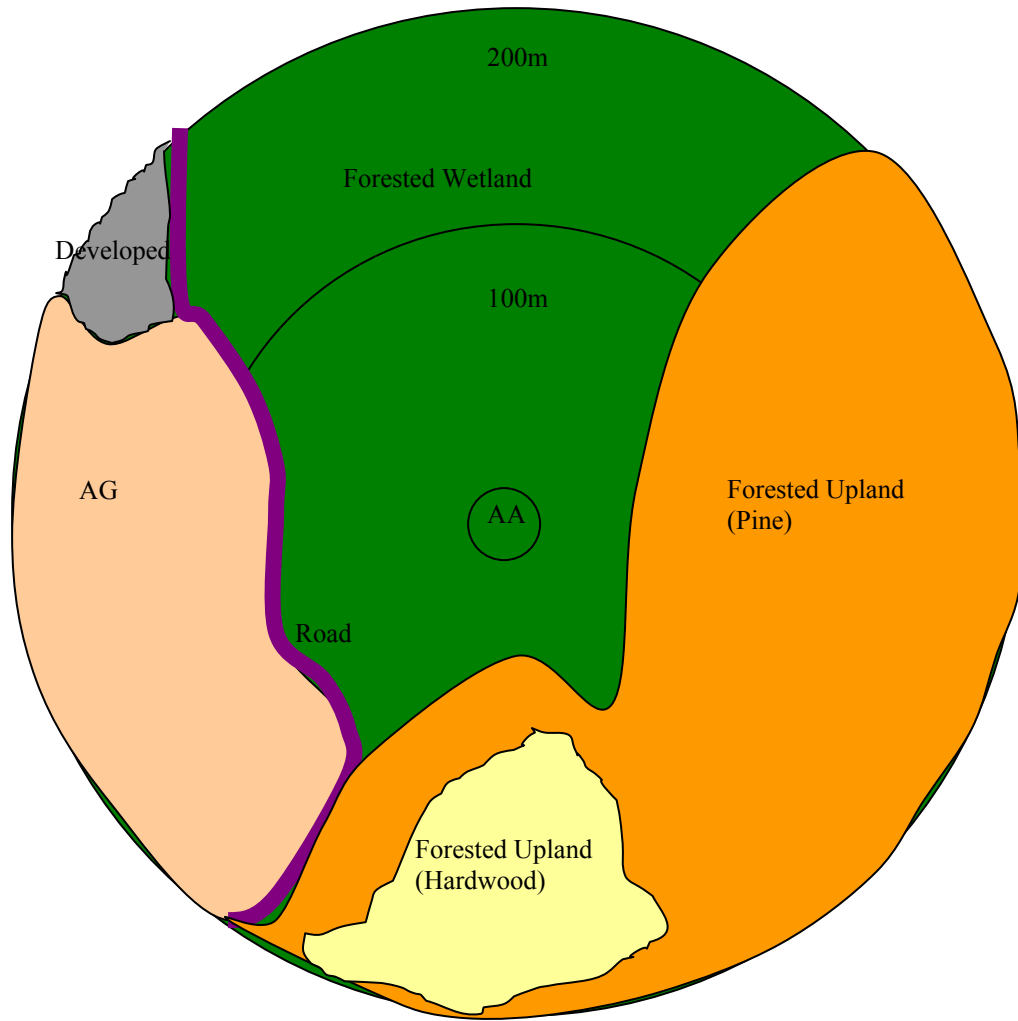

Buffer Landuse			
DE Comprehensive Wetland Assessment v.5.1			
Site # _____	Site Name: _____		
Observers: _____	Date ____/____/____		
Ground truth the Landuse in the 100 & 200 meter buffers			
	200m	100m	
Agriculture (Pasture/Hay/Crops)	22 %	7 %	
Developed (Urban/Res/Roads)	5 %	0 %	
Barren	0 %	0 %	
Other	2 %	4 %	
Forested	71 %	89 %	
	$\Sigma = 100\%$	$\Sigma = 100\%$	
Forest types in 200m buffer			
Forest Type*	Circle One	% of Forested Buffer	Buffer Plot #
Mixed Hardwood	Wetland Upland	60	**
Pine	Wetland Upland	30	1
Mixed Hardwood	Wetland Upland	10	2
	Wetland Upland		
		$\Sigma = 100\%$	
* for each buffer with a different habitat then the AA fill out a buffer basal area datasheet			
** if the buffer is within the same wetland as the AA the buffer plot is randomly selected from vegetation plots			

Figure xx: Estimates of buffer landuse.

BUFFER OVERSTORY DATASHEET

Buffer Plot #: Record the buffer plot where measurements are being taken and the total number of buffer plots that are being sampled

Percent of Forested Buffer: Determine the percent of forested buffer represented by the plot. (Eg. If 40% of the buffer is forested, there may be 2 forest types- one is 25% of the buffer and therefore approx 60% of the forested buffer and the other is 15% of the buffer and therefore approx 40% of the forested buffer). If the forested buffer is the same wetland type as your Assessment Area randomly select a vegetation plot and record all trees greater than 15 cm dbh.

Forest Type: Record the overstory forest vegetation community that the buffer plot is in, i.e. hardwood, coniferous, mixed etc. Circle if the area is wetland or upland.

Distance to Plot (from assessment area): record distance to the buffer plot from the AA point.

Plot direction: record the direction from the AA to the buffer plot

Plot Lat/ long: record the latitude and longitude of the buffer plot in digital degrees

I. Trees

What to measure: All trees that are ≥ 15.0 cm Diameter Breast Height (DBH)

How to measure: Measure the diameter (DBH) of each tree ≥ 15.0 cm in diameter. On the data sheet, record the species and diameter in cm to the nearest tenth, of each individual that is encountered. DBH is measured at 1.28 m from the highest above-ground point of the tree trunk. If branches or bulges occur on the tree trunk the DBH should be recorded immediately below the branches or bulges. If trees have vines attached to the trunks at the point of the DBH measurement, attempt to pull the vine away so that you only measure the tree trunk. For trees with multiple trunk stems, stems are counted as individual trees if they split lower than 1.28 m from the ground. If a tree has more than one trunk stem but the split is over 1.28 m from the ground, only measure the main trunk at 1.28 m. After measuring a tree, place a small mark with chalk to avoid measuring any trees twice.

Where to measure: Measure in buffer plots which are located according to the protocols listed above. Buffer plots are 8.92m radius (17.84 m diameter) circular plots (0.025ha). Trees on the edge of the circular plot should be checked for their inclusion within the plot by running an 8.92-meter tape directly to the center of the tree from the center of the buffer plot. If the center of the tree is outside the plot the tree is not recorded.

Equipment needed: DBH tapes, (3) 30-m measuring tapes, chalk.

SITE INFORMATION DATA SHEET

Crew Leader Initials: Initials of the Crew Leader present during sampling

HGM Subclass: HGM subclass of wetland according to definitions and key above

Reference or Assessment Site: circle which applies. Reference sites are subjectively selected because they represent a specific condition such as minimally disturbed or impacted by a specific stressor or represent an ecological variation of a wetland class. Reference sites do not have to be pristine or minimally disturbed. Assessment sites are sites that have been randomly selected using a probabilistic sampling design.

Natural, re-establishment, establishment, enhancement (circle one): Select the appropriate choice based on the definitions provided above. If the wetland is any category other than natural a DE Restoration Info sheet should also be filled out in addition to all of the standard dataforms with this method.

Watershed: record the watershed that the site is located in, if this is unknown it can be determined by overlaying the DE watershed layer of the lat/long that is taken on site.

Lat/Long: Latitude and longitude coordinates in digital degrees

Photos: The frames that are shot should be marked on the data sheet. If more than two are taken, the range can be given

Wetland Size: record the size of the wetland in hectares, this information can be obtained from the NWI or state wetland maps for natural wetlands or construction records for restored or created sites.

AA moved from original location? Circle yes or no to indicate if the center of the AA was moved from its original location. This only applies to assessment sites that are based on randomly located AA. If the center was moved record reason that the AA was moved.

I.A. Wetland Vegetation Zones Present

What to measure: Percent cover of the AA of all vegetation zones present in the original AA (if the site wasn't split) or in the subsite that is being assessed on the site information datasheet (if the site was split).

How to measure: Walk the assessment area and observe different vegetation zones (communities) that are present (provide details- walk perimeter and cross-hatch AA).

In the space provided, estimate the percent cover of the assessment area for all the vegetation zones that are present in the AA or subsite that is being assessed. If a

zone is present that is not listed, use the other box and write in a description of the zone. If a zone is not present record a “0”. In the space provided record all the vegetation zones sampled.

Where to sample: In the assessment area (AA)

Equipment needed: none

I.B. Vegetation Disturbance

What to measure: This is a qualitative measurement that uses observation of the site to determine past anthropogenic disturbance to the vegetation.

How to measure: After all data has been collected this variable is discussed as a group. Discuss all observations made within the Assessment Area including cut stumps and their state of decay, any tree cores that were taken, and the presence of any reoccurring vegetation disturbance such as mowed levees. Do not consider impacts from Gypsy Moth and Pine Bark Beetle in this category but make notes of such impacts in the comments section. From everyone’s observations determine the age of the disturbance to the site.

Continual or periodic disturbance – this refers to an activity within the AA that would not allow the regeneration of native vegetation on the site, i.e. a mowed area along a ditch or powerline right of way that is preventing succession from occurring, or a permanent alteration to the habitat such as a road that would prevent the area from becoming vegetated.

Detailed notes on observations of disturbance and the current condition of the site should be made in the comments sections of the datasheet.

An estimate of stand age should be determined from a tree core.

Technique for taking a tree core:

Definition: A tree core sample is a cylindrical cross-section of tree from the core to the bark, bearing growth lines which can be counted to determine the age of the tree.

Procedure: A tree core sample should be taken from the trunk of a tree of a dominant species within the Assessment Area. The sampled tree should represent the average diameter at breast height (DBH) or average age of overstory canopy trees within the Assessment Area. The core should be extracted from breast height (1.28 meters) and should extend halfway through the width of the trunk at a regular point, i.e., without branches or bulges. The increment borer should be removed from tree immediately after the core has been removed to prevent the tree from closing around the borer. Growth rings on the core should be counted under direct sunlight in the field if possible or with dye or sanding later to determine

the age of the tree. Indicate whether the tree core was counted in the field or collected to be counted later. Add three years to the age determined to account for the growth to the height where the core was taken.

1. Determine if the site has been converted to a pine plantation and circle the correct response.
2. If assessment area is affected by a continual disturbance such as mowing, plowing etc. record if either >50% of AA is impacted or <50% of AA

Where to sample: In Assessment Area

Equipment needed: Increment borer

II. Microtopography Disturbance

What to measure: This is a qualitative variable and should be discussed as a group at the completion of sampling. Check any of the features that were present within the Assessment Area.

How to measure: Walk around Assessment Area and look for signs of windrows (a row of debris pushed to the side), roads (any type of road including constructed, paved, or logging roads, skidder tracks (tracks made by a tractor from hauling logs), plowing, grading (ground leveled off to a smooth horizontal or sloping surface), bedding or other disturbances that would alter the microtopography. If site is restored or created observe if microtopography was restored to the site in the form of hummocks (hills) and hollows (islands do not count toward microtopography) and check this box if appropriate. If plowing, bedding, or grading are present in the AA, estimate if they are affecting > or < 10% of the AA and mark the appropriate line.

Where to sample: In Assessment Area

Equipment needed: None

III. Fill

What to measure: This is a qualitative variable and should be discussed as a group at the completion of sampling. Observations should be made on the amount of fill that is present within the Assessment Area. Estimate the percent of the AA that fill is covering. Fill is defined as any soil, debris, garbage (including large appliances), or excavated material placed in the Assessment Area; this includes ditch spoil. Bedding is not included as fill, however, windrows should be included as fill.

How to measure: Walk around the AA and note any areas that are covered with fill. Estimate the percent of the AA that fill is covering.

Where to sample: In the assessment area

Equipment needed: none

IV. Natural Hydrology Sources for Depressions Only

What to measure: Observations should be made on site to determine if there is an inlet or outlet present to the wetland (the inlet or outlet do not have to be in the assessment area to be counted). Inlet and outlets are areas that where concentrated surface water flows into or out of the depression. If both an inlet and outlet are present then flowthrough should be marked.

V. Hydrologic Disturbance

a. Riverine: Floodplain Condition

What to measure: This is a qualitative variable and should be discussed as a group at the completion of sampling. Observations should be made on alterations to the hydrology of the floodplain within the Assessment Area. This variable is only assessed for riverine wetlands.

The presence of indicators of overbank flooding should be noted and recorded as present (yes) or absent (no). Signs that overbank flooding is occurring include rack lines, debris and watermarks.

How to measure: Walk the AA and estimate the percent of the AA that is impacted either by being covered with fill or by being impounded with water due to a dam or culvert. Also note the presence of any ditches on the floodplain. Fill is defined as any soil, debris, garbage, or excavated material placed in the Assessment Area; this includes ditch spoil. Check the appropriate line for the condition that is present in the floodplain.

Where to sample: In the assessment area

Equipment needed: none

b. Non-Riverine: Hydrologic Modifications to Site

What to measure: This is a qualitative variable and should be discussed as a group at the completion of sampling. Observations should be made on alterations to the hydrology of the wetland within the Assessment Area.

How to measure: Walk the AA and observe any impacts that may be altering the hydrology within the AA such as ditches, control structures, roads, etc. Additionally determine if the site has an inlet and an outlet. If ditches are found within the AA area determine if possible if the ditch is conveying water to the site or out of the site. Also determine if any of the site was excavated (borrow pits or ponds). If site is a restoration site do not check excavation if the intent was to restore the natural hydrology of the site but check the line for hydrology restored to site.

Check the appropriate line(s) for the condition(s) that is (are) present.

Where to sample: In the assessment area

Equipment needed: none

Qualitative Condition Rating: The Qualitative Condition Rating assumes that condition declines with increased human disturbance. Through observation of vegetation, soils, hydrology and disturbance wetland assessors determine the degree of impact a disturbance has on a site. This is based on the Tier Aquatic Life Use Conceptual Model (Appendix G).

Method:

Rate the condition of the wetland (and surrounding buffer) from least disturbed (1) to highly disturbed (6) relative to other sites in the watershed based on best professional judgment (BPJ) (Figure 4). General description of the minimal disturbance, moderate disturbance and high disturbance categories are provided below. Observers should then use BPJ to assign a numerical Qualitative Condition Rating (QCR) within each disturbance category.

- **Minimal Disturbance Category (QCR 1 or 2):** Natural structure and biotic community maintained with only minimal alterations. *High condition sites have a mature vegetative community, intact wetland soils and a natural hydrologic regime. These sites have natural water flow into and out of the site, undisturbed microtopographic relief, and are located in a landscape of natural vegetation (200m buffer).* Examples of minimal alterations include small ditch that is not conveying water, low occurrence of non native species, targeting cutting of a single tree, and small areas of altered habitat in the surrounding landscape. Use BPJ to assign a QCR of 1 or 2.
- **Moderate Disturbance Category (QCR 3 or 4):** Moderate changes in structure and/or the biotic community. *Medium condition sites maintain some components of high condition sites such as intact hydrology, undisturbed soils and microtopography, intact landscape, or mature biotic community despite some structural or biotic alterations.* Structural alterations include a large ditch or dam either increasing or decreasing flooding, moderate stream channelization, mowing, grazing, presence of invasives, forest harvesting, high impact landuses in the buffer. Use BPJ to assign a QCR of 3 or 4.
- **High Disturbance Category (QCR 5 or 6):** Severe changes in structure and/or the biotic community. *Low condition sites have severe alterations to the vegetative community, hydrology and soils. This can be a result of one severe alteration or multiple moderate alterations. These disturbances lead to a decline in the wetland's ability to effectively function in the landscape.* Examples of severe alterations include extensive ditching or stream channelization, recent clear cutting or conversion

to a non-native vegetative community, and roads, fill, excavation or farming in the wetland. Use BPJ to assign a QCR of 5 or 6.

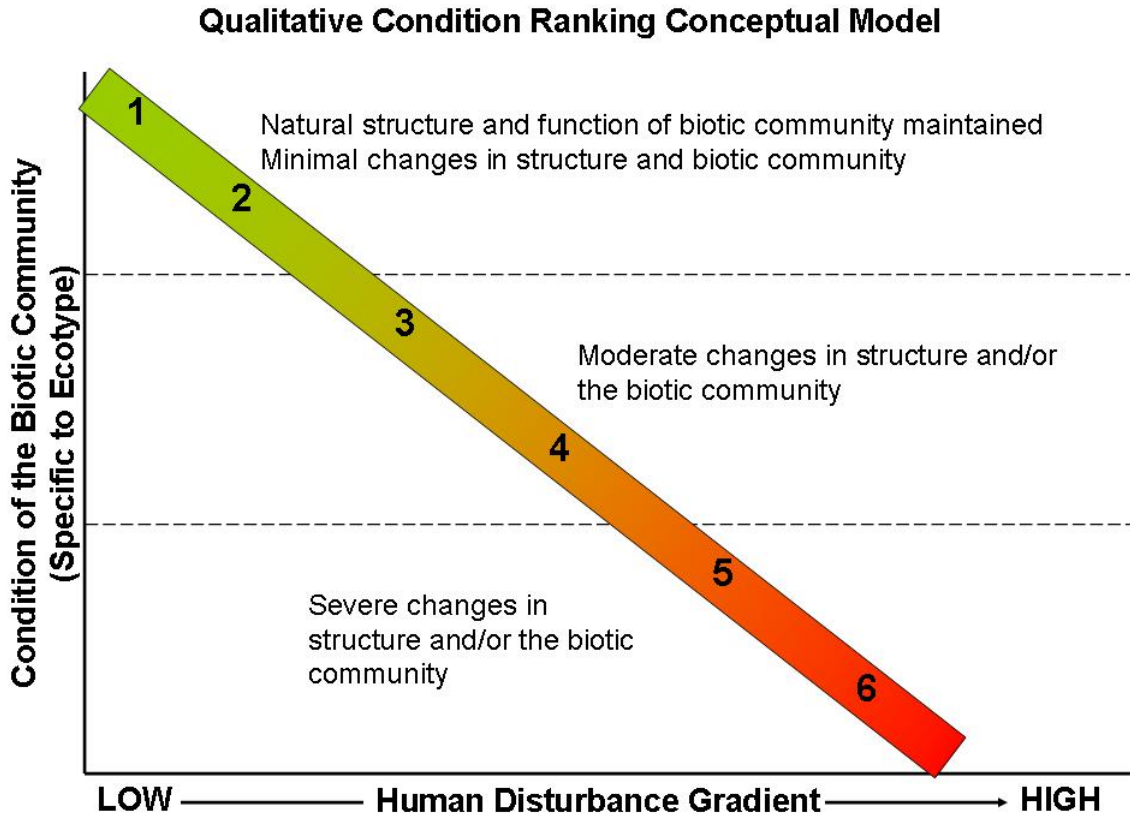

Figure 4. Diagram of narrative criteria for qualitative ranking of condition

VII. Sketch of Site

Draw a sketch of the site, important attributes to include are different vegetation communities including the placement of vegetation plots within each community, roads in or adjacent to the AA, other large alterations such as dams, and forestry activities in part of site. Also include an arrow indicating North.

APPENDIX A - DELAWARE RESTORED/ CREATED SITE INFORMATION DATASHEET

Site Name: Names are given to each site

Site #: Unique number for site

Restored/ Created/ Unknown: Check the appropriate box for if the site was restored (constructed in an area with hydric soils), created (constructed in an upland), or the origin is unknown

Information Source: the person or agency that provided the information on the site. *If there was no source and the information on this datasheet was determined by site observation then record "none – site visit"*

Date: Month, day and year of sampling

Observer: Person recording the information

Photos: The frames that are shot should be marked on the data sheet. If more than two are taken, the range can be given

Landowner Information

Name: name of the person or company/ agency that owns the property

Address (street, city, state, and zip): address of the landowner

Phone Number: phone number of the landowner

Potential for access: Yes/ no if you or the source thinks that we would be able to have access to sample the site

Site Information

Lat/long: latitude and longitude of the center of the site, this can be obtained using a handheld GPS unit

Wetland size: size of the wetland in hectares

Date of construction: month and year that construction was completed

Watershed: major watershed that the wetland is part of i.e. Choptank, Nanticoke, Inland Bays

County, State: county and state that the wetland is located

Public property: Check this box if the wetland is on public property

Easement term: the number of years that the site is under a conservation easement

End date: the year that the easement expires if the site is under a conservation easement

Directions to site: road directions to the site from a known landmark

Restoration Type

See federal definitions

Habitat Type (check if any of the below are present on site; provide actual or estimated area in hectares)

Upland: wildflower meadow, open space, urban garden, warm season grass meadow, shrub, or forest

Wetland: tidal or non-tidal

Invasive species: if site is dominated by invasive species

Buffer: choose cover (grass or forest) and target (stream/ditch or wetland)

Selective thinning: evidence of forest management practices

Stream: record linear area in feet if present

Construction Organization

Lead group: lead group in charge of the project

Contact name: contact name with the lead group

Phone number: phone number of the lead group

Cooperating groups: groups or organizations that were cooperating with the lead group to restore/ construct the wetland

Conservation program: name of conservation programs that the wetland is a part

Funding sources: name of funding sources used to construct the wetland

Construction Techniques (check the box if any of the below are present on site)

Inlet: confined area where water is moving into the site

Outlet: confined area where water is moving out of the site

Closed basin: no inlet or outlet present

Ditch plug: flow through a ditch has been restricted by filling or damming the ditch

Microtopography:

Islands/ macrotopography: presence of islands or macrotopography in the wetlands, examples include nesting islands or large areas of upland within the wetland

Excavation: soil was removed to lower the elevation of the wetland

Control structure (boards/ pipes): presence of a structure that regulates the depth of water in the wetland (mark if the structure uses either boards or pipes)

Burning:

Log toe protection:

Rock toe protection:

Cross vanes:

Log vanes:

Rock vanes:

Root wads:

J-hooks:

Irregularity of edge: this should be rated as high, medium or low using the following as examples

Low irregularity Medium irregularity High irregularity

Other: list any other construction techniques that were used

Long-term goal: record the type of site that was intended to be created or what was the long term-goal of the site (i.e. open water impoundment, forested wetland, scrub/shrub wetland)

Construction Amenities: check all the boxes of amenities that were applied to the wetland

Top soil: soil that was removed from the site before construction or additional soils that were brought in from off site

Horse bedding: bedding from horse stables

Wood chips:

Straw/hay:

Corn silage: Silage is moist forage, stored in the absence of air and preserved by acids produced during ensiling

Coarse woody debris: logs or stumps of trees

Biologs:

Coconut mats:

Rip rap:

Liners:

Native plantings:

Live branch layering:

Herbicide control: herbicide applied for cattails or *Phragmites*, record the last year that it was applied

Other: other amenities that were added to the site

Planted (nursery stock, relocations, seeded): check if the site was planted with nursery stock, relocations, transplants, or seeded. Record the species that were planted in the box below

Hydrology

% permanent water: estimate the percent of the wetland that is covered by permanent water (water that remains the entire year under a normal precipitation year)

% open water @ full capacity: estimate the percent of the wetland that is covered by open water when the water level is at full capacity for the wetland. Open water is areas that do not have persistent vegetation such as trees, shrubs, cattails, bulrushes or other species that protrude above the surface of the water at full capacity. Areas that have water lilies or submerged vegetation would be included in the open water estimate.

Primary Water Source: check the box for the source of hydrology to the wetland as either precipitation or groundwater.

Secondary water source: list any additional sources of water that are contributing to the hydrology of the site

Invasive Species Management

Wet glove:

Backpack sprayer:

Mechanical:

Drip:

Biological control:

Injection:

Cut stump:

Burn:

Invasive Species

% cattail: estimate the percent of the wetland that is covered by cattail species

% Phragmites: estimate the percent of the wetland that is covered by *Phragmites*

Buffer

Buffer width (range): record the range of the width of buffer surrounding the site. Any cover types that are not actively managed or disturbed on a yearly basis or less are considered as buffer.

Examples of buffer cover types:

Old field

CRP plantings of grass buffers or warm season grasses

Forest

Other wetlands

Examples of cover types that are not considered buffer:

Agriculture

Roads

Residential areas or lawns

Urban or industrial areas

Mowed grass

Surrounding land use cover types: estimate the percent of the surrounding land uses within approximately 100m of the wetland edge. The total estimates should equal 100

Comments

APPENDIX B. CLASSIFICATION OF DELAWARE'S WETLANDS USING HYDROGEOMORPHIC ATTRIBUTES AND DESCRIPTIVE EXAMPLES

HYDROGEOMORPHIC CLASS ² Subclass	Dominant water sources of class and flow dynamics	Major source of variation within subclass	NWI vegetation classes ³	Regional example	Citation
FLAT	Precipitation; Vertical fluctuation				
Mineral soil		Hydroperiod and fire frequency	FO, SS, EM	Wet pine flatwoods/ pine savannas: Broad areas with poor drainage on mineral soils	Walker and Peet (1983); Rheinhardt et al. (2002); Rheinhardt and Rheinhardt (2000)
Organic soil		Peat depths (from histic epipedons to histosols)	FO, SS, EM	Southern peat bogs such as pocosins: Broad areas with poor drainage that accrete organic matter	Richardson (1981)
SLOPE	Groundwater discharge and interflow; Unidirectional & horizontal				
Mineral soil		None available	FO, SS, EM	Spring seep	Cole et al. 1997
Organic soil		None available	FO, SS, EM	Forested fen	WPC 1998
Sea-level fen	Groundwater seepage, oligotrophic, acidic freshwater		EM		

²Upper case in bold are HGM classes; lower case in bold are regional subclasses, except for deepwater environments.

³ NWI vegetation classes: forested (FO), scrub-shrub (SS), emergent (EM), aquatic bed (AB), unconsolidated shore (US), unconsolidated bottom (UB), riverine (R), Lacustrine (L), estuarine (E), marine (M).

DEPRESSION	Precipitation or groundwater; vertical fluctuation				
Inland	With or without inlet and outlets		FO, SS, EM,	Coastal plain ponds, forested depressions	
Interdunal Swale	Groundwater driven	Groundwater withdrawal causing intrusion of salt water, ditching, dune crossings, OMWM, invasive species	PEM	Along Atlantic coastal strand and barrier islands, shallow depressions behind primary dune ridges	DENHP (1994)
Human impounded or excavated		Size of catchment	SS, EM, AB	Borrow pits; some farm ponds; some created wetlands	xxxx

RIVERINE – non-tidal	Overbank flow from channel and groundwater discharge; Unidirectional				
Intermittent-Upper perennial	Non-tidal	Range of hydroperiods within riparian zone (usually < third order), gradient high, water velocities fast.	FO, SS, EM, AB	Riparian forest	Rheinhardt et al. (1998); Rheinhardt et al. (2000)
Lower Perennial	Non-tidal	Range of hydroperiods within 100-y floodplain, including in-stream terraces and bars (usually > third order) Gradient is typically low; water velocities slow.	FO, SS, EM, AB	Bottomland or floodplain forest	NRC (2002)
Beaver-impounded		Dam more temporary than human-impounded; usually < third order	FO, SS, EM, AB	Beaver pond	Klotz (1998) Bason and Brinson (in preparation)
Human-impounded⁴		Range of water residence times based on impoundment volume and discharge	FO, SS, EM, AB	Mill ponds; large farm ponds not deemed to be Depression	xxxx

ESTUARINE TIDAL FRINGE	Mixture of sea and fresh water; bi-directional and horizontal					
Estuarine lunar intertidal						
	Freshwater tidal (ETF)		FO, EM, AB	Freshwater tidal swamps		
	Brackish tidal (ETB)	Meso-polyhaline (>5 ppt) Oligohaline (.5 – 5ppt)	EM, AB	<i>Spartina alterniflora</i> -dominated zone <i>Nuphar advena, Zizania aquatica</i> dominated		Stevenson et al. (1977) Simpson et al. (1983); Rheinhardt (1992)
Estuarine subtidal		Low energy regime allows SAV establishment (Salinity ranges - 0 to >30ppt)	FO	Mud and sand flats; SAV beds; Oyster reefs		Rybicki et al. (2001) Southworth and Mann (2004)
Estuarine impounded		Flow is blocked by dike, gate, or dam; water source precipitation except for controlled delivery of estuarine water of varying salinity	FO, EM, AB	Waterfowl impoundments?		xxxx
Marine tidal fringe	Marine source; bi-directional and horizontal					
Marine intertidal		N/A	US	High energy beach		
Marine subtidal		N/A	UB	Shallow littoral		

APPENDIX C - DELAWARE INVASIVE SPECIES LIST

excerpt from *The Flora of Delaware* W.A. McAvoy, 6-23-2008

- Acer platanoides* Norway maple
Acorus calamus European sweetflag
Ailanthus altissima tree-of-Heaven
Akebia quinata five-leaf akebia
Alliaria petiolata garlic mustard
Allium vineale field garlic
Ampelopsis brevipedunculata porcelain-berry
Aralia elata Japanese angelica-tree
Arthraxon hispidus joint-head arthraxon
Azolla caroliniana eastern mosquito-fern
Berberis thunbergii Japanese barberry
Bidens polylepis awnless beggar-ticks
Cabomba caroliniana Carolina fanwort
Cardamine impatiens touch-me-not bittercress
Carex arenaria sand sedge
Carex kobomugi Japanese sand sedge
Celastrus orbiculata Oriental bittersweet knotweed
- Centaurea stoebe subsp. micranthos* spotted knapweed
Cirsium arvense Canada thistle
Clematis terniflora Japanese virgin's-bower
Conium maculatum poison-hemlock
Convolvulus arvensis field bindweed
Cynanchum louiseae black swallow-wort
Dactylis glomerata orchard grass
Echinochloa crus-galli barnyard grass
Egeria densa Brazilian waterweed
Eichhornia crassipes water hyacinth
Elaeagnus umbellata autumn olive
Eragrostis curvula weeping lovegrass
Euonymus alatus winged euonymus
Fallopia japonica/ Polygonum cuspidatum
Japanese knotweed
Ficaria verna/Ranunculus ficaria lesser celandine
Frangula alnus/Thramnus frangula
European alder-buckthorn
Galanthus nivalis snowdrops
Hedera helix English ivy
Hemerocallis fulva orange daylily
Hordeum jubatum foxtail barley
Humulus japonicus Japanese hops
Hydrilla verticillata hydrilla
Iris pseudacorus yellow iris
Lespedeza bicolor shrubby bushclover
Lespedeza cuneata Chinese bushclover
Leucjum aestivum summer snowflake
- Ligustrum obtusifolium* border privet
Ligustrum vulgare European privet
Lonicera japonica Japanese honeysuckle
Lonicera maackii Amur honeysuckle
Lonicera morrowii Morrow's honeysuckle
Lonicera tatarica Tartarian honeysuckle
Ludwigia leptocarpa water-willow
Ludwigia peploides subsp. glabrescens floating seedbox
Lythrum salicaria purple loosestrife
Microstegium vimineum Japanese stilt grass
Murdannia keisak marsh dewflower
Myriophyllum aquaticum parrot's-feather
Myriophyllum spicatum Eurasian water-milfoil
Pachysandra terminalis pachysandra
Perilla frutescens beefsteak plant
Persicaria longiseta/Polygonum cespitosum longbristle
Persicaria perfoliata/Polygonum perfoliatum mile-a-minute
Phalaris arundinacea reed canary grass
Phragmites australis subsp. australis common reed
Phyllostachys aurea bamboo
Pinus thunbergiana Japanese black pine
Poa trivialis rough bluegrass
Populus alba white poplar
Pueraria montana var. lobata kudzu
Pyrus calleryana Callery pear
Rhamnus cathartica buckthorn
Rhodotypos scandens jetbead
Rosa multiflora multiflora rose
Rosa rugosa rugosa rose
Rubus idaeus subsp. strigosus red raspberry
Rubus phoenicolasius wineberry
Schedonorus pratensis/Festuca pratensis meadow fescue
Schoenoplectus mucronatus/Scirpus mucronatus alien bulrush
Sorghum halepense Johnson grass
Stellaria media common starwort
Symphoricarpos albus white coral-berry
Symphoricarpos orbiculatus coral-berry
Typha angustifolia narrowleaf cattail
Urtica dioica subsp. dioica stinging nettle
Viburnum sieboldii Siebold's viburnum
Vinca minor lesser periwinkle
Wisteria floribunda Japanese wisteria
Wisteria sinensis Chinese wisteria
Xanthium strumarium rough cocklebur

APPENDIX D - DELAWARE WETLAND MONITORING PROGRAM LANDSCAPE ANALYSIS PROTOCOLS

Updated March 17, 2006

INTRODUCTION

1. The most recent available data should be used for new analyses.
2. Links to metadata should be provided when available including any changes from the original data. The indication of manual reprojection should be indicated.
3. A brief description of all layers used to generate data should be provided for variable sheets and reports.
4. Quality Assurance Quality Control (QAQC) exercises will be conducted when multiple users are processing data following the QAQC guidelines below:

The Project Leader will check for accuracy of the data using the rule that the data cannot differ by more than 10% between processors. Measurements compiled by the Project Leader will represent the standard against which results of other team members are compared. When the variability is greater than 10%, the crewmembers will discuss the sampling protocols with the Project Leader and the measurement procedure will be repeated until the degree of accuracy is within acceptable limits. Project Leader will keep records from the checking activities.

FILE NAMING CONVENTION

Name buffer and landuse files using these conventions with abbreviations:

1. watershed_subclass_reference type_year_buffer type_bufferwidth (e.g. na_fla_ass_99_buff_40m).
2. watershed_subclass_reference type_year_landuse_bufferwidth (e.g. na_fla_ass_99_lu_200m).
3. watershed_subclass_reference type_year_impervious-coverage_bufferwidth (e.g. ib_riv_ref_99_imp_1000m).
4. watershed_subclass_reference type_year_canopy_bufferwidth (e.g. na_fla_ass_99_cnp_1000m).

LANDUSE/IMPERVIOUS SURFACE COVERAGE

1. Add a point file of sites into ArcMap that has meters for map units and distance units – DE state plane NAD 83.
2. If the Buffer Theme Builder Extension `Buf_w_v2.zip` is not loaded into ArcMap, do so; it can be downloaded from www.esri.com.
3. Use the Buffer Theme Builder Extension to create 40 m radius AAs polygons for the points. Use meters for the distance and point for the buffer type. It can never hurt to keep the site point fields with the new buffers. At least the site number and site reference type must be included. *The AA of irregularly shaped sites should be added to the buffer sites as created polygons.*
4. Use the Buffer Theme Builder Extension to create 200 m radius buffers of the 40 m radius AAs and irregularly shaped AAs. Choose the Inside/Outside option for buffer type. This creates donut polygons that do not include the AA.
5. Use the Buffer Theme Builder Extension to create 800 m radius buffers of the 200 m radius AA for the points as above. *Analyses occur within the 200-m AA buffers and the buffers that are 200 – 1000 m from the AA.*
6. In ArcMap add landuse layers for analysis (eg NLCD2001) and the 200 and 800 m radius buffers.
7. Select the Identity function in the ArcToolbox – Analysis Tools – Overlay. Use the buffers as the input and the landuse layer as the identity layer. Run the function on the 200 and 800 m buffers for all appropriate landuse layers.
8. Use Hawth's Tools for ArcGIS to calculate the area of different landuse squares within the buffers. Hawth's Tools can be downloaded from the web <http://www.spatial ecology.com/>. Add the toolbar to your view. Select Analysis Tools – Table Tools – Add area/perimeter. Just add the area; values will be in square meters. *The attribute table must be closed for this to work.* Check that the area landuses in a site adds up to the total area of the buffer that is produced with the buffer wizard.
9. Export the tables to a file as dBase format.
10. Open the files using Excel...

FOR NLCD/LUCL

11. In Excel, add the data from the 800 m buffers to the data from the 200 meter buffers so that fields align correctly. *Note: the area of the 40-m radius AA generated with the GIS is 5,027 m², the area of the 200-m buffer of the 40-m radius AA generated with the GIS is 175,124 m². These are slightly off the actual geometric areas.*
12. Highlight only the gridcode column and use replace to change all gridcodes to their respective landcovers. The full list with descriptions can be found in the metadata of the NLCD01 or in Homer et al. (2004). A partial list can be found in the table below.
13. Create a pivottable in Excel that has buffer width and site type (i.e. testing vs. assessment sites) as page, site in the row, gridcode or landuse in the column and area set to % of total in the data section. This provides a table of % landuse by site.
14. Sum the percentages to create % developed and % high impact landuse (see Vbuffuse200 variable sheet).
15. Sites that have Open Water in their buffer must be examined to determine if the open water is a natural feature or high impact landuse. Open water features that qualify as high-impact landuse include, but are not limited to, storm water detention ponds, borrow pits, golf course water features, agricultural and municipal waste lagoons and residential development water features not necessarily used as storm water ponds. Natural open water includes estuaries, mill ponds, rivers, and open water depressional wetlands. Sites with high impact open water features should be analyzed separately with respect to step # 14 above.

16.

Select NLCD 2001 Land Cover Class Descriptions (Homer et al. 2004)

Gridcode	Landcover
11	Open Water
21	Developed, Open Space
22	Developed, Low Intensity
23	Developed, Medium Intensity
24	Developed, High Intensity
31	Barren Land
32	Unconsolidated Shore
41	Deciduous Forest
42	Evergreen Forest
43	Mixed Forest
52	Shrub/Scrub
81	Pasture/Hay
82	Cultivated Crops
90	Woody Wetlands
95	Emergent Herbaceous Wetlands

FOR IMPERVIOUS SURFACE

11. In Excel put the data from the 200 m and 800 m buffers in separate worksheets eliminating the unnecessary fields.
12. Add a column for % Imperviousness by total site (buffer).
13. Convert the Gridcode for canopy density/imperviousness by polygon within the buffer to a proportion (gridcode * 0.01).
14. Sort by site type (testing v assessment) if necessary, then by site.
15. Use the SUMPRODUCT function to create a weighted average of imperviousness for each buffer. (i.e. =SUMPRODUCT(D19:D42,E19:E42)/(SUM(E19:E42)) where column D is the proportion imperviousness for a polygon and column E is the corresponding polygon area).
16. Copy and paste special – values the % imperviousness for each buffer column.
17. Sort by the above column then copy and paste the results into a table.

DISTANCE TO NEAREST ROAD

1. Load wetland assessment area features and the most recent available aerial photos into a GIS.
2. Use the measure tool to calculate the distance from the edge of the assessment area as defined by the shapefile boundary to the closest edge of nearest road. Roads are defined as paved and non-paved roads that may include maintained logging roads and long access driveways (> 150 m), or horse tracks, but do not include unmaintained logging roads, standard residential driveways, tax ditch access roads, or paths and trails. Measure the length of long access driveways in the buffer when a portion of or the entire driveway occurs in the buffer.

BUFFER ROAD DENSITY

1. Load the appropriate buffer features, USGS topographic raster features, road layers, and DOQQs into a GIS.
2. Measure the length of each road segment within the buffer making sure to exclude and length within the AA or an inner buffer. Roads are defined as paved and non-paved roads that may include maintained logging roads, long access driveways (> 150 m), or horse tracks, but do not include unmaintained logging roads, standard residential driveways, tax ditch access roads, or paths and trails. Measure the length of long access driveways in the buffer when a portion of or the entire driveway occurs in the buffer. As each road segment is measured mentally assign a class to the road and record the width using the table below.

Table 1. Width of roads by type for Buffer Road Density Analysis. Widths derived from (Tiner 2004) except for the last 3 types, which were derived from field experience and GIS measurements.

Road Type	Width (m)
Interstate highways (per direction)	12.1
State roads	12.1
County and local roads	11.5
Dirt roads (two lanes) and large logging roads	6.7
Small logging roads (essentially one lane)	4.5
Long access driveways (> 150 m) (may be residential commercial or industrial)	4.5
Railroads	7.9

3. **Tips for identifying road classes:** a) state roads can often be distinguished from county and local roads through different coloration and labeling on topographic maps or Gazateers, b) certain large, well-maintained logging roads should be classified as dirt roads.
4. **How to deal with large areas of impervious surface.** For roads entering large lots, continue the length of the road to the end of the lot on the same direction the road entered the lot.
5. **Cul-de-sacs.** The loop of typical Cul-de-sacs should not be measured. Instead measure the length of the road to the end of the cul-de-sac. Horse race tracks are not counted as roads.
6. Multiply each road segment length by its width and sum the total area, then divide by the total area of the buffer, then multiple by 100 to get the percent of the buffer covered by roads.

REFERENCES

Homer, C., C. Huang, L. Yang, B. Wylie, and M. Coan. 2004. Development of a 2001 National Land-Cover Database for the United States. *Photogrammetric Engineering & Remote Sensing* **70**:829-840.

Tiner, R. W. 2004. Remotely-sensed indicators for monitoring the general condition of "natural habitat" in watersheds: an application for Delaware's Nanticoke River watershed. *Ecological Indicators* **4**:227.

APPENDIX E - GENERATING RANDOM BUFFER PLOTS

- (1) Required layers (general):
 - a. Assessment buffers
 - b. "swmp" layer without uplands
- (2) Zoom to the site of interest and, using the "select tool" (arrow with highlighted polygon), select the 100 and 200 meter buffers for the site (hold down the shift key to select both)
- (3) Click on Hawth's Tools/Sampling Tools/Generate Random Points (To add Hawth's Tools in ArcMap, click on "Tools/Customize" and check its box – it should be installed on all computers with GIS, but if not <http://www.spatial ecology.com/>)
 - a. Select reference layer from the pull-down menu: Buffers
 - b. Check: "Use selected features only"
 - c. Check: "Enforce minimum distance between points" and type 20
- (4) Under "Unstratified sampling design," type the number of points you want generated (10 is sufficient, but more may be required depending on the complexity of the site)
- (5) Under "Output," choose the folder you want to save the output file to and name it
- (6) Click "OK"
- (7) Once the random points are generated, their ID and X,Y coordinates need to be added to the attribute table
- (8) To add an ID to each point
 - a. Click on "Editor/Start Editing" (toolbar)
 - b. Choose the folder where the new point layer is located, click "OK"
 - c. Open the attribute table of the new point layer
 - d. Under Id, type a number for each point (e.g. 1,2,...)
 - e. Stop editing, save edits
 - f. Label features of the point file so numbers are displayed
- (9) Select points based on forest type and disturbance history (1 point for each – will be field checked)
 - a. In their order (Id #) select the first point that falls within each forest type that is greater than 10% of the buffer
 - b. Different forest types that require buffer plots include forested wetlands, forested uplands, pine dominated, hardwood dominated, and/or obvious difference in age or structure (*refer to aerial photography*).
 - c. Additionally, if the assessment site is located within a large wetland that makes up >10% of the buffer, randomly select a vegetation plot that was or will be sampled as part of the DECAP and use this data to characterize the buffer for the cover type (record which veg. plot will be used before going into field)
- (10) Change the data frame's coordinate system
 - a. Double click on "Layers" (at the top of the table of contents)
 - b. Click on the "Coordinate System" tab
 - c. Click "Predefined/Geographic Coordinate Systems/World/WGS 1984"
 - d. Click "OK", then "Yes"
 - e. The layers will appear distorted, but that's normal (you're now seeing the layers displayed on a sphere rather than a plane)
- (10) Click on Hawth's Tools/Table Tools/Add X,Y to Table (points)
 - a. Select the new point layer from the drop-down menu
 - b. Under "Add new fields" name the X and Y fields ("X" and "Y" will work fine)
 - c. Under "Projection" select "Use the same Coordinate System as the dataframe" (should be GCS_WGS_1984)
 - d. Click "OK"
 - e. Coordinates are now added to the attribute table; can be entered into GPS

- f. Next, change the coordinate system back to “Predefined/Projected Coordinate Systems/State Plane/Nad 1983/Delaware” (To make this changing easier, just click “Add To Favorites” when the desired coordinate system is selected)
- (11) Label the buffer plot locations for mapping purposes
- a. Double click on the new point layer
 - b. Click on the “Labels” tab
 - c. Check “Label features in this layer”
 - d. Label Field should be “Id”
 - e. Choose an appropriate font, color, etc. and click “OK” (you can experiment with placement if you choose)

APPENDIX F: SOIL SERIES OF DELAWARE AND MARYLAND

Maryland and Delaware Soil Series

Soil Series		State	Hydrologic Class	K value	F value	Updated soil series name
Bo	Borrow pits	DE	3	23	0.2252	
EI	Elkton sandy loam, thin subsoil	DE	1	0.13	0.02657	Bkl
EoB	Evesboro sand 0-5% slopes	DE	3	11	0.2077	Eves
EoD	Evesboro sand 5-15% slopes	DE	3	11	0.2077	
EsD	Evesboro loamy sand 5-15% slopes	DE	3	11	0.1551	
EvA	Evesboro loam sand, loamy substratum, 0-2% slopes	DE	3	11	0.1551	Fort
EvB	Evesboro loam sand, loamy substratum, 2-5% slopes	DE	3	11	0.1551	Farl
Fa	Fallsington sandy loam	DE	2	1.32	0.09032	Hurl
Fs	Fallsington loam	DE	3	3.46	0.07456	
Jo	Johnston silt loam	DE	3	13	0.02331	Porl
Ka	Keyport sandy loam	DE	3	13	0.02703	Hamb
KbA	Kenansville loamy sand, 0-2% slopes	DE	3	3.3	0.1308	Rose
KfA	Keyport fine sandy loam, 0-2% slopes	DE	3	13	0.02436	Keyp
Kl	Klej loamy sand	DE	3	23	0.1254	Hamm
Os	Osier loamy sand	DE	3	23	0.1394	
Pm	Pocomoke sandy loam	DE	2	1.3	0.027	Pone
Po	Pocomoke loam	DE	2	1.3	0.0216	
RuA	Rumford loamy sand, 0-2% slopes	DE	3	4.15	0.08649	Down
RuB	Rumford loamy sand, 2-5% slopes	DE	3	4.15	0.08649	
RuC	Rumford loamy sand, 5-10% slopes	DE	3	4.15	0.08649	
Ry	Rutlege loamy sand	DE	3	13	0.08099	
SaA	Sassafras sandy loam, 0-2% slopes	DE	3	3.46	0.0361	
SaB	Sassafras sandy loam, 2-5% slopes	DE	3	3.46	0.0361	Gree
Sw	Swamp	DE	3	11	0.1037	
Tf	Tidal marsh, fresh	DE	3	10.1	0.003577	
Wo	Woodstown sandy loam	DE	2	1.32	0.03896	

APPENDIX G: TIERED AQUATIC LIFE USE MODEL

Wetland Structure includes vegetation, soils and hydrology.

Wetland Functions include plant community, wildlife habitat, hydrologic flux and storage, biogeochemical cycling and intact buffer.

Tiered Aquatic Life Use Conceptual Model: Draft Biological Tiers - 1

(10/22 draft)

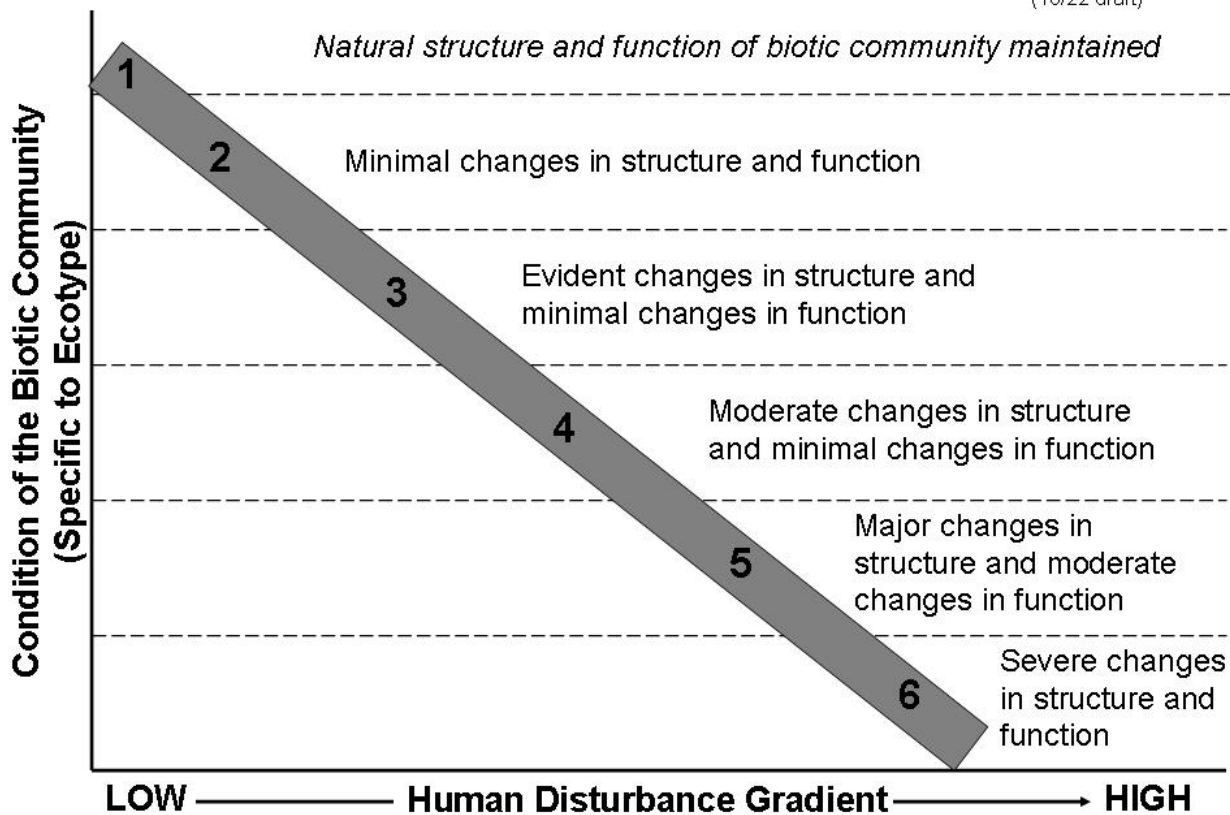

APPENDIX H: Random Number Tables

Random # between 11 and 31						
13	23	18	13	28	14	28
22	22	30	25	24	21	24
23	12	27	31	20	23	15
23	15	23	14	26	28	22
23	14	30	15	28	27	11
25	13	11	30	16	14	12
24	11	15	17	19	24	29
14	30	28	13	28	23	11
13	12	15	26	30	30	17
14	23	26	21	29	18	27
24	21	21	24	25	18	26
29	18	15	19	29	19	30
20	26	24	13	20	27	23
17	14	15	20	25	11	26
14	12	19	23	30	29	31
26	18	27	25	12	28	30
28	23	14	21	20	28	14
22	25	27	13	19	27	20
28	29	20	30	20	26	23
19	17	17	29	19	29	17
15	29	15	12	19	15	20
30	16	13	28	26	24	20
18	24	31	31	21	22	23
24	15	19	12	25	19	26
16	17	24	27	21	17	17
13	29	15	18	22	21	13
12	17	19	16	23	27	19
29	27	18	20	16	26	11
14	13	30	20	20	27	23
25	28	17	29	26	28	14
21	17	21	21	23	26	16
23	16	26	15	18	28	14
24	17	13	28	21	24	11
13	22	29	11	18	22	26
13	17	13	21	25	27	24
13	12	24	29	22	12	25
13	16	31	21	24	17	26
20	15	25	20	28	19	25
23	18	12	20	15	13	15
29	26	30	18	29	18	28
13	25	16	16	14	17	22

Random # 360

252	87	7	174	337	351	220	328	105
91	40	224	217	345	332	4	189	264
149	32	132	106	256	121	147	319	229
94	176	327	295	142	247	320	200	262
322	105	118	309	328	325	270	25	336
160	196	129	123	18	286	226	136	130
310	210	278	290	136	67	139	209	20
81	120	178	121	236	250	288	340	19
246	173	61	49	64	194	102	220	212
42	115	97	132	335	280	168	230	101
242	97	345	154	305	263	60	116	294
19	108	349	336	157	71	282	304	264
319	27	67	144	109	290	79	67	227
283	92	27	191	127	350	16	239	265
319	250	148	261	115	190	145	114	60
133	211	57	117	121	18	274	192	37
289	92	357	213	227	223	241	310	256
347	47	243	262	245	283	40	99	137
173	168	153	46	283	138	309	193	140
281	42	92	79	58	86	218	148	259
288	166	227	50	214	257	205	98	88
230	59	233	1	354	237	265	347	121
133	195	352	308	239	72	6	219	26
342	161	303	294	112	191	29	163	273
139	302	209	127	96	343	58	133	208
178	30	67	294	37	153	124	94	338
258	108	151	76	107	212	152	86	315
68	153	283	107	33	197	0	145	24
43	319	239	223	18	322	33	318	93
29	87	67	55	357	180	342	235	338
216	229	188	197	154	315	62	166	65
251	61	59	140	149	178	124	91	150
149	240	49	135	198	260	351	172	315
268	130	237	339	34	264	264	64	16
337	105	70	238	95	328	64	315	209
261	43	91	304	175	190	347	201	127
95	229	61	13	59	171	230	12	238
4	170	47	117	68	354	40	83	54
267	189	214	286	159	97	311	27	196
339	151	106	30	135	120	166	175	130
185	25	215	227	184	358	313	92	51
116	230	208	153	287	82	339	267	195
62	211	125	289	199	252	9	125	72
279	190	143	44	195	146	162	58	68
6	166	357	306	329	37	27	5	108
246	360	338	47	242	71	196	208	150
146	169	102	246	336	355	95	192	54
239	53	31	302	329	27	249	271	73

APPENDIX I: SOIL TEXTURE GUIDE

Soil Texture By Feel Flow Chart

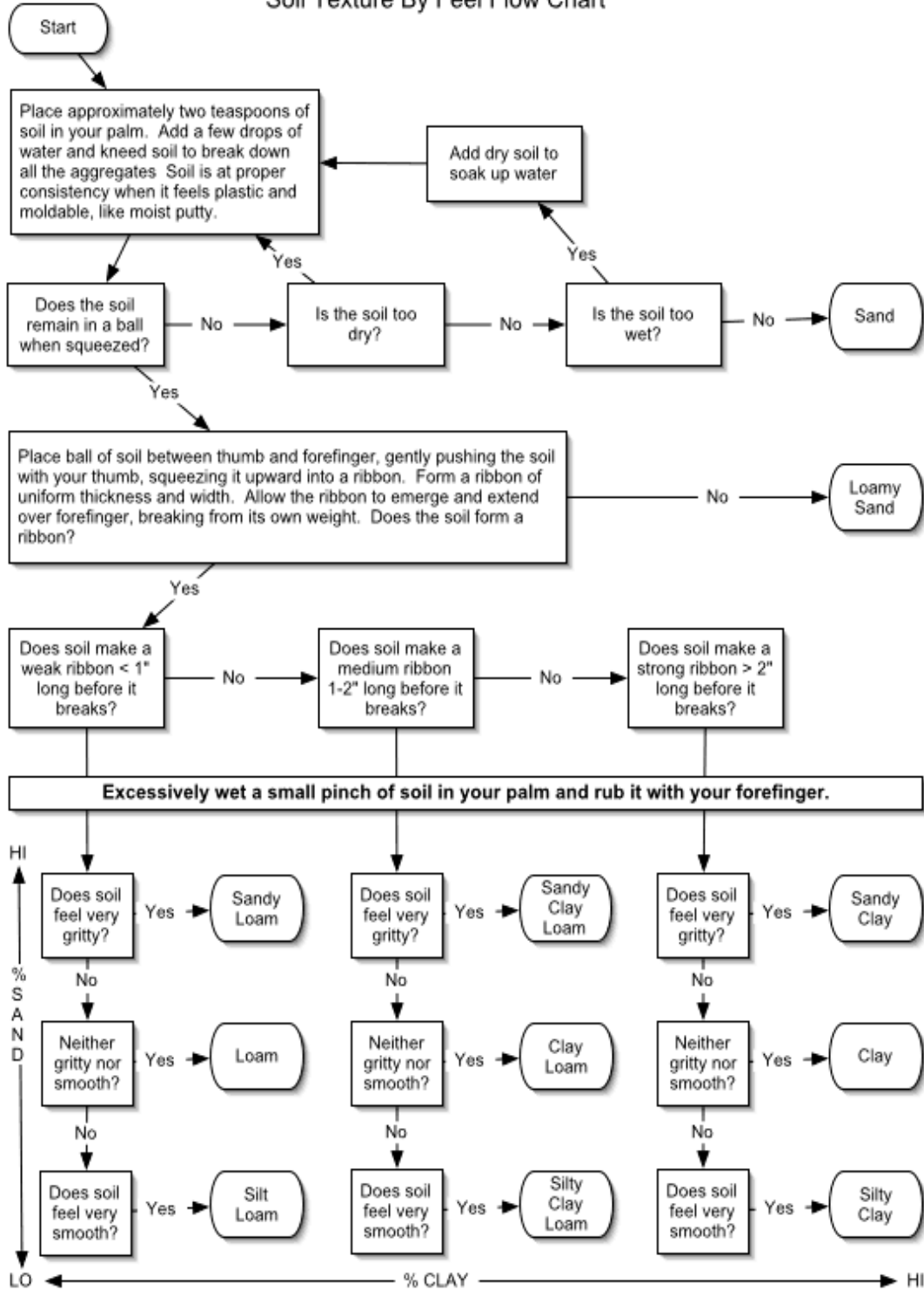

GLOSSARY

Amendments – things added to increase the amount of organic matter in the wetland to improve the condition of the soil for better plant growth. Examples could be straw, hay, bedding, corn silage, etc.

Assessment Area (AA) – area within the wetland that is sampled using the Delaware Comprehensive Assessment Procedure. All measurements are performed in the AA with the exception of hydrology, buffer and landscape methods. To locate the assessment area in the wetland, refer to p. 3.

Buffer Plot – plot located in a forested cover type that comprises >10% of the buffer, which is the area adjacent to the wetland. There are two types: non-riverine and riverine buffer plots. To locate the buffer plots, refer to p. 4.

Channelized Stream – stream channel that has been excavated to a deeper depth and at the same time straitened to provide improved drainage.

Closed Basin – a wetland with no effective surface water inlets or outlets

Coarse Woody Debris (CWD) – logs or stumps of a tree. Only CWD that is ≥ 15 cm dbh is measured.

Constructed Road – road where fill was either brought on site or excavated from ditches on either side of the road to elevate the surface of the road higher than the surrounding area

DBH – diameter of a tree at breast height. However, since people vary in height, the diameter is actually measured at 1.28 m from the highest above-ground point of the tree trunk.

Ditch - A man-made, open drainage-way in or into which excess surface water or groundwater drained from land, stormwater runoff, or floodwaters flow either continuously or intermittently

Fill – any soil, debris, garbage, or excavated material including dredge spoil.

Inlet – where water enters the wetland.

Invasive Species – a non-native or introduced species that has developed a tremendous capacity for reproduction and distribution throughout its new home and that also has a negative impact on environmental, economic, or public welfare priorities. Appendix B. is a list of invasive species found in Delaware.

Logging road - roads that are cut through an area but that were not filled excessively to elevate the surface of the road higher than the surrounding area

Mapped Wetland – the wetland that has been chosen for the study.

Microtopography – the natural configuration of the surface of the land on a small scale including changes in elevation due to the presence of hummocks, mounds and depressions.

Outlet – where surface water leaves the wetland.

Random Site – a randomly generated site produced by the EPA’s Environmental Monitoring and Assessment Program (EMAP). The site was selected from a group of wetlands that fit a specific Hydrogeomorphic subclass (HGM). The classification of the wetland group was derived from a modified version of the National Wetlands Inventory Map (NWI).

Reference Site - a site that was selected based on a qualitative ranking of low, medium, or high.

Regulatory Wetland – wetland delineated by the Army Corps of Engineers 1987 manual as under federal jurisdiction

Sapling – trees that are <7.5 cm dbh and ≥ 1 m in height.

Shrub – woody species that do not have the potential to become canopy trees. To be counted as a shrub, the plant can be either a single shoot or clump of shoots that originate from a single root system; the minimum height for shrubs is 1m.

Snag – standing dead trees ≥ 15 cm dbh and ≥ 2 m in height.

Spoil pile – pile of earth and rock that was excavated or dredged.

Tree - ≥ 7.5 cm Diameter Breast Height (DBH) and ≥ 1 m in height

Understory - woody and herbaceous species that are < 1.0 m or the height of the tallest herbaceous species.

Vegetation Plot – area inside vegetation zone within the Assessment Area that is actually sampled. At least one vegetation plot is randomly placed in each vegetation zone. To determine where to place the vegetation plot within the Assessment Area, refer to p. 3.

Vegetation Zone – the type of vegetation; i.e. open water, forested, emergent. Only the dominant vegetation zones, those that are $\geq 10\%$ in the Assessment Area, are sampled.

Vine – a perennial plant, ≥ 1 meter tall, whose stem requires support and which climbs by tendrils or twining or creeps along the ground.

Trees and Saplings Datasheet

DE Comprehensive Wetland Assessment V.5.1

Sheet ____ of ____

Site # _____ Site Name: _____ Date ____/____/____

Veg Plot # _____ Plot size (m) _____ Observers: _____

Vegetation Zone _____

I.A. Trees (≥ 7.5 cm DBH and ≥ 1 m in height) in 8.92m radius 17.84 m diameter plot)

Species	DBH at 1.28m recorded in cm to the nearest tenth (i.e. 25.6cm)						

II.A. Saplings(all trees < 7.5 cm DBH and ≥ 1.0 m in height) subsampled* (yes no) % of plot _____

Species name	Count	Line Total

* If plot is subsampled, examine the un-sampled portion for additional species. Record "unsampled" in count column
 Comments: _____ Entered _____ Checked

Shrubs and Vines Datasheet

DE Comprehensive Wetland Assessment v.5.1

Sheet ____ of ____

Site # _____

Site Name: _____

Date ____/____/____

Veg Plot # _____

Plot size (m) _____

Vegetation Zone _____ Observers: _____

I. Shrubs (# of stems > 1.0 m high.)		Subsampled?* (yes no)	Count of Stems	Line Total
C	I	Species in 8.92m radius plot % of plot _____		

* If plot is subsampled, examine the un-sampled portion for additional species. Record "unsampled" in count column

II. Vine Species (\geq 1m tall)	species present in 8.92m tree plot; do NOT subsample

Comments:

III. Blackberry Spp.
 (do not include dewberry species)
 In Tree Plot (**do not** subsample)
 Yes _____ No _____

C= collected _____ Entered
 I = Identified _____ Checked

Understory Datasheet DE Comprehensive Wetland Assessment v.5.1

Site # _____ Site Name _____ Date ____/____/____
 Veg Plot # _____ Vegetation Zone: _____
 Observers: _____

(Cover estimated in four subplots (2 X 0.5 m) in each of tree plot) Enter Midpoint									
C	I	I.Understory Species	Subplot Number				Additional Species	C	I
			1	2	3	4			
		Unvegetated							

C= collected I = Identified

Cover Classes	MidPt	Cover Cl	MidPt
0	0	26-50%	38
<1%	0.5	51-75%	63
1-5%	2.5	76-99%	88.5
6-25%	15.5	100%	100

Entered
Checked

Comments:

Continue on back if necessary ----->

Snags/Downed Wood

DE Comprehensive Assessment v.5.1

Site # _____ Site Name _____ Date ____/____/____

Vegetation Zone: _____ Observers _____

Plot Shape: Circular Rectangular: dimensions _____

I. Snags ($\geq 15\text{cm}$ dbh and $>2\text{m}$ tall)

DBH (cm)	DBH (cm)	DBH (cm)	DBH (cm)	DBH (cm)	DBH (cm)

IV. Large Downed Wood (LDW)($\geq 15.0\text{cm}$) and Coarse Woody Debris (CWD)($< 15.0\text{cm}$):

Transect Method record dbh of LDW and tally CWD at each intersection along transect

	Trans A	Trans B	Trans C	Trans D	Trans E	Trans F	Trans G
	Transect Length/angle	Transect Length/angle	Transect Length/angle	Transect Length/angle	Transect Length/angle	Transect Length/angle	Transect Length/angle
Coarse Woody debris Tally (1-15cm)							
Large Downed Wood ($>15\text{cm}$)	DBH and angle e.g. 15cm/37°	DBH and angle e.g. 15cm/37°	DBH and angle e.g. 15cm/37°	DBH and angle e.g. 15cm/37°	DBH and angle e.g. 15cm/37°	DBH and angle e.g. 15cm/37°	DBH and angle e.g. 15cm/37°

Comments:

_____ Entered
_____ Checked

Microtopography/Soil/Sphagnum

DE Comprehensive Assessment v. 5.1

Site # _____
Date ____/____/____

Site Name _____
Observers _____

Veg Plot _____ Plot Dimension _____

Vegetation Zone: _____

II. Microtopography **III. Soils** Series _____

Quarter	tip-ups	hummocks	Horizon	depth	Comments (color, texture)
1			O		
2			A		
3			Plow Layer?(Yes No)		
4			Drain Class		
			Hydric indicators		

Veg Plot _____ Plot Dimension _____

Vegetation Zone: _____

II. Microtopography **III. Soils** Series _____

Quarter	tip-ups	hummocks	Horizon	depth	Comments (color, texture)
1			O		
2			A		
3			Plow Layer?(Yes No)		
4			Drain Class		
			Hydric indicators		

Veg Plot _____ Plot Dimension _____

Vegetation Zone: _____

II. Microtopography **III. Soils** Series _____

Quarter	tip-ups	hummocks	Horizon	depth	Comments (color, texture)
1			O		
2			A		
3			Plow Layer?(Yes No)		
4			Drain Class		
			Hydric indicators		

Sphagnum Veg Plot

sample #	#	Sub Plot #	Moisture regime	Habitat

Riverine Morphology Datasheet
DE Comprehensive Wetland Assessment v.5.1

Date ____/____/____

Site Number: _____ Site Name: _____

Team: _____

Location (in AA)	Bankfull	Top of bank
	Depth	Depth
25m downstream		
50m center point		
75m upstream		

Location (out AA)		
	Depth	Depth
100m downstream		
200m downstream		
300m downstream		
400m downstream		
500m downstream		
100m upstream		
200m upstream		
300m upstream		
400m upstream		
500m upstream		

"Bankfull" is the height of the stream that fills the stream channel.
At least 2 indicators must be present to determine this
 "Bankfull" is not always the height of the water at time of sampling
 "Top of Bank" indicates the actual top of the channel

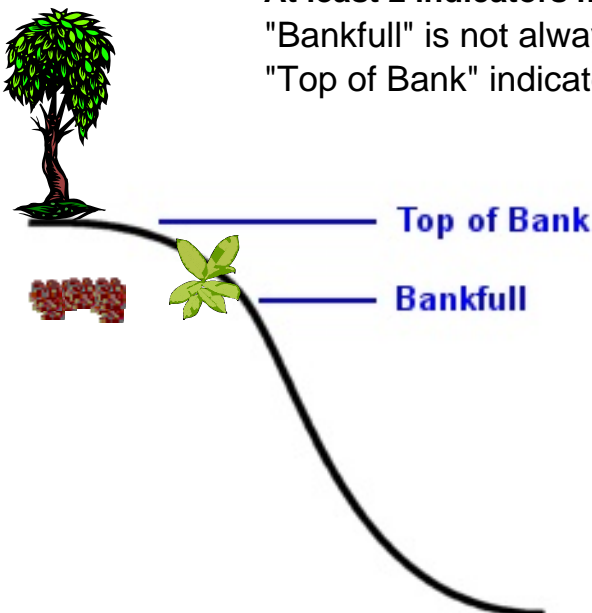

_____ Entered
 _____ Checked

Riverine Hydrology Datasheet
DE Comprehensive Wetland Assessment v.5.1

Date ____/____/____

Circle
Stream order:

1	2
3	4
5	6

Site Number: _____ Site Name: _____

Team: _____

Mark the dominant condition that occurs in each specified area of stream channel

Channelization: Stream has been straightened and deepened

Levee: Spoils from channelization is deposited along streambank reducing overbank flooding

Hydrologic Alteration: Anthropogenic obstruction to stream flow

Other: Small man-made obstruction/ provide description below

Bridge: Spans the waterway without obstructing flow

Culvert: passes water beneath a road through a pipe

I. Inside Assessment Area

Distance	Channelization Yes No	If Yes, type of Channelization:					Other Hydrologic Alterations				
		Levee Present		Levee Present both sides of channel	No Levee	Channelization not Maintained or not effective	Bridge	Culvert	Dam	Foot Bridge	Other*
		opposite side of AA	AA side of channel								
0-50m Upstream	Yes No										
0-50m Downstream	Yes No										

II. Outside AA(Upstream)

Distance	Channelization Yes No	If Yes, type of Channelization:					Other Hydrologic Alterations				
		Levee Present		Levee Present both sides of channel	No Levee	Channelization not Maintained or not effective	Bridge	Culvert	Dam	Foot Bridge	Other*
		opposite side of AA	AA side of channel								
0-100m	Yes No										
100-200m	Yes No										
200-300m	Yes No										
300-400m	Yes No										
400-500m	Yes No										

II. Outside AA (Downstream)

Distance	Channelization Yes No	If Yes, type of Channelization:					Other Hydrologic Alterations				
		Levee Present		Levee Present both sides of channel	No Levee	Channelization not Maintained or not effective	Bridge	Culvert	Dam	Foot Bridge	Other*
		opposite side of AA	AA side of channel								
0-100m	Yes No										
100-200m	Yes No										
200-300m	Yes No										
300-400m	Yes No										
400-500m	Yes No										

* Give a brief description of other alteration:

Comments for upstream section:

Comments for downstream section:

____ Entered
 ____ Checked

Hydrology Datasheet

Ditches in 200m buffer

DE Comprehensive Wetland Assessment v.5.1

Site # _____ Site Name: _____

Observers: _____ Date ____ / ____ / ____

Location (from GPS)

Measurement

Latitude	Longitude	Distance from Center	Bearing to Center	Depth

_____ Entered
 _____ Checked

Buffer Landuse

DE Comprehensive Wetland Assessment v.5.1

Site # _____

Site Name: _____

Observers: _____ Date ____/____/____

Ground truth the Landuse in the 100 & 200 meter buffers

	200m	100m
Agriculture (Pasture/Hay/Crops)	_____ %	_____ %
Developed (Urban/Res/Roads)	_____ %	_____ %
Barren	_____ %	_____ %
Other	_____ %	_____ %
Forested	_____ %	_____ %
	$\Sigma = 100\%$	$\Sigma = 100\%$

Forest types in 200m buffer

		% of Forested Buffer	
Forest Type*	Circle One		Buffer Plot #
	Wetland Upland		
	Wetland Upland		
	Wetland Upland		
	Wetland Upland		
		$\Sigma = 100\%$	

- * for each buffer with a different habitat then the AA fill out a buffer basal area datasheet
- * if the buffer is within the same wetland as the AA the buffer plot is randomly selected from vegetation plots

Buffer Overstory Datasheet

DE Comprehensive Wetland Assessment v.5.1

Site # _____ Site Name: _____ Date ____/____/____

Buffer Plot # _____ Plot size (m) _____ Observers: _____

Percent of the total forest cover in the 200m buffer of AA that this plot represents _____

Forest Type _____ Wetland or Upland (circle one)

Distance to Plot (from assessment area) _____ Plot direction _____

Plot lat _____ Plot long _____

Use data from veg plot? Yes no If yes - veg plot # _____ (randomly select tree plot)

I. Trees (>15.0cm DBH) in 8.92m radius plot

Species	DBH at 1.28m recorded in cm to the nearest tenth (i.e. 25.6cm)						

Comments:

_____ Entered

_____ Checked

Site Information Datasheet
DE Comprehensive Wetland Assessment
Version 5.1 2/06/08

Site # _____ Site Name _____ Date ____/____/____
 Field Crew _____ Crew Leader Initials _____
 HGM Subclass _____ Reference or Assessment Site (circle one)
 Natural, re-establishment, establishment, rehabilitation, enhancement (circle one)
 Watershed _____ Photos: _____ Wetland Size(ha) _____
 lat/long _____
 AA moved from original location? (yes no) if yes reason: _____

Vegetation Zones		
I.A. Wetland Vegetation Zones Present		
<input type="checkbox"/> Emergent/ herbaceous	<input type="checkbox"/> Hardwood forest	<input type="checkbox"/> Agriculture/pasture
<input type="checkbox"/> Scrub-shrub	<input type="checkbox"/> Mixed Hardwood/Pine forest	<input type="checkbox"/> Agriculture/cropland
<input type="checkbox"/> Natural pine forest	<input type="checkbox"/> Mixed Pine/Hardwood forest	<input type="checkbox"/> Open water
<input type="checkbox"/> Planted pine forest	<input type="checkbox"/> Impervious surface	
<input type="checkbox"/> Mowed area	<input type="checkbox"/> Unvegetated	<input type="checkbox"/> Other _____

I.B. Vegetation Disturbance	Stand Age _____
<input type="checkbox"/> No evidence of vegetation disturbance within past 50 years	Converted to pine? Yes or no
<input type="checkbox"/> Vegetation clear cut or otherwise removed:	% of AA affected
<input type="checkbox"/> within past 30-49 years	<input type="checkbox"/> within past 3-14 years
<input type="checkbox"/> within past 15-29 years	<input type="checkbox"/> within past 2 years
<input type="checkbox"/> Forest selectively logged (select one):	
<input type="checkbox"/> <10% of trees removed	<input type="checkbox"/> >10% of trees removed
<input type="checkbox"/> AA affected by a continual or periodic disturbance within past 2 years i.e. road, maintained ditch bank, plowing etc.	
<input type="checkbox"/> < 10% of AA	<input type="checkbox"/> > 10% of AA
<input type="checkbox"/> Assessment area converted to land-use which makes restoration success highly unlikely(urban or suburban)	
<input type="checkbox"/> Wetland has been restored Year of restoration if known _____	
<input type="checkbox"/> Wetland has been created i.e. stormwater pond or old borrow pit	

II. Microtopographic Alterations (check all features present)	_____ % of AA affected
<input type="checkbox"/> Windrows	<input type="checkbox"/> Skidder tracks
<input type="checkbox"/> Road (any type)	<input type="checkbox"/> Bedding
<input type="checkbox"/> Plowing	<input type="checkbox"/> Grading
	_____ microtopo restored to site
	_____ no microtopographic alterations
	_____ other _____

III. Fill (i.e. windrows, dumped or soil, debris, garbage) Check One	
<input type="checkbox"/> No fill in assessment area	<input type="checkbox"/> ≥ 50% < 75% of AA covered with fill
<input type="checkbox"/> < 10% of AA covered with fill	<input type="checkbox"/> ≥ 75% of AA covered with fill
<input type="checkbox"/> ≥ 10% < 50% of AA covered with fill	

IV. Natural Hydrology Sources for Depressions Only (check one)	
<input type="checkbox"/> Inlet	<input type="checkbox"/> Closed Basin
<input type="checkbox"/> Outlet	<input type="checkbox"/> Flowthrough

Datasheets (write in the number of sheets completed for each)

Site Information		Snag/ micro		Riv. Hydro	
Trees		Hydro - In		Riv. Buffer	
Shrubs		Hydro Out		Gen. Buffer	
Understory Plots		Channel morph		rapid assess.	

Need to return to site?
 (Yes or No)

V. Hydrologic Disturbance

a. Riverine Floodplain Condition (Check One)	Indication of overbank flooding? Yes No (circle one)
<input type="checkbox"/> No alterations (i.e. ditches, mechanical alterations to substrate, fill, excavations) within the Assessment Area	
<input type="checkbox"/> Ditches present on the floodplain surface within the Assessment Area but they are no longer effective (i.e. ditches have become filled with debris and are not maintained)	
OR	
<input type="checkbox"/> <10% of the floodplain within the Assessment Area has been altered (i.e. ditches that provide effective drainage, impoundment of water, excavation of substrate, fill or excessive sediment)	
<input type="checkbox"/> > 10% and < 75% of the floodplain within the Assessment Area has been altered (i.e. ditches that provide effective drainage, impoundment of water, excavation of substrate, fill or excessive sediment)	
<input type="checkbox"/> > 75% of the floodplain within the Assessment Area has been altered (i.e. ditches that provide effective drainage, impoundment of water, excavation of substrate, fill or excessive sediment)	

b. Non-Riverine	
<input type="checkbox"/> Ditch/ stormwater drain diverting water into site	<input type="checkbox"/> Other
<input type="checkbox"/> Ditch diverting water out of site	<input type="checkbox"/> < 10% of site excavated
<input type="checkbox"/> Ditch present within site with unknown effect	<input type="checkbox"/> 10-75% of site excavated
<input type="checkbox"/> Structure (road or artificial control) damming water in site	<input type="checkbox"/> >75% of site excavated
<input type="checkbox"/> Structure (road or artificial control) restricting water into site	<input type="checkbox"/> Hydrology restored to site

Qualitative Condition: Least Disturbed	1	2	3	4	5	6	Highly Disturbed	(circle one number)
---	----------	----------	----------	----------	----------	----------	-------------------------	----------------------------

VII. Site Sketch

VIII. Comments: (include if the site needs to be revisited and why and if any decisions were made on site and a justification)

Entered
 Checked

*If site is restored or created make sure that DE Restoration Info Datasheet is completed which can be obtained from DNREC/ DWR/ Watershed Assessment

Delaware Restored/Created Site Information Datasheet

Site Name _____

Existing Project ____ Potential Project ____

Information Source _____

Funding needed? ____

Type of funding: ____ federal
 ____ non-federal
 ____ in-kind services

Landowner Information

First Name _____

Street Address _____

Last Name _____

Organization _____

City _____

Phone Number _____

State _____

Other Phone _____

Zip Code _____

Additional Landowners:

Site Information

Date construction completed _____

Public property? _____

Photos taken? _____

Total restoration size (actual): _____

Permits required

Date obtained

{in ha or linear feet for streams;
includes all types of restoration
at this location}

permit 1 _____

permit 2 _____

permit 3 _____

Site watershed _____

Site county _____

Easement? ____ easement type _____

Lat _____ **Long** _____

Conservation program _____

Tax parcel ID _____

term _____

Long-term goal _____

Directions to site:

continued on other side----->

Restoration Type

Type (federal definitions - *see below)

Restoration
 Establishment
 Enhancement
 Protection/Maintenance
 re-establishment
 rehabilitation

Habitat Type	Actual Size (ha or linear feet)	Estimated Size (ha or linear feet)	Description
<input type="checkbox"/> upland	_____	_____	_____
<small>(list type: wildflower meadow, open space, urban garden, warm season grass meadow, shrub, or forest)</small>			
<input type="checkbox"/> wetland			
<input type="checkbox"/> tidal	_____	_____	_____
<input type="checkbox"/> non-tidal	_____	_____	_____
<input type="checkbox"/> invasive species			
<input type="checkbox"/> buffer	_____	_____	_____
cover: grass or forest (circle one)			
target: stream/ditch or wetland (circle one)			
<input type="checkbox"/> selective thinning	_____	_____	_____
<input type="checkbox"/> stream	_____	_____	_____

Partners

Organizations	Contribution Type (technical or financial)	Amount	Contribution Source
Lead group _____	_____	_____	_____
Contact name _____			
Contact phone _____			
Partner 1	_____	_____	_____
Partner 2	_____	_____	_____
Partner 3	_____	_____	_____
Partner 4	_____	_____	_____
Partner 5	_____	_____	_____

continued on other side----->

Construction Techniques

General techniques

- _____ inlet
- _____ outlet
- _____ closed basin
- _____ ditch plug
- _____ microtopography
- _____ score (1-10) _____
- _____ islands/macrotopography
- _____ excavation
- _____ control structure
- _____ boards
- _____ pipe
- _____ burning
- _____ log toe protection
- _____ rock toe protection
- _____ cross vanes
- _____ log vanes
- _____ rock vanes
- _____ root wads
- _____ j-hooks

Amenities

- _____ top soil
- _____ horse bedding
- _____ straw/hay
- _____ coarse woody debris
- _____ biologs
- _____ coconut mats
- _____ rip rap
- _____ liners
- _____ native plantings
- _____ live branch layering
- _____ herbicide control
- _____ date of last application: _____
- _____ other _____

Hydrology

- _____ % permanent water _____
- _____ primary water source _____
- _____ % open water _____

Invasive species management

- _____ wet-glove
- _____ backpack sprayer
- _____ mechanical
- _____ drip
- _____ biological control
- _____ injection
- _____ cut stump
- _____ burn

Invasive species

- percent *Typha* _____
- percent *Phragmites* _____
- other invasives _____ percent
- species 1 _____
- species 2 _____
- species 3 _____

Site Management

- Long-term management needed? _____
- Type _____
- Party responsible _____
- Entered** _____
- Checked** _____

Site Comments

continued on other side----->

***Federal Agency Definitions for Wetland Tracking**
(www.epa.gov/owow/wetlands/restoration/defs.htm#Fed)

Restoration: the manipulation of the physical, chemical, or biological characteristics of a site with the goal of returning natural/historic functions to former or degraded wetland. For the purpose of tracking net gains in wetland acres, restoration is divided into:

Re-establishment: the manipulation of the physical, chemical, or biological characteristics of a site with the goal of returning natural/historic functions to a former wetland. Re-establishment results in rebuilding a former wetland and results in a gain in wetland acres.

Rehabilitation: the manipulation of the physical, chemical, or biological characteristics of a site with the goal of repairing natural/historic functions of degraded wetland. Rehabilitation results in a gain in wetland function, but does not result in a gain in wetland acres.

Establishment: the manipulation of the physical, chemical, or biological characteristics present to develop a wetland that did not previously exist on an upland or deepwater site. Establishment results in a gain in wetland acres.

Enhancement: the manipulation of the physical, chemical, or biological characteristics of a wetland (undisturbed or degraded) site to heighten, intensify, or improve specific function(s) or for a purpose such as water quality improvement, flood water retention or wildlife habitat. Enhancement results in a change in wetland function(s) and can lead to a decline in other wetland functions, but does not result in a gain in wetland acres. This term includes activities commonly associated with the terms enhancement, management, manipulation, directed alteration.

Protection/Maintenance: the removal of a threat to, or preventing decline of, wetland conditions by an action in or near a wetland. Includes purchase of land or easement, repairing water control structures or fences, or structural protection such as repairing a barrier island. This term also includes activities commonly associated with the term preservation. Protection/Maintenance does not result in a gain of wetland acres or function.

FIELD CREW LEADER CHECK LIST

Field Crew Leader Check List

- Confirm that all data forms and maps are in folder
- Confirm buffer plots are selected
- Assign field tasks to crew
- Review size limits for vegetation measurements at the beginning of sampling
 - Have field crew check DBH height (1.28m)
 - Saplings and trees count at 2 stems if split < 1.28m and 1 stem if split >1.28m
 - Shrubs must be >1m tall and stems must be >1m long
- Remind field crewmembers to implement double checks among crewmembers that are collecting vegetation data
 - Recorder should identify dominant trees to double check identification
 - Crewmembers that are collecting understory data should list shrubs species to make sure they were recorded
 - Crewmembers that are collecting overstory data should note less common understory species to make sure that they are on the understory species list
- Remind crewmembers to measure trees and sapling near edge of vegetation plots
- If >3 additional species are found during the extra 4 minute understory species search, have crew search for an additional minute until no more than 1 additional species is found
- Check all datasheets before leaving the site and list anything that was not completed on the site info sheet