

Smithsonian Series in Comparative Evolutionary Biology

V. A. Funk, Smithsonian Institution

Peter F. Cannell, Smithsonian Institution

The intent of this series is to publish innovative studies in the field of comparative evolutionary biology, especially by authors willing to introduce new ideas or to challenge or expand views now accepted. Within this context, and with some preference toward the organismic level, a diversity of viewpoints is sought.

Advisory Board

Richard Bateman
Daniel R. Brooks
William DiMichele
Michael Donoghue
Douglas Erwin
David Grimaldi
David Hillis
Richard Mooi
Robert Voss

Royal Botanic Garden, Edinburgh
University of Toronto
Smithsonian Institution
Harvard University
Smithsonian Institution
American Museum of Natural History
University of Texas at Austin
California Academy of Sciences
American Museum of Natural History

ALSO IN THE SERIES

Parascript

Parasites and the Language of Evolution
Daniel R. Brooks and Deborah A. McLennan

The Development and Evolution of Butterfly Wing Patterns
H. Frederick Nijhout

**HAWAIIAN
BIOGEOGRAPHY**



**EVOLUTION
ON A
HOT SPOT
ARCHIPELAGO**

EDITED BY
WARREN L. WAGNER
AND V. A. FUNK

SMITHSONIAN
INSTITUTION
PRESS

WASHINGTON
AND LONDON

APPENDIX 16.2. Data Matrix of Character States for the Cladistic Analysis of Hawaiian and Related Pacific Species of *Scaevola*

The characters and character states are defined in Appendix 16.1. Missing data are indicated by question marks.

OTU	Character														
	1	2	3	4	5	6	7	8	9	10	11	12	13	14	15
<i>S. sericea</i>	1	0	0	0	0	0	0	0	0	0	1	0	0	0	1
<i>S. coriacea</i>	0	0	2	1	1	2	1	0	0	0	1	0	0	0	1
<i>S. gaudichaudii</i>	0	1	2	1	0	2	1	1	0	0	0	0	0	0	0
<i>S. gaudichaudiana</i>	0	1	0	1	0	2	1	0	0	0	0	1	0	1	0
<i>S. chamissoniana</i>	0	1	0	1	0	2	1	0	0	0	0	0	0	1	0
<i>S. mollis</i>	1	1	1	1	0	1	1	0	0	1	0	0	0	1	0
<i>S. procera</i>	0	1	1	1	0	1	1	0	0	1	0	0	0	1	0
<i>S. kilaueae</i>	0	1	0	1	0	2	1	0	0	0	0	1	0	0	1
<i>S. glabra</i>	0	1	2	0	1	0	0	0	1	0	1	0	0	1	0
<i>S. montana</i>	1	0	0	1	0	0	0	0	1	1	1	0	0	0	1
<i>S. coccinea</i>	0	0	2	0	1	0	0	1	?	0	1	0	0	1	1
<i>S. tahitiensis</i>	1	1	0	0	0	1	0	1	0	1	1	0	1	0	1
<i>S. subcapitata</i>	0	1	0	1	1	0	0	1	0	1	1	1	1	1	1
<i>S. floribunda</i>	1	1	0	1	0	0	0	1	0	1	1	0	0	0	1
<i>S. nubigena</i>	0	1	0	0	0	0	0	1	0	1	0	0	0	0	1

17

Biogeographic Patterns in the Hawaiian Islands

V. A. FUNK AND WARREN L. WAGNER

The Hawaiian Islands formed successively over a fixed geologic hot spot. The eight high islands (Ni'ihau, Kaua'i, O'ahu, Moloka'i, Lana'i, Kaho'olawe, Maui, and Hawai'i) occupy the southeast end of a long line of low islands and seamounts known as the Hawaiian Ridge and Emperor Chain. Carson and Clague have summarized the geologic history of the islands (see this volume, Chapter 2). In short, the oldest parts of the chain formed 75 to 80 million years ago (Ma) and the youngest are being formed today. The oldest of the high islands, Kaua'i, was formed ca. 5.1 Ma, and the youngest, Hawai'i, has three active volcanoes with the oldest flows formed no more than 0.5 Ma. Of major importance to the biogeographer were events that altered connections between certain volcanoes of the Hawaiian Islands during the Pleistocene. The most significant of these events was the breakup of a large island referred to as Maui Nui into the current islands of Moloka'i, Maui, Kaho'olawe, and Lana'i. O'ahu and Moloka'i were also connected by a low-elevation land bridge (see Carson and Clague, this volume, Chapter 2). The term *Maui Nui complex* is used to refer to two or more of the islands of Moloka'i, Maui, Lana'i, or Kaho'olawe, not necessarily to the giant island that existed in the Pleistocene.

The Hawaiian Islands are the most isolated major island group in the world. They have always been about as remote from all the continents as they are presently. Thus, the biota of the Hawaiian Islands is the result of dispersal from many different parts of the world, as is reflected by the

varied geographic ranges of the ancestors of the endemic plants and animals (Fosberg, 1948; Gressitt, 1963; Carlquist, 1974; Berger, 1981; Wagner et al., 1990). The sequential origin of the islands, coupled with their considerable size and isolation, makes the Hawaiian archipelago a unique place to investigate biological evolutionary history.

Because of their hot spot origin, the Hawaiian Islands are like a giant habitat conveyor belt. New volcanoes arise out of the ocean bare and available for any life that can reach them and survive. After the cessation of volcanic activity, the history of a volcanic island is one of constant erosion and subsidence. The wide sloping sides and alpine habitats of the young islands give way to the knife-edge ridges, steep slopes, and deep valleys of the older islands. Species that are specialized for the habitats of young volcanoes must move on to new volcanoes or give rise to species that can inhabit the new environment created by erosion and subsidence of older volcanoes. Eventually, an island erodes and subsides to a size where there are no longer alpine areas and wet forest, and only relatively dry coastal habitats remain.

Most multiple-island distributions are the result of dispersal between islands. However, vicariance patterns are possible within clades (monophyletic groups) or grades (paraphyletic groups) either on individual islands or among volcanoes that have been connected in the past, especially on Maui Nui. For instance, on each island that has more than one species of a lineage and whose species are the result of a single introduction, the intra-island pattern may be the result of vicariance. Erosion during the posteruptional stage of an island could dissect previously continuous species distribution into geographically discontinuous population mosaics. Another possibility for vicariance involves the four current islands that made up Maui Nui. A vicariant pattern resulting from the breakup of Maui Nui would not necessarily exhibit any correlation with island age. This would be the case in the separation and isolation of populations of a widespread species, followed by speciation in the isolates. Thus, absence of resolution on the area cladogram among the taxa of the islands that made up Maui Nui may be the result of vicariance. To document vicariance, repeating patterns must be detected within unrelated clades either within a single island or among the islands of the Maui Nui complex.

Using the phylogenies and area cladograms in this volume (Table 17.1), we seek to investigate the following questions: How many different biogeographic patterns were found? Are any of these patterns

TABLE 17.1. List of Genera and Lineages Discussed, and the Contributors

Taxon	Contributor(s)
Insects	
<i>Drosophilidae</i> (fruit flies)	DeSalle; Kaneshiro et al.
<i>Laupala</i> (crickets)	Shaw
<i>Prognathogryllus</i> (crickets)	Shaw
<i>Sarona</i> (true bugs)	Asquith
Spiders	
<i>Tetragnatha</i> (spiders; two lineages)	Gillespie and Croom
Birds	
Drepanidinae (honeycreepers)	Tarr and Fleischer
Flowering plants	
<i>Clermontia</i> (Campanulaceae)	Lammers
<i>Cyanea</i> (Campanulaceae)	Givnish et al.
<i>Dubautia</i> , <i>Wilkesia</i> and <i>Argyroxiphium</i> (Asteraceae)	Baldwin and Robichaux; Funk and Wagner
<i>Geranium</i> (Geraniaceae)	Funk and Wagner
<i>Hesperomammia</i> (Asteraceae)	Funk and Wagner
<i>Hibiscadelphus</i> (Malvaceae)	Funk and Wagner
<i>Kokia</i> (Malvaceae)	Funk and Wagner
<i>Platydesma</i> (Rutaceae)	Funk and Wagner
<i>Remya</i> (Asteraceae)	Funk and Wagner
<i>Scaevola</i> (Goodeniaceae)	Patterson
<i>Schiedea</i> and <i>Alsinidendron</i> (Caryophyllaceae)	Wagner et al.
<i>Tetramolopium</i> (Asteraceae)	Lowrey

consistent with one another? Are the patterns consistent with a priori hypothetical patterns? Is speciation generally inter- or intra-island?

The answers to these particular questions may provide insights for answering the more general question of whether the evolutionary history of the Hawaiian biota mirrors the geologic history of the islands.

METHODS

Standard phylogenetic methods were used to analyze the data for the 25 lineages presented in this volume. Kaneshiro et al. (Chapter 5) used species groups rather than individual species as the terminal taxa, and their results are less directly comparable with other studies in this volume.

An overview of the phylogenetic methodology is presented earlier in this volume (Chapter 3). For this chapter, the cladograms were generated using the computer program PAUP version 3.1.1 (Swofford, 1993). With a few minor exceptions, the cladograms produced were identical to those generated by the contributors; differences that were found did not affect any biogeographic conclusions. Individual cladograms were converted to area cladograms by replacing the terminal taxa with their geographic distribution.

To avoid ambiguity, we refer to the situation of multiple species making up a clade or grade on the same island as "intra-island radiation," or simply "radiation." Inter-island colonization is referred to as "dispersal."

Optimization was used to determine the island of origin of the ancestors of several lineages (Chapter 3). Although this method can be informative, it does have limitations and problems. For example, optimization designates the possible island of origin of the ancestor of the base of the extant clade; such information cannot be used to determine whether the lineage occurred earlier on an older, now-eroded island. There are also some instances in which optimization cannot give an answer, most notably when each island has only one species of a clade. Finally, species that have dispersed to other islands without speciation create problems for optimization by making it difficult to determine the island on which the speciation event took place. This problem is not restricted to optimization on island studies, because widespread species create problems for all biogeographic studies regardless of the method or location.

We established several hypothetical patterns that reflect the expected area cladogram for different presumed evolutionary histories. The actual area cladograms of the endemic lineages were compared with the hypothetical area cladograms to determine which, if any, of the hypothetical patterns were supported by the data. When originally formulating our hypothetical patterns, we underestimated the amount of intra-island radiation and therefore found it necessary to increase its importance by adding two patterns after the analysis began.

The hypothetical patterns can be divided into two basic groups: simple patterns and complex patterns. A subset of one complex pattern is discussed in more detail separately as younger island patterns. Basic attributes of the patterns and their accompanying evolutionary implications are described below.

BASIC PATTERNS

Progression Rule

Previously the progression rule (Hennig, 1966; Wiley, 1981) was used to compare the cladogram and the distribution pattern and did not involve the geologic history of the area. As used here, it is necessary that the ancestor of the clade arrived on what is now the oldest high island, Kaua'i, when it was young, either from outside the Hawaiian Islands or from an older, now-submerged or eroded island, and as each new volcano became available for colonization, a dispersal event associated with speciation occurred from the older to the younger volcano. The area cladogram resulting from this hypothesis is a ladderlike progression involving the volcanoes of the six main high islands (Figure 17.1). For any taxon, if only one species evolved on each successive volcano and if none of the species became widespread, then the area cladogram would be consistent with this pattern. Not all the islands have to be involved, but for those that are, the branching sequence on the area cladogram would be consistent with this pattern. If such an area cladogram were optimized for the distribution, the result would be inconclusive because there is only one species per volcano.

FIGURE 17.1. Hypothetical progression rule pattern. OG, outgroup.

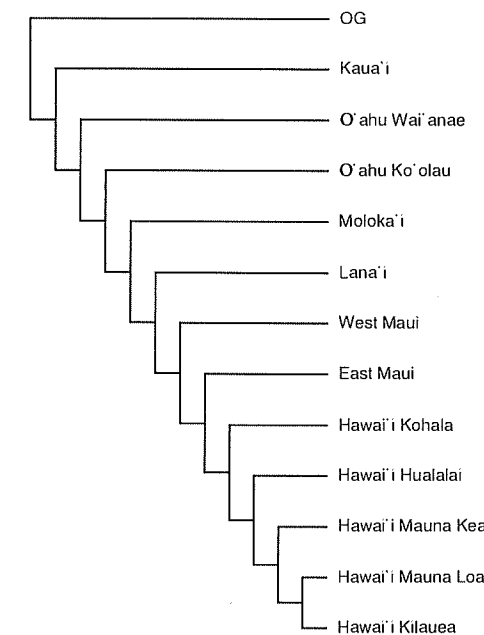

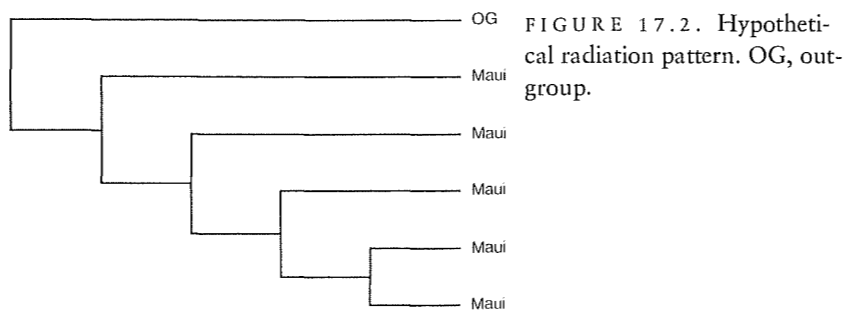

FIGURE 17.2. Hypothetical radiation pattern. OG, outgroup.

Radiation

A taxon arrives and radiates on an island, thus all speciation is intra-island. If the original dispersal occurred on Maui and speciation occurred without any inter-island dispersal, then the pattern shown in Figure 17.2 would result.

Unresolved

An unresolved pattern (Figure 17.3) could be created in at least two ways: by repeated dispersal of a single species to several islands before any speciation, or by repeated dispersal from an older, now-severely eroded and subsided island by several members of the same clade with loss of all the unique identifying characters of those species. An unresolved pattern must be viewed with caution, however, because it could result from insufficient data to resolve the members of the clade.

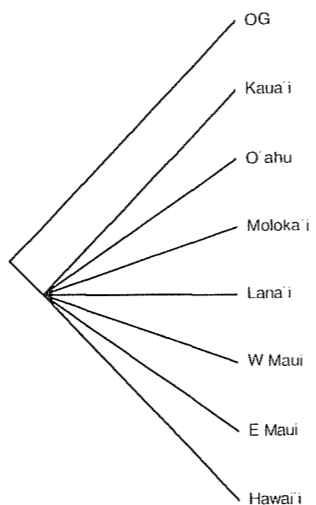
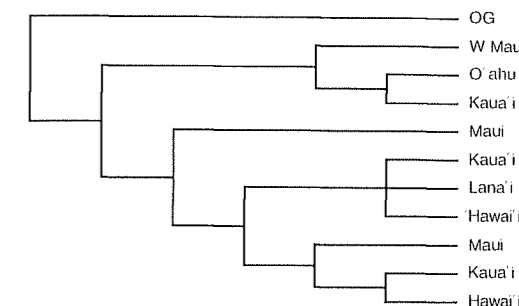

FIGURE 17.3. Hypothetical unresolved pattern. OG, outgroup.

FIGURE 17.4. Hypothetical stochastic pattern. OG, outgroup.



Stochastic

A cladogram of a lineage exhibiting a stochastic pattern would have a branching sequence, but the pattern of the area cladogram would not follow any known historical events. One explanation for this situation is that the species of a clade display extreme vagility, and the scale of their ability to colonize goes well beyond typical inter-island distances. Another explanation would entail random colonization and speciation; recency of introduction may also be a factor. A lineage that is relatively recent to the archipelago may be colonizing adjacent islands in a random fashion. The resulting area cladogram associated with any of these explanations would not have an obvious correlation with the geologic history of the islands. The clades presented in Figure 17.4 show examples of several possibilities for this scenario.

Back-Dispersal

An area cladogram of a lineage exhibiting back-dispersal would indicate that after a species is established on an island, it then disperses to an older island followed by speciation, in which case a progression pattern is interrupted. Such an event is illustrated in Figure 17.5, where a back-dispersal accompanied by speciation has taken place from East Maui to Kaua'i.

FIGURE 17.5. Hypothetical back-dispersal pattern. The example illustrates a back-dispersal from East Maui to Kaua'i. OG, outgroup.

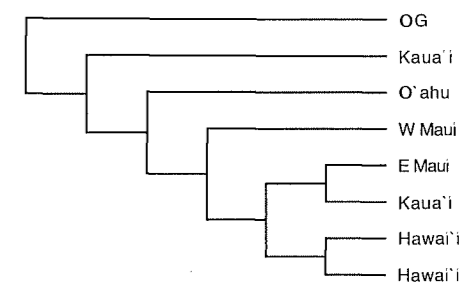

COMBINED PATTERNS

Progressive Clades and Grades

If a lineage has multiple species on one or more islands resulting from a single introduction, the area cladogram can consist of clades (Figure 17.6), grades (Figure 17.7), or various combinations of the two. What topologies can be formed depends on the position in the evolutionary history of the group occupied by the inter-island colonist. Figures 17.8A, 17.9A, and 17.10A show radiation of the same taxa on the same three islands, each clade of nine species representing the species of an endemic genus. Different cladograms (Figures 17.8B, 17.9B, and 17.10B) and area cladograms (Figures 17.8C, 17.9C, 17.10C) are produced, depending on which taxon (from different phylogenetic positions of the clade) is the colonist to the new island. If dispersal to a new island occurs early in the evolutionary history of an extant clade (Figure 17.8A), the result is a progressive clade pattern (Figure 17.8B and C). In contrast, Figure 17.9A shows a colonist from a terminal taxon of the extant clade, so the cladogram (Figure 17.9B) and the area cladogram (Figure 17.9C) are ladderlike, forming progressive grades, except for the clade on the island

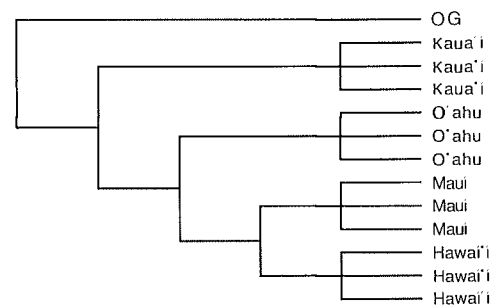

FIGURE 17.6. Hypothetical progressive clades pattern. OG, outgroup.

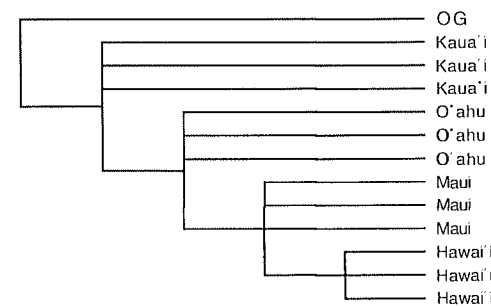

FIGURE 17.7. Hypothetical progressive grades pattern. OG, outgroup.

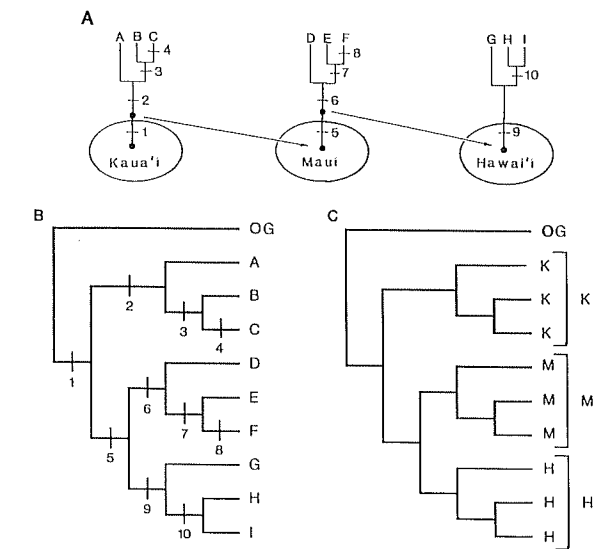

FIGURE 17.8. Hypothetical inter- and intra-island radiation that would produce a progressive clades pattern. (A) Schematic illustration of radiation; (B) cladogram for the schematic; (C) corresponding area cladogram. OG, outgroup; K, Kaua'i; M, Maui; H, Hawai'i.

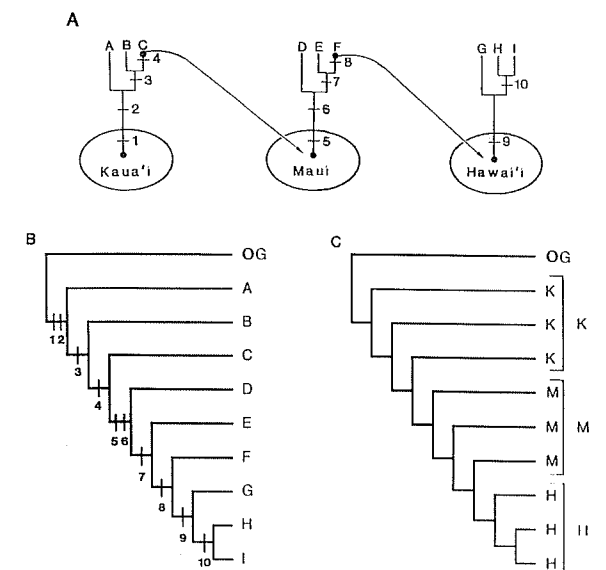

FIGURE 17.9. Hypothetical inter- and intra-island radiation that would produce a progressive grades pattern. (A) Schematic illustration of radiation; (B) cladogram for the schematic; (C) corresponding area cladogram. OG, outgroup; K, Kaua'i; M, Maui; H, Hawai'i.

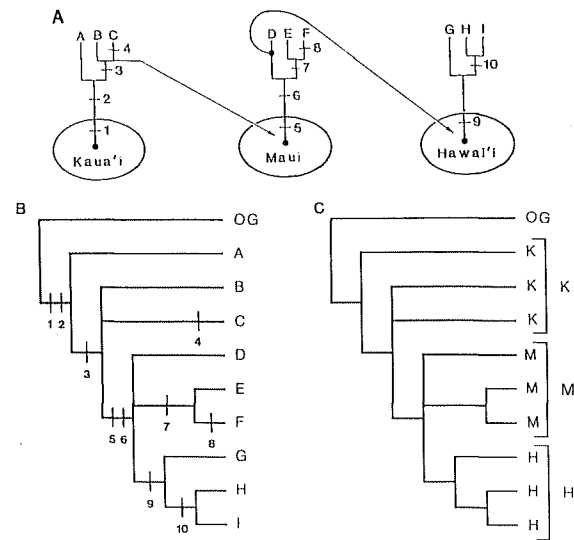

FIGURE 17.10. Hypothetical inter- and intra-island radiation that would produce a mixed pattern. (A) Schematic illustration of radiation; (B) cladogram for the schematic; (C) corresponding area cladogram. OG, outgroup; K, Kaua'i; M, Maui; H, Hawai'i.

of Hawai'i, which has not dispersed to a new island. The colonists in Figure 17.10A are from two different intermediate positions in the clade, and the resulting cladogram (Figure 17.10B) and area cladogram (Figure 17.10C) are a combination of clades, grades, and unresolved nodes. Although a wide variety of patterns is possible, all share a common feature in that species from a particular island are grouped together in a clade or grade, and the overall pattern of the area cladogram is consistent with the progression rule. Although there is speciation within and between islands, the overall pattern is one of progression from oldest to youngest island within a lineage. In the next combined pattern, the overall inter-island pattern is not so obvious.

Terminal Resolution

A terminal resolution pattern exhibits several well-defined clades as subpatterns and either an unresolved base or a base that has experienced a radiation on an older island. The subpatterns are either progressions or radiations. Both of these possibilities indicate repeated introductions from an older, now-severely eroded or submerged island. The first,

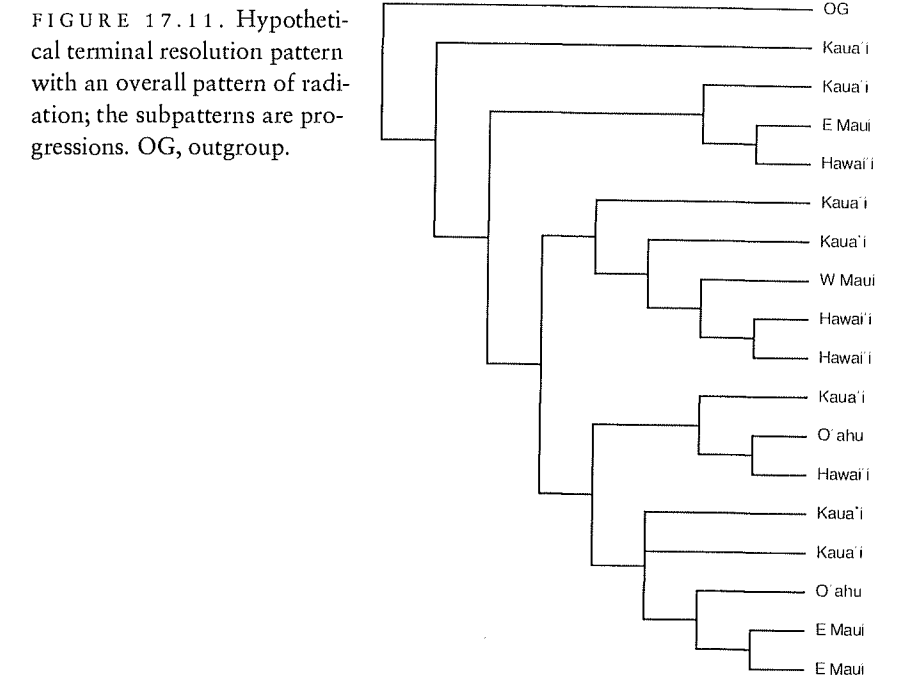

FIGURE 17.11. Hypothetical terminal resolution pattern with an overall pattern of radiation; the subpatterns are progressions. OG, outgroup.

shown in Figure 17.11, exhibits a grade as the basic pattern, indicating that the origin of the clade is a radiation on that island (in this case, Kaua'i) or that the ancestors of the extant species dispersed from an older island and the descendent species have retained enough of the characters of their ancestors to preserve the relationship structure of the cladogram. In Figure 17.11, the subpatterns are progressions, but some could involve radiations.

The second case is shown in Figure 17.12. It demonstrates an unresolved base, indicating that the lineage experienced repeated dispers-

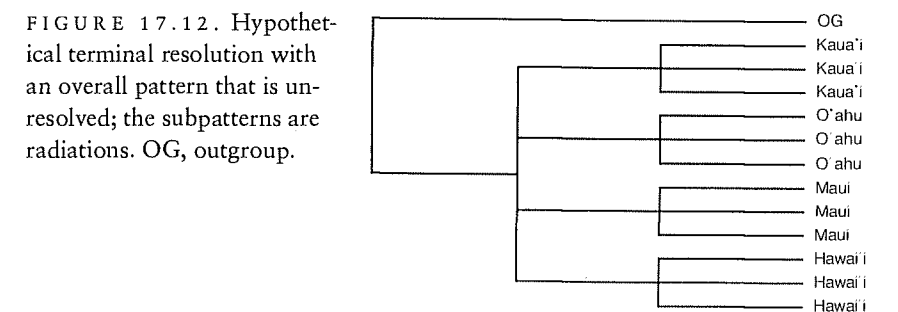

FIGURE 17.12. Hypothetical terminal resolution with an overall pattern that is unresolved; the subpatterns are radiations. OG, outgroup.

als from the same or a very similar ancestor or that the characters that separated the ancestral species from one another have been lost. Although the colonists to the current high islands from now-submerged or severely eroded older islands were not necessarily from the same species, they were all members of the same lineage, and because the ancestors are now extinct, the lineage is now a single clade. In Figure 17.12, the subpatterns are radiations, but they could also be progressions.

Most of the patterns described above reflect evolutionary scenarios that depict an older-to-younger island colonization. There also are patterns that center on younger islands. These have different interpretations than those involving colonization from older to younger islands.

YOUNGER ISLAND PATTERNS

Recent Colonization

If a taxon arrived in the Hawaiian Islands directly onto one of the current eight high islands while that island was young, the resulting pattern might reflect a combination of dispersal events from younger to older islands in a random or unresolved pattern and, at the same time, develop a ladderlike progression for species that arise as new islands emerge. Figure 17.13 shows results of a colonization on East Maui when it was the youngest island in the chain. After successful colonization, the species dispersed to Moloka'i. It also underwent radiation on East Maui, with one species dispersing to O'ahu and another eventually dispersing to Hawai'i to form a progression for the terminal three species of the lineage. If speciation occurred on East Maui before any dispersal, the taxa resulting from the dispersal events to the older islands would be nested within the East Maui clade. By contrast, if the colonist were a recent

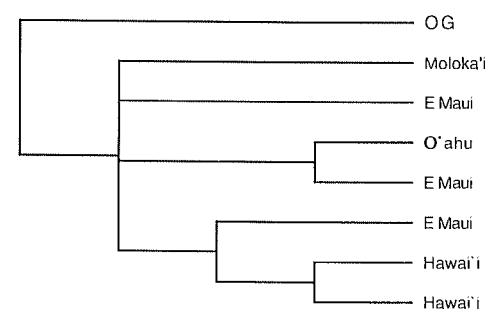

FIGURE 17.13. Hypothetical younger island pattern showing recent colonization. OG, outgroup.

arrival, there would be only the dispersal part of the area cladogram mentioned above.

Extinction

If a taxon is specific to habitats found only on younger islands, the loss of such habitats with erosion and subsidence on increasingly older islands would cause the diversity of the area cladogram to shift continually to the younger islands. As a result, area cladograms could be either progressions or radiations but would not include any of the older islands even though the lineage was once present on these islands (Figure 17.14). Can this pattern be distinguished from one of a clade that colonized one of the younger islands and has not back-dispersed along the chain?

One way to differentiate between these two patterns is to assess the amount of change that has taken place between the Hawaiian lineage and the most closely related group outside the archipelago. East Maui was formed only 0.75 Ma, so if a lineage had its origin on East Maui, all the observed diversity would have evolved less than 0.75 Ma. Another way to differentiate between these two patterns would be to examine the geographic occurrences of the habitats to which the species of the lineage are restricted. For example, subalpine and young lava flow habitats have been lost on the older islands, presumably along with any species associated with these environments. Some consideration should be given to the likelihood of an extinction pattern in any lineage restricted to young islands.

The patterns described in the above section were designed to predict the type of area cladogram that would result if certain types of evolutionary histories had occurred. The actual cladograms from the other chapters must be compared with the hypothetical ones to determine if any of the latter are supported.

FIGURE 17.14. Hypothetical younger island pattern showing extinction in the basal taxa of the lineage, with extinction indicated by a question mark. OG, outgroup.

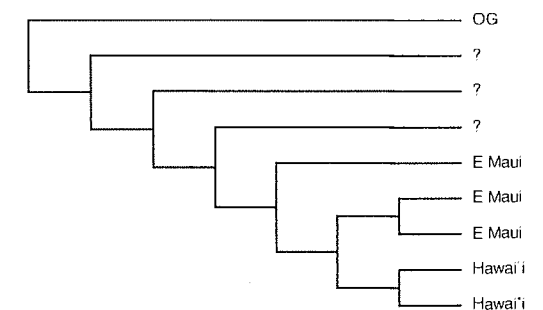

SEARCH FOR COMMON PATTERNS

This section examines the results of each data chapter included in this volume. To directly compare the phylogenetic information relevant to biogeographic interpretations from the various chapters, we present an area cladogram for each lineage in a uniform style without any extraneous information other than the branching sequence. We begin with the simplest of the area cladograms and move to the increasingly more complex examples. A question mark on a figure usually indicates there is more than one equally parsimonious way to distribute the islands at that point on the area cladogram. An asterisk indicates that a particular group of taxa forms a grade on the area cladogram; all other groups are indicated monophyletic. Colonization patterns are indicated in the text by island abbreviations (K, Kaua'i; O, O'ahu; Mo, Moloka'i; L, Lana'i; EM, East Maui; WM, West Maui; M, Maui; MN, the Maui Nui complex; H, Hawai'i) connected by an arrow indicating direction of colonization.

Hawaiian Drosophilidae (Kaneshiro, Chapter 5; DeSalle, Chapter 6)

The general area cladogram of the sampled *Drosophila* lineages by DeSalle (Chapter 6) exhibits the progression rule pattern. Moreover, the analysis showed that each of the six clades (Figure 17.15) were consistent with the progression rule pattern with a few progressive clades and grades and that all were consistent with an overall pattern of colonization from older to younger islands (O → Mo → WM → EM → H) following the progression rule. Because each of the sublineages is a part of the larger Drosophilidae clade, there is an overall pattern to consider. We do not know how all these clades in the Hawaiian Islands are related to each other; however, it seems likely that the overall pattern would be terminal resolution because the subpatterns of component lineages represent progressions.

The Drosophilidae were also discussed by Kaneshiro et al. (Chapter 5). Because the terminal taxa in their study were species groups rather than individual species, it is difficult to compare the results here. However, most of the *Drosophila* clades have members on two or more islands, and the biogeographic pattern is consistent with the results of DeSalle's analyses in that each lineage of flies he examined had an inter-island distribution pattern, rather than a radiation on a single island. Among the 29 terminal taxa in Kaneshiro's cladogram, only 6 of the nonbasal ones have species on Kaua'i. This also agrees with DeSalle's findings; all six of his clades were distributed from O'ahu to the younger

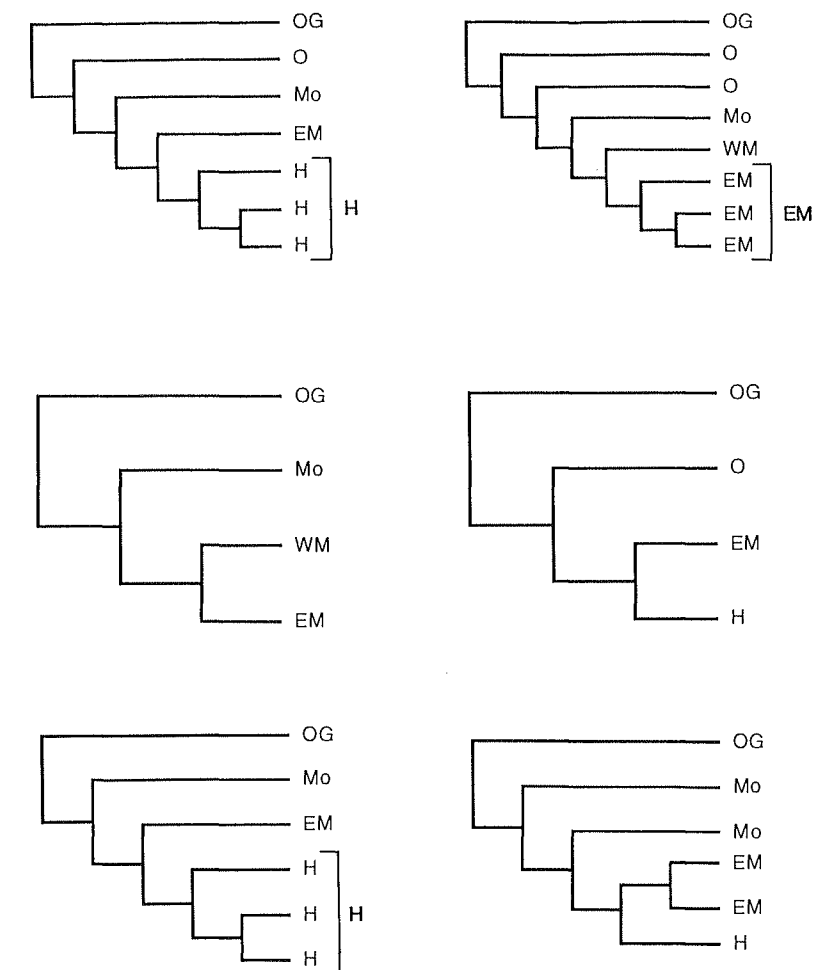

FIGURE 17.15. Area cladograms for the six clades of Hawaiian *Drosophila* data from DeSalle (Chapter 6). OG, outgroup; O, O'ahu; Mo, Moloka'i; WM, West Maui; M, Maui; EM, East Maui; H, Hawai'i.

islands, and none of them had species on Kaua'i. Three of the basal groups, however, occur on Kaua'i, so when the area cladogram is optimized, it gives a Kaua'i ancestor for the entire clade.

Remya, *Hesperomannia*, and *Kokia* (Funk and Wagner, Chapter 10)

Remya and *Hesperomannia* are small Asteraceae genera that exhibit patterns consistent with the progression rule (Figure 17.16A and B). A

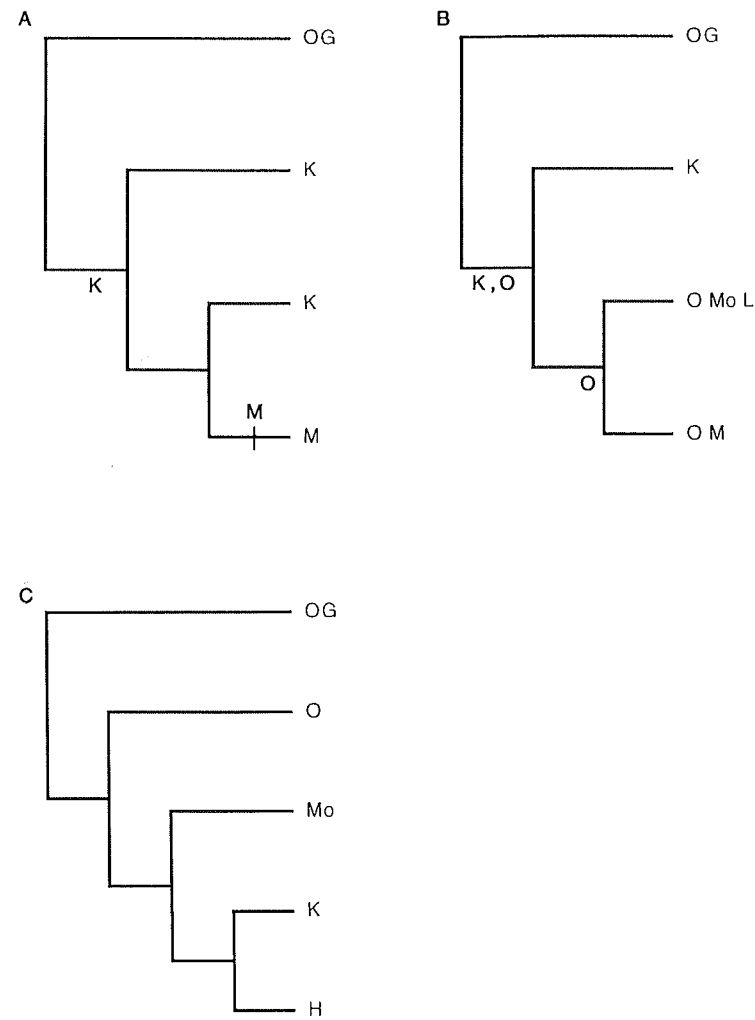
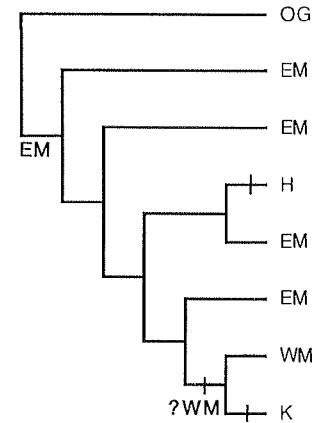

FIGURE 17.16. Area cladograms for three genera of flowering plants, data from Funk and Wagner (Chapter 10). (A) *Remya*; (B) *Hesperomannia*; (C) *Kokia*. OG, outgroup; K, Kaua'i; O, O'ahu; Mo, Moloka'i; L, Lana'i; M, Maui; H, Hawai'i.

Kaua'i ancestor is unambiguously indicated for *Remya*, whereas the situation in *Hesperomannia* is equivocal, with either a Kaua'i or an O'ahu ancestor. The area cladogram of *Kokia* (Malvaceae) (Figure 17.16C) is more complicated. It is consistent with two patterns: The overall pattern is compatible with the progression rule, with the compounding hypothesis

FIGURE 17.17. Area cladogram for *Geranium* section *Neurophyllodes*, data from Funk and Wagner (Chapter 10). It is equally parsimonious to hypothesize a Kaua'i or West Maui origin for the terminal two-taxa clade, indicated by the question mark. OG, outgroup; K, Kaua'i; WM, West Maui; EM, East Maui; H, Hawai'i.



of a single back-dispersal to Kaua'i. As mentioned earlier, and as demonstrated with *Drosophila* and *Kokia*, optimization is not an effective tool when there is only one species per island.

Geranium Section *Neurophyllodes* (Funk and Wagner, Chapter 10)

The endemic Hawaiian geraniums show a radiation pattern with the clade on East Maui (Figure 17.17). Most of the speciation events are associated with the radiation, but three dispersal events are associated with speciation, involving a dispersal to Hawai'i (progression rule) and two cases of back-dispersal, one each to Kaua'i and West Maui. The Hawaiian shrubby *Geranium* lineage is well defined and unique in many ways from extra-Hawaiian *Geranium*. Because the basal Hawaiian species occur in subalpine habitats, this lineage may represent an example of habitat loss and associated extinction so that although the current clade apparently originated on East Maui, the age of the lineage in the archipelago could be much older, in which case now-extinct species would have existed on islands that once had subalpine habitat.

Drepanidinae (Tarr and Fleischer, Chapter 9)

The area cladogram of the honeycreeper species that were sampled shows an equivocal base of either Maui or Kaua'i (Figure 17.18). However, the position of the basal taxon on the cladogram is in doubt (see Tarr and Fleischer, this volume, Chapter 9). Leaving out this basal taxon and starting one branch up from the base, the distribution shows a Kaua'i origin and radiation followed by dispersal to other islands. However, not

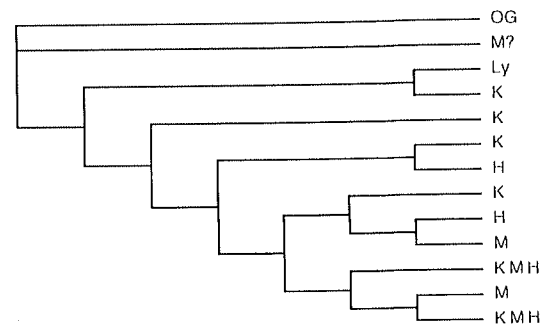

FIGURE 17.18. Area cladogram for some species of the Hawaiian Drepanidinae, data from Tarr and Fleischer (Chapter 9). OG, outgroup; Ly, Laysan; K, Kaua'i; M, Maui; H, Hawai'i; the *question mark* indicates that the placement of this taxon is in question.

all the extant honeycreeper taxa have been included in the study. Furthermore, several additional species of *Telespiza* from Kaua'i, O'ahu, Moloka'i, and Maui are known only from fossils (Olson and James, 1982b; James and Olson, 1991). This shows that many honeycreeper taxa were once more widespread and that the vagility of the honeycreeper lineage exceeds that of most of the other taxa considered in this volume. Their area of easy dispersal is great enough that the scale on which they differentiate geographically exceeds the inter-island distances between the Hawaiian volcanoes, creating a stochastic pattern.

Hibiscadelphus (Funk and Wagner, Chapter 10)

The area cladogram for *Hibiscadelphus* (Figure 17.19) shows a basic progressive clades and grades pattern, with a two-taxa grade on both Kaua'i and the Maui Nui complex and a terminal clade on the island of Hawai'i. When the distribution is optimized on the cladogram, it indicates a Kaua'i ancestor for the clade and an inter-island dispersal pattern of $K \rightarrow MN \rightarrow H$.

Prognathogryllus and *Laupala* (Shaw, Chapter 4)

The two area cladograms of crickets have different specific patterns, but they are of the same type. The first one, for *Prognathogryllus* (Fig-

FIGURE 17.19. Area cladogram for *Hibiscadelphus*, data from Funk and Wagner (Chapter 10). OG, outgroup; K, Kaua'i; MN, Maui Nui complex; H, Hawai'i; an *asterisk* denotes a group of taxa that form a grade, and all other groups are clades.

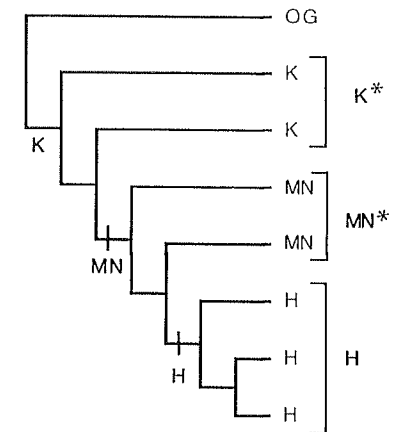

ure 17.20), exhibits an overall pattern of progressive clades and grades. Progressive clades and grades are on Kaua'i and O'ahu, followed by two sister clades; one indicates a radiation on Hawai'i with a back-dispersal to O'ahu, whereas the other suggests a radiation on Maui with a dispersal to Hawai'i and a back-dispersal to O'ahu. When the distribution is optimized on the area cladogram, a Kaua'i ancestor and a $K \rightarrow O \rightarrow M \rightarrow H$ dispersal pattern are indicated. The second genus, *Laupala* (Figure 17.21), also shows a combination of progressive clades and grades with radiation patterns on Kaua'i, O'ahu, Maui, and Hawai'i. However, when optimized one dispersal pattern is from $K \rightarrow O$, whereas the other is a $K \rightarrow M \rightarrow H$. In the Hawai'i clade, there are two cases of back-dispersal to Maui. The overall colonization pattern of both genera is dispersal from older to younger islands.

Hawaiian *Tetragnatha* (Gillespie and Croom, Chapter 8)

Two separate lineages of *Tetragnatha* were studied. The area cladograms appear somewhat different from those of Gillespie and Croom only because in this analysis subspecific taxa were combined so that all terminal taxa were species. The actual branching sequence for the species is identical to that in Gillespie and Croom. The area cladogram of the *elongate* clade (Figure 17.22) shows a progressive clades and grades pattern, with a grade on the Maui Nui complex and a clade on Hawai'i. This is followed by a back-dispersal pattern with dispersal from the island of Hawai'i clade to Kaua'i and East Maui. The overall pattern of coloni-

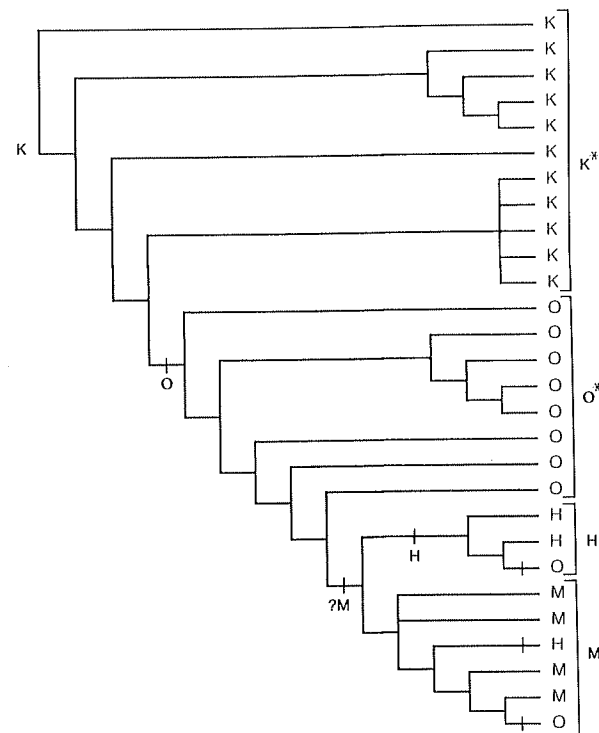

FIGURE 17.20. Area cladogram for *Prognathogryllus*, data from Shaw (Chapter 4). There are three equally parsimonious ways to arrange the areas for the two terminal clades. The one illustrated agrees with the progression rule. K, Kaua'i; O, O'ahu; M, Maui; H, Hawai'i; the *question mark* indicates there is more than one equally parsimonious way to distribute the islands at that point on the area cladogram; an *asterisk* denotes a group of taxa that form a grade, and all other groups are clades.

zation is $K \rightarrow MN \rightarrow H$, which is consistent with the older-to-younger island sequence. There is also some indication of a vicariant pattern for some taxa within the Maui Nui complex.

The patterns of the two sister clades of the *Tetragnatha spiny leg* lineage are less obvious than that of the *elongate* clade mentioned above. Both of the *spiny leg* clades show a basal group on Kaua'i and a clade that radiated on Maui and are therefore consistent with the progression rule, older-to-younger island pattern. One *spiny leg* clade (Figure 17.23A) is consistent with a $K \rightarrow EM$ dispersal pattern with two independent cases

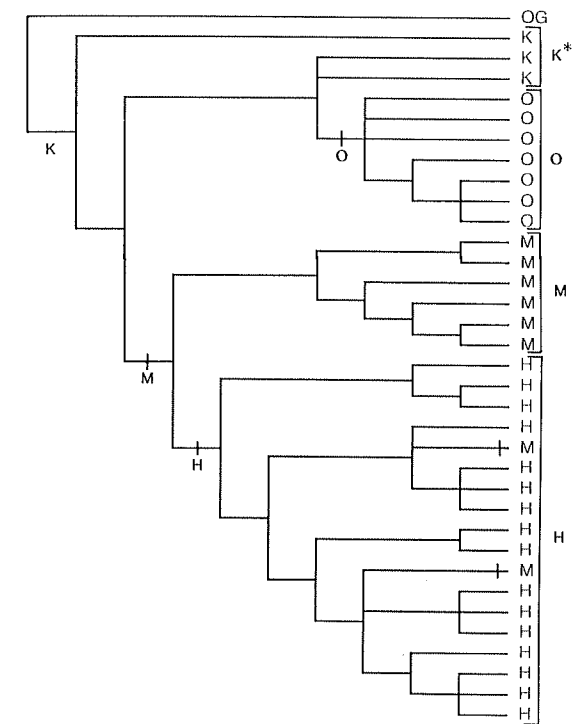

FIGURE 17.21. Area cladogram for *Laupala*, data from Shaw (Chapter 4). There are three equally parsimonious ways to arrange the areas for the two terminal clades. The one illustrated agrees with the progression rule. OG, out-group; K, Kaua'i; O, O'ahu; M, Maui; H, Hawai'i; an *asterisk* a group of taxa that form a grade, and all other groups are clades.

of back-dispersal to O'ahu. The other *spiny leg* clade (Figure 17.23B) is consistent with a $K \rightarrow O \rightarrow M$ dispersal pattern, but both are unresolved to some extent. Perhaps this is because the *spiny leg* species are less sedentary than members of the *elongate* clade.

Silversword Alliance (Funk and Wagner, Chapter 10; Baldwin and Robichaux, Chapter 13)

The three genera of the silversword alliance, *Argyroxiphium*, *Dubautia*, and *Wilkesia*, have been analyzed using molecular data (see this volume, Chapter 13), and the former two genera have been analyzed using morphological data (see this volume, Chapter 10). The molecular analysis is

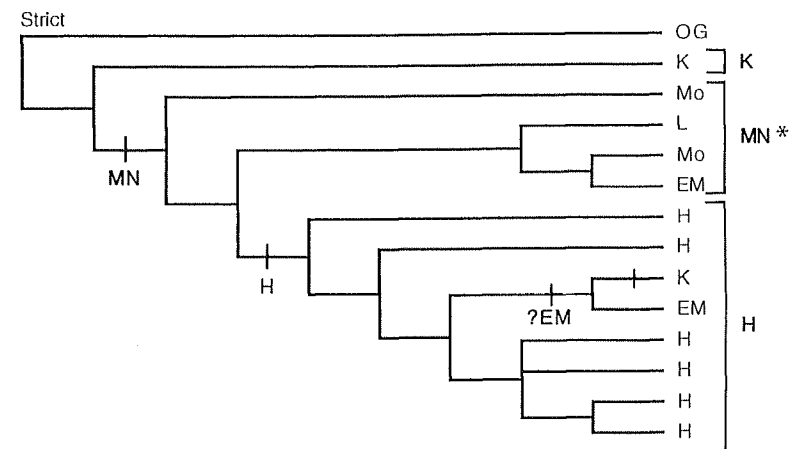

FIGURE 17.22. Area cladogram for *Tetragnatha*, the *elongate* clade, data from Gillespie and Croom (Chapter 8). OG, outgroup; K, Kaua'i; Mo, Moloka'i; L, Lana'i; EM, East Maui; H, Hawaii'i; the *question mark* indicates there is more than one equally parsimonious way to distribute the islands at that point on the area cladogram; an *asterisk* denotes a group of taxa that form a grade, and all other groups are clades.

more complete (Figure 17.24), with the inclusion of many more taxa from *Dubautia*, whereas the morphological study (Figure 17.25) used each of the three sections of *Dubautia*. The area cladogram based on molecular data is somewhat different from that of Baldwin and Robichaux only because in this analysis subspecific taxa were combined so that all terminal taxa were species.

Both the morphological and molecular analyses showed that *Argyroxiphium*, *Wilkesia*, and *Dubautia* section *Railliardia* were monophyletic. Further, they indicated that *Dubautia* section *Dubautia* was non-monophyletic. The third section of *Dubautia* is monotypic. There are two basic differences in the area cladograms, only one of which affects the biogeographic interpretation. The first is the placement of three species of *Dubautia* as the sister group of the two species of *Wilkesia* in the molecular tree (Figure 17.24). Because all five species involved occur on Kaua'i, the biogeographic results are not affected. The second difference involves the sister-group relationship between *Argyroxiphium* and *Wilkesia*. In the morphological analysis, these two genera are sister taxa, whereas the molecular data place *Argyroxiphium* as the sister taxon to

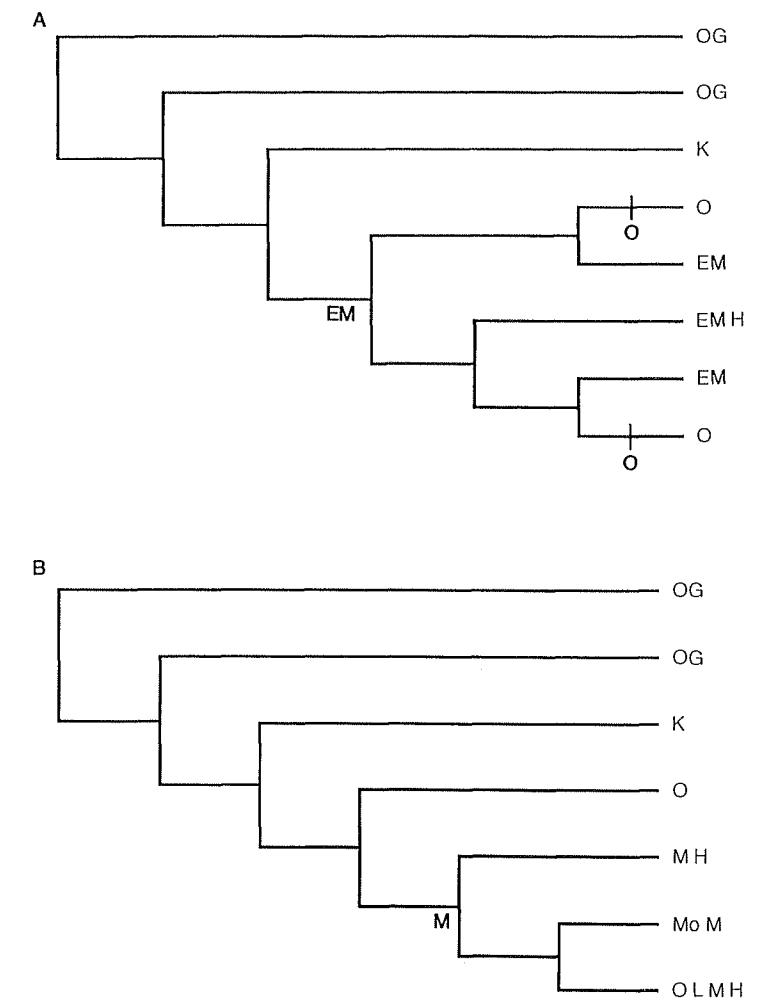

FIGURE 17.23. Area cladograms for *Tetragnatha*, data from Gillespie and Croom (Chapter 8). (A) *Spiny leg* clade 1; (B) *spiny leg* clade 2. OG, outgroup; K, Kaua'i; O, O'ahu; Mo, Moloka'i; L, Lana'i; M, Maui; EM, East Maui; H, Hawaii'i.

the group consisting of *Wilkesia* and *Dubautia*. As a result, the island of origin of the silversword alliance is unambiguously Kaua'i based on the morphology data, whereas it is either Kaua'i or Maui based on the molecular data. Based solely on the molecular area cladogram, a Kaua'i or older island origin for the group is still preferred by Baldwin and Robichaux (Chapter 13). The morphology area cladogram exhibits a

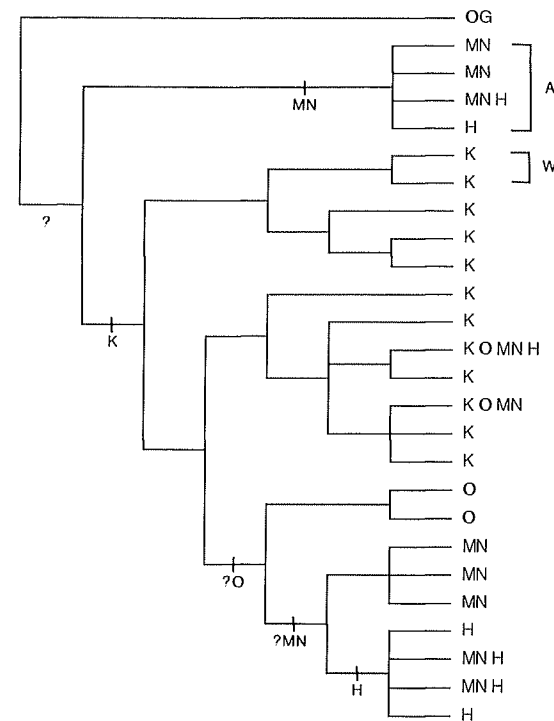
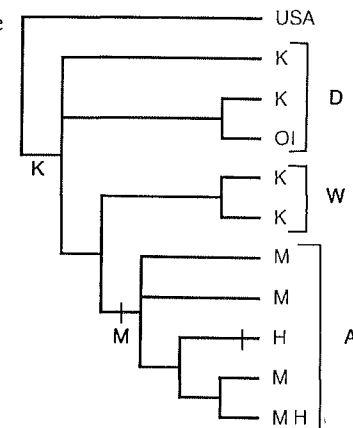

FIGURE 17.24. Area cladogram for the silversword alliance based on molecular data from Baldwin and Robichaux (Chapter 13). A, *Argyroxiphium*; W, *Wilkesia*; all remaining taxa are species of *Dubautia*. OG, outgroup; K, Kaua'i; O, O'ahu; MN, Maui Nui complex; H, Hawai'i; a question mark indicates there is more than one equally parsimonious way to distribute the islands at that point on the area cladogram.

FIGURE 17.25. Area cladogram for the silversword alliance based on morphological data from Funk and Wagner (Chapter 10). USA, continental United States (outgroup); A, *Argyroxiphium*; D, *Dubautia*; W, *Wilkesia*; OI, islands other than Kaua'i; K, Kaua'i; M, Maui; H, Hawai'i.



progressive clades and grades pattern, including two radiations, one on Kaua'i in *Wilkesia* and one on East Maui in *Argyroxiphium*.

In the molecular area cladogram, one can separate *Argyroxiphium* and the remainder of the area cladogram, producing two different patterns. The *Dubautia* and *Wilkesia* clade shows a definite progressive clades and grades pattern with a Kaua'i base and an overall pattern consistent with a K → O → MN → H dispersal pattern. *Argyroxiphium*, however, expresses a radiation pattern, with Maui as its base. *Argyroxiphium* is confined to habitats that do not exist on any of the older islands; thus, like *Geranium*, *Argyroxiphium* may be an example of an extinction pattern. Like the morphological data, the molecular data show a Kaua'i radiation for *Wilkesia* and an East Maui radiation for *Argyroxiphium*.

Schiedea and *Alsinidendron* (Wagner et al., Chapter 12)

Although there were six equally parsimonious trees, the differences among them involved minor changes that did not alter the biogeographic analysis. The area cladograms indicate a Kaua'i origin for three of the extant *Schiedea* and *Alsinidendron* clades with either a Kaua'i or O'ahu origin for the *S. globosa* clade (Figure 17.26). The terminal three clades each had their origin on Kaua'i, but rather than showing radiations on a single island, each clade dispersed to the younger islands of O'ahu and the Maui Nui complex with some indication of a vicariant pattern within the complex. The only species occurring on the island of Hawai'i is widespread and is found on Moloka'i and Maui as well. The area cladogram fits the terminal resolution pattern, with an overall pattern of a radiation on Kaua'i followed by dispersal first to O'ahu and then to the islands of the Maui Nui complex. This apparent radiation on Kaua'i may be the result of dispersal from an older island. If the cladograms produced in this analysis represent the actual phylogeny, repeated independent colonizations took place from an older island to the younger island of Kaua'i. Therefore, if we eliminate the Kaua'i taxa, the hypothetical location of the ancestor should shift to O'ahu. When we remove the Kaua'i taxa from the area cladogram, it shows that the lineage has four clades, each with an origin on O'ahu (Figure 17.27). The two terminal clades (see Figure 17.26) each have widespread species as terminal taxa, and these are the only widespread species in the genus. Perhaps this is an example of the way such lineages evolve—terminal taxa dispersing to younger islands followed by allopatric speciation and radiation.

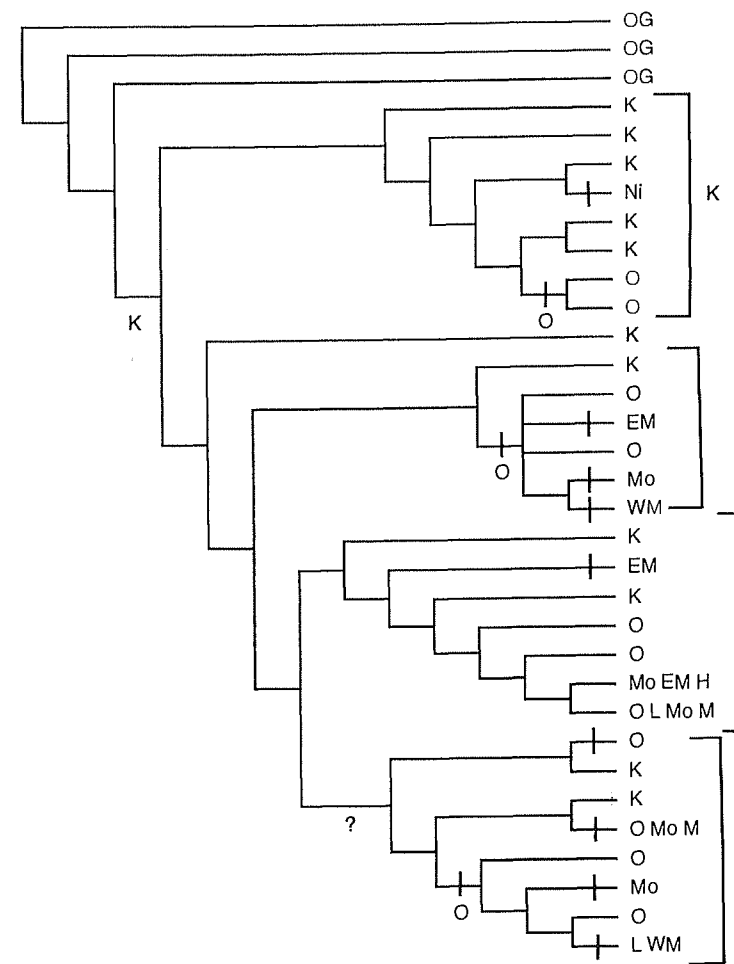

FIGURE 17.26. Area cladogram for *Schiedea* and *Alsinidendron*, data from Wagner et al. (Chapter 12). OG, outgroup; K, Kaua'i; Ni, Nihoa; O, O'ahu; Mo, Moloka'i; L, Lana'i; WM, West Maui; M, Maui; EM, East Maui; H, Hawai'i; the *question mark* indicates there is more than one equally parsimonious way to distribute the islands at that point on the area cladogram.

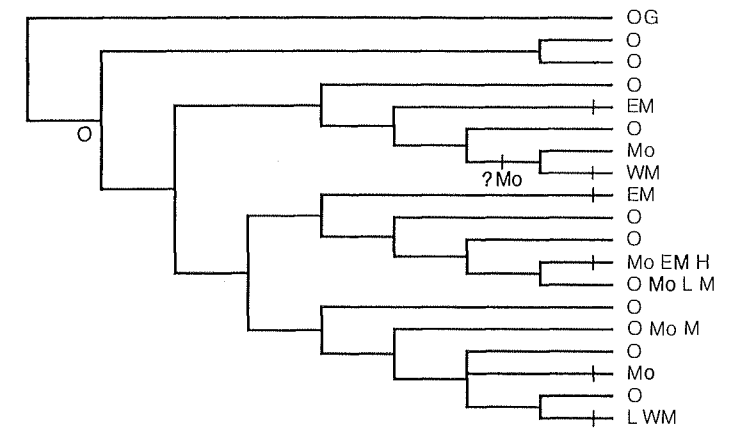

FIGURE 17.27. Area cladogram from Figure 17.26 after the removal of all the taxa found exclusively on Kaua'i. OG, outgroup; O, O'ahu; Mo, Moloka'i; L, Lana'i; WM, West Maui; M, Maui; EM, East Maui; H, Hawai'i; the *question mark* indicates there is more than one equally parsimonious way to distribute the islands at that point on the area cladogram.

Cyanea (Givnish et al., Chapter 14)

The area cladogram for *Cyanea* is one of the most-parsimonious cladograms (Figure 17.28). All the competing cladograms resolve the two main clades found in this diagram. The differences among these trees involve whether various groups of taxa are grades or clades. The area cladogram presented is one of the least resolved of any of the most-parsimonious trees. A biogeographic analysis of any of the other trees is consistent with results from the tree analyzed here.

In Figure 17.28, the clade with the fewest terminal taxa (clade A) has a Kaua'i grade at the base with two radiations, one on Kaua'i and the other on the islands of the Maui Nui complex. The second, larger clade (clade B) has a base on Kaua'i and an unresolved polytomy with three branches, one of which branches again, for a total of four clades. All four clades appear to represent radiations, one each on Kaua'i and O'ahu and two within the Maui Nui complex. The inter-island colonization pattern is difficult to determine because of the polytomy and because there are at least two, if not three, separate radiations within the Maui Nui complex involving both main clades. However, the two well-defined clades combined with the ambiguity of the relationships among the clades fits the

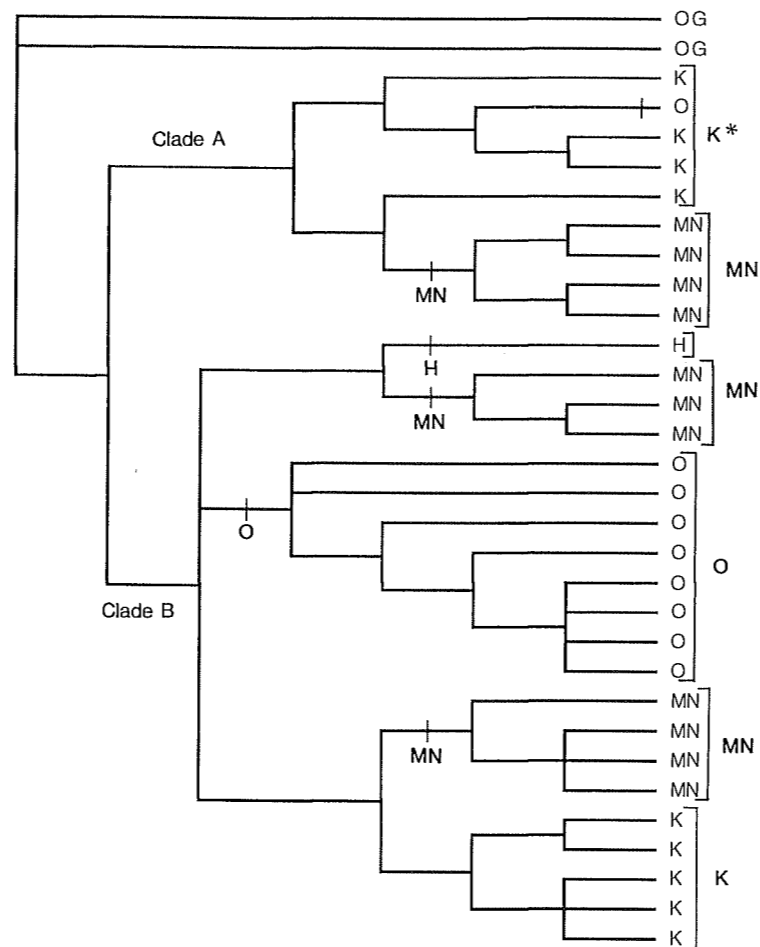

FIGURE 17.28. One of the equally parsimonious area cladograms for *Cyanea*, data from Givnish et al. (Chapter 14), with the two principal clades indicated as A and B. OG, outgroup; K, Kaua'i; O, O'ahu; MN, Maui Nui complex; H, Hawai'i; an *asterisk* denotes a group of taxa that form a grade, and all other groups are clades.

terminal resolution pattern and supports either an initial radiation on Kaua'i or an origin on an older island.

Sarona (Asquith, Chapter 7)

The area cladogram for *Sarona* (Figure 17.29) has a basal polytomy of five clades, each of which represents a radiation. This represents a termi-

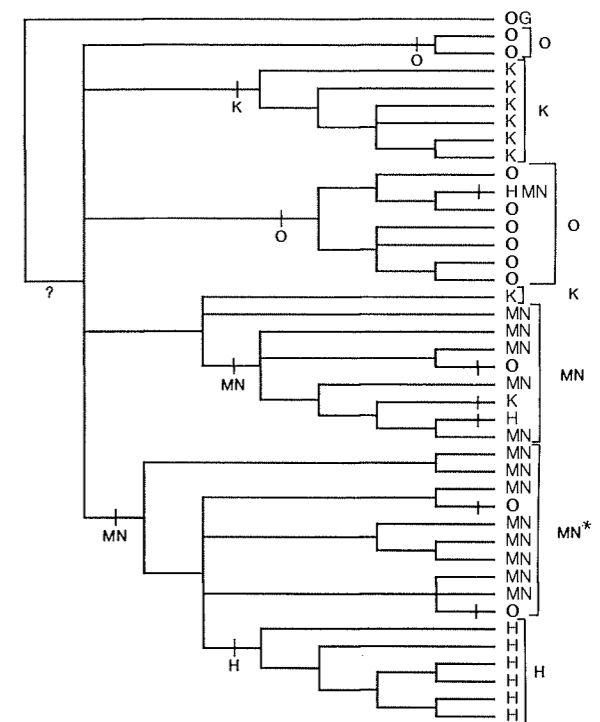

FIGURE 17.29. Area cladogram for *Sarona*, data from Asquith (Chapter 7). OG, outgroup; K, Kaua'i; O, O'ahu; MN, Maui Nui complex; H, Hawai'i; the *question mark* indicates there is more than one equally parsimonious way to distribute the islands at that point on the area cladogram; an *asterisk* denotes a group of taxa that form a grade, and all other groups are clades.

nal resolution pattern. The unresolved base may indicate early widespread dispersal of the ancestor or dispersal from an older, now-eroded island.

There are several distinctive features of the *Sarona* area cladogram. One of the groups in the basal polytomy shows a radiation on Kaua'i. Moreover, although the unresolved nature of the base makes several scenarios possible, none of the possibilities include an origin on the youngest island, Hawai'i. In fact, the only species on Hawai'i are in one of the clades of the terminal polytomy; this Hawai'i clade exhibits a radiation pattern. Radiations are also on O'ahu (with dispersal to the Maui Nui complex and Hawai'i) and within the Maui Nui complex. A back-dispersal occurs within the group to O'ahu. The central part of the

cladogram is occupied by a grade on the islands of the Maui Nui complex. Thus, it is clear that the Hawai'i clade originated from within the terminal Maui Nui clade, suggesting dispersal from Maui Nui to Hawai'i. The relationship of this clade to the other clades on the Maui Nui complex, O'ahu, and Kaua'i is ambiguous. Asquith points out that within taxa on the Maui Nui complex, there is some evidence of a vicariant pattern.

Hawaiian *Scaevola* (Patterson, Chapter 16)

At first glance, Hawaiian *Scaevola* species as a group appear to exhibit a stochastic pattern, because all but one of the species of this lineage (the seven species of the core clade) (Figure 17.30A) are found on more than one of the main islands and five species each occur on Moloka'i and Kaua'i. However, the fewest possible number of dispersal events are required if the ancestor of this clade originated on Moloka'i or Kaua'i, and Figure 17.30B presents the results of a Moloka'i origin. The distribution of the lineage can be explained by a radiation on Moloka'i with two dispersal events associated with speciation, and the remaining speciation could all have taken place on Moloka'i, followed by expansion of the

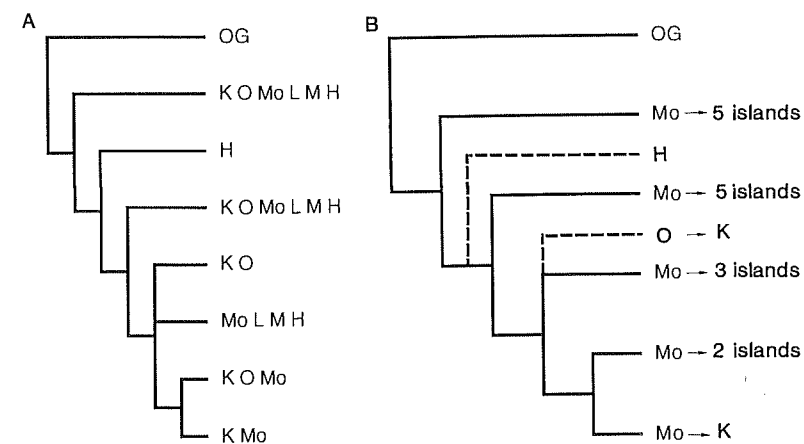

FIGURE 17.30. Area cladograms for the core group of Hawaiian species of *Scaevola* (excluding *S. glabra*), data from Patterson (Chapter 16). (A) General area cladogram; (B) alternative area cladogram showing a Moloka'i origin for the clade. It is equally parsimonious to hypothesize a Kaua'i origin for the clade. The number or island (when only one is involved) of additional inter-island colonizations is indicated to the right of an arrow. OG, outgroup; K, Kaua'i; O, O'ahu; Mo, Moloka'i; L, Lana'i; M, Maui; H, Hawai'i.

range by dispersal of the new species to different islands. As mentioned above, the same results are found using Kaua'i as the location of the ancestor of this clade, and only one additional inter-island dispersal event is required for either O'ahu or Hawai'i to be the location of the ancestor. Most likely, the ancestor of the core *Scaevola* clade colonized one of the main Hawaiian Islands, radiated on that island, and subsequently dispersed to most of the islands. It is possible that random dispersal would produce the stochastic pattern and that the species then dispersed to other islands; however, this is a less-parsimonious scenario.

Clermontia (Lammers, Chapter 15)

Most of the equally parsimonious area cladograms for *Clermontia* suggest a Hawai'i base, but a few of them were equivocal, with a Maui or Hawai'i origin. Thus, the resolution of all area cladograms clearly indicated an origin on a younger island. The cladogram (Figure 17.31) is poorly resolved, with very little information on the relationships among the taxa. This could be the result of either repeated dispersal from an older island or a widespread ancestor. Unlike other lineages investigated that had poorly resolved bases, this tree does not have either progressions or radiations in its terminal clades, so it does not fit the terminal resolution pattern. This clade is at least the result of a radiation on Hawai'i, with repeated back-dispersal to older islands.

Clermontia, however, is the sister group of the *Cyanea* clade (see Givnish et al., this volume, Chapter 14), and as such, they share a common ancestor. If *Cyanea* originated on Kaua'i or an even older island as the data seem to indicate, then either the ancestor of both genera was on the younger islands and back-dispersed to Kaua'i to give rise to *Cyanea* or the ancestor colonized Kaua'i or a pre-Kaua'i island. The ancestor of the extant species of *Clermontia* then dispersed to younger islands to give rise to the current species. If this is true, why are the current *Clermontia* species on older islands clearly derived via back-dispersal? The forest habitats where *Clermontia* species occur on younger islands appear very similar to forests on Kaua'i, suggesting that habitat availability is not the limiting factor. However, closer examination of older island forests suggests that there are ecological differences among the forests of ever-increasing ages (Mueller-Dombois, 1987). These ecological differences could make forests of older islands such as O'ahu and Kaua'i less suitable for successful colonization by or persistence of *Clermontia*. With the present area cladogram, it is difficult to speculate beyond the sup-

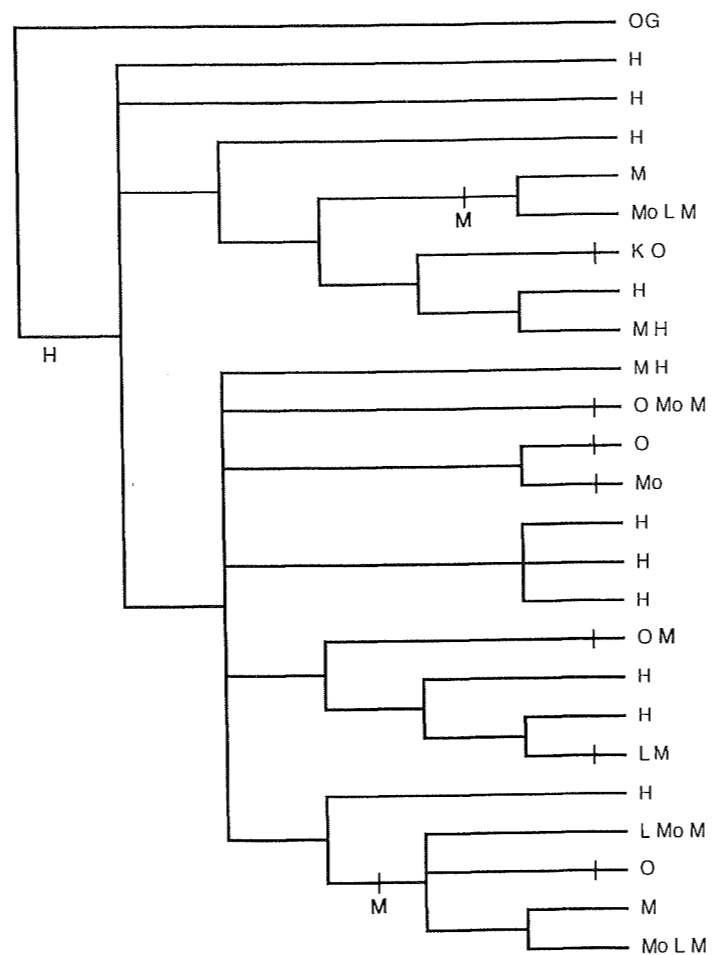

FIGURE 17.31. One of the equally parsimonious area cladograms for *Clermontia*, data from Lammers (Chapter 15). OG, outgroup; K, Kaua'i; O, O'ahu; Mo, Moloka'i; L, Lana'i; M, Maui; H, Hawai'i.

ported conclusion for the extant taxa—radiation on a younger island followed by back-dispersal.

Hawaiian *Tetramolopium* (Lowrey, Chapter 11)

There are 10 equally parsimonious cladograms for Hawaiian *Tetramolopium*. Two of the area cladograms are shown in Figure 17.32. All the area cladograms fall into one or the other of these two biogeographic patterns. Both cladograms show a younger island pattern with multiple

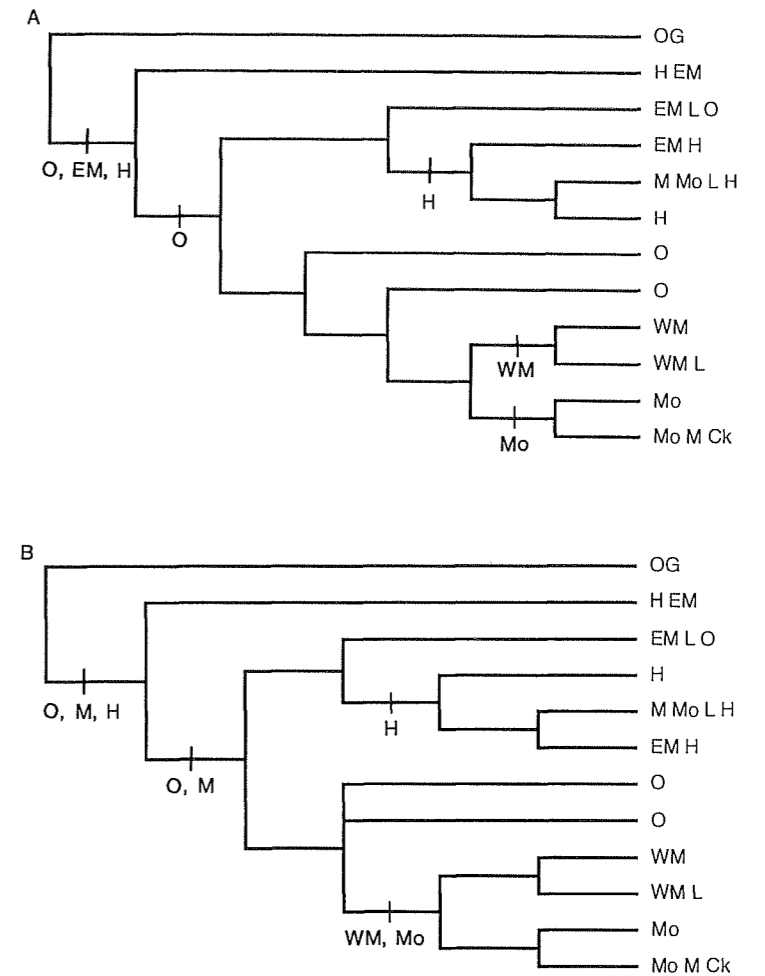

FIGURE 17.32. Two of the 10 equally parsimonious area cladograms for the Hawaiian species of *Tetramolopium*, data from Lowrey (Chapter 11). All area cladograms gave one or the other of these alternative results. (A) Area cladogram with an O'ahu ancestor for the two main subclades; (B) area cladogram with an equivocal ancestor for the two main subclades. OG, outgroup; O, O'ahu; Mo, Moloka'i; L, Lana'i; EM, East Maui; WM, West Maui; M, Maui; H, Hawai'i; Ck, Cook Islands.

dispersal events to older islands. Figure 17.32A shows an equivocal origin with inter-island dispersal associated with speciation to form a O,M,H → O → WM and Mo pattern and a separate pattern of O → H. The second hypothesis (Figure 17.32B) is equivocal at most nodes including the base and differs largely from the first because of the different topology with an unresolved trichotomy in the lower subclade. Neither tree shows any semblance of a younger-to-older island pattern, which may be attributed to the dispersal ability of the taxa. Thus, this may be an example of the stochastic pattern. Other species of the genus are found on New Guinea and in the Cook Islands. The fact that the Hawaiian species form a monophyletic group (with one Hawaiian species also on the Cook Islands) and the close similarity of the *Tetramolopium* species suggest that the Hawaiian clade may represent a recent colonization pattern.

Both *Clermontia* and *Tetramolopium* exhibit similar biogeographic patterns in that both occur primarily on younger islands. Another shared feature is that in each clade, many species have multi-island distributions. There also is poor resolution of the island of origin of each clade. Finally, the patterns within these lineages are neither radiations nor progressions. Yet *Clermontia* possibly had an origin on an older island with only the current extant species on younger islands, whereas *Tetramolopium* appears to represent a recent colonization to the archipelago.

Platydesma (Funk and Wagner, Chapter 10)

Platydesma has two well-defined clades, but each has only two species; thus, biogeographic pathways are obscure (Figure 17.33). The area clado-

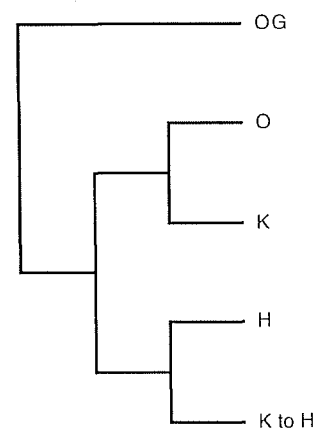

FIGURE 17.33. Area cladogram for *Platydesma*, data from Funk and Wagner (Chapter 10). OG, outgroup; K, Kaua'i; O, O'ahu; H, Hawai'i.

gram is compatible with several explanations; the one that seems best supported by morphology, however, is a Kaua'i, O'ahu, or perhaps a pre-Kaua'i radiation, followed by two independent dispersal events to younger islands of the archipelago.

SUMMARY OF PATTERNS

The following listing and Table 17.2 summarize the hypothetical patterns that were supported by the area cladograms.

Progression Rule Pattern

The basic progression rule pattern was found in the six lineages of *Drosophila* (also including a single radiation on Maui and two on Hawai'i), *Hesperomannia*, *Kokia* (with one back-dispersal), *Remya*, and the spiny leg clade of *Tetragnatha*.

Radiation Pattern

Five lineages exhibited a simple pattern of radiation: *Geranium*, honeycreepers (doubtfully), silverswords (*Argyroxiphium* and *Wilkesia*), *Platydesma*, and *Scaevola* (possibly). A number of other taxa exhibited a radiation as a secondary pattern (Table 17.2).

Unresolved Pattern

Only the genera *Clermontia* and *Sarona* presented cases that were basally unresolved. If *Clermontia* originated on Hawai'i, this group also exhibits one of the highest levels of back-dispersal.

Stochastic Pattern

Both *Tetramolopium* and the honeycreepers exhibited a stochastic pattern, but the basis differs. *Tetramolopium* apparently represents a recent colonization, whereas inter-island distances are not a significant dispersal barrier for the honeycreepers. It is less clear whether *Scaevola* fits this pattern or a radiation pattern. The current species of *Clermontia* exhibit a recent colonization pattern.

TABLE 17.2. Summary of Patterns Exhibited by Hawaiian Lineages Examined in This Book

Base or single patterns		
Progression rule	Radiation (cont.)	Back-dispersal
<i>Drosophila</i>	<i>Platydesma</i>	<i>Clermontia</i>
<i>Hesperomannia</i>	<i>Sarona</i> *	<i>Geranium</i>
<i>Hibiscadelphus</i>	<i>Scaevola</i> (possibly)	<i>Kokia</i>
<i>Kokia</i>	<i>Schiedea membranacea</i>	<i>Laupala</i>
<i>Remya</i>	clade* (doubtfully)	<i>Prognathogryllus</i>
<i>Tetragnatha</i> (2 <i>spiny leg</i>	Silverswords	<i>Sarona</i>
clades)	(<i>Argyroxiphium</i> and	<i>Scaevola</i>
Radiation	<i>Wilkesia</i> *)	(possibly)
<i>Clermontia</i> *	<i>Tetragnatha</i> * (<i>elongate</i>	<i>Schiedea</i>
<i>Cyanea</i> *	clade)	<i>Tetragnatha</i>
<i>Geranium</i>	Stochastic	<i>Tetramolopium</i>
<i>Hibiscadelphus</i> *	• High vagility	(possibly)
Honeycreepers	Honeycreepers (probably)	Unresolved
(doubtfully)	<i>Scaevola</i> (probably)	<i>Clermontia</i>
<i>Laupala</i> *	• Recent colonization	<i>Sarona</i>
<i>Prognathogryllus</i> * (Maui	<i>Clermontia</i>	
and Hawai'i)	<i>Tetramolopium</i>	
Combined or special patterns		
Progressive clades and	Terminal resolution (cont.)	Possible vicariant
grades	<i>Sarona</i>	<i>Sarona</i> (Maui Nui
<i>Drosophila</i>	<i>Schiedea-Alsinidendron</i>	complex)
<i>Laupala</i>	Extinction	<i>Schiedea</i> (Maui Nui
<i>Prognathogryllus</i>	<i>Clermontia</i>	complex)
Silverswords (<i>Dubautia</i>)	<i>Geranium</i> (possibly)	<i>Tetragnatha</i> (<i>elongate</i>
<i>Tetragnatha</i>	<i>Schiedea membranacea</i>	clade, Maui Nui
Terminal resolution	clade (possibly)	complex)
<i>Cyanea</i>	Silverswords	
<i>Drosophila</i> (overall)	(<i>Argyroxiphium</i>)	

Notes: Asterisks indicate secondary patterns within terminal clades in an overall lineage. Parenthetical notations indicate the extent or portion of the lineage involved, or in some cases, the level of uncertainty about the pattern detected (e.g., if it is thought to be an artifact of weak data or other compounding factors).

Back-Dispersal Pattern

Many of the lineages have one or a few species that appear to be the result of back-dispersal, including *Clermontia*, *Geranium*, *Kokia*, *Laupala*, *Prognathogryllus*, *Sarona*, *Schiedea*, *Tetragnatha*, and possibly *Tetramolopium* and *Scaevola*. Although there are a few documented back-dispersal

events in these cladograms, they are usually to the next older island. The greatest distance back-dispersal event among the main islands would be from Hawai'i to Kaua'i. Examining all the lineages, we find that there is only one event that is unequivocally a back-dispersal from Hawai'i to Kaua'i: *Prognathogryllus*, in which a single Kaua'i species is embedded in a clade of Hawai'i species. A second, less clear case is *Kokia*. The other potential examples have sister species separated by less overall dispersal distance.

Progressive Clades and Grades Patterns

Progressive clades and grades are treated together because both result from radiations and differ only in which taxon of the group is involved in dispersal to another island. Several of the taxa fit this pattern, including the *elongate* clade of *Tetragnatha* (which also exhibits radiations on the Maui Nui complex and Hawai'i), both *spiny leg* clades of *Tetragnatha* (one of which includes a radiation on East Maui, the other a radiation on Maui), *Prognathogryllus* (including radiations on Kaua'i, O'ahu, Maui, and Hawai'i), *Laupala* (including radiations on Kaua'i, O'ahu, Maui, and Hawai'i), *Hibiscadelphus* (including a radiation on Hawai'i), and *Dubautia* (including radiations on Kaua'i, the Maui Nui complex, and Hawai'i).

Terminal Resolution

Taxa showing a terminal resolution pattern have several well-defined clades, but there is no clear inter-island progression rule evident as an overall pattern. Instead, the overall pattern is either a radiation or unresolved. Included in this category are the *Schiedea-Alsinidendron* clade, *Sarona*, *Cyanea*, and probably the Drosophilidae. In *Schiedea* and *Alsinidendron*, the basal pattern is one of a radiation on Kaua'i with a basal clade and grade on Kaua'i and three clades that each follow the progression rule. *Sarona* has a basal pattern that is unresolved, and clades are radiations, including two on Kaua'i, one on O'ahu, and three on the Maui Nui complex. An intermediate example is *Cyanea*, which has a well-resolved basal dichotomy that gives the area cladogram a Kaua'i base but otherwise has a mostly unresolved pattern within the largest clade (clade B, Figure 17.28). Although unresolved, clade B has four clades that are radiations, two on Maui Nui, one on O'ahu, and one on Kaua'i. Clade A has a grade on Kaua'i and a clade on the Maui Nui complex. Perhaps the pattern in *Cyanea* best illustrates why the two basal

patterns are treated together. The difference depends on how closely related the original ancestors of the clades were and whether they retained any of their unique characters.

One group that will eventually fall into the terminal resolution category is the overall pattern for DeSalle's six clades of *Drosophila*. Each clade has a progression rule pattern, but at this time, the overall pattern has not been analyzed well enough to determine whether the basal pattern will be a radiation or unresolved.

Recent Colonization

Tetramolopium appears to be the only lineage examined in this volume that clearly exhibits a pattern of recent colonization to the archipelago, although if *Geranium* has not experienced older-island extinctions, it too would exhibit a recent colonization pattern.

Extinction

The absence of sources of information such as a fossil record hamper a valid assessment of extinction. However, the analyses suggest an extinction pattern for several groups including *Clermontia*, *Geranium*, *Argyroxiphium*, and apparently, the *Schiedea membranacea* lineage.

HIGHER-LEVEL SIMILARITY IN BIOGEOGRAPHIC PATTERNS

Study of all the patterns suggests that several overall groupings of the area cladograms can be made. First, how well supported are the two most common patterns, progression and radiation? There are four examples of radiation as a basic pattern. The honeycreepers may have a radiation on Kaua'i, an old island. *Geranium* and *Argyroxiphium* have radiations on East Maui, a young volcano (but both clades may have had their origin on an older island). *Scaevola* has a single-island radiation pattern, but the species have dispersed to other islands, making determination of the island where the original radiation took place impossible.

Radiation (intra-island speciation) in general has played an important role in the diversification of the Hawaiian biota. For instance, several groups had major radiations on multiple islands. The largest of these were found in *Sarona*, *Cyanea*, the two cricket genera *Prognathogryllus* and *Laupala*, the elongate clade of *Tetragnatha*, and the *Dubautia-Wilkesia* clade of the silversword alliance. *Sarona* and *Cyanea* had a

largely ambiguous overall inter-island pattern, and the other taxa followed the progression rule. If one totals the number of radiations across all groups studied that have 3 or more species on a single island, including the single-island radiation clades, then Kaua'i has 6, O'ahu has 4 or 5, Maui has 7 (and the rest of the Maui Nui complex has an additional 6, for a total of 13 for the entire Maui Nui complex), and Hawai'i has 6. In most groups, the Hawai'i radiations were one of the terminal branches of the cladogram. O'ahu shows the fewest number of radiations, either four or five (one in each of the cricket genera, one in *Sarona*, one in *Cyanea*, and perhaps one in *Schiedea*). There is no clear reason why this should be so, except that O'ahu has experienced a much greater habitat alteration beginning with the arrival of the Polynesians and continuing to the present, which may have caused differential extinctions.

The progression rule was also common. Eighteen of the 25 lineages studied have an area cladogram that follows the progression rule either as an overall pattern or as a subpattern. Four of the 25 lineages have a single-island radiation pattern, so are excluded from this count. Among the remaining three lineages, *Tetramolopium* is probably a recent introduction to the archipelago, *Clermontia* may represent an extinction pattern (but one difficult to distinguish from that of a recent colonization pattern), and *Platydesma* breaks into two two-taxa statements (so is agreeable to many patterns, including the progression rule).

What is the balance between inter-island dispersal events associated with speciation and intra-island radiation? In the data sets included in this volume, slightly more than 100 events of inter-island dispersal are associated with speciation and there are slightly more than 200 intra-island events, for an approximate ratio of 1:2.

How important are habitat shifts and inter-island dispersal in promoting speciation? In the case of inter-island dispersal, isolation may be great enough to allow speciation without habitat shifts. If so, a greater number of habitat shifts should be observed in intra-island radiations than in inter-island diversification. Hawaiian Drosophilidae represent one end of the spectrum in that most speciation has occurred with colonization of a new island. This has suggested the idea of genetic destabilization accompanying a founder dispersal to new islands, which may be sufficient to promote speciation (Carson, 1987a). Several authors have contrasted intra- and inter-island speciation with habitat shifts. At least several of the plant groups, including *Cyanea*, *Geranium*, *Schiedea*, and the silversword alliance, have documented habitat shifts associated with speciation, and shifts appear to be more frequent with intra-island

radiations. Similar ecological shifts have been documented in many of the other taxonomic groups studied here, and at least some of them show a greater tendency for shifts to occur in intra-island radiations. *Sarona*, the *elongate* clade of *Tetragnatha*, and the cricket genera provide examples in that host plant shifts or ecological or behavioral shifts appear to occur more commonly in intra-island radiations. How common this is in other groups that have radiations on single islands is not certain but surely warrants investigation.

Several findings should be viewed with caution by evolutionary biologists who work on interspecific relationships without a phylogeny. Even in such closely related groups as the members of a lineage on the Hawaiian Islands, one cannot be sure that species from the same lineage on the same island are closely related to one another. They could be sister taxa, but they could also be members of different radiations (e.g., *Cyanea*), individuals from different progressions (e.g., *Schiedea*), the result of back-dispersal (e.g., *Sarona*), or even independent dispersals from another island (e.g., honeycreepers).

CONCLUSIONS

The most frequent pattern found among the lineages presented in this volume is one of dispersal from older to younger islands in the form of the progression rule and progressive clades and grades. There are also several potential older island patterns and several instances of back-dispersal and single-island radiation patterns. Many lineages exhibited radiations on individual islands that can be investigated for adaptive radiation and vicariance.

Clearly, the investigations in this volume have demonstrated very strong patterns in biological diversification on this hot spot archipelago, many of which are consistent with one another. The most common patterns are progression, radiation, and combinations of the two. Judging from the species-rich groups examined in this volume, speciation on the Hawaiian Islands occurs approximately one-third inter-island and two-thirds intra-island.

Finally, evidence indicates that the geologic history of the islands has a very powerful influence on the evolutionary history of successful colonists. More important, these studies have shown that one can tell when the influence of geology is important to radiation and when it is not. The results of these analyses show that phylogenetic analysis can be very informative concerning the relationship between the phylogeny of

the Hawaiian organisms and the geologic history of the islands. Furthermore, they show the use of phylogenetic systematics as a method for examining the evolutionary history of organisms.

ACKNOWLEDGMENTS

We thank the members of the Duke University systematics discussion group and the American Museum of Natural History discussion group for providing a format for presenting some of the ideas developed in this chapter. We appreciate the cosponsorship by the American Society of Plant Taxonomists and the Association of Tropical Biology of the symposium at the Honolulu American Institute of Biological Sciences meetings where the basic group involved in developing this volume first examined many of the ideas presented here. S. G. Weller, B. Baldwin, and P. Cannell provided thoughtful comments on drafts of the manuscript, which improved it greatly. We thank G. McKee for assisting in the production of the figures.