

FEEDBACK MECHANISMS

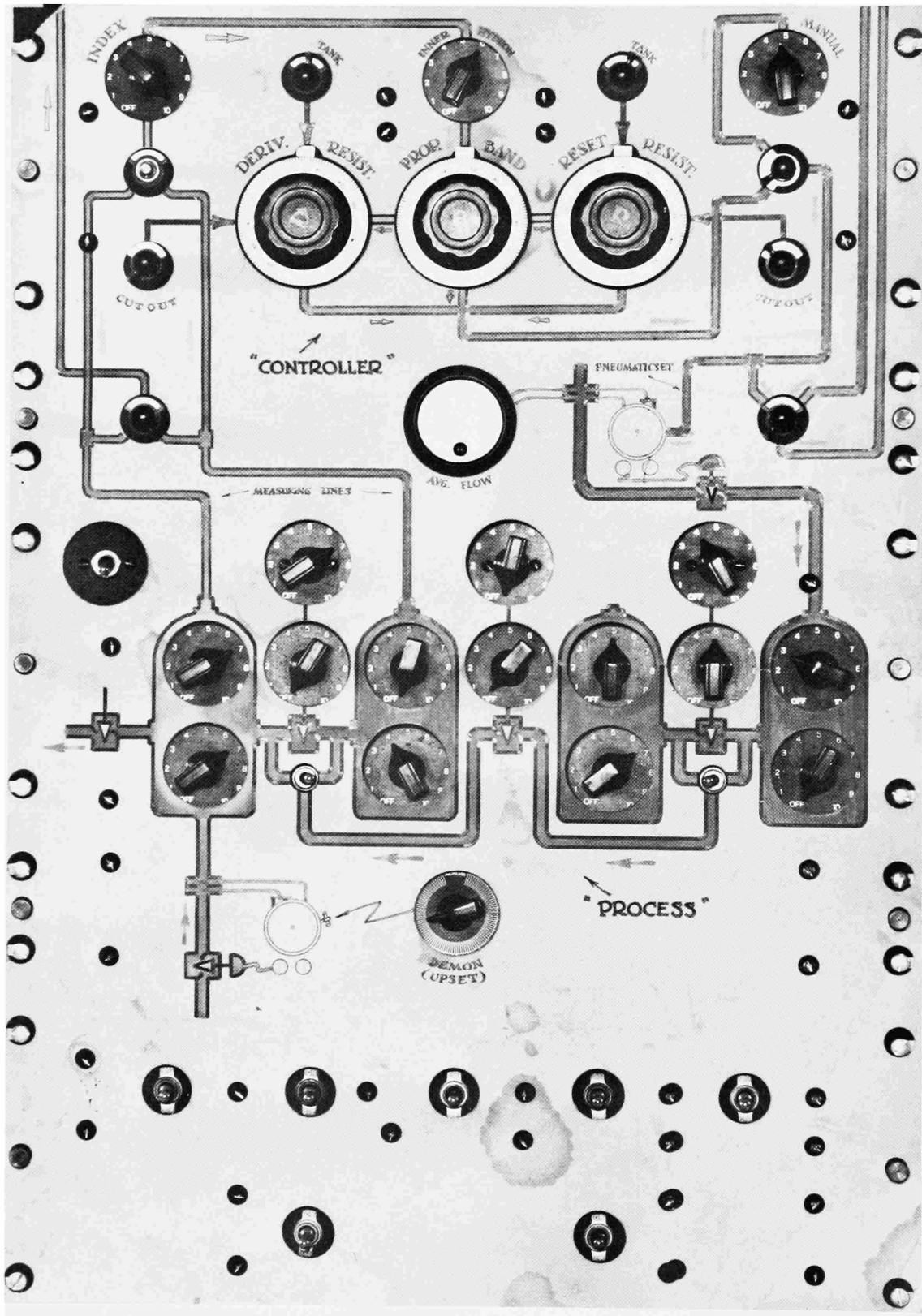

E
171
5664
W0112
M
C02

SMITHSONIAN STUDIES IN HISTORY AND TECHNOLOGY

NUMBER 12

Feedback Mechanisms

IN THE HISTORICAL COLLECTIONS OF THE
NATIONAL MUSEUM OF HISTORY AND TECHNOLOGY

By Otto Mayr

ISSUED

JUL 20 1971



SMITHSONIAN INSTITUTION PRESS

CITY OF WASHINGTON

1971

SERIAL PUBLICATIONS OF THE SMITHSONIAN INSTITUTION

The emphasis upon publications as a means of diffusing knowledge was expressed by the first Secretary of the Smithsonian Institution. In his formal plan for the Institution, Joseph Henry articulated a program that included the following statement: "It is proposed to publish a series of reports, giving an account of the new discoveries in science, and of the changes made from year to year in all branches of knowledge." This keynote of basic research has been adhered to over the years in the issuance of thousands of titles in serial publications under the Smithsonian imprint, commencing with *Smithsonian Contributions to Knowledge* in 1848 and continuing with the following active series:

Smithsonian Annals of Flight
Smithsonian Contributions to Anthropology
Smithsonian Contributions to Astrophysics
Smithsonian Contributions to Botany
Smithsonian Contributions to the Earth Sciences
Smithsonian Contributions to Paleobiology
Smithsonian Contributions to Zoology
Smithsonian Studies in History and Technology

In these series, the Institution publishes original articles and monographs dealing with the research and collections of its several museums and offices and of professional colleagues at other institutions of learning. These papers report newly acquired facts, synoptic interpretations of data, or original theory in specialized fields. These publications are distributed by subscription to libraries, laboratories, and other interested institutions and specialists throughout the world. Individual copies may be obtained from the Smithsonian Institution Press as long as stocks are available.

S. DILLION RIPLEY
Secretary
Smithsonian Institution

TO MY FATHER

Acknowledgments

This book could not have been prepared without the support of a great many members of the staff of the National Museum of History and Technology. To begin with, I received indispensable help from all the curators in whose collections I found feedback mechanisms—as well as from those in whose collections I searched in vain. I hope to be forgiven for not naming all these curators individually: the list would be too long.

Specifically, I am indebted to Virginia Beets, Silvio A. Bedini, and Robert G. Tillotson, of the Office of the Director, for help in administrative problems; to Jack Goodwin and Charles G. Berger, of the Library, for miracles in procuring needed books; and to Henry A. Alexander and Richard B. Farrar, of the Photographic Services Division, for producing the many excellent photos so quickly in spite of a heavy workload.

A few have contributed even more directly. Robert P. Multhaus, while Director of the Museum, originally suggested the project and arranged the means for its accomplishment. Robert M. Vogel, Curator of Heavy Machinery and Civil Engineering, carefully read the manuscript and suggested a number of corrections. Part of the photographs were taken by Charles L. Granquist, of the Division of Mechanical and Civil Engineering; his photographs are identified by the initials CLG. The manuscript was typed by Mrs. Catherine St. C. Scott and Mrs. Eva Y. Elliott. Also a tribute is due to my wife Louise, who has endured the hardships involved in projects such as this, as always, with humor and grace.

Preface

Among the seemingly endless variety of machinery that might be listed under the heading *automatic control*, feedback mechanisms stand out as a distinct group because, although differing widely in outward appearance, they all function according to a single principle. The significance of the principle of feedback is all the greater as it is not limited to technology. Since 1948, when Norbert Wiener adopted it as one of the unifying concepts of the new science of *cybernetics*, it has come to be regarded as an invaluable tool in such diverse disciplines as biology, economics, and sociology.

The interdisciplinary validity, for which the concept is admired, has been anticipated in technology at a much earlier period, when feedback was employed to solve problems of control, for example, in the mechanical, hydraulic, thermal, and electrical media. It might be of interest therefore to outline the history of feedback control by means of cataloging—systematically and in chronological order—the historical feedback devices contained in the collections of one of the world's great technological museums, the National Museum of History and Technology of the Smithsonian Institution.

This catalog is limited to feedback mechanisms; other forms of automatic control, for example open-loop and programmed control, are disregarded without further explanation. The material to be described has definite boundaries also in space and time. In space, it is limited to the collections of the Smithsonian Institution's National Museum of History and Technology, collections which are partly exhibited and partly stored in various storage spaces; in time, it is limited to items that can be described, at least by lenient standards, as historical. How old must an item be to qualify? Objects that are being mass-produced and commercially marketed at the present are clearly inadmissible. On the other hand, certain developments—such as in the field of computers—may have to be considered historical even if they have occurred relatively recently. A cutoff date convenient for our purposes then seems to be the end of World War II, a date we will disregard, however, when appropriate.

In an effort to make visible the more important lines of development of historical feedback devices, the material is presented in the form of a continuous narrative. This has led to an arrangement which is pragmatic rather than strictly systematic. Sometimes feedback devices are classified according to the controlled variable (e.g., speed, pressure, temperature); sometimes it has been more expedient to list them under the branch of technology where they were employed (e.g., automotive or textile). The necessary cross-references will be provided by the index.

To describe individual objects, we have to consider two kinds of information: First, information concerning its external history has been presented, at

least in concise form, as far as available, but the scope of this catalog did not permit the additional research required to close numerous gaps. Second, complicated technical objects such as we deal with here require technical description. Readers who may feel that too much space is devoted to purely technical matters should take into account that the historical significance of the objects cataloged here lies precisely in the technological ideas represented by them.

The sources used and references to additional material have been indicated as usual in footnotes. Further information may be found at two general sources. One is the archives of the individual divisions of the Museum. For access to these, researchers should consult the respective curators directly. The other concerns the patent models which form a considerable part of this material. The patented inventions are described in detail in the patent specifications, and further material may be found in the case files of the United States Patent Office and the National Archives.

The imaginative reader may miss in this catalog some items that he would have expected to find. This may be due to any one of three reasons: his definition of feedback may differ from the author's; the item may have been accidentally overlooked; or the item may actually not be represented in the collection. With regard to definition, the following practice has been followed. At the start, feedback was defined once and for all; thereafter only devices thus defined were accepted, others were disregarded without discussion. In a few cases, where whole groups of relevant objects were excluded for special reasons, as in the cases of safety valves, float-feed carburetors, or electronic devices, this was explained at the appropriate places. Second, feedback devices are rendered elusive by the interdisciplinary nature of the concept. Feedback is employed in many disguises, and it is represented in practically all divisions of the Museum. In spite of a serious effort to make this catalog exhaustive, it is only too possible that one or another item may have escaped the cataloging. Finally, the collection itself must not be expected to be complete. Feedback devices usually are inconspicuously attached to some larger machine or process which they have the function to regulate. Having rarely been collected for their own sake, they are represented unevenly. Our collection, for example, contains more than a hundred speed governors but only a few historical temperature controllers. All items listed have actually been identified in the collections.

Each individual object is identified by two numbers, the catalog number (NMHT) and the accession number. The *catalog numbers* are assigned individually to specimens by each particular Museum division according to systems which vary between different divisions. The *accession numbers* indicate the accession files in the Registrar's office and are uniform for all of the Museum. The accession files contain all correspondence and other documents relating to the transaction by which the specimen reached the Museum, often containing valuable detailed information. A single accession number may refer to more than one object. As a help in finding the objects cataloged herein, we have included a *Location Guide* at the back of the book.

Contents

	<i>Page</i>
ACKNOWLEDGMENTS	vi
PREFACE	vii
1. INTRODUCTION	1
Definition of Feedback Control	1
The Origins of Feedback Control	2
2. STEAM ENGINE GOVERNORS	4
The Classical Centrifugal Governor of James Watt	4
Automatic Cutoff Control	7
Charles T. Porter's Loaded Governor	13
Mid-Nineteenth Century Patent Models	16
Valve-Mounted Governors	27
Shaft Governors	33
3. SPEED REGULATION OF OTHER PRIME MOVERS	39
Governors of Waterwheels and Turbines	39
Mechanical Servo Governors	39
Hydraulic Servo Governors	43
Speed Regulation of Steam Turbines	45
Speed Regulation of Internal Combustion Engines	49
4. FRICTION GOVERNORS	64
Chronographs	64
Phonographs	66
Telegraphs	69
5. AUTOMATIC CONTROL OF STEAM BOILERS	70
6. PRESSURE REGULATORS	73
7. TEMPERATURE CONTROL	77
8. FEEDBACK CONTROL ON TEXTILE MACHINERY	79
9. FEEDBACK CONTROL ON LAND VEHICLES	83
Railway Technology	83
Steam Automobiles	83
Speed Governors on Trucks and Tractors	86
Automobile Thermostats	88
Float Feed Carburetors	89
Pressure Control by Relief Valves	90
Voltage and Current Regulation	90
Power Steering	92

	<i>Page</i>
10. FEEDBACK CONTROL ON WATERCRAFT	93
Servo Steering Devices	93
Feedback Control in Torpedoes	96
The Whitehead and the Bliss-Leavitt Torpedoes	96
The Howell Torpedo	99
Other Torpedoes in the Museum's Collection	100
Gyroscopic Compasses	101
The Sperry Gyropilot	102
11. FEEDBACK IN ELECTRICAL TECHNOLOGY	105
The Regulation of Electric Arc Lamps	105
Early Arc Lamps	105
Systems of Arc Lighting	107
Miscellaneous Arc Lamp Regulators	117
Feedback Control on Electric Machines	119
Constant Current Regulation in Arc Lighting Systems	119
Speed Control of Motors	123
12. ELECTRONIC COMPUTERS	125
Analog Computer for Process Control Analysis	125
Digital Process Control Computer	126
LOCATION GUIDE	127
INDEX	131

CHAPTER 1

Introduction

Definition of Feedback Control

The objects cataloged here may be referred to as governors, regulators, servomotors, or by a variety of other terms, and they may differ greatly in outward appearance and practical application. The only thing they have in common is that their operation is based on the principle of feedback. Feedback has been described by Norbert Wiener as "the property of being able to adjust future conduct by past performance."¹ The American Institute of Electrical Engineers, more formally, has given this definition: "A *Feedback Control System* is a control system which tends to maintain a prescribed relationship of one system variable to another by comparing functions of these variables and using the difference as a means of control."² We shall now try to rephrase these statements in order to obtain workable criteria for identifying feedback devices.

The first characteristic of feedback control is its purpose. Feedback devices have the function of automatically carrying out a command, that is, to control a machine or process in such manner that a *controlled variable* is maintained at equal level with a *command variable* coming from a higher authority, usually a human operator. For example, a home thermostat has the task of making the room temperature equal to a desired value

represented by a dial setting. An automobile power steering unit must point the front wheels into the direction indicated by the steering wheel. A steam engine governor has to maintain the engine speed at a value set by the operator. Feedback devices will carry out such commands in spite of external disturbances, such as, in the case of the thermostat, changing outside temperature; in the case of power steering, varying vehicle speed and road surface; or, for the steam engine, changes in steam conditions and load. The command, or desired value, is commonly called *input* (on the thermostat it is the dial setting; in power steering, the angular position of the steering wheel). The actual value of the controlled variable is the *output* (actual room temperature, or front wheel position).

Second, feedback devices act in a cause-and-effect chain that forms a *closed loop*. If, for example, in the home temperature control system, due to an outside temperature decrease, the actual room temperature drops below the desired value, the thermostat will turn on the furnace, adding heat to the room until the difference between actual and desired temperature has disappeared. The effect of the weather change then travels around the whole loop: through the response of the temperature-sensing element of the thermostat, the room temperature drop actuates the furnace. This, by causing a heat addition and hence a temperature rise in the room, reverses the response of the thermostat. After traveling once around the loop, the original effect returns with the opposite sign. Starting as a temperature drop, it returns as a temperature increase. This

1. Norbert Wiener, *The Human Use of Human Beings: Cybernetics and Society*, 2nd edition (Garden City, New York, 1954), p. 33.

2. A.I.E.E. Committee Report, "Proposed Symbols and Terms for Feedback Control Systems," *Electrical Engineering* 70 (1951):905-909.

change of sign is the basis of the stability of feedback control (often called, therefore, more precisely negative feedback). Closed-loop systems lacking this change of sign, that is, systems with positive feedback, are unstable. They are equivalent to what is commonly known as the *vicious circle*. A block diagram of a feedback control system in general is shown in Figure 1.

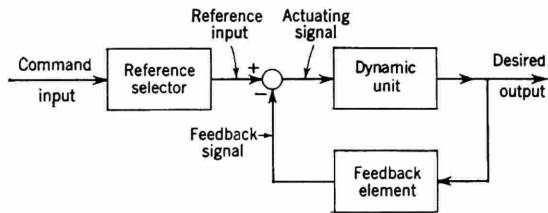

FIGURE 1.—Block diagram of a feedback control system. Reprinted from D'Azzo and Houpis, *Feedback Control System Analysis and Synthesis* (New York, 1960), p. 2. Used with permission of McGraw-Hill Book Company.

In addition to the two criteria obtained so far, we need, however, a third criterion. In nature as well as in technology, a variety of systems can be found with the property of self-regulation: such systems display a certain measure of stability under the influence of external disturbances. Mathematically, such systems can be described in terms of closed loops with negative feedback. Genuine feedback control systems are distinguished from these by that they incorporate a physically distinct element with only the function of sensing the output, that is, generating a feedback signal. This signal is then sent to a comparator element (sometimes difficult to identify), in order to be compared with the command signal.

The Origins of Feedback Control

The oldest feedback device—the float valve—dates from antiquity.³ Vitruvius reports

3. For a detailed study of the early history of feedback control, see Otto Mayr, *The Origins of Feedback Control* (Cambridge, Massachusetts, 1970).

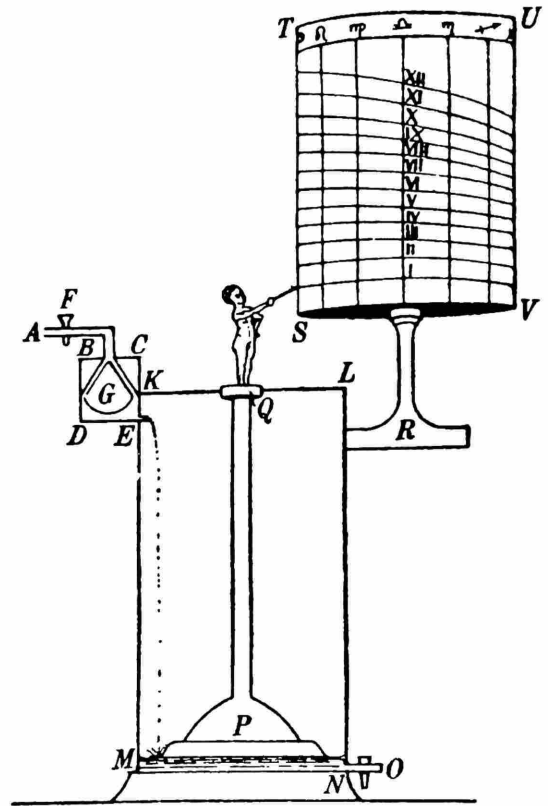

FIGURE 2.—Water clock of Ktesibios (1st half third century B.C.) as reconstructed by Hermann Diels. Reprinted from Hermann Diels, *Antike Technik*, 3rd edition (Leipzig, 1924), fig. 71.

that Ktesibios of Alexandria (first half of the third century B.C.), a mechanic at the court of King Ptolemy II Philadelphus, employed in one of his water clocks a level-regulating device (Figure 2) very similar to the float valve in today's automobile carburetor. Three centuries later, his fellow townsman, Heron of Alexandria, in his book *Pneumatica*, described several examples of another type of float valve equally familiar to us, the level regulator in WC water tanks. It should not surprise us that inventions of such refinement occurred at that particular place and time. The period between the lives of Ktesibios and Heron witnessed the culmination of Greek natural science and Roman technology, and Alexandria was then the intellectual center of the world. Knowledge of Alexandrian technology was inherited by the

Islamic world. Arabic builders of water clocks employed float valves as late as 1206. In Europe, however, this invention remained unknown until the eighteenth century when float valves were reinvented in England to regulate the levels in domestic water tanks and steam boilers.

It was also England where the first feedback device of purely European origin was invented. In about 1620 Cornelis Drebbel, a Dutch engineer in the service of King James I, constructed a chemical laboratory furnace with an automatic temperature regulator (Figure 88), an invention little noticed by his contemporaries. In the following two centuries, this invention matured gradually. It was presented to a wider public in 1839, when Andrew Ure in his "Dictionary of Arts" described several versions of a bimetallic temperature regulator which he termed *thermostat*.

Another early, if simple, feedback device is the safety valve of the classical steam boiler. The claim that it employs feedback rests on this argument: Consisting of a weight-loaded valve in the boiler wall, it compares the actual pressure (force on the inside area of the valve) with the desired pressure (weight). If the actual pressure exceeds the desired pressure, the valve will release steam until equilibrium is restored. Its inventor, Denis Papin, had originally intended it as a pressure regulator for his pressure cooker of 1681, but within only a few decades it became a standard accessory for steam boilers.

Professional groups with remarkable influence upon eighteenth-century technology were the English and Scottish millwrights. Not only did they produce a disproportionately high number of great engineers, but among their many bold and ingenious inven-

tions are several mechanisms employing feedback. The earliest of these is the fantail patented by Edmund Lee in 1745, a small auxiliary wind wheel attached to the cap of a windmill at right angles to the main wheel, with the function of always keeping the mill directed into the wind. In time the fantail became a characteristic feature of British windmills. A number of their inventions were devoted to the problem of speed regulation. A rather simple solution was found in mounting the windmill sails flexibly, so that they could recoil under a strong wind, thus presenting less area. Such schemes were proposed by E. Lee (1745), A. Meikle (1772), J. Barber (1773), B. Heame (1787), and finally, most successfully, by W. Cubitt in 1807. Genuine feedback control of speed, in contrast to these, would require some distinct speed-sensing device, such as a centrifugal fan blowing air against a flexible baffle which would be deflected through a distance proportional to fan speed (R. Hilton, 1787), or the simpler and more successful centrifugal pendulum. A first application of the centrifugal pendulum on windmills (the "lift tenter") did not involve speed control; its only purpose was to maintain a constantly fine quality of flour by counteracting a natural tendency of the millstones to separate at higher speeds. English patents of 1787 and 1789 also describe genuine feedback systems, where centrifugal pendulums control the speed of windmills by directly adjusting the sail area. Such arrangements, however, never became popular. In general, the millwrights' discovery of the possibilities of the centrifugal pendulum had its greatest success not in their own limited field but in connection with James Watt's new steam engine.

Steam Engine Governors

The Classical Centrifugal Governor of James Watt

The Newcomen steam engine as well as the earlier versions of James Watt's engine worked with a purely reciprocal power stroke, which was adequate for pumping water out of coal mines but a severe limitation in finding new applications for the engine. In order to make the steam engine marketable as a prime mover for mills, James Watt and Matthew Boulton developed a new rotary steam engine, the first unit of which was sold in 1783. As a public demonstration of the capabilities of this engine, they next took part in building in London a large progressive steam mill, the Albion Mill. This mill apparently forms the connection through which the millwrights' invention of the centrifugal pendulum was passed on to the steam engine builders. Supervisor of construction and, later, of operation of the Albion Mill was the 23-year-old John Rennie, who had served his apprenticeship under Andrew Meikle, a noted Scottish millwright, and who was to become famous himself as a builder of bridges. At the Albion Mill, Matthew Boulton saw for the first time the "lift tenter," which he described in a letter to James Watt in May 1788. It seems that this suggestion fell upon fertile ground; the earliest known references to the centrifugal governor among the Boulton & Watt papers date from November 1788, half a year after this letter. Little later, the first governor was in operation on the famous "Lap" engine (the original is at the Science Museum in London); our Museum exhibits a quarter-

scale model (Figure 3) of the "Lap" engine (NMHT 323494; Accession 249295; built in 1963 by C. A. Mills, Ruislip, England). Within a few years, the centrifugal governor became a standard component of the steam engine. James Watt, incidentally, never took out a patent for his governor; in his judgment it was not a new invention but merely an adaptation of the millwrights' lift tenter.⁴

The function of the governor is to maintain a constant speed in spite of external disturbances such as changes in load or steam pressure. Two massive metal spheres ("flyballs") on long metal rods, suspended from a common pivot point and rotating at a speed proportional to that of the engine, swing outward with rising speed. Appropriate mechanical linkages connect the pendulum with the steam inlet valve in such a way that the steam supply is throttled with rising speed, and increased with falling speed, so that, under a given load condition, the engine will reach a certain equilibrium of speed. In equilibrium, the opening of the valve—as determined by the centrifugal displacement of the flyweights—is just sufficient to admit the amount of steam required to maintain this speed. If a load increase causes the speed to drop, the action of the flyballs will increase the valve opening by an amount proportional to the speed change, with the result of bringing the speed back toward the equilibrium valve.

A particular type of feedback control represented by the simple centrifugal governor is called "proportional control." Its mode of

4. H. W. Dickinson and Rhys Jenkins, *James Watt and the Steam Engine* (Oxford, 1927), pp. 220–223.

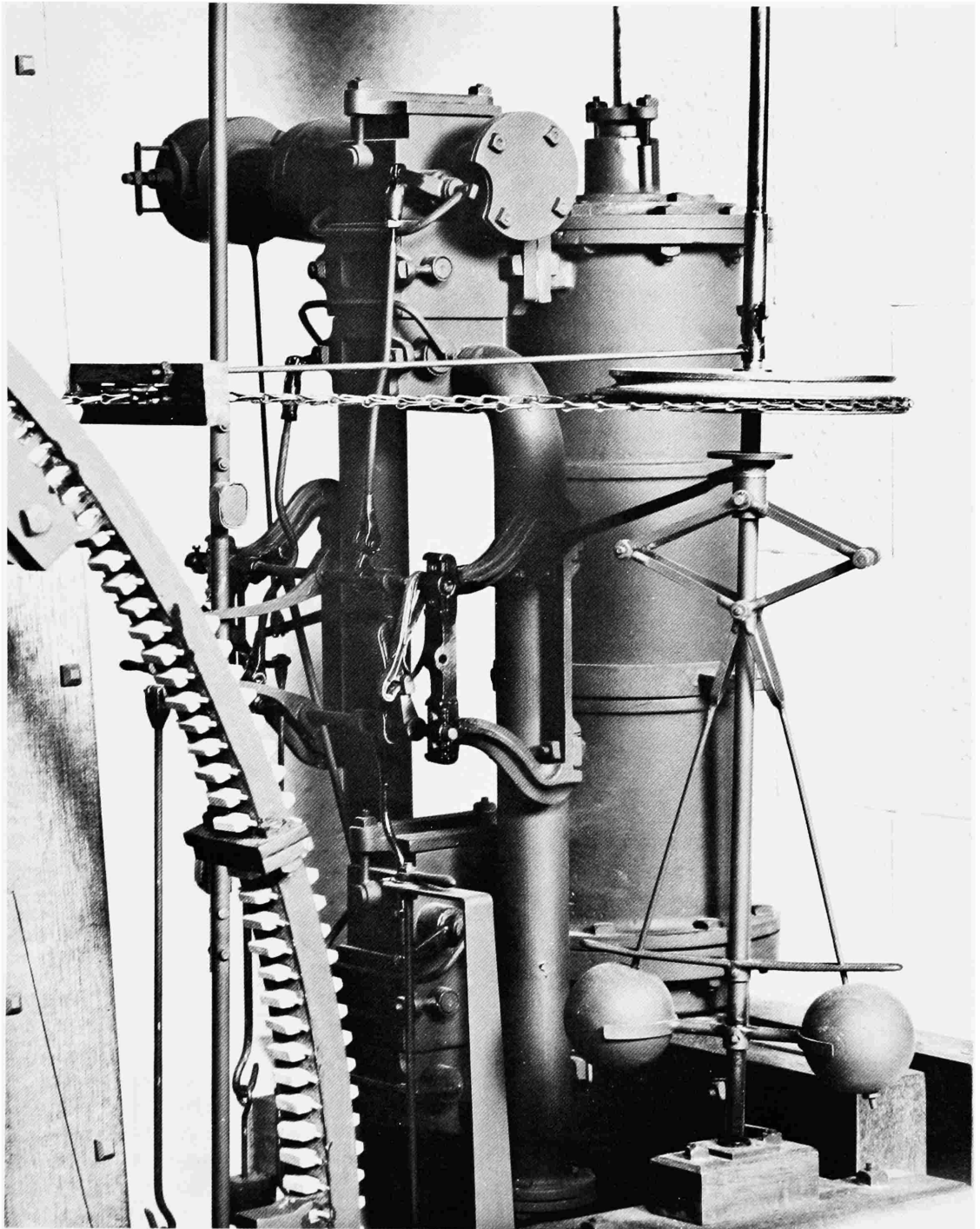

FIGURE 3.—Model of James Watt's "Lap" Engine of 1788. The detail view shows the centrifugal governor with its drive and its connections to the steam valve (top left). (NMHT 323494. Smithsonian photo P-64116.)

operation involves an operational shortcoming, illustrated by the example of the governor. Upon a load change, the corrective action—namely, the increase in steam flow—is directly caused by the drop in speed, and it could not be maintained without a lasting speed deviation. In proportional control systems, this error can never be completely eliminated, because the control action is based on it, although for sensitive systems it may be very small. The problem of the “proportional offset” has some historical significance. In the nineteenth century, a good deal of inventive effort was devoted to the search for “isochronous” or “astatic” governors that would be free from this defect, and a large amount of theoretical literature discussed the feasibility of such governors.

In Watt’s original arrangement, the centrifugal pendulum was a considerable distance removed from the throttle valve, which necessitated linkages of sometimes great length. Since the pendulum rotated at a very low speed the necessary centrifugal force had to be generated by making the flyballs very heavy, which had the unwanted side effect of making the system slow to respond to changes in speed. The restituting force—that is, the force which returned the pendulum to its rest position—was provided by the weight of the flyballs alone. This arrangement remained in use for roughly half a century.

The oldest centrifugal governor in our collections belongs to the steam engine built by Thomas Holloway in 1819, believed to be the oldest American-built stationary steam engine extant (NMHT 319405; Accession 239089). The 10-hp condensing engine served in a Philadelphia brewery until 1872. The machine is not fully preserved, but the large governor (48” high, 32” spread) is complete (Figure 4). Driven by rope and pulley, it was mounted on a small floor above the engine, as shown on a small model built in 1964 in the Museum (NMHT 323716; Accession 252392). As in James Watt’s original design, the centrifugal motion of the flyballs is transmitted to the throttle valve by a lazy-tongs linkage. The governor is driven by a step pulley with three different diameters. This re-

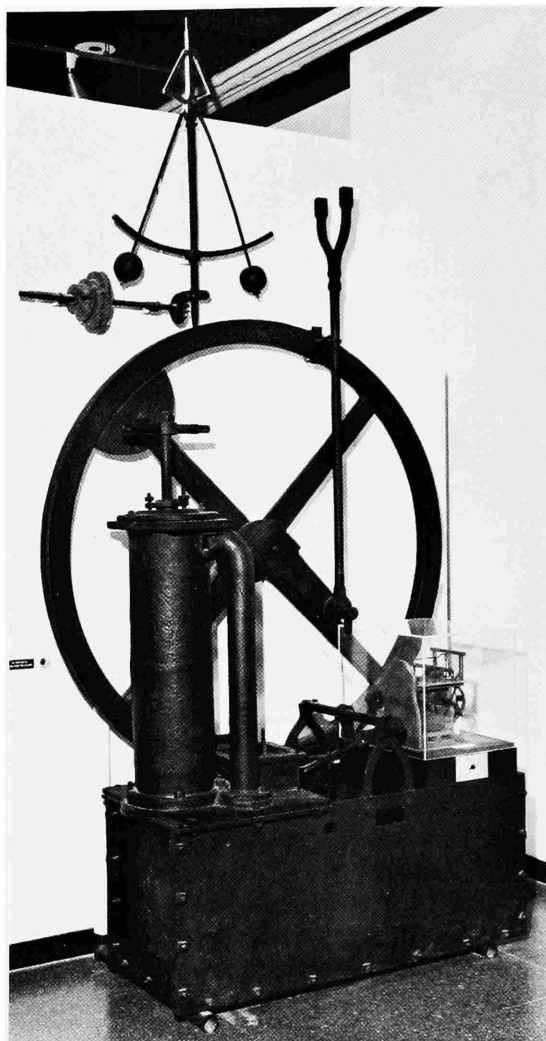

FIGURE 4.—Steam engine built in 1819 by John Holloway of Philadelphia. In the arrangement shown, the governor is not connected to the engine. Originally it was installed on the floor above the engine. (NMHT 319405. Smithsonian photo 72169.)

sembles the arrangement on a 1798 drawing from the Boulton & Watt shops and is meant to be a provision for changing the controlled speed of the engine (actually, it changes mainly the proportional sensitivity, not the reference level of speed).⁵

Almost as old, but considerably better preserved, is Mathias W. Baldwin’s large steam engine of 1829, built by the famous Philadel-

5. *Ibid.*, pl. 81.

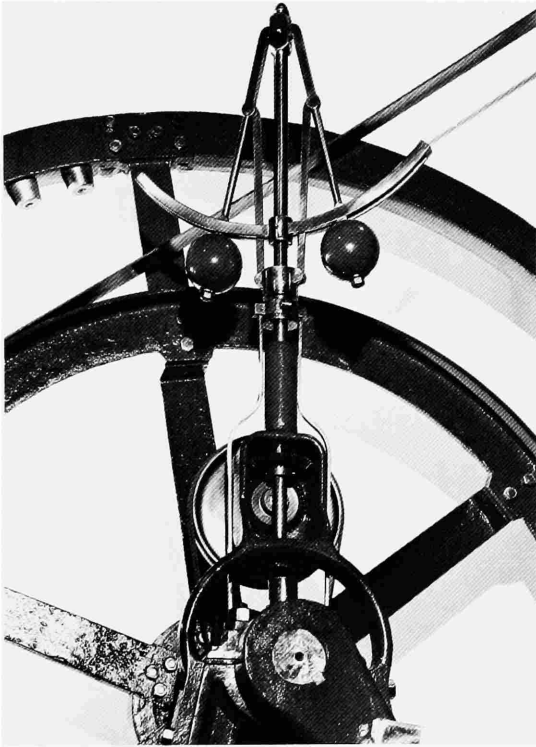

FIGURE 5.—Governor of steam engine built by Mathias W. Baldwin in Philadelphia, 1829. (NMHT 314822. Smithsonian photo 72173.)

phia locomotive manufacturer to provide power for his own machine shop (NMHT 314822; Accession 210004). By employing an unusual yoke-type connecting rod he was able to reduce the engine size substantially. The governor (Figure 5), otherwise conventional, is linked to the throttle valve by a peculiar forked bar straddling the engine shaft.⁶

A good illustration of the traditional arrangement of the centrifugal governor is given by the Harlan & Hollingsworth 40-hp beam engine, built in 1850, and used from 1851 to 1927 to operate a Charleston, S. C., railroad shop (NMHT 314791; Accession 209703). The large slow-moving governor, requiring a place at once accessible to the

drive train and removed from the bystander, had to be mounted a great distance away from the throttle valve, connected by linkages hidden under the frame of the machine. Later in the career of the engine, the original governor was replaced by a spring-loaded governor forming an integral unit with the throttle valve. The present arrangement is a conjectural reconstruction of the original governor, executed in the Museum's shops in 1965.

Further examples of similar governors of traditional design are, briefly, those of the steam engine model of 1838 marked "Bancks, 441 Strand, London, fecit" (NMHT 316139; Accession 225132), and the cutaway engine model (Figure 6), used for classroom demonstration at Johns Hopkins University (NMHT 322259; Accession 246694; marked "P. D. Lugenbeel, 1860"). Also probably used for purposes of demonstration was the simple kinematic model of a centrifugal pendulum (NMHT 261315; Accession 51116; unmarked; steel, 14"×10").

Automatic Cutoff Control

In the middle of the nineteenth century, after Watt's governor had remained essentially unchanged for the first half century of its existence, the question of steam engine regulation was reexamined. In hundreds of new patents, modifications of every feature of the governor were suggested. The first improvement of importance, however, did not affect the governor itself but its final control element, the valve gear. Traditionally the governor regulated the engine speed by adjusting a throttle valve that changed the flow rate of the live steam entering the engine. The throttle valve thus purposely caused a pressure drop, that is, a loss in available energy. The inefficiency of this method was eventually recognized, and inventors explored a more economic alternative; instead of supplying the steam continuously at reduced pressure, it was suggested that it be supplied at full pressure, intermittently, during only part of the stroke. The first step in this de-

6. *Early Engineering Reminiscences (1815-1840) of George Escot Sellers*, ed. Eugene S. Ferguson, United States National Museum Bulletin 238 (Washington, D.C., 1965), pp. 181-182, fig. 78.

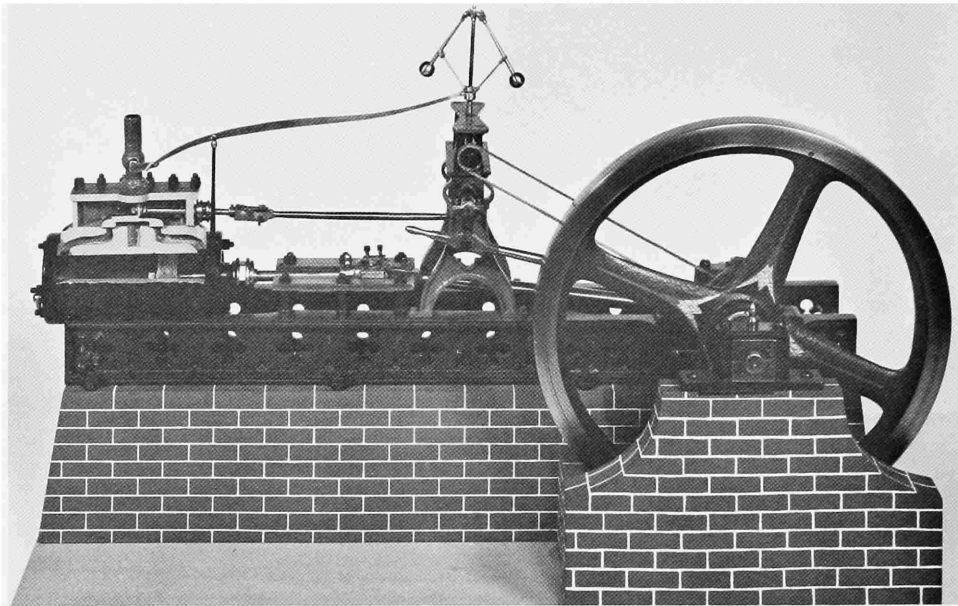

FIGURE 6.—Cutaway model of a conventional nineteenth-century steam engine showing the governor linked to a throttling valve mounted directly on the valve chest. (NMHT 322259. Smithsonian photo P-63299-A.)

velopment was to construct valve gear that permitted the supply of steam to the cylinder to be cut off at some point before the end of the work stroke and to make this point variable. At low load the point of cutoff was adjusted to occur sooner than under heavy load. Since the steam in the cylinder was permitted to expand between cutoff and exhaust, it could deliver more work. The second step was to make the point of cutoff automatically adjustable by the governor. Solutions to this problem were proposed in numerous schemes by such inventors as Zachariah Allen in 1834, and Horatio Allen, J. J. Meyer, and F. E. Sickels, all in 1841.⁷

The first truly successful automatic cutoff valve gear was built by George Henry Corliss (1817–1888) of Providence, R. I., in 1848. The application for his basic patent (U.S. Patent 6162 of 10 March 1849) was accompanied by a patent model, now in our Museum, that was patterned after a walking beam engine which he had actually built in

1848 for the Wamsutta Mills in New Bedford, Mass. (NMHT 308646; Accession 89797; walnut, 24"×6"×22").⁸ Figure 7 shows the steam cylinder on the right with the horizontal stems of the inlet and exhaust valves, both at top and bottom; in the center is the governor, underneath it is the detaching mechanism, and farther below is the wrist plate which is driven in a rocking motion by an eccentric on the crankshaft (left).

Like all successful early cutoff mechanisms, the Corliss arrangement is a *detachable* (also termed *releasing* or *drop-off*) cutoff gear—in contrast to the more recent *positive cutoff*, as on the Porter-Allen engine—and it affects only the inlet valves, while the cycle of the exhaust valves is fixed. The governor is not positively connected with the inlet valves; but by means of an ingenious trigger mechanism it can disconnect the linkage that opens the inlet valve at an earlier or later

7. Conrad Matschoss, *Die Entwicklung der Dampfmaschine*, 2 vols. (Berlin, 1908), I:466–473; II:1–9.

8. Frank A. Taylor, *Catalogue of the Mechanical Collections of the Division of Engineering, United States National Museum, Smithsonian Institution, United States National Museum Bulletin 173* (Washington, D.C., 1939), pp. 71–72, pl. 17:2.



FIGURE 7.—George H. Corliss's patent model of 1849 describing his basic patent of automatic cutoff control. (NMHT 308646. Smithsonian photo 31694.)

point during the engine stroke. If the engine runs too fast, the governor releases the inlet valve earlier thus admitting less steam; if the engine runs too slowly, say due to an increase in load, conversely more steam is admitted.

Subsequently Corliss took out numerous further patents on releasing mechanisms which varied only in detail. Their basic principle can be studied best on the model of a Corliss cutoff valve with governor (Figure 8), dating probably from the 1860s (NMHT 309817; Accession 109438; unmarked; bronze and steel, 24"×9"×17").⁹ The exceptionally well-made operational model, apparently not a patent model, was presented in 1930 by the Franklin Machine

Company, Providence, R.I., a successor to the former Corliss Engine Works. Details on purpose and history of the model are unknown. Perhaps it was used in sales or in patent litigation as an illustration of the Corliss automatic cutoff control. (It seems to form a set with another model representing a thoroughly conventional throttle valve governor: NMHT 309818; Accession 190438; Figure 9).¹⁰ Figure 8 shows in the middle the crank-operated governor, on the far left the slide valve (in closed position), to its right a dashpot, and in the middle below the governor the releasing mechanism. The slide valve is connected with a coil spring hidden underneath the frame, which on release closes the valve. The dashpot softens

9. *Ibid.*, pp. 74-75.

10. *Ibid.*, p. 79

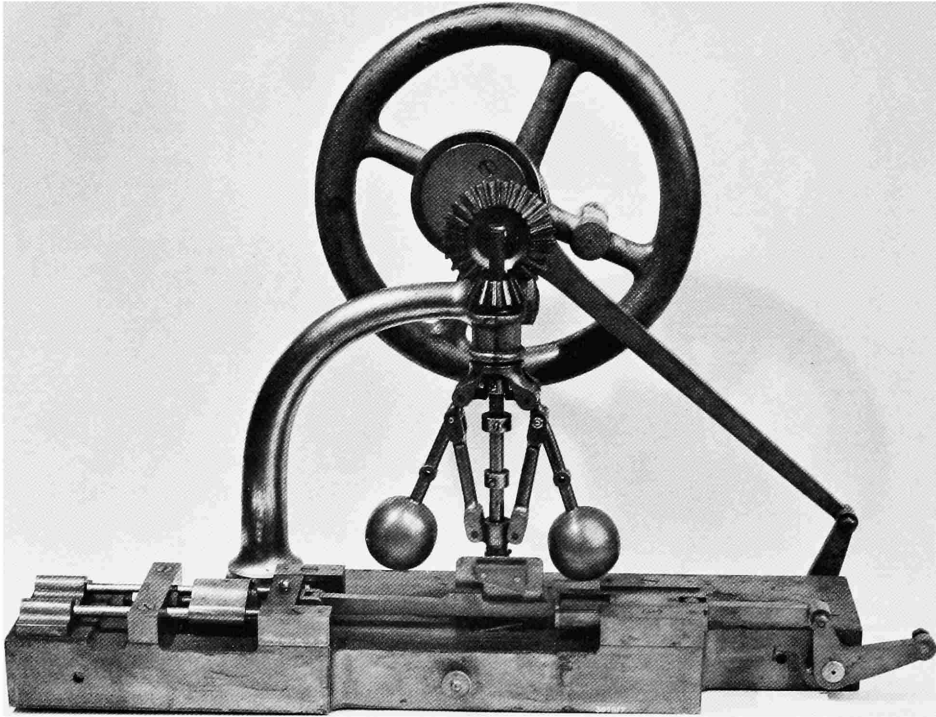

FIGURE 8.—Model demonstrating automatic cutoff control, probably made at the Corliss Engine Works. (NMHT 309817. Smithsonian photo 44533-B.)

the impact of this motion. Slightly to the right of the center is a block which is kept in a horizontal reciprocating sliding motion by the eccentric (top) through the linkages on the far right. Pressed upward by a leaf spring, the horizontal rod (bottom center) latches from below into the sliding block, transmitting the reciprocating motion to the slide valve. The governor is equipped to cut this motion of the valve short. When with increasing speed the arms of the pendulum rise, the inclined block under the governor slides downward in proportion, entering the path of a cam on the reciprocating connecting rod. As the cam strikes the inclined block, it is pushed downward, disengaging from the sliding block, thus cutting short the travel of the slide valve. The farther the inclined block extends downward, the earlier the moment of cutoff will occur, accordingly admitting less steam to the cylinder and decelerating the engine.

From the great number of automatic cutoff mechanisms that Corliss had invented and patented, a standard arrangement finally emerged which, from the last quarter of the nineteenth century on, was adopted by many American steam engine builders. In our Museum this is represented, besides a number of engine models, by a full-scale steam engine.

Built around 1885 by Jacob Naylor at the "People's Works" in Philadelphia, this horizontal engine (Figure 10) served as the prime mover for a school machine shop (NMHT 314818; Accession 210004; about 50 hp at 60 r.p.m. and 75 p.s.i.). Still a low-speed engine, betrayed by the large size of the conventional governor (each pendulum arm is two feet long), it is equipped with Corliss cutoff gear of late design, where the original sliding blocks have been replaced by rotary knockoff cams concentric with the steam valve spindles. In the usual fashion,

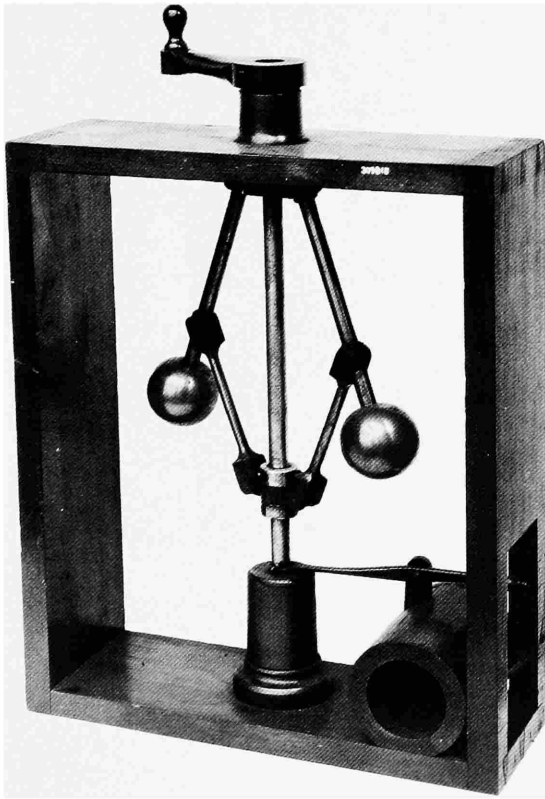

FIGURE 9.—Model demonstrating conventional throttling control, probably made at the Corliss Engine Works. (NMHT 309818. Smithsonian photo 44576.)

the cutoff gear is located on the side of the engine cylinder (Figure 10). The four valves, all of rotary design, are actuated by the circular wrist plate, which is maintained in a rocking motion by the eccentric through a horizontal connecting rod. The exhaust valves at the bottom of the cylinder are positively connected with the wrist plate, while the inlet valves are actuated only indirectly through the releasing cutoff mechanism. The two conspicuous dashpots below have the function of cushioning the closing movement of the inlet valves.¹¹

11. Robert Henry Thurston, *A History of the Growth of the Steam Engine*, 2nd edition (New York, 1884), pp. 319–321.

Further examples of Corliss cutoff control are the following engine models:

1. Model of a horizontal Corliss mill engine (NMHT 327675; Accession 268278; bronze and steel, $41\frac{1}{2}'' \times 16'' \times 16''$), built in the 1870s at the Corliss Engine Works for purposes of demonstration and promotion. It is equipped with a fully operational governor-controlled cutoff with crab-claw releasing gear.
2. Model of a horizontal Reynolds-Corliss engine as manufactured in the 1890s by the Edw. P. Allis Co. of Milwaukee, built around 1900 by Howell M. Winslow (NMHT 311991; Accession 157370; scale $1''=1'$).
3. Model of an unspecified horizontal Corliss engine (NMHT 329211; Accession 279374; overall size $19'' \times 38'' \times 23\frac{1}{2}''$; marked "Built by Harry H. Catching, Lexington, Ky., 1958: A Hobby Project"). Governor and automatic cutoff gear are fully operational.
4. Model of a large Corliss double pumping engine of 1870, a forerunner of the famous Centennial engine of 1876.¹² The model was reportedly built at the Corliss Engine Works (NMHT 309820; Accession 109438; scale $1''=1'$). Each side of the engine is controlled by a separate governor, acting on its own cutoff gear.

As engines equipped with automatic cutoff control were 30% to 50% more efficient than comparable conventional ones, Corliss's patents proved to be extremely lucrative. They were promptly contested by the steam engine builders, Thurston, Greene & Co., also of Providence, Rhode Island, who had acquired the rights to F. E. Sickels's patents, and who involved Corliss in an extended suit of patent litigation. A courtroom exhibit (Figure 11) of Corliss's opponents is the model of a Greene automatic cutoff engine of 1857 (NMHT 316013; Accession 223475; $37\frac{1}{2}'' \times 17\frac{3}{4}'' \times 29\frac{3}{4}''$; 6" stroke; brass and steel). It bears a brass plate reading: " $\frac{1}{2}$ Hp model of Greene steam engine built by Ben-

12. Taylor, *Catalogue of Mechanical Collections*, pp. 75–76, pl. 18:1.

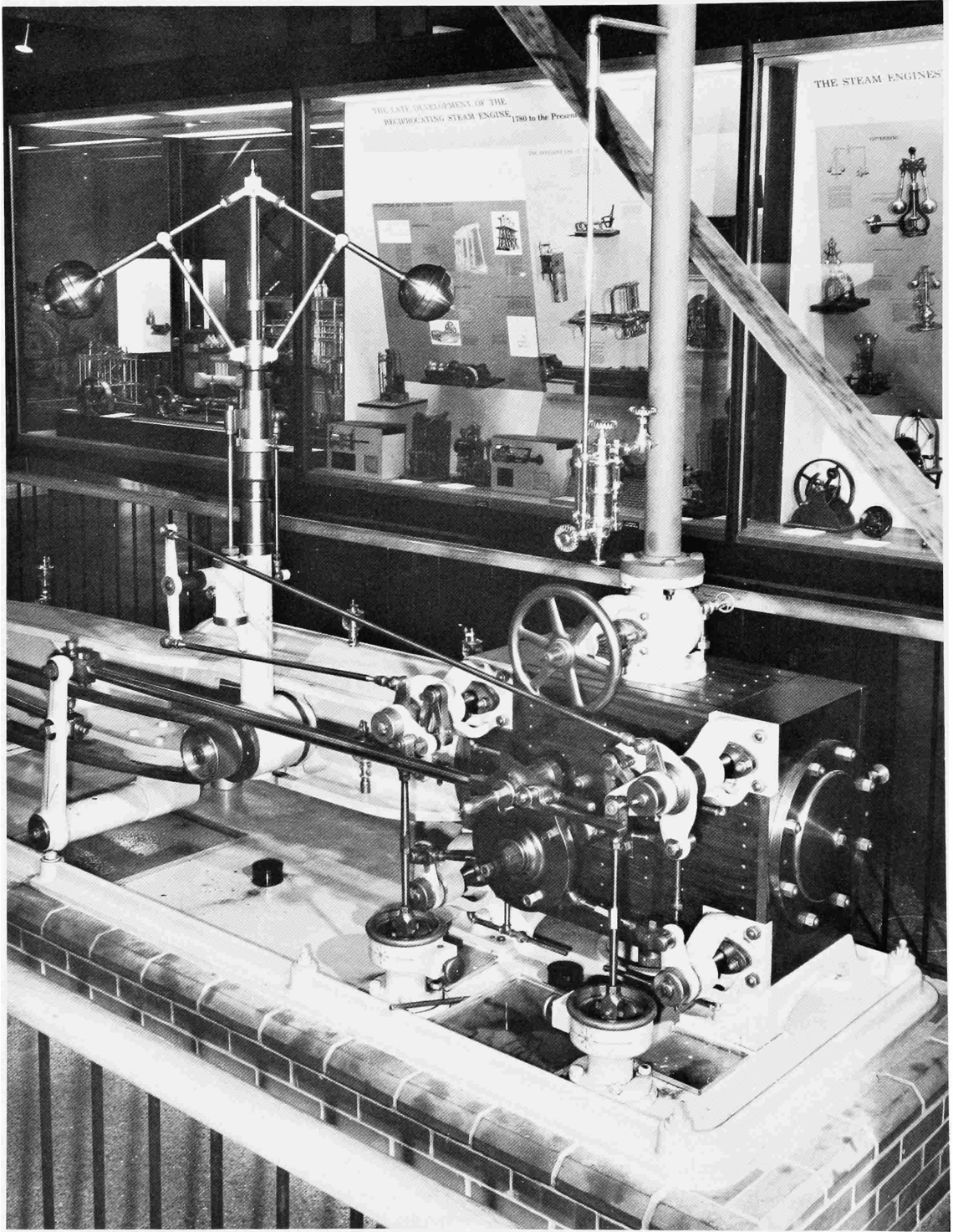

FIGURE 10.—Corliss-type steam engine built about 1885 by Jacob Naylor at the "People's Works" in Philadelphia. The photograph shows the connections between the governor and the releasing cutoff gear mounted to the side of the cylinder. (NMHT 314818. Smithsonian photo 72170.)

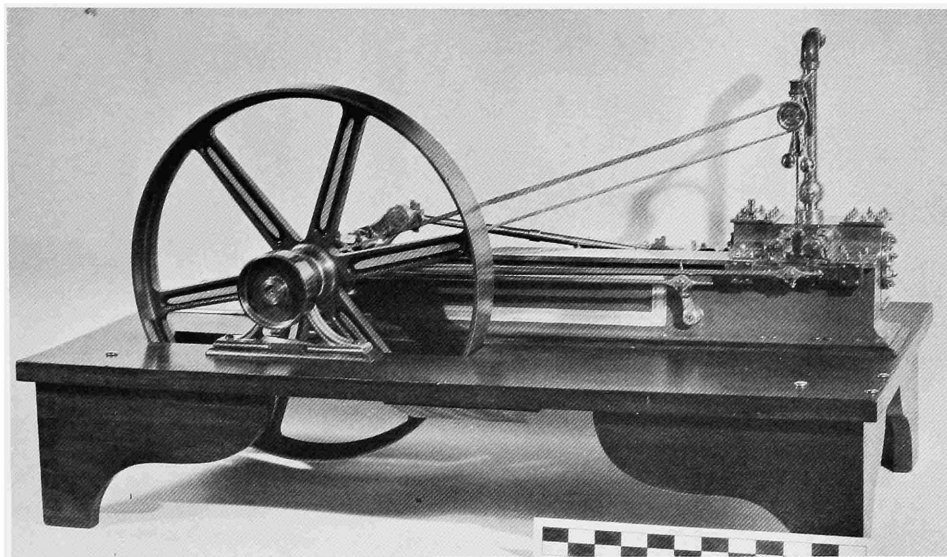

FIGURE 11.—Model of a Greene steam engine used as a courtroom exhibit in patent litigation between Corliss and Greene, 1857. (NMHT 316013. Smithsonian photo 45519-A.)

jamin Francis Thurston, Patent Att'y 1829–1890. Used to familiarize himself with all technical details involved in the so-called Corliss Steam Engine Cutoff Cases.” Noble T. Greene had in 1855 introduced an automatic cutoff gear similar in effect to that of Corliss but different in the mechanical execution. B. F. Thurston represented Greene in the ensuing protracted and costly litigation which ended with an injunction against the Greene engine effective up to 1869.¹³

An NMHT exhibit label describes the operation of the Greene cutoff as follows:

In Greene's engine, latches on a sliding bar driven by the steam eccentric opened the steam valves as the bar moved to and fro. The latches had a slight vertical movement, controlled by the governor; the higher the latches, the longer they held the valves open. A separate eccentric drove the exhaust valves so that the steam eccentric could be set to allow cutoff almost to the end of the stroke. (With a single eccentric, cutoff cannot occur after about half stroke).

The governor on this model was reconstructed in the 1930s at the Brown University Machine Shop under supervision of Professor Wm. Kenerson.

13. Thurston, *History of Steam Engine*, pp. 321–323.

Charles T. Porter's Loaded Governor

The invention of Corliss's automatic cutoff gear had left the traditional governor unchanged. The first significant improvement to the governor itself since its invention was the work of an outsider in the engineering profession. Charles T. Porter (1826–1910) of New York, who became famous as “the father of the high speed steam engine,” was by training a lawyer. One of his first inventions, the revolutionary “loaded governor” (1858), was made quite intuitively. In his memoirs, Porter has referred to this as “the surprising combination of sensitiveness and stability in the action of this governor which has led to its general use, and at which I myself have never ceased to wonder because I was ignorant of its cause.”¹⁴

On the traditional governor, the centrifugal motion of the revolving flyballs serves as a measure of speed. According to the laws of the centrifugal pendulum, the displacement of the flyballs is a function only of speed and is independent of the mass of the balls. The function is nonlinear: the ratio between dis-

14. Charles Talbot Porter, *Engineering Reminiscences* (New York, 1908), p. 23.

placement and speed, that is, the governor sensitivity, decreases with rising speeds. A simple calculation can show that the optimum range of operation of the traditional governor lies at speeds well below 100 r.p.m.¹⁵ Such slow-moving pendulums possess little kinetic energy—i.e., little power for the control action—unless the balls are made very heavy. Increases in inertia, however, slow down the system's response to disturbances, at the cost of stability as well as accuracy. Lack of responsiveness was indeed the main shortcoming of the traditional pendulum governor.

On his governor, Porter sharply reduced the size of the flyballs and increased instead the speed by a factor of approximately ten. Thus he obtained a governor motion that was at once powerful and responsive. To make the device sufficiently sensitive, he balanced the centrifugal forces by a counterweight which was at first mounted nonrotating from a lever, later arranged in the characteristic manner concentrically on the governor spindle. The sensational improvements in stability and steady-state accuracy of Porter's governor soon forced all other manufacturers of governors to review their designs.¹⁶

The model of C. T. Porter's first loaded governor, 1858 (NMHT 251289; Accession 48865; U.S. Patent 20894 of 13 July 1858; 11"×12"×12"; brass and steel), was submitted to the U.S. Patent Office as part of Porter's patent application.¹⁷ Figure 12 shows clearly the above-mentioned features. In contrast to Porter's commercial model where the counterpoise is located on the governor's axis of rotation, here the weight is arranged on the lever connecting the governor with the steam valve.

Porter's loaded governor in its standard form can be seen on the high-speed Porter-Allen steam engine (Figure 13), 1881 (NMHT 315891; Accession 222964; full-size

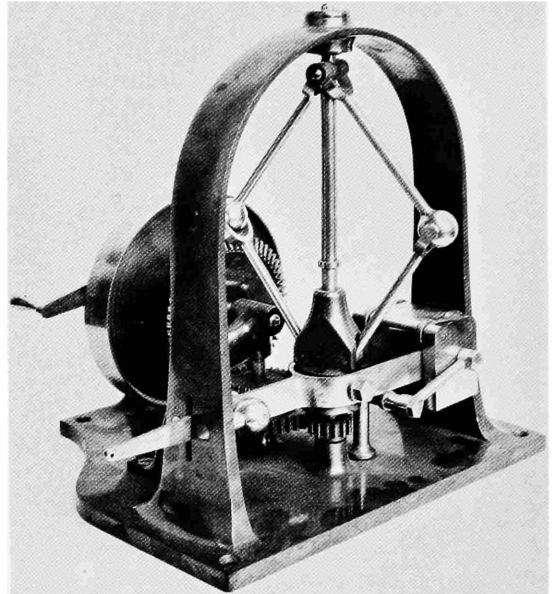

FIGURE 12.—Patent model of Charles T. Porter's loaded governor, 1858. The counterpoise is on the right of the horizontal lever, not in the familiar manner on the governor axis. (NMHT 251289. Smithsonian photo 30368.)

engine of 80 hp at 300 r.p.m.), which was installed as one of eight in Philadelphia's first electric company, the Brush Electric Light Co., to drive an electric generator for street lighting.¹⁸ The governor's most characteristic feature, the central counterpoise, rests loosely on the axis, so that its angular inertia will not retard the governor's responses to sudden load changes. Besides the governor, the most notable feature of the Porter-Allen high-speed engine is the automatic cutoff gear patented by John F. Allen in 1862.¹⁹ In contrast to the release cutoff as used by Sickels and Corliss—unsuitable for high speed because for valve closure it requires a fixed amount of time independent of engine speed—in Allen's gear the variable cutoff is positively controlled. The governor acts on a sliding link between eccentric and steam valve which can vary the length of

15. Robert Henry Thurston, *A Manual of the Steam Engine*, 3rd ed., 2 vols. (New York, 1897), II:378.

16. Porter, *Engineering Reminiscences*, pp. 16–33.

17. Taylor, *Catalogue of Mechanical Collections*, pp. 81–82.

18. Porter, *Engineering Reminiscences*, pp. 42–57, 304–305.

19. Matschoss, *Entwicklung der Dampfmaschine*, II:193–199.

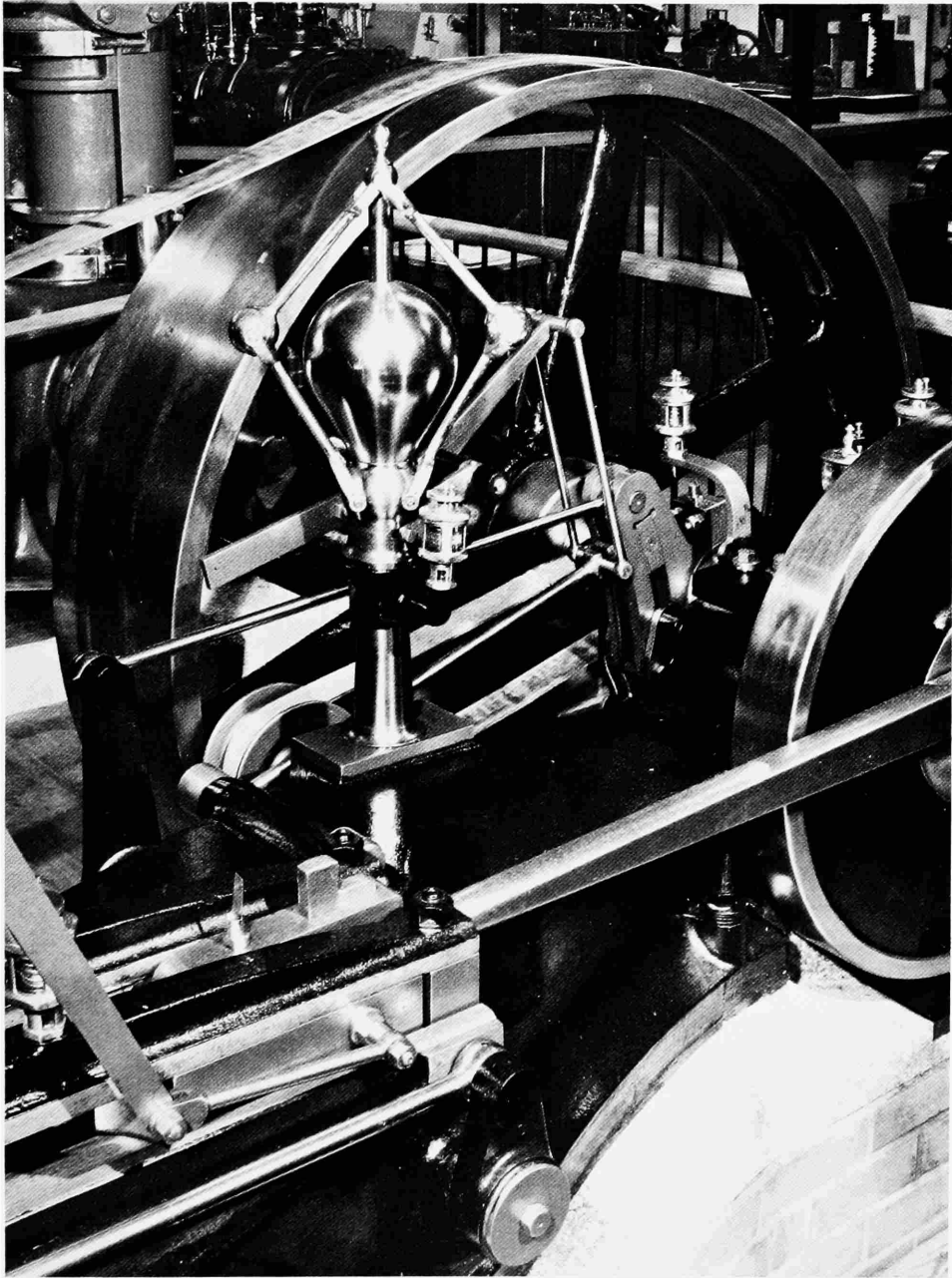

FIGURE 13.—Porter-Allen high-speed steam engine, 1881. The Porter governor with its characteristic central counterpoise varies the stroke of the eccentric by adjusting the link to the right of the governor. (NMHT 315891. Smithsonian photo 72176.)

valve travel. The speed of the valve motion is therefore directly dependent upon the engine speed.

The influence of Porter's invention was by no means limited to America. A European

version of the loaded governor can be seen on a steam engine built by Sulzer Brothers, Winterthur, Switzerland, in 1884. The engine is part of a steam-driven Linde-Wolf refrigeration compressor (NMHT 328660; Accession

274467). The governor is not only loaded by a large weight on its axis but also by a stack of small weights at the end of a lever below the governor. The controlled engine speed can be adjusted by adding or removing these weights. The governor acts on releasing-type automatic cutoff gear.

Another engine in the Porter-Allen tradition, although it lacks the typical Porter governor, is the steam pumping engine designed by Erasmus Darwin Leavitt for the Louisville, Kentucky, waterworks. In order to make the governor sufficiently powerful in spite of the extremely low engine speed (18 r.p.m.) the governor is geared to run at four times the engine speed, and, unlike the Porter governor, it has no central weight but two heavy flyweights instead. An external lever connects the governor with a dashpot. The desired speed can be adjusted by suspending weights from this lever. The output lever of the governor controls, through appropriate linkages, the lead angle of the camshaft which, in turn, actuates the valves on both cylinders of the engine. The Louisville pumping engine is represented in the Museum not only by a fully operational 12:1 model (NMHT 324000; Accession 254418; built 1963 by Harry H. Catching), but also by a set of original engineering drawings (NMHT 320975) prepared between 1884 and 1892 under the direction of E. D. Leavitt and C. Hermany.

In exceptional cases, steam engine governors also were equipped with hydraulic servomotors. This is illustrated by the model of the gigantic 7500 hp double-compound steam engine, built 1902–04 by Allis-Chalmers, generating electricity for the Interborough Rapid Transit subway of New York (NMHT 320023; Accession 242871; model built by Severn-Lamb, Ltd., 1960–62). The model shows a Porter governor acting on Corliss-type variable cutoff gear through a hydraulic servomotor. A second governor, of similar form but direct-acting, serves to prevent overspeed. An actual specimen of this overspeed governor is in the collection (NMHT 315709; Accession 197529). The original servo-powered governor shown in the model

was later replaced by a more modern Allis-Chalmers hydraulic servo regulator which is also in the collection (NMHT 315708; Accession 197529; size 5'5" [over drive shaft] \times 30' \times 4'8"; see drawing Allis-Chalmers 481-163 of 1-11-1962).

Mid-Nineteenth Century Patent Models

A successful invention as Porter's governor had hundreds of competitors. A striking feature of nineteenth-century American technology is the enormous outburst of inventive energy. Engine governors were only one subject of many to which Yankee inventors devoted their ingenuity, but their examples illustrate the phenomenon clearly enough. Between 1836 and 1902, the number of United States patents granted for speed-governing devices—not counting shaft governors—is far in excess of one thousand. Up to the 1880s, the United States Patent Office required each patent application to be accompanied by a model of the invention; when the huge collection of patent models that had thus accumulated was reduced in 1908 and liquidated in 1926, the Smithsonian Institution had first choice in selection of models. The patent models of governors described herein represent only a small and selected sample of the ingenuity concentrated on the subject of speed control. The models contain a great diversity of ideas, some of which proved impractical while others anticipated designs that were successful later on. The following patent models are described in chronological order.

The earliest of these models (Figure 14) represents the U.S. Patent 8447 entitled "Apparatus for Regulating the Speed of Engines" of H. A. Luttgens, granted on 21 October 1851 (NMHT 251288; Accession 48865; steel and brass; $6\frac{3}{4}$ " \times 9" \times 14 $\frac{1}{2}$ "; the crank is inscribed "H. A. Luttgens").²⁰ It is a complicated mechanism exhibiting—for the first time within the limits of our collections—three different innovations: (1) it provides

20. Taylor, *Catalogue of Mechanical Collections*, pp. 80–81.

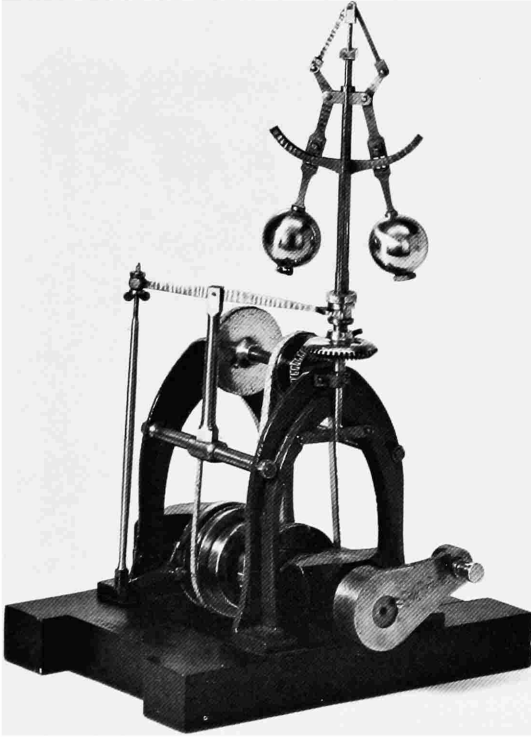

FIGURE 14.—Patent model of steam engine governor by H. A. Luttgens, 1851. (NMHT 251288. Smithsonian photo 69392.)

positive cutoff control by varying the throw of the eccentric, anticipating the more successful Porter-Allen engine of ten years later; (2) it contains a mechanical servo-power drive, by which the energy for the control action is supplied not by the governor itself but by the crankshaft of the engine; (3) it employs the *integral* or *reset* mode of control.

A conventional flyball governor is mounted on a structure holding two parallel horizontal shafts one above the other, of which the lower one is the crankshaft of the engine. The variable-throw eccentric is mounted below the governor directly on the crankshaft. The shafts are connected by two drive belts and two pairs of pulleys. The belt on the governor side serves to drive the upper shaft and, through a pair of bevel gears, the governor. The other belt, driven from above by a slightly larger pulley, runs at a somewhat higher speed. Through a friction clutch

it drives the outer part of a planetary gear transmission on the crankshaft, which is also acted upon by a belt brake connected with the output lever of the governor. A complicated mechanism on the crankshaft, of which this planetary gear transmission is part, drives, through a pair of small bevel gears, the eccentric from and to the shaft. The direction of this motion depends on the resultant of the opposing torques produced by the friction clutch and the brake or, indirectly, on the position of the governor. When the brake is not engaged, the friction clutch tends to drive the transmission forward in such a direction as to reduce the throw of the eccentric, which results in a later cutoff and hence acceleration of the engine. On the other hand, at excessive speed, the rising governor balls will actuate the brake, producing a torque in the opposite direction, which will increase the throw of the eccentric. Equilibrium will be established when, both torques being equal, the throw of the eccentric will remain constant.

As already mentioned, one of the novelties of this governor is the application of the *integral* mode of control. On the classical governor a difference between actual and desired speed leads to a change in valve position. This governor, in contrast, responds to an error not by a one-time adjustment but by an adjusting movement that continues until the steady-state error has disappeared. Corrective action is proportional not to the error (as in *proportional control*) but to the time integral of the error. *Integral* control then has the advantage of high steady-state accuracy, which is offset, however, by poor dynamic behavior. In later years it has become popular only in combination with *proportional control*. Nothing is known of the practical fate of Luttgens' governor.

The invention described in the patent for a "Governor for Steam Engines" of G. S. Stearns and W. Hodgson, 1852 (NMHT 251287; Accession 48865; U. S. Patent 9236 of 31 August 1852; steel and brass; 6"×13"×17"), is of a comparatively simple nature

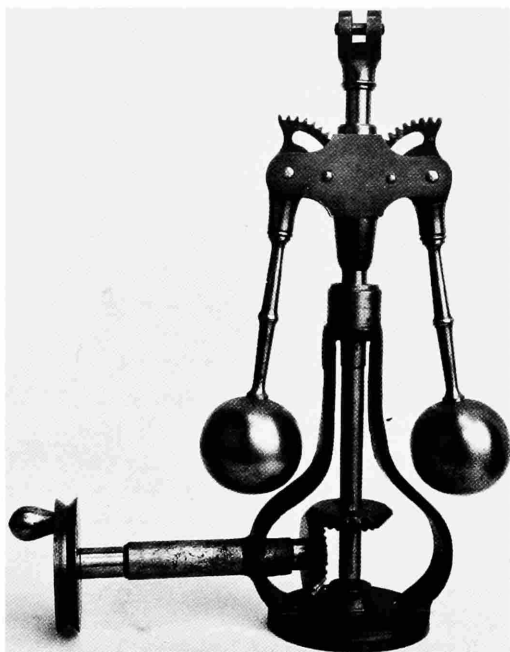

FIGURE 15.—Patent model of steam engine governor by G. S. Stearns and W. Hodgson, 1852. (NMHT 251287. Smithsonian photo 30367.)

(Figure 15).²¹ In it the motion of a traditional centrifugal pendulum is transmitted by rack and pinion rather than by the usual pivoted levers. The advantages claimed for this design are simplicity and cheapness.

An invention of much greater significance is represented by the patent model of Thomas Silver's marine steam engine governor (Figure 16) of 1855 (NMHT 325611; Accession 249602; iron and wood; 9" diam. × 12" high; with brass plate "Tho's. Silver Philad'a.").

All the governors encountered in this collection so far work by taking for each particular speed a distinct position in which the centrifugal force on the flyballs is balanced by gravity forces. This reliance on gravity has an obvious disadvantage, for such gravity governors can operate only when mounted vertically on a platform that is free from any accelerations. Demands for a governor independent of the orientation of its axis first

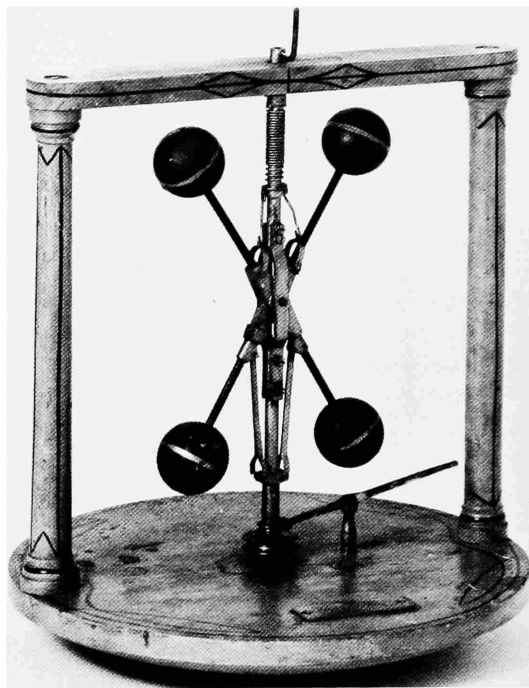

FIGURE 16.—Patent model of Thomas Silver's marine steam engine governor, 1855 (NMHT 235611. Smithsonian photo 69390.)

arose in connection with marine steam engines. On a rolling and pitching ship the traditional gravity governor was clearly useless, whereas ungoverned marine engines had a dangerous tendency to race whenever the propeller or paddle wheel was lifted out of the water in heavy seas.

One of the earliest marine steam engine governors was invented by Thomas Silver (1813–1888)²² of Philadelphia (U.S. patent 13202 of 3 July 1855). In order to eliminate gravity effects, Silver first simply extended the two arms of the conventional pendulum upward, and at the upper ends of these arms he added symmetrically two other flyballs to balance out the weight of the original ones. Second, he connected the governor slide to a helical spring mounted concentrically on the governor axis. This spring served to counteract the centrifugal forces. Silver had

21. *Ibid.*, p. 81.

22. *Dictionary of American Biography*, under "Silver, Thomas."

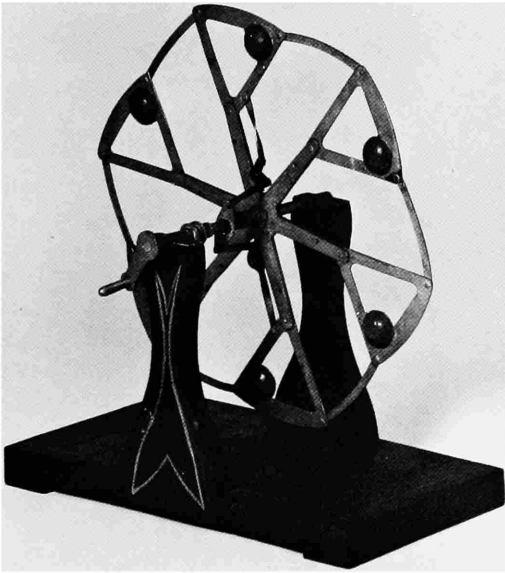

FIGURE 17.—Patent model of H. N. Throop's governor for marine steam engines, 1857. (NMHT 325612. Smithsonian photo 69388.)

considerable success²³ with this invention and its subsequent elaborations. His governor was used on numerous merchant steamers; it was adopted by the navies of France and Britain, but not by the United States Navy.

A spring-loaded marine governor, too, is the "Governor for Steam Engines" of H. N. Throop (Figure 17), 1857 (NMHT 325612; Accession 249602; U.S. Patent 18997 of 29 December 1857; iron and wood, $9\frac{1}{2}'' \times 5\frac{1}{2}'' \times 10\frac{1}{2}''$, unmarked). Gravity forces are neutralized by symmetric mounting of the flyballs, while a spring on the axis provides the centripetal force. The playful appearance of the device conceals a feature of remarkable subtlety. The patent specification explains:

It will be observed that in my governor the weights do not move out from and into the axle in a radial line; but in moving out, they fall back of such a line to any desired extent, depending on the arrangement of the spring or springs and the length of the connections, or in other words, depending on the limits pre-

scribed for the weights to move in, toward and from the axle. If the paddle wheel or screw to which an engine is attached is, by the uneven surface of the water and the plunging of the vessel, suddenly and frequently thrown out of the water, as is often the case, leaving no resistance to the power and motion of the engine, except the inertia of the wheels or screw, the motion of the engine and the spindle of the governor is instantly increased; but the weights of the governor, on account of their inertia, will not readily participate in such increased motion, consequently they are left behind or fall back of the radial line, with a movement outward, aided in some degree by the centrifugal force due to the increased motion of the engine; thus instantly closing the valve.

The governor's action is based on two separate physical effects. Centrifugal force displaces the flyballs outward in proportion to engine speed. In addition to this radial motion, the flyballs are also capable of tangential motion when the engine is decelerated or accelerated. The resulting governor action then is proportional to the speed itself and to the rate of change of speed (i.e., the first derivative of speed with respect to time), a characteristic known in modern control engineering as "proportional plus derivative response." In employing inertia effects, Throop's governor anticipates the shaft governors popular at the end of the nineteenth century.

The patent model representing the "Im-

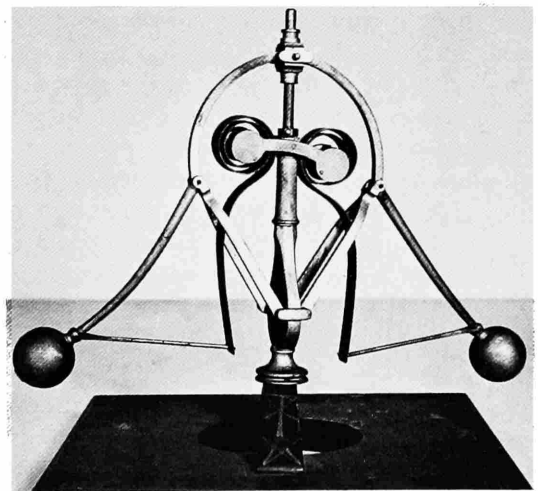

FIGURE 18.—Patent model of S. H. Miller's steam engine governor, 1860. (NMHT 325613. Photo CLG.)

23. Thurston, *Manual of Steam Engine*, II:391.

provement in Governors for Steam-Engines" of S. H. Miller, 1860 (NMHT 325613; Accession 249602; U.S. Patent 29986 of 11 September 1869; steel, brass, and wood, 9" × 9" × 10"), again belongs to the class of spring-loaded marine governors capable of operating in any axial position (Figure 18). It is a governor of basically conventional design. Leaf springs oppose the centrifugal forces on the flyballs which are arranged to travel on a linear radial path.

The patent model of the steam engine governor (Figure 19) of Oliver A. Kelley and Estus Lamb, 1865 (NMHT 308667; Accession 89797; U. S. Patent 46111 of 31 January 1865; steel and brass, 6" diam. × 12" high; marked "Oliver A. Kelley & Estus Lamb, 1864"), is remarkable not only for the exquisite quality of its construction but also for the concept it embodies.²⁴ It represents an early—within this collection the first—governor combining the superior dynamic behavior of *proportional* control with the high steady-state accuracy of the *integral* response (discussed earlier in connection with the Luttgens governor, Figure 14). Since this feat is accomplished by purely mechanical means, the governor is somewhat complicated. The proportional action is obtained in the same way as on a conventional governor. A sleeve linked to the flyball in the usual way slides up and down on the governor shaft in proportion to engine speed. An arm attached to this sleeve reaches out through a slot in the casing of the governor. This arm is connected to a vertical spindle carrying on its threaded lower part a nut attached to the arm moving the valve. Thus the valve is moved directly in proportion to the position of the flyballs. Superimposed to this motion is another more complicated one. The vertical spindle is connected through a pair of bevel gears to a ratchet wheel, which when rotated will drive the nut on the spindle up or down, thus moving the valve without further change in position of the flyballs. By an intricate triggering device, connected to

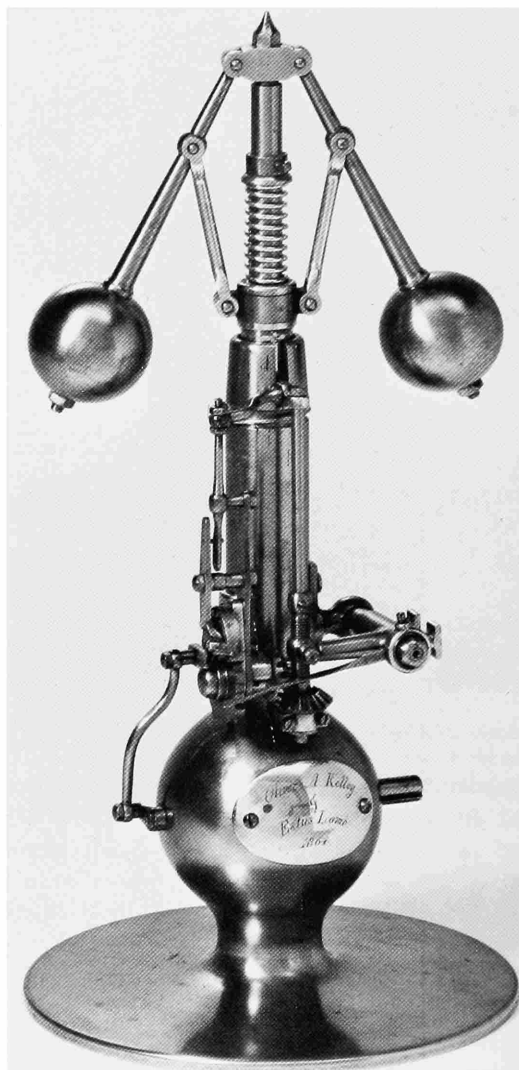

FIGURE 19.—Patent model of steam engine governor by Oliver A. Kelley and Estus Lamb, 1864. (NMHT 308667. Smithsonian photo 69391.)

the sliding arm of the governor through an S-shaped cam, the ratchet wheel is driven forward or backward according to whether the engine runs too slow or too fast. The governor will respond to a disturbance immediately by proportional action; the remaining steady-state error will set the ratchet wheel in motion, driving the nut up or down along the spindle until the steady-state error is eliminated. The governor of Kelley and

²⁴ Taylor, *Catalogue of Mechanical Collections*, p. 82.

Lamb is in conception quite rational, indeed it anticipates a form of control very common nowadays. Whether it had practical success is not known.

The advantages claimed by the patent specification for the "Improvement in Steam-Engine Governors" of T. S. La France, 1866 (NMHT 325614; Accession 249602; U.S. Patent 56956 of 7 August 1866; simple wooden model; 5"×7"×13"; marked "T. S. La France. Elmira N.Y."), are simplicity and cheapness of construction. A loaded governor with two small flyballs and a large central counterpoise on its axis (Figure 20), it is

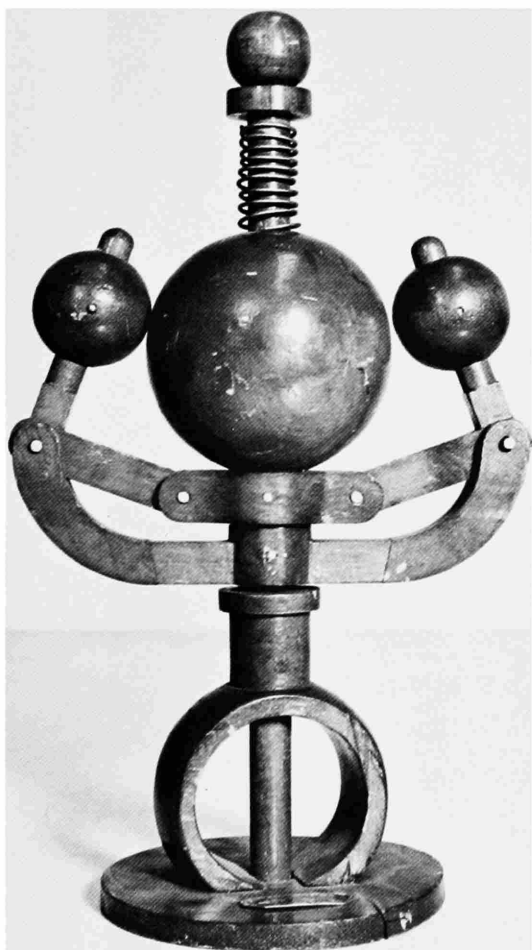

FIGURE 20.—Patent model for steam engine governor by T. S. La France, 1866. (NMHT 325614. Photo CLG.)

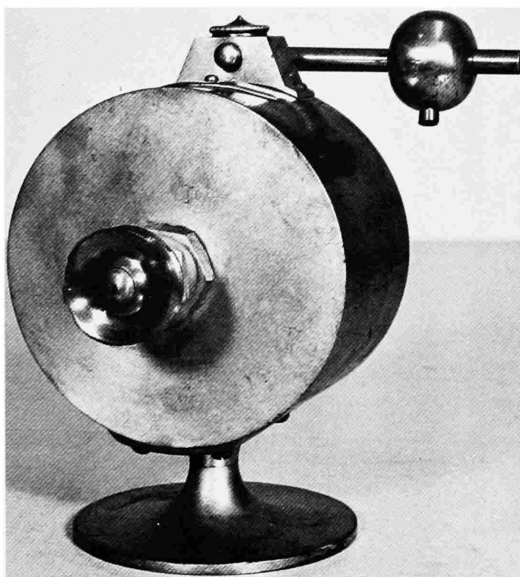

FIGURE 21.—Patent model of Andrew J. Peavey's vane governor, 1870. (NMHT 308678. Photo CLG.)

clearly inspired by Porter's governor from which it differs only in the arrangement of mechanical connections, and in that it is additionally loaded by an axial helical spring.

Late in the nineteenth century a new class of governors became popular that employed various hydraulic rather than purely mechanical effects as their method of sensing speed. One of these is represented in the patent model (apparently a full-scale prototype) of the vane governor (Figure 21) of Andrew J. Peavey, 1870 (NMHT 308678; Accession 89797; U.S. Patent 106400 of 16 August 1870; steel and brass, 5"×6"×7½"; marked: "ANDREW J. PEAVEY. BOSTON, MASS.")²⁵ Its design is based on the assumption that the drag on an object immersed in a moving fluid is proportional to the relative velocity. The governor (Figure 22) consists of a closed cylinder in which oil is set into motion by a paddle wheel driven at a speed proportional to that of the engine. The oil impinges against a gravity-loaded vane immersed in it, which is deflected from its rest position by an angle proportional to

25. *Ibid.*, pp. 82–83.

A. J. Peavey,

Governor.

No. 106,400.

Patented Aug. 16, 1870.

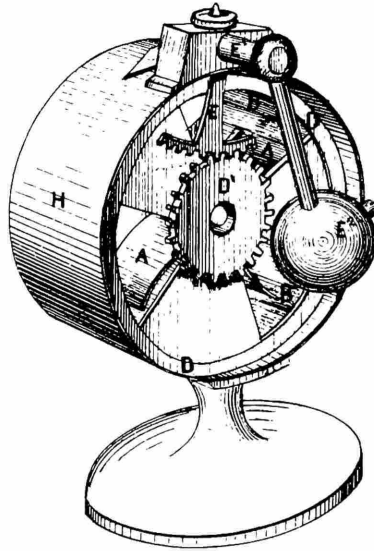

Fig. 1

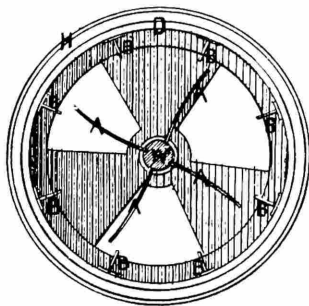

Fig. 2

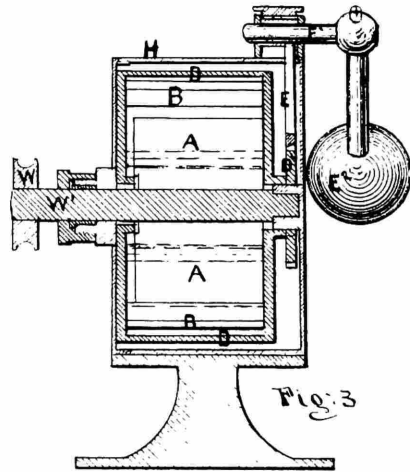

Fig. 3

Witnesses *Frank L. Parker*
Alfred Jones

Inventor.
Andrus J. Peavey

FIGURE 22.—The interior of A. J. Peavey's vane governor. Reprinted from U. S. Patent No. 106400 of Aug. 16, 1870, Patent Specifications.

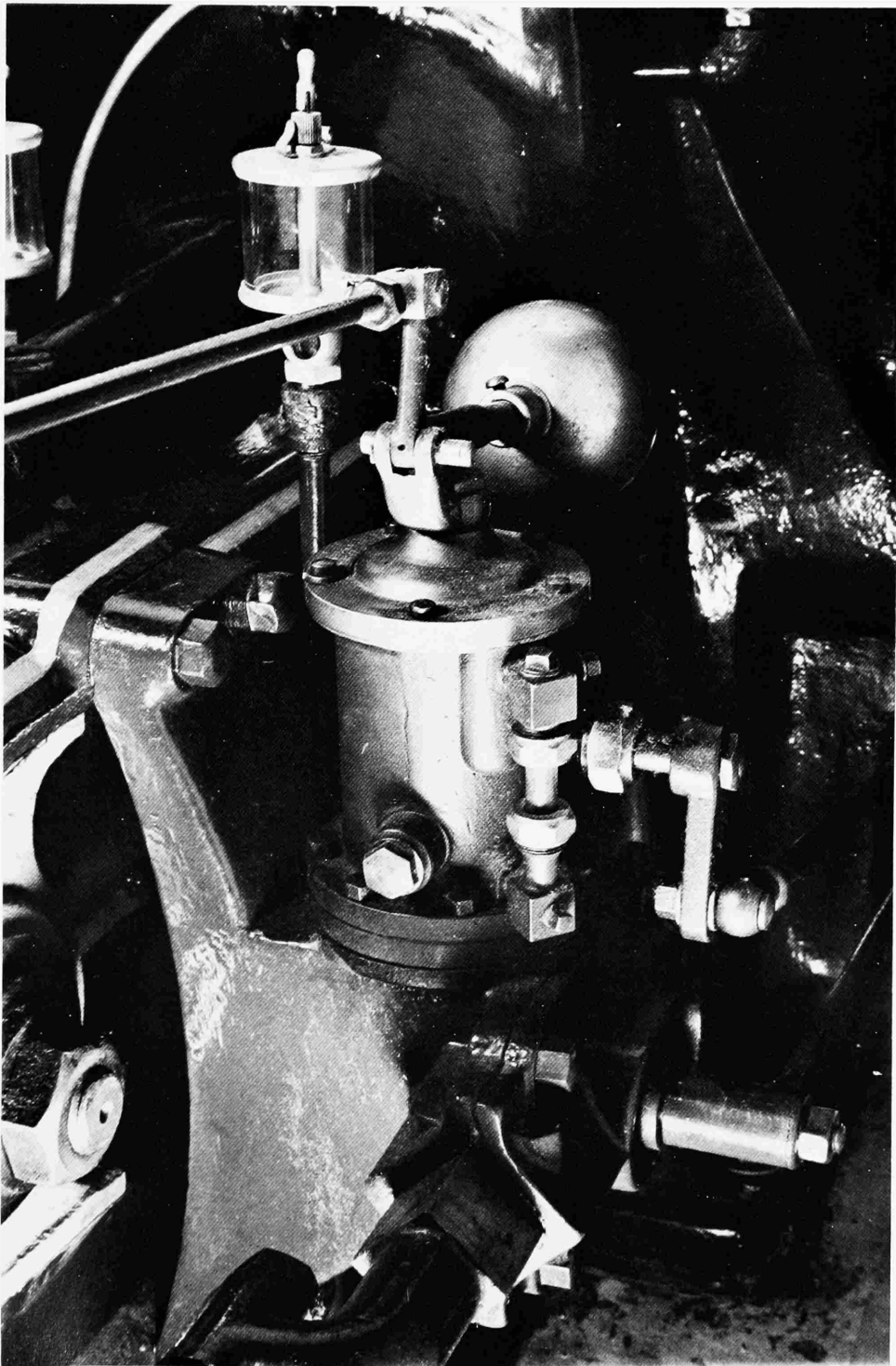

FIGURE 23.—Hydraulic governor by the "Mason Regulator Co." installed on a steam driven Frick refrigerator compressor. (NMHT 319243. Photo CLG.)

the velocity of the oil. The vane is connected to the valve gear of the steam engine by suitable linkages.

A similar hydraulic governor (Figure 23), although not a patent model, is that of the Mason Regulator Co. installed on the steam-driven "Frick" refrigeration compressor of 1898 (NMHT 319243; Accession 236002; the governor is marked "MASON REGULATOR CO. BOSTON, MASS. U.S.A. PAT. MAR. 27, 1883. FEB. 10, '85"; size without linkages $4\frac{1}{2}$ " diam. \times 6" high). It consists of an oiltight cylinder containing a piston pump, which is driven from the eccentric of the steam engine and discharges into a closed space under a diaphragm. The output oil pressure of the pump, as a measure of engine speed, displaces the weight- and spring-loaded diaphragm, causing a motion that is transmitted to the throttle valve by mechanical connections.

Other governors of this type were manufactured, for example, by Stillman B. Allen of Boston (originally the "Huntoon" governor), by J. B. Duff of New York, and by Jenkins & Lee of Philadelphia. They all had one serious disadvantage. Not only did these governors consume power, but they also converted the lost energy into heat which changed the oil viscosity and thus impaired their accuracy. In 1919, therefore, W. Trinks in his textbook on governors classified this type of governor as "discarded."²⁶

The patent model of William Yates, 1876, represents a conventional governor (Figure 24) with its belt drive (NMHT 321888; Accession 245986; U.S. Patent 174888 of 14 March 1876; brass on wood base, $11''\times 5''\times 9''$; unmarked). The invention patented here is only an external accessory to the governor, a belt-idler operated valve-stop. Most governors were driven by leather belts. If the belt slipped off or broke, the governor would stop, opening the steam valve wide and causing the engine to race at uncontrolled high speed. The safety device described here eliminates this danger. An idler pulley running

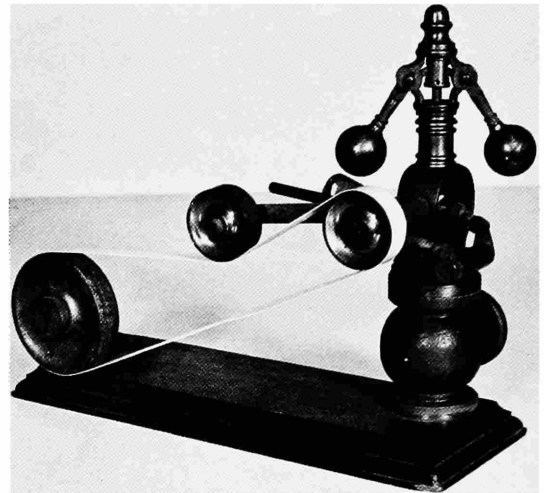

FIGURE 24.—Patent model of William Yates of a steam engine governor with a belt-idler operated valve-stop, 1876. (NMHT 321888. Photo CLG.)

on the belt is connected with a triggering mechanism in the valve stem. If the belt slips off or breaks, the idler drops, disengaging the valve stem from the governor. Under the effect of a counterweight (the horizontal bar above the valve body; the weight itself has been lost) the throttle valve is promptly closed. A further advantage of the invention

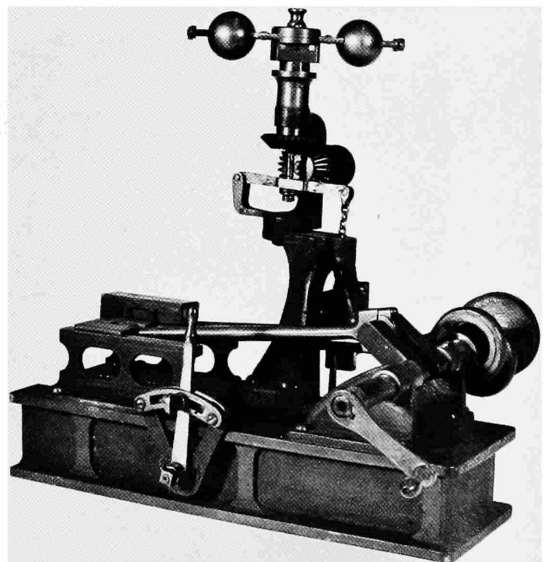

FIGURE 25.—Patent model of steam engine governor by John Knowlson, 1876. (NMHT 325615. Photo CLG.)

26. Willibald Trinks, *Governors and the Governing of Prime Movers* (New York, 1919), p. 144.

is claimed that it also serves as a belt tightener.

The patent model of John Knowlson, 1876 (NMHT 325615; Accession 249602; cast iron and brass, $11\frac{3}{4}'' \times 10\frac{1}{4}'' \times 11\frac{1}{2}''$; marked "J. KNOWLSON. TROY. N.Y."), represents two separate patents, one on valve gear (U.S. Patent 176141 of 18

April 1876), the other on steam engine governors (U.S. Patent 177404 of 16 May 1876). The model (Figure 25) shows governor, valve gear, crankshaft, and crosshead of a positive-cutoff steam engine, where the point of cutoff is changed by a sliding link controlled by the governor, similar to the Porter-Allen engine. The centrifugal governor consists of

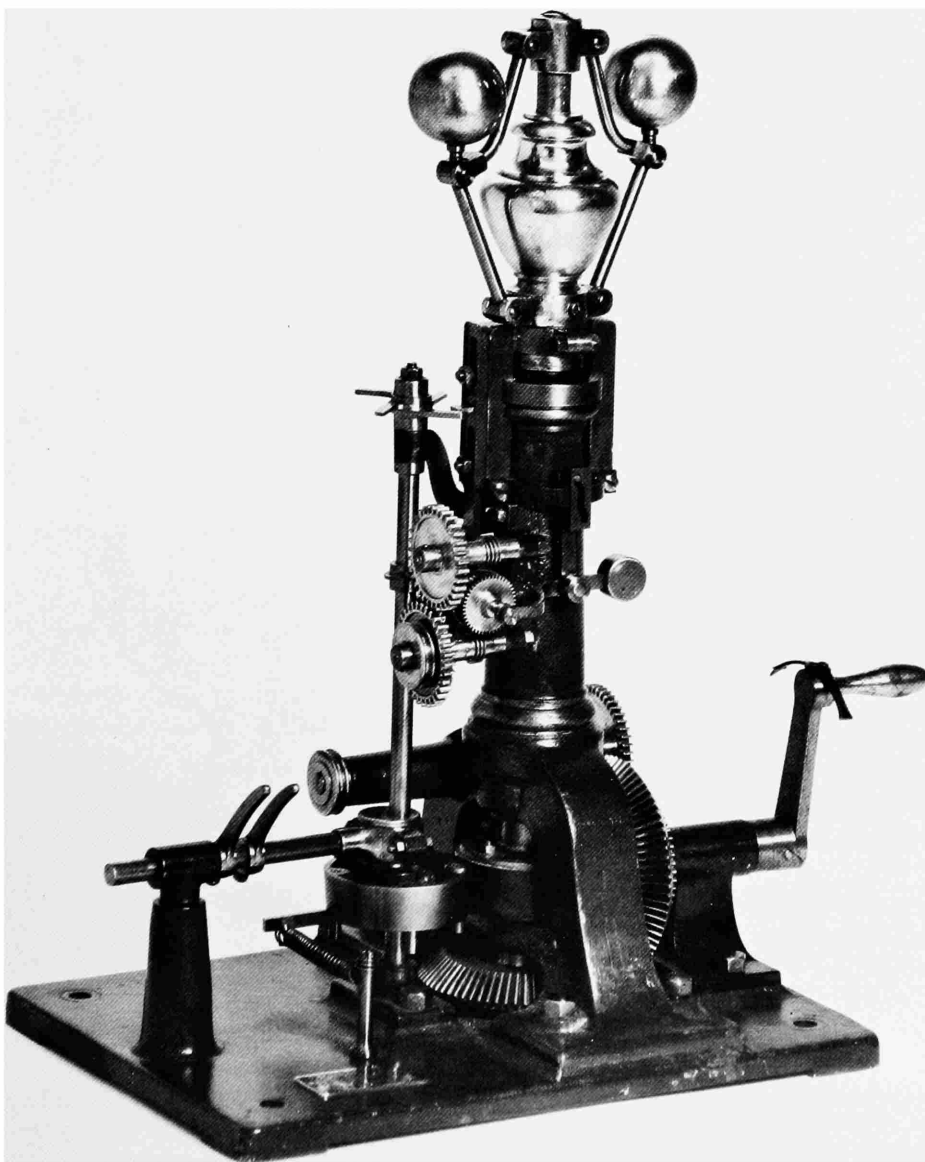

FIGURE 26.—Patent model of engine governor by Johann Georg Bodemer, 1876. (NMHT 309243. Smithsonian photo 69389.)

two weights sliding radially on horizontal bars, acting on the sliding link by chains passing through the hollow governor shaft. The centrifugal force on the flyweights is balanced by a leaf spring connected to the lower end of the chain, although the patent specification also mentions the possibility of simple counterpoises. The advantages claimed for this governor are "simplicity in operation, durability for continued work, and efficiency in action under all circumstances," especially with cutoff engines, claims that were not confirmed by commercial success.

The exquisitely made patent model of J. G. Bodemer, 1876 (NMHT 309243; Accession 89798; U.S. Patent 176591 of 24 April 1876; steel and brass, $10\frac{1}{2}'' \times 6'' \times 12''$; marked "Modell von Bock & Handrick Dresden 550"), displays a prodigious, although perhaps impractical, amount of mechanical ingenuity (Figure 26).²⁷ Designed as a governor for hydraulic turbines, its output device is a belt shifter controlling the motion of the turbine valve driven by an independent source of power. It consists of a conventional loaded governor acting upon the belt shifter through two separate control mechanisms, of which the more sensitive one can be superimposed optionally upon the basic mechanism. Each is actuated by a pin riding in an S-shaped slotted cam attached to the slide of the governor, determining which one of three possible positions—forward, neutral, or reverse—the belt shifter will occupy. The power required to move the belt shifter is supplied directly from the mainshaft of the governor, through a complicated friction drive set in motion according to the governor output.

A governor of this design was shown at the Centennial Exhibition at Philadelphia in 1876. A simplified version of Bodemer's governor was used to regulate the turbines of the inventor's own plant.²⁸ Johann Georg Bodemer (1842–1916), son of a wealthy textile manufacturer in Zschopau, Saxony, in-

centidentally, was married to a daughter of Donald McKay, the well-known New England ship builder.²⁹

Despite its exotic appearance, the gyroscopic governor (Figure 27) of Joseph Reid, 1879, serves the same purpose as the common centrifugal governor (NMHT 309242; Accession 89797; U.S. Patent 220867 of 21 October 1879; steel with brass gears; $7\frac{1}{4}'' \times 5'' \times 12''$; marked "JOSEPH REID MONROE LA.")³⁰ As a speed-sensing device it employs a gyroscope geared to perform two separate simultaneous motions, rotation and precession, both proportional to engine speed. The gyroscope's axis of rotation is in-

29. *Neue Deutsche Biographie*, under "Bodemer, Johann Georg."

30. Taylor, *Catalogue of Mechanical Collections*, p. 85.

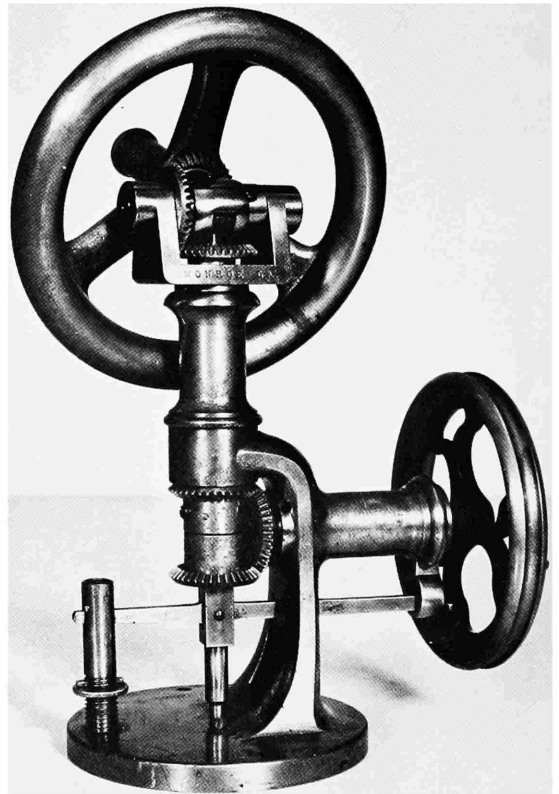

FIGURE 27.—Patent model of gyroscopic engine governor by Joseph Reid, 1879. (NMHT 309242. Photo CLG.)

27. Taylor, *Catalogue of Mechanical Collections*, p. 84.

28. *Dingler's Polytechnisches Journal* 222 (1876):505–524, pl. 11.

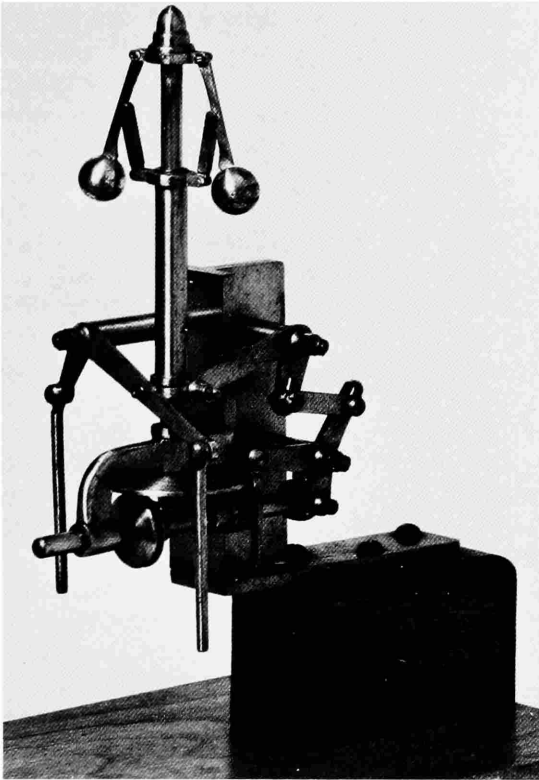

FIGURE 28.—Patent model of steam engine governor by George H. Corliss, 1882. (NMHT 308715. Smithsonian photo 69393.)

clined from the vertical axis of rotation; it is pivoted freely but held down by spring force. With increasing speed the gyroscope's axis tends to rise toward the vertical; the resulting motion is transmitted by suitable linkages to a horizontal lever, which is to be connected to the control valve. The patent includes a stop motion for the case of a breaking drive pulley. The particular advantage claimed for the gyroscopic governor is sensitivity to changes of speed.

George Corliss's diminutive patent model of 1882, a governor for steam engines (Figure 28), represents one of the last of his many inventions (NMHT 308715; Accession 89797; U.S. Patent 262209 of 8 August 1882; steel and brass on wood base; size of the governor proper $3'' \times 2'' \times 5\frac{1}{2}''$; un-

marked).³¹ The governor is driven by a friction drive: a friction roller connected with the engine and capable of axial motion runs perpendicularly against a disc at the bottom of the governor shaft. The governor slide is connected not only to the control valve, but also, through appropriate linkages, to the axle of the friction roller. When the flyballs rise, due to increasing speed, the friction roller is moved toward the center of the friction disc, driving the governor at a higher gear ratio, hence increasing the control response that results from a given speed deviation. The effect of the mechanism is then nothing more than to increase the proportional sensitivity of a conventional governor, a feat that could have been accomplished by much simpler means. The device had no known influence on further developments.

Valve-Mounted Governors

In the last third of the nineteenth century two standard types of governor were established which endured as long as steam engines were used: the first was a simple pulley-driven centrifugal governor mounted directly on a throttle valve; it was applied mainly on the numerous small steam engines which did not justify costly and elaborate automatic cutoff gear. Steam engines of larger size, in contrast, were the domain of shaft governors that were always combined with automatic cutoff. The valve-mounted governors were produced in large quantities at low prices by companies specializing in this field. The basic designs were adopted in the 1860s or 1870s, and were, with few changes, retained until the end of the steam engine era.

An early example of this type is the Judson governor, still employing the traditional centrifugal pendulum with heavy flyballs, designed for low engine speeds. From 1850 on, Junius Judson and his associate William A. Cogswell took out numerous patents for ac-

31. *Ibid.*, pp. 78-79.

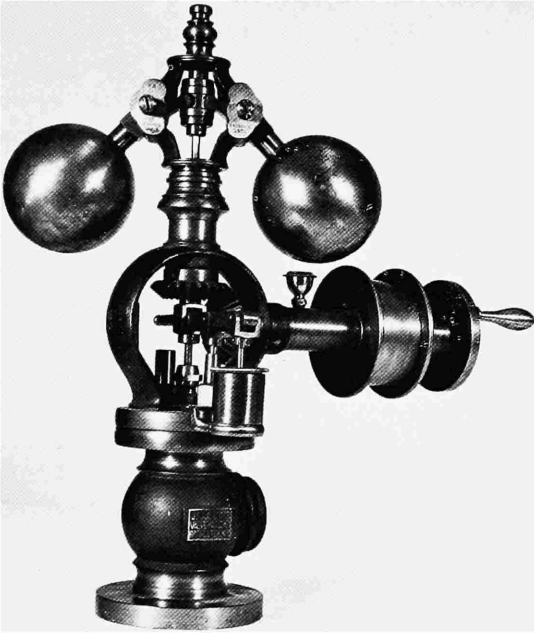

FIGURE 29.—Patent model of steam engine governor by Junius Judson and William A. Cogswell, 1875. (NMHT 309244. Photo CLG.)

cessories to their basic governor, one of which is represented by the patent model of 1875 (NMHT 309244; Accession 89797; U.S. Patent 169815 of 9 November 1875; marked "Judson Patent'd Dec. 5, 1871" and "120 Rev's"; mounted on $1\frac{1}{4}$ " valve; overall height 19").³² The patent model (Figure 29) consists of a governor from the actual production line to which an elastic clutch was added in the drive shaft as the patented feature. In order to prevent irregularities in the running of the engine from being transmitted to the governor, the belt pulley is mounted elastically on the drive shaft by means of a spiral spring concealed in the interior of the shaft.

A Judson governor installed in operating position on an actual engine is exhibited (Figure 30) on the J. I. Case portable steam engine of 1869 (NMHT 62A10; Accession 246139; governor mounted on $1\frac{1}{2}$ " valve). The governor is equipped with a dashpot and with an arrangement for changing the

controlled speed by suspending weights of different sizes from a lever which acts on the governor spindle. The dashpot, in general, is an inelegant but sometimes unavoidable expedient for quieting down engines with an inclination toward instability.

Another Judson governor, of the simplest type, and showing considerable wear, dates probably from the same period (NMHT 318460; Accession 234834).

The stationary steam engine built in 1864 by the United States Military Railroad Department, Alexandria, Virginia, is equipped with a large unidentified governor (Figure 31) closely resembling Judson's design (NMHT 310241; Accession 113602; unmarked; governor on 4" throttle valve; overall height 38"). Attached to it is a spring device for varying speed.

A similar valve-mounted governor, of diminutive size but operational, is displayed on the Jerrehian toy steam engine of about 1870 (NMHT 325908; Accession 258277).

Also into the Judson class belongs the simple valve-mounted governor on the rotary steam engine built by Henry J. Hendey in about 1870 (NMHT 314511; Accession 203480).

Far more progressive than the Judson governor was the spring governor invented in 1862 by Thomas R. Pickering (U.S. Patent 36621 of 7 October 1862). Here the traditional pendulum is replaced by three centrifugal weights on vertical leaf springs parallel to the axis of the governor, an arrangement that has become characteristic for Pickering governors. These springs made the governor independent of gravity effects and hence of the vertical position. Combined with flyballs of reduced size, the springs enabled the governor to function at high speeds. In a design of unrivaled simplicity, avoiding all pivots and moving linkages, the Pickering governor was highly accurate and almost indestructible. It has been used in a wide range of applications, from steam turbines to chronometric regulators, and it is still being manufactured.

The Museum possesses two specimens of early Pickering governors. The older one is

32. *Ibid.*, pp. 83–84.

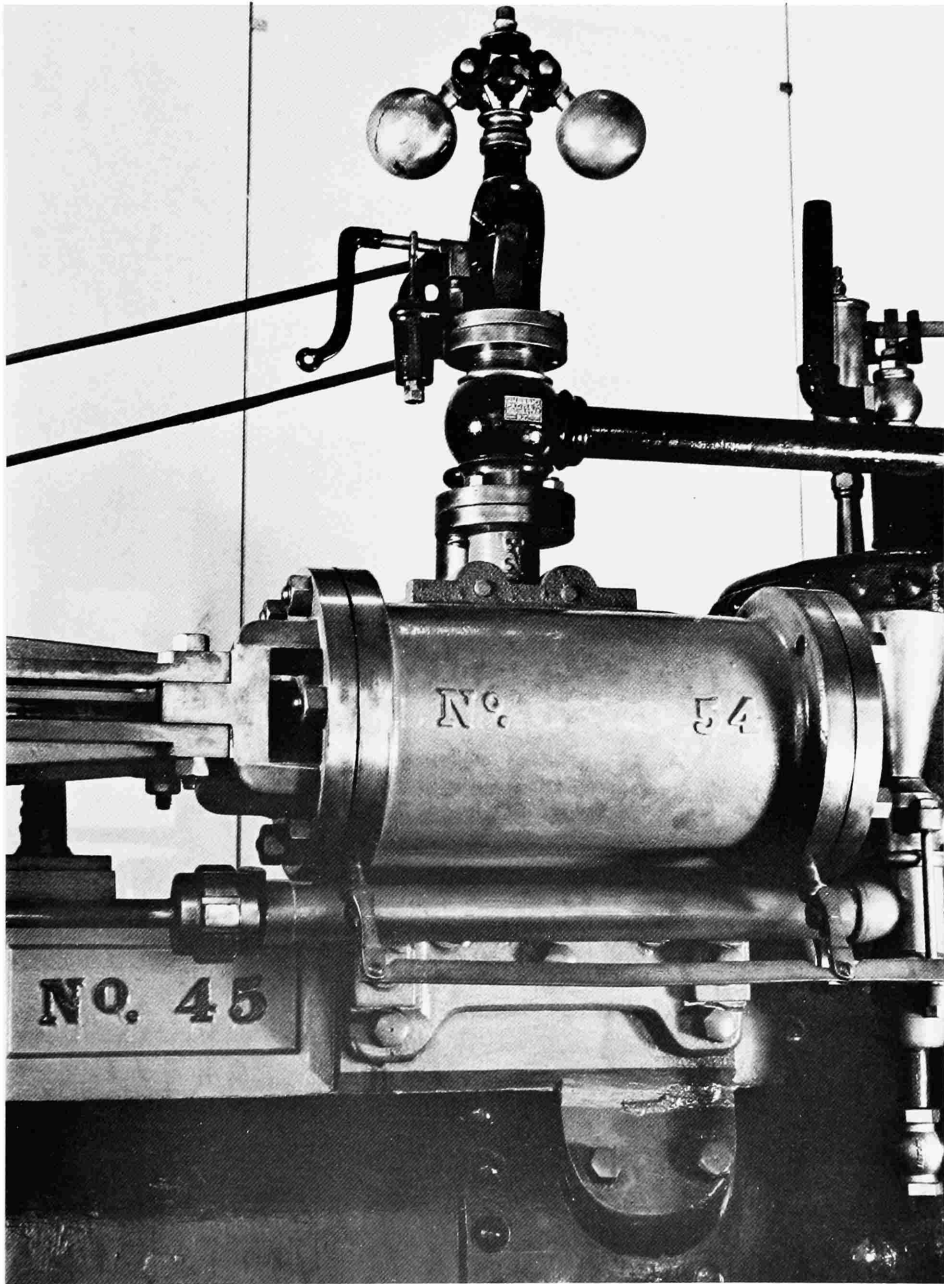

FIGURE 30.—Judson governor installed on the J. I. Case portable steam engine of 1869. (NMHT 62A10. Photo CLG.)

installed on an Otis steam elevator machine of 1875 (NMHT 318170; Accession 232978; marked, partly illegibly, "No. 3938; 360 REV."; mounted on 2½" valve). Very similar to it is a unit (Figure 32) dating probably from the 1880s (NMHT 310289; Accession

115810; marked "THE PICKERING GOVERNOR PORTLAND. CONN. U.S.A. SHAFT REV. 380"; serial no. 535798; mounted on a 2" valve, overall height 27").

Contrasted by these is a Pickering governor of 1931 (NMHT 310290; Accession 115810;

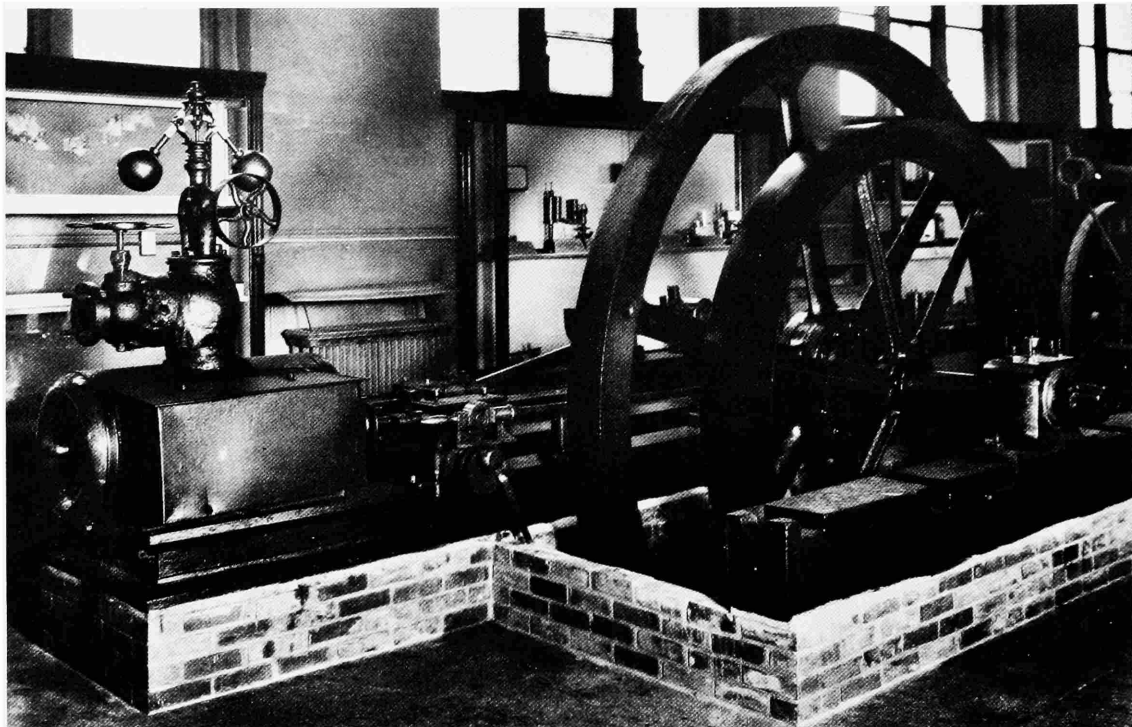

FIGURE 31.—Stationary steam engine built by the United States Military Railroad Department, 1864, shown at its former location in the Arts and Industries Building. (NMHT 310241. Smithsonian photo 31026.)

marked "MADE BY PICKERING GOV'R CO, PORTLAND, CONN. U.S.A. SHAFT REV. 600"; serial no. 535755B; mounted on 2" valve, overall height 30").³³ While the basic design conception is the same, the outward appearance (Figure 33) is drastically changed by a bell-shaped protective hood over the rotating parts of the governor. It is equipped with a "Ball Ranger" speed changer which adjusts the initial spring force on the governor, making the desired speed widely adjustable above and below the nominal 600 revolutions per minute.

The design of the Waters Governor Company of Boston, one of Pickering's competitors, is represented by a specimen (Figure 34) dating presumably from the 1880s (NMHT 325525; Accession 258280; unmarked; mounted on a 1" valve, of which the body has been lost; overall height 17").

It employs two centrifugal weights restrained each by a C-shaped leaf spring so as to permit only radial motion (U.S. Patent 110703 of Charles Waters, 3 January 1871). A provision for speed adjustment was standard equipment, while the stop motion for belt failure was optional.

An unmarked governor that also appears to be a Waters product is installed on the Baxter combination steam engine and boiler of 1868 (NMHT 325905; Accession 257094), to which it was added at an unknown later date.

A similar Waters governor is installed on a Frick "Eclipse" portable steam engine, built in 1877 (NMHT 58A9; Accession 222811; name plate partly illegible "Waters Pat. . . .1871 Boston, Mass."; governor mounted on 1½" valve).

Another manufacturer specializing in governors since the 1860s was the Gardner Governor Co. of Quincy, Illinois. The Gardner

33. *Ibid.*, p. 86.

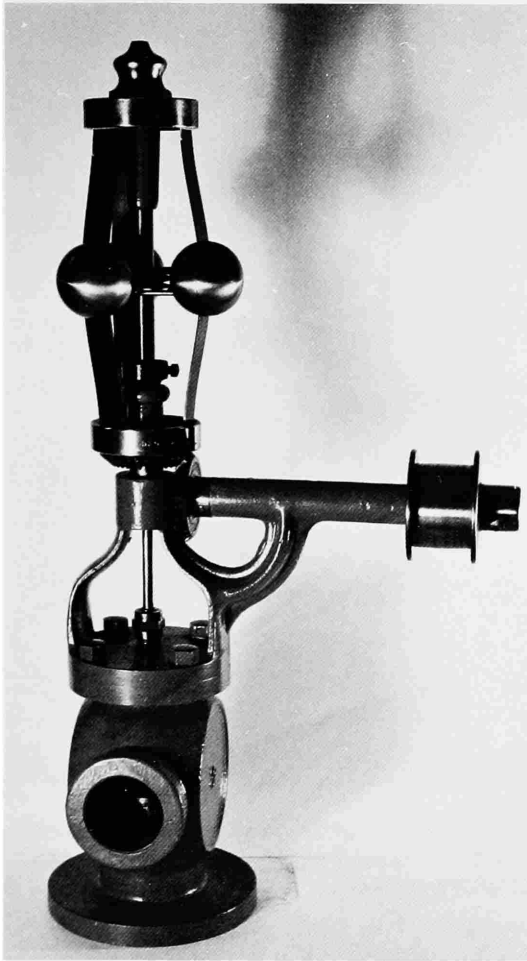

FIGURE 32.—Pickering steam engine governor, 1880s.
(NMHT 310289. Photo CLG.)

spring governor (Figure 35) in the Museum's collection was probably built in the 1930s (NMHT 329758; Accession 228958; mounted on $\frac{3}{4}$ " valve; overall height 14"; marked " $\frac{3}{4}$ GARDNER GOV. CO. QUINCY ILL. 339730: 600 REV."). It is typical for a high-speed steam engine governor of mature design. Two flyweights mounted at the end of leaf springs are arranged parallel to the axis; their centrifugal motion is transmitted to the stem of the steam valve by a conventional set of linkages. Provisions are made both for changing the controlled speed—even while the engine is running—and for automatically closing the valve in case of belt failure.

A special-purpose regulator derived from a

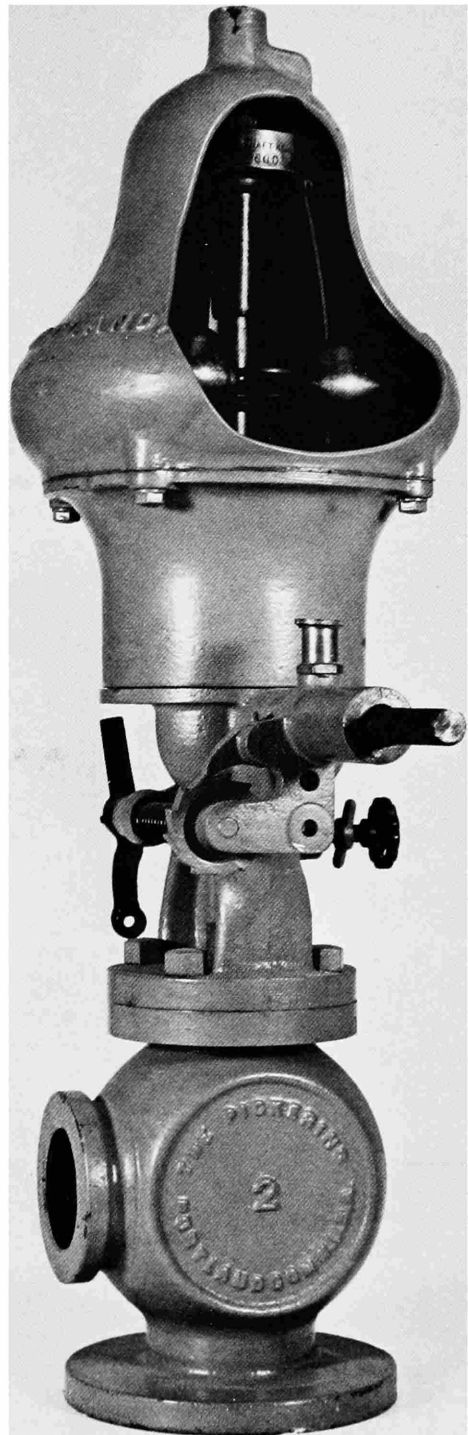

FIGURE 33.—Pickering steam engine governor, 1931.
(NMHT 310290. Photo CLG.)

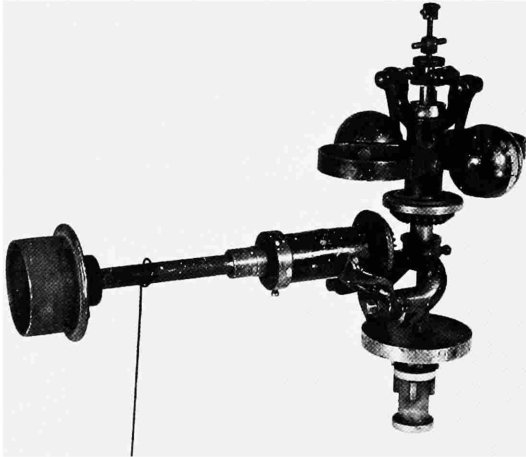

FIGURE 34.—Waters steam engine governor, 1880s. (NMHT 325525. Photo CLG.)

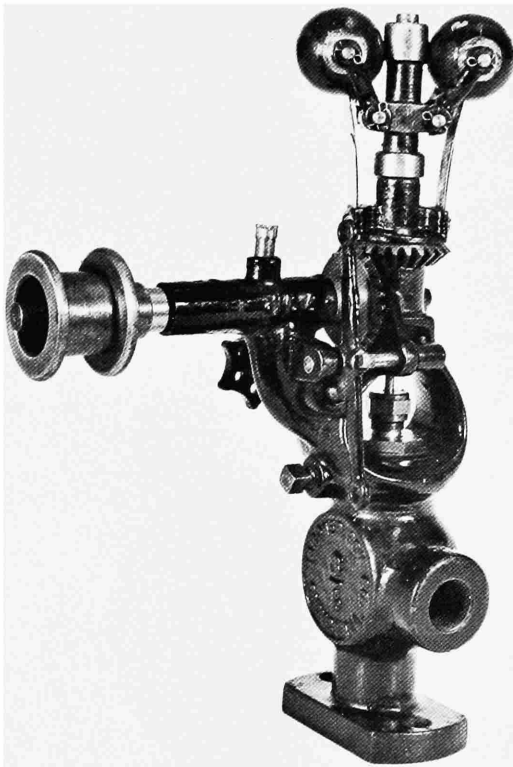

FIGURE 35.—Gardner steam engine governor, 1930s. (NMHT 329758. Photo CLG.)

conventional steam engine governor is the "Erie" compressor governor (Figure 36) built by the Jarecki Manufacturing Company about 1910–1920 (NMHT 326536; Ac-

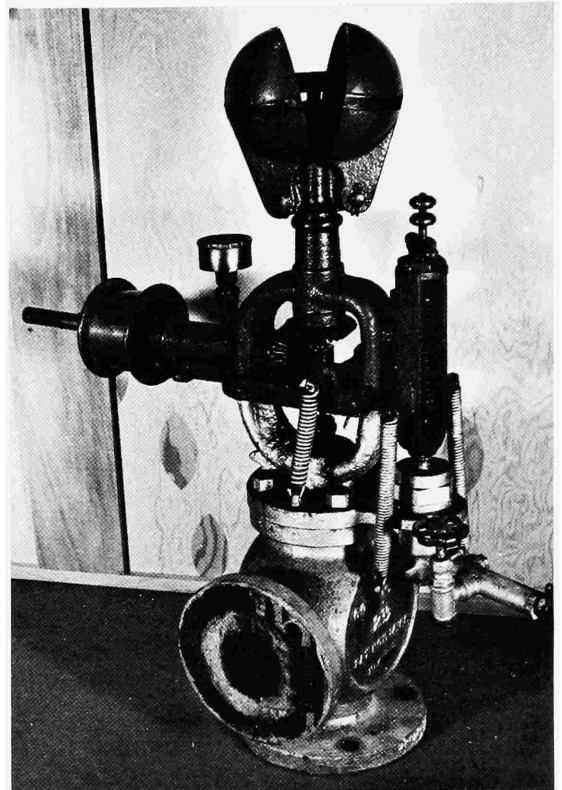

FIGURE 36.—Governor for steam-driven air compressor built by the Jarecki Mfg. Co., about 1920. (NMHT 326536. Photo CLG.)

cession 262282; mounted on a 2½" valve; overall height 29"; marked "JARECKI MFG. CO. ERIE PA. ½ ERIE GOVERNOR 275 REV. NO. [illegible], PAT. NOV. 14 '99, DEC. 25 1900, NOV. 25 1901, NOV. 22 1904, MAY 22, 1906"). Its purpose is to hold the output pressure of a steam-driven air compressor constant, while causing the steam engine to run at the lowest possible speed. Two flyweights, shaped as hemispheres, form a single 5-inch diameter sphere when the governor is at rest, separating at higher speeds. Their centrifugal force is balanced by a coil spring located outside of the governor body. As an unusual feature the governor contains a pressure-sensing device piped directly to the compressor output, generating a force on the valve stem in the same manner and direction as the centrifugal force of the flyweights. If the compressor output pressure rises above the desired value, the governor

responds by reducing the steam supply of the driving engine, and hence the compressor speed. The governor is equipped with an automatic safety stop of which the idler arm has been lost.

Although not valve mounted, a governor best listed at this point is that of the Willans central-piston compound engine of 1905 (NMHT 328723; Accession 275434; the engine is directly connected to a 240 V, 100 amp. D.C. generator, speed 470 r.p.m.). A centrifugal spring governor is mounted under a protective shroud directly on the crankshaft. It is connected by a long vertical rod to the throttle valve in the steam inlet line. Throttling control on a high-performance engine such as this could be justified only if the engine operated rather constantly near full load.

Shaft Governors

First patented in 1839 by Jacob D. Custer of Norristown, Pennsylvania (U.S. Patent 1179 of 21 June 1839), the shaft governor became popular in America in the 1870s, and a little later also in Europe where it was always regarded as a specifically American invention. In contrast to the cheap and simple valve-mounted governor, the shaft governor was an ingenious and complicated mechanism that had to be designed as an integral part of the individual steam engine. Its advantages were accuracy and economy of operation.

Shaft governors were used exclusively with automatic cutoff control. The older of the two forms of such control, that by detachable cutoff gear, employed for example by George H. Corliss, was limited to low engine speeds. Operation at higher speeds required positive cutoff, where the inlet valve gear was linked positively to the eccentric during the whole engine cycle. Various such mechanisms were invented that were based on the conventional flyball governor, the best known was the Porter-Allen arrangement. The same task, however, could be accomplished far more simply by the shaft governor. Located within

the flywheel, the basic centrifugal shaft governor employs several—usually two—centrifugal weights arranged symmetrically and balanced by springs. The weights are linked with the eccentric in such a way that when they move outward due to increasing speed, the throw of the eccentric is reduced causing earlier cutoff and hence a return to equilibrium speed.³⁴

Many shaft governors are based on the combined action of centrifugal force and inertia. The control response is proportional not only to the speed, as measured in terms of centrifugal force on the flyweights, but also to the rate of change of speed. This is accomplished by mounting the weights so that they will travel, relative to the flywheel, not on a purely radial path but rather on a path lying somewhere between the radial and the tangential direction. If then, for example, the engine is suddenly accelerated, the flyweights by their inertia are thrown backward, with the same effect upon the speed-control system as though they were moved outward due to centrifugal force. An early American patent describing such a governor was that of H. N. Throop, 1857 (Figure 17), but the idea of an inertial governor in general had already been published by Werner and William Siemens in 1845. Governors based on the inertial effect alone are unsuited for speed control, because they lack a sensing element for the controlled variable, speed, and therefore do not form a closed feedback loop. Pure inertia governors tend to maintain indiscriminately the momentary speed, but they cannot be set to hold the speed constant at any particular value, nor are they able to respond to very slow changes in speed.³⁵ Shaft governors, however, that combine the inertial action with the conventional centrifugal action—i.e., that provide “proportional plus derivative control”—have been highly successful because of their responsiveness and accuracy.

One of the first industrially successful shaft governors (Figure 37), patented in 1870 by Daniel A. Woodbury of Rochester, N.Y., is

34. Trinks, *Governors*, pp. 61–76.

35. *Ibid.*, pp. 9–10, 139–140.



FIGURE 37.—Patent model of shaft governor by Daniel A. Woodbury, 1870. (NMHT 251290. Smithsonian photo 30362.)

represented in our Museum by the original patent model (NMHT 251290; Accession 48865; U.S. Patent 107746 of 27 September 1870; 12" diam. flywheel on 9"×12"×7" wood base).³⁶ Within the flywheel two weights are mounted at the ends of leaf springs in such a way that they are free to move in radial direction only. The governor then is purely centrifugal. The flyweights are connected by a pair of S-shaped links to a mechanism at the hub of the wheel which reduces the throw of the eccentric as the flyweights move outward, and vice versa.

Another centrifugal shaft governor (Figure 38) is the patent model of Joseph W. Thompson and Nathan Hunt of Salem, Ohio, 1878 (NMHT 308700; Accession 39797; U.S. Patent 204924 of 18 June 1878; steel flywheel 6" diam.; marked "BUCKEYE ENG. CO. SALEM, O.")³⁷ Two weights, mounted on parallel pivoted levers permitting only radial motion, are balanced by two coil

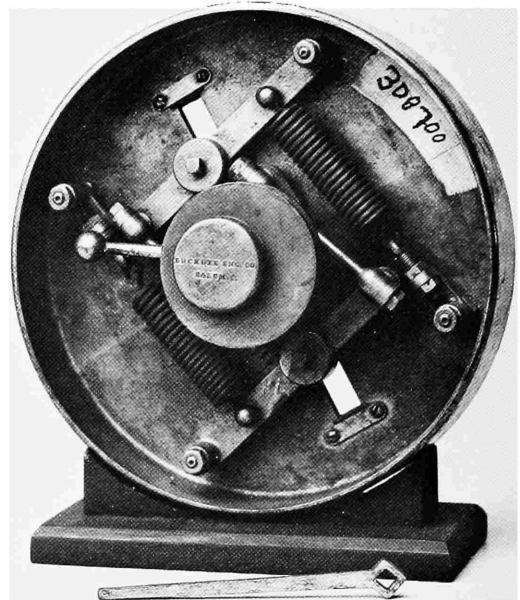

FIGURE 38.—Patent model of shaft governor by Joseph W. Thompson and Nathan Hunt, 1878. (NMHT 308700. Smithsonian photo 32595-A.)

springs. The weights are linked with the eccentric, adjusting not the throw but rather the lead angle of the eccentric with reference to the crankshaft, which equally results in a variation of the point of cutoff. The governor sensitivity and the desired speed can be adjusted by varying the spring tension and by changing the distance of the weights from the pivot point. The Thompson-Hunt shaft governor was usually combined with the famous "Buckeye" steam engine, a successful high-speed engine; it became one of the most popular constructions of shaft governors.

Simple centrifugal shaft governors are furthermore to be found on two small steam engines, both dating from the 1880s, namely the self-contained boiler-engine unit (Figures 79 and 80) built by the Shipman Engine Co. of Boston (NMHT 315712; Accession 221209), and the Boesch model (fully operational) of a high-speed engine (Figure 39) of the Harrisburg Foundry and Machine Co. (NMHT 325664; Accession 255732).

36. Taylor, *Catalogue of Mechanical Collections*, p. 83.

37. *Ibid.*, p. 85, pl. 19:2.

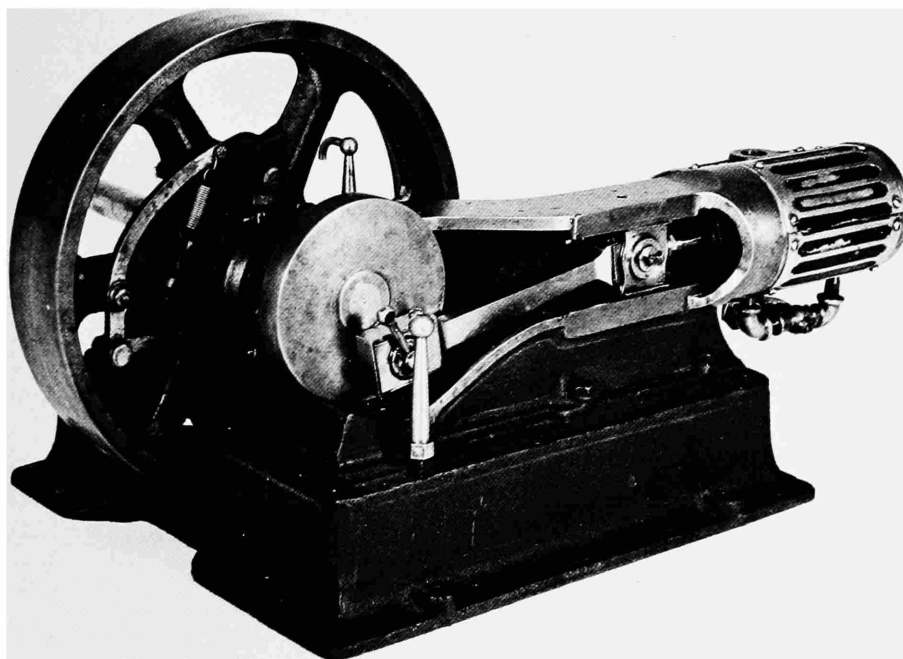

FIGURE 39.—Model of Harrisburg steam engine. (NMHT 325664. Photo CLG.)

A shaft governor actuated by inertia and centrifugal forces (Figure 40) is employed on the Westinghouse Automatic compound engine of 1896 (NMHT 322556; Accession 249412; engine no. 1015; 45 hp with 125 p.s.i. at 375 r.p.m.; flywheel 42" diam. \times 10 $\frac{1}{4}$ "). This single-acting, high-speed compound engine, invented by Henry Herman Westinghouse (1853–1933, brother of George Westinghouse) in 1888, was progressive in several ways. The engine is modern in appearance with its two cylinders housed in a single vertical block; it was of unprecedented economy, both in operation, due to combining the compound arrangement with high speed, and, by virtue of mass production, in initial cost.³⁸

The compactly designed shaft governor is contained in an oil-filled sealed compartment

at the hub of the flywheel. In an arrangement somewhat reminiscent of the Buckeye governor, two flyweights, counteracted by heavy helical springs, are linked with the eccentric to adjust its throw. The inertia effect is obtained simply by mounting the flyweights so that they can swing tangentially as well as radially.³⁹

The Westinghouse Junior Automatic, a simplified smaller version of this engine, built about 1900 (NMHT 309924; Accession 111907; serial no. 2909), is equipped with a shaft governor of similar but much simpler design, also employing both inertia and centrifugal force.⁴⁰

Also regulated by a centrifugal-inertia governor is a steam engine built by the Ball

38. Thurston, *Manual of Steam Engine*, II:393–394; Matschoss, *Entwicklung der Dampfmaschine*, II:214–218.

39. "The New Westinghouse Compound Engine Governor," *Iron Age* (2 July 1891):6–7.

40. Taylor, *Catalogue of Mechanical Collections*, p. 54, pl. 14:2.

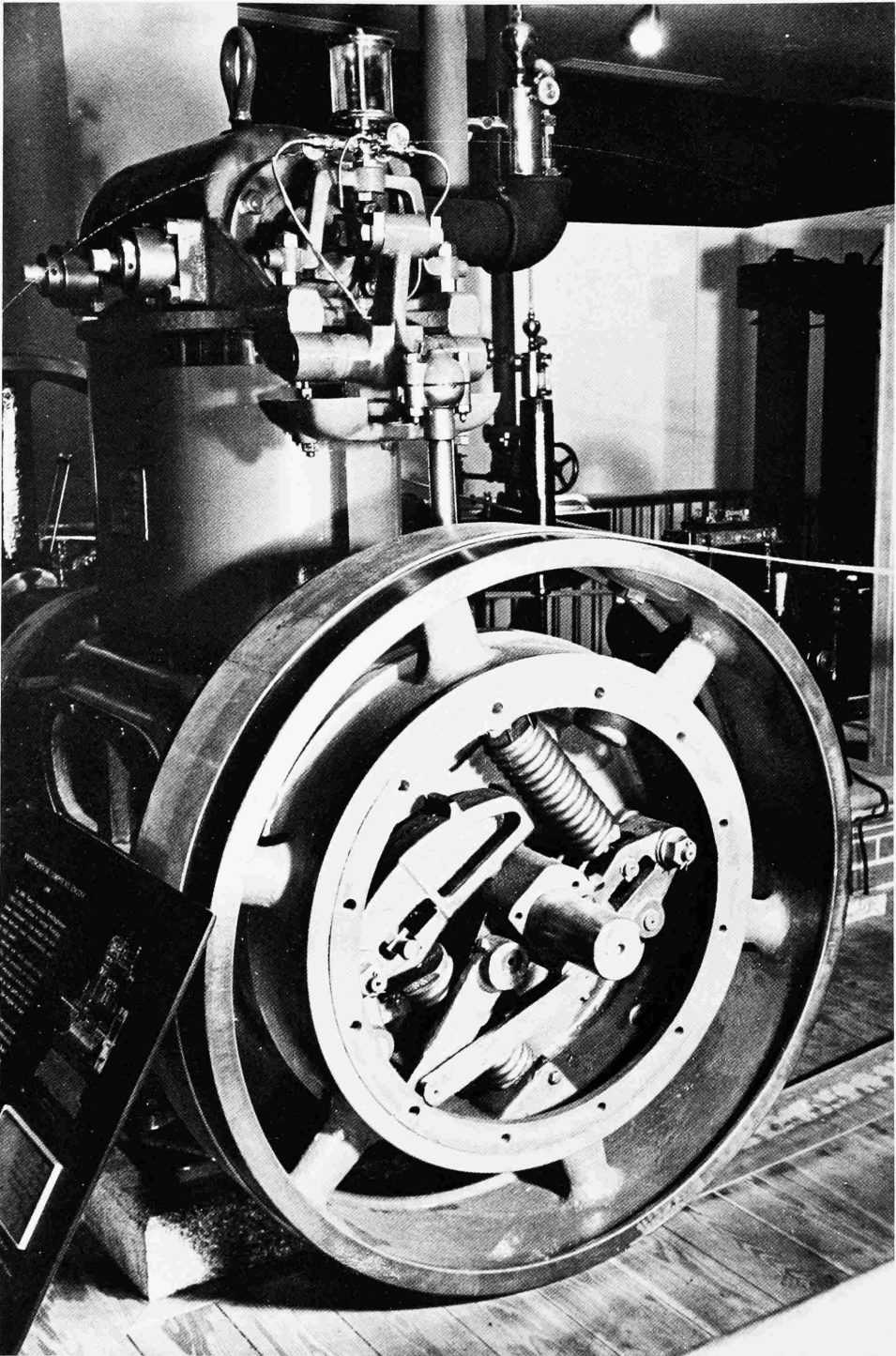

FIGURE 40.—Westinghouse "automatic" compound steam engine, 1896.
(NMHT 322556. Photo CLG.)

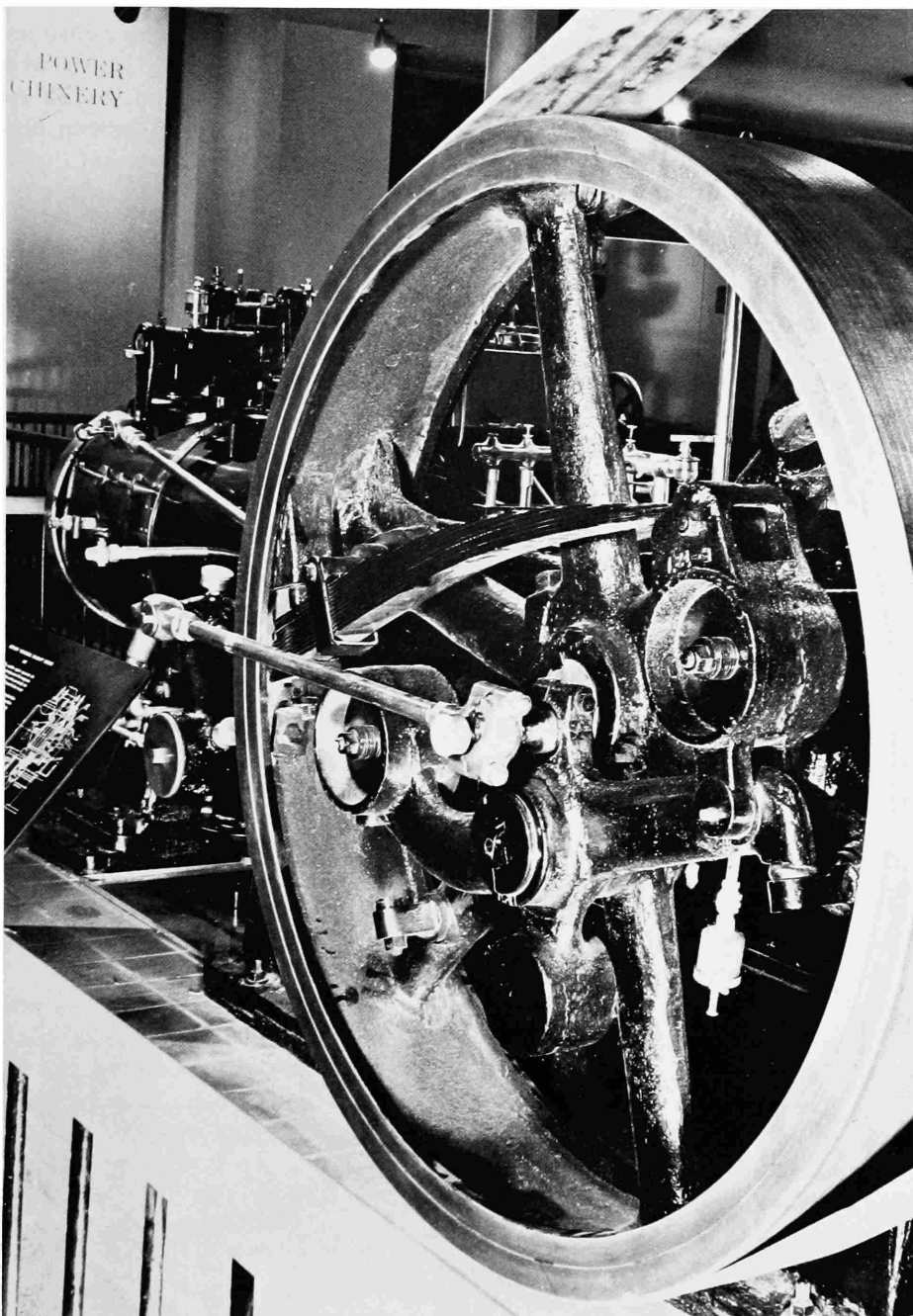

FIGURE 41.—Skinner "Universal Unaflow" steam engine, 1926. (NMHT 319477. Photo CLG.)

Engine Co. of Erie, Pa., in 1896 (NMHT 322557; Accession 249412; serial 3350; 40 KW at 300 r.p.m.). Its designer, Frank H. Ball, experimented with a variety of shaft

governors without arriving at a standard type. The present governor employs two flyweights, of which one responds to inertia effects and the other to changes of centrifugal

force, each balanced by helical springs. By means of suitable linkages the flyweights change the lead angle of the eccentric. A dashpot is installed to damp out oscillations of the flyweights.

The Museum's latest steam engine controlled by a shaft governor is the Skinner "Universal Unaflo" engine built in 1926 (NMHT 319477; Accession 237917; 25-75 hp with 150 p.s.i. at 250 r.p.m.; engine serial no. 10737; flywheel 62" diam. \times 11"). The Skinner inertia governor (Figure 41) is dis-

tinguished by its simplicity of construction. It has only three moving parts: a large swinging beam pivoted near its center on a spoke of the flywheel; a heavy spring fixed to the rim of the flywheel; and a link connecting both. The mass of the swinging beam is distributed in such a manner that it will respond to inertia forces far more strongly than to changes in centrifugal force. Since the eccentric is an integral part of the beam, any motion of the beam is equivalent of shifting the eccentric.

Speed Regulation of Other Prime Movers

Governors for Waterwheels and Turbines

The conditions of operation of a waterwheel governor are very different from those of the steam engine. On the steam engine the various mechanical control elements are well lubricated and of relatively light weight. The operating medium, steam, is elastic and of little inertia, responding to control actions instantly and without dangerous pressure surges. The conditions under which waterwheels operate are rather the opposite. The final control elements, restrictions in water passages, are massive and heavy, and so are the mechanisms actuating them upon signals from the governor. Water, being incompressible and heavy, responds to attempts to change its velocity with pressure changes which can be destructive. These differences are reflected in governor design. Practically all steam engine governors described here so far take the energy for moving the final control element directly from the centrifugal governor, that is, from the sensing element; they are therefore direct-acting governors. Waterwheel governors, on the other hand, are indirect-acting—or servo-powered: the energy for moving the control gates is provided by a source from outside of the governor.

MECHANICAL SERVO GOVERNORS.⁴¹—A representative of the class of purely mechanical

waterwheel governors is the Rodney Hunt governor (Figure 42) of about 1900 (NMHT 318011; Accession 228784; marked "DOUBLE ACTING REGULATOR NO. 2. MADE BY R. HUNT MCH CO. ORANGE MASS.": short-base design; size 32"×21"×34"). The governor is described exhaustively in United States Patent 307758 (11 November 1884) of Charles E. Gibbs, which covers some improvements over a conventional design known as the "Scholfield" governor, named after N. Scholfield who received United States patents on waterwheel governors on 17 November 1836 and 21 July 1857. Its principle of operation is: a shaft with two eccentrics set at 180° to each other is continuously rotated by the waterwheel. The eccentrics keep in constant motion two reciprocating arms, to the ends of each are attached two ratchet pawls, facing in opposite directions. The ratchet arms move along the circumference of two large ratchet wheels fixed on the shaft positioning the control gate. The centrifugal governor, through suitable mechanical connections, determines which one of the pawls will engage the ratchet wheels. If the actual speed is equal to the desired speed, both sets of pawls are held back. If the speed is too low, the pawls that face forward are brought into action, turning the ratchet wheels forward and thus opening the water gate, while in the opposite case the action is reversed. The innovations described in Gibbs' patent of 1884 are: a lever attached to the governor spindle with a sliding weight for varying the controlled speed; a friction brake on the output shaft to avoid backlash; and a limiting

41. Into this class belong also the patent models by H. A. Luttgens (1851), O. A. Kelley and E. Lamb (1865), and J. G. Bodemer (1876), see Figures 14, 19, 26.

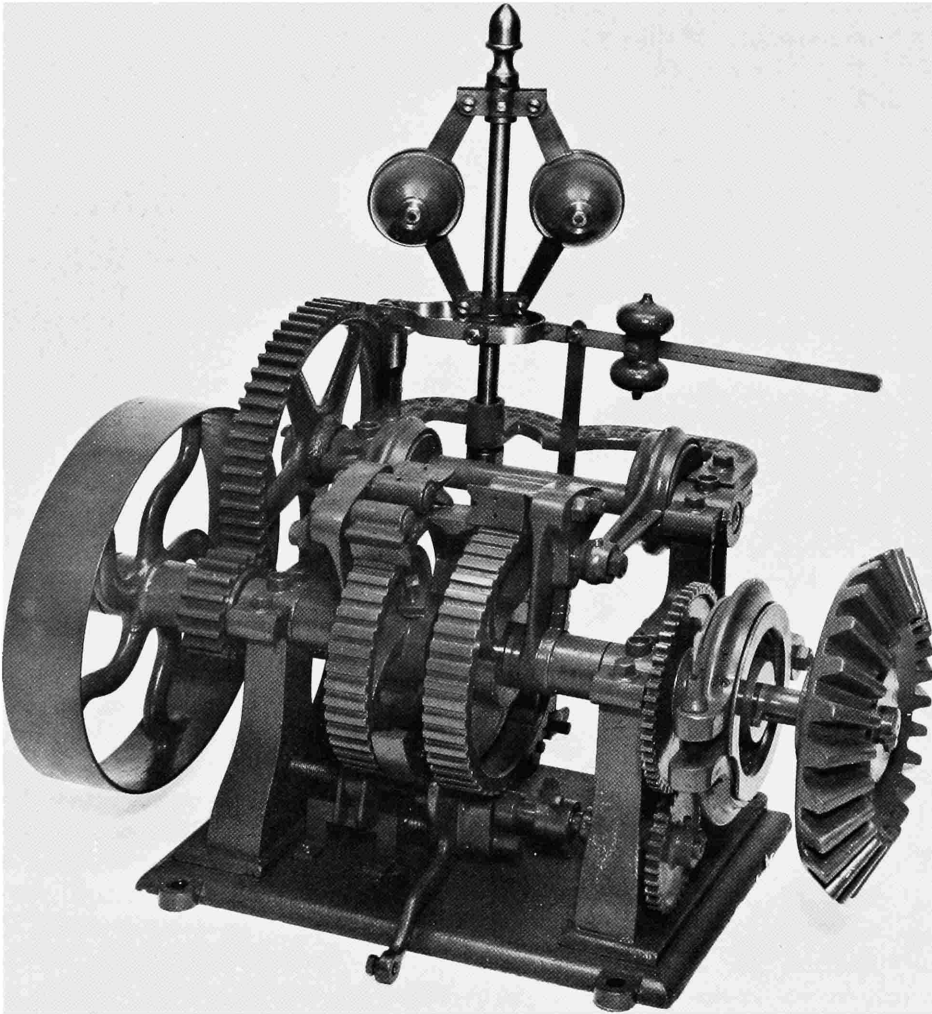

FIGURE 42.—Rodney Hunt water turbine governor, about 1900. (NMHT 318011. Smithsonian photo 72199.)

device which disengages the governor action when the gate reaches its fully open or closed position.

Other examples of mechanical servo governors are the earlier Woodward governors. The Woodward "Type 3" water turbine governor (Figure 43a) of 1903 (NMHT 315896; Accession 221844; serial no. 1309, used on a 50 hp, 23" Trump turbine), a modification of the basic invention of Amos Woodward (U.S. Patent 103813, 31 May 1870), is described in detail in the U.S. Patent 432105 of

Amos and Elmer E. Woodward of 15 July 1890. It functions as follows:

On the upright shaft are two friction pans a and b [Figure 43b]. These pans are loose on the shaft, the upper one being supported in position by a groove in the hub and the lower one by an adjustable step-bearing. Between these pans, and beveled to fit them, is a double-faced friction wheel c, which is keyed to the shaft. This shaft and friction wheel run continuously and have a slight endwise movement. They are supported by lugs on the ball arm and therefore rise and fall as the position of the balls varies with the speed.

When the speed is normal, the inner or friction

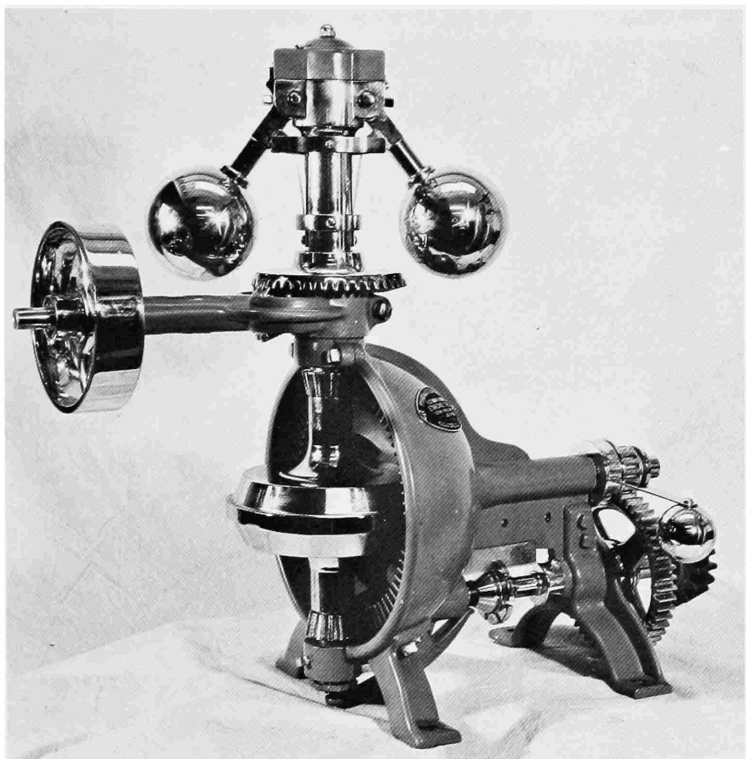
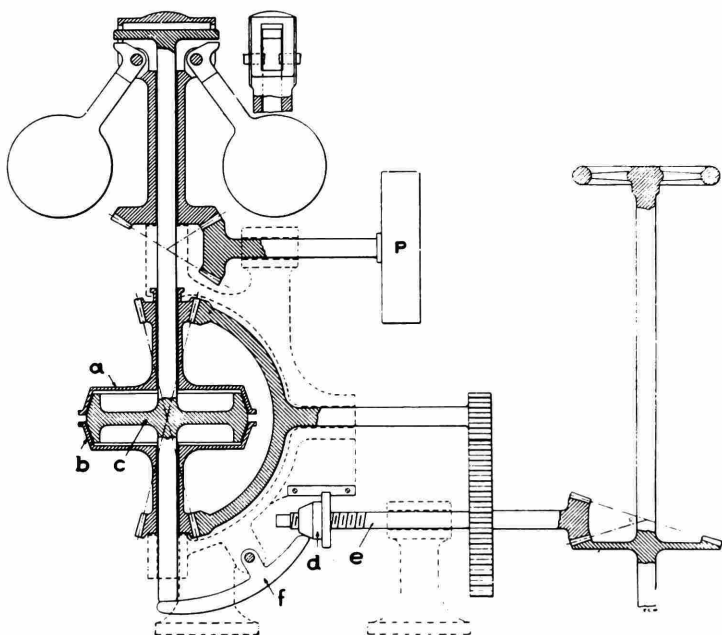

FIGURE 43a.—Woodward "Type 3" water turbine governor, 1903. (NMHT 315896, Smithsonian photo 45926-J.)

FIGURE 43b.—Sectional Drawing of Woodward "Type 3" mechanical waterwheel governor. Reprinted from Daniel W. Mead, *Water Power Engineering*, 2nd ed. (New York, 1915), fig. 288. Used with permission of McGraw-Hill Company.



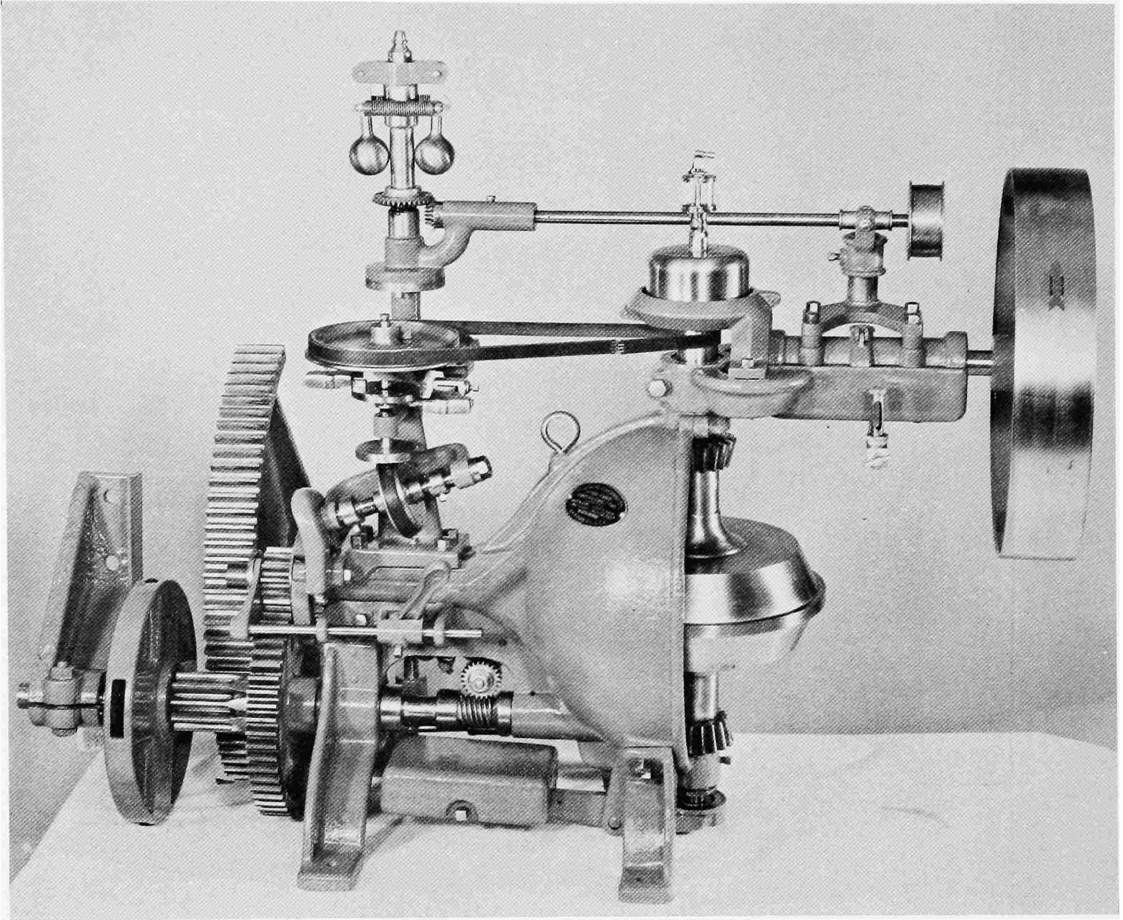

FIGURE 44.—Woodward "Model D" water turbine governor, about 1905–1910. (NMHT 320331. Photo Woodward Governor Co.)

wheel revolves freely between the two outer wheels or pans which remain stationary. When a change of speed occurs, the friction wheel is brought against the upper or lower pan as the speed is either slow or fast. This causes the latter to revolve and, by means of the bevel gears, turn the gates in the proper direction until the speed is again normal. As the gate opens the nut *d*, travels along the screw *e*, which is driven through gearing by the main governor shaft and as the gate reacts, the nut *d*, coming in contact with the lever *f*, throws the vertical shaft upward and the governor out of commission.⁴²

This governor, like the previously described Rodney Hunt governor, was well suited to serve in mills and factories where changes in load were neither frequent nor

rapid. But, employing only the "integral response"—its output is proportional to the time integral of the speed deviation—it had unfavorable dynamic characteristics; it was slow and prone to instability.

To correct these deficiencies, the Woodward Company developed their "compensating" governor, patented by Elmer E. Woodward in 1901 (U.S. Patent 679353, 30 July 1901). The Museum has a specimen of this type—a Model D (Figure 44)—built about 1905–1910 (NMHT 320331; Accession 243909; serial no. 2624; size 50"×20"×40"). It is directly derived from the basic Woodward governor described above; its distinction is a closed feedback loop within its own action, which converts the integral-response

42. Daniel W. Mead, *Water Power Engineering*, 2nd edition (New York, 1915), pp. 462–463.

governor into a proportional governor. This is done briefly as follows: On the integral-response governor, upon an error signal, a mechanism will be set off which moves the water gate at constant speed in the corrective direction until the actual and desired speeds are equal. On the "compensating" governor, another mechanism containing the characteristic "friction wheel compensator" is added to the effect that the corrective action limits itself in such a way that the output change will be directly proportional to the input deviation. Governors of this type can be adjusted for much higher sensitivity without a risk of instability.⁴³

HYDRAULIC SERVO GOVERNORS.—The hydraulic servomotor emerged as a rival to the mechanical servo relay. In the 1860s such devices had been used in automatic steering devices of ships,⁴⁴ but soon they were also employed on the governors of water turbines where large actuating forces were required. Inserted between the governor and the control valve, the servomotor has the function to relay the governor output signal to the final control element with the utmost fidelity, but greatly amplified in force. As the principle sketches (Figures 45 and 46) show, its model is obviously the steam engine, with the "pilot valve" corresponding to the valve gear, and the "power cylinder" to the working cylinder of a double-acting engine. The working medium is a high-pressure fluid, possibly steam, water, or air, more commonly oil, entering at the supply port between the two small pistons of the pilot valve. If the pilot valve is moved upward by the governor, the high-pressure fluid will act on the upper side of the power piston causing it to move downward, while the space below it is vented. Conversely, a downward motion of the pilot valve will result in an upward motion of the power piston.

Servomotors designed according to Figure 45, however, are quite unsatisfactory, for a

small governor action will lead to a complete opening or closing of the control valve, hence to a violent deceleration or acceleration of

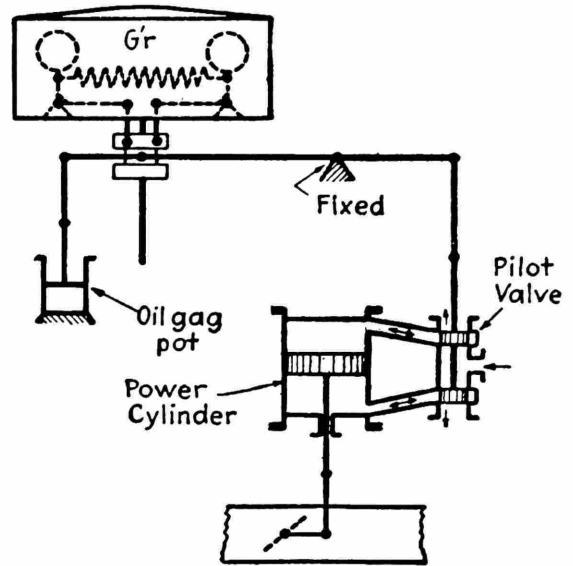

FIGURE 45.—Governor linked to hydraulic servomotor without feedback. This arrangement would tend to be unstable. Reprinted from W. Trinks, *Governors and the Governing of Prime Movers* (New York, 1919), p. 174, by permission of D. Van Nostrand Company.

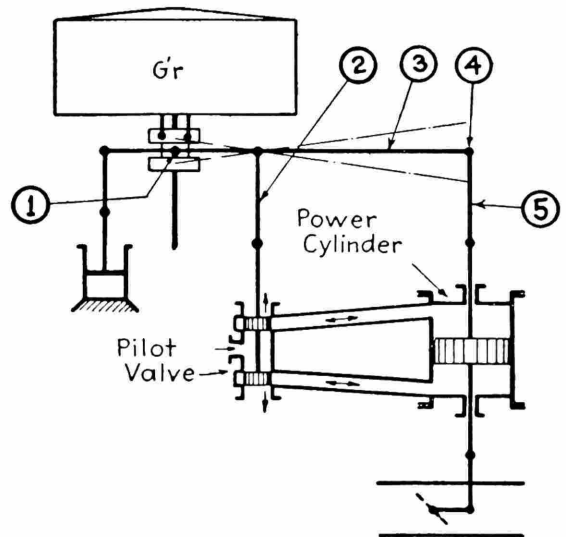

FIGURE 46.—Governor and hydraulic servomotor, stability by feedback linkage 3-4-5. Reprinted from W. Trinks, *Governors and the Governing of Prime Movers* (New York, 1919), p. 176, by permission of D. Van Nostrand Company.

43. *Ibid.*, pp. 463-466.

44. H. G. Conway, "Some Notes on the Origins of Mechanical Servo Mechanisms," *Transactions of the Newcomen Society* 29(1953-55):55-75.

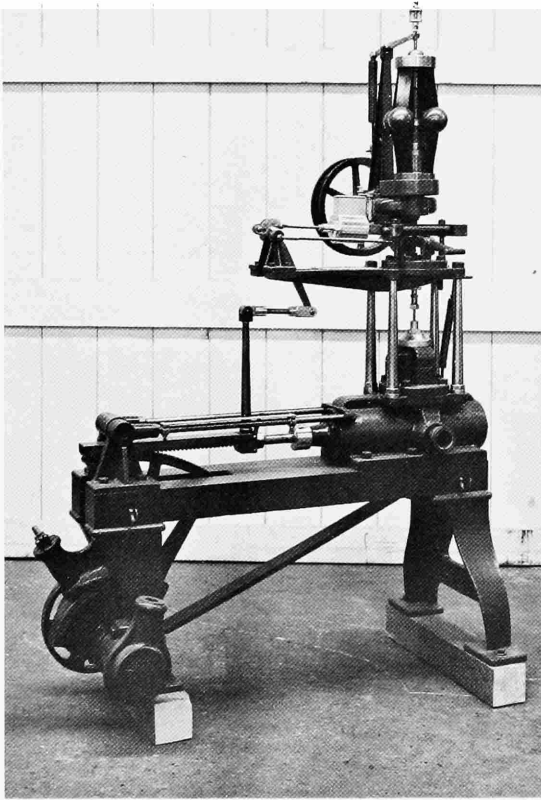

FIGURE 47.—Lombard "Type F" water turbine governor with hydraulic servomotor, 1912. (NMHT 320136. Smithsonian photo X2337.)

the machine, and finally to an increased governor action: in short, to instability. This is avoided by adding to the servomotor the expedient of feedback (see Figure 46). The lever connecting the governor with the pilot valve is extended to the rod of the power piston. This has the result that the motion of the power piston becomes proportional to that of the governor slide. The feedback lever, then, is equivalent to the compensating mechanism of the Woodward mechanical governors. Added to the feedback lever are often dashpots, springs, sliding links, etc., in many different arrangements, all with the objective of modifying the dynamic characteristics of the governor. Despite their widely varying appearance, hydraulic servo gover-

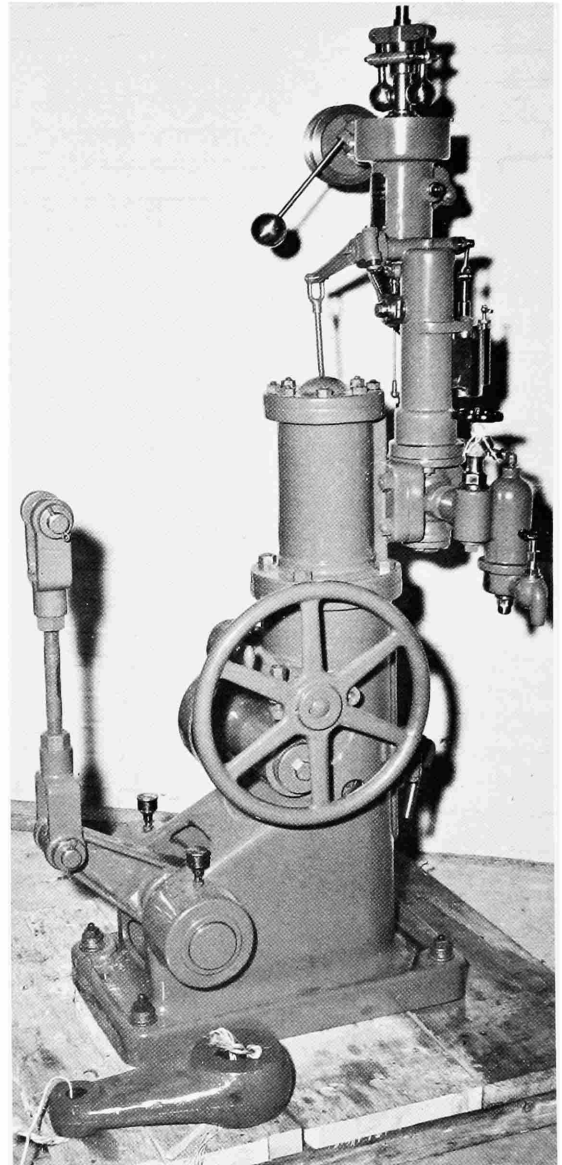

FIGURE 48.—Woodward "Type LR" water turbine governor with hydraulic servomotor, about 1914. (NMHT 315858. Smithsonian photo 45926-L.)

nors can always be reduced to the simple scheme described above.⁴⁵

The Lombard Governor Co. of Ashland, Massachusetts, began the manufacture of hydraulic governors in 1894. The Lombard "Type F" waterwheel governor (Figure 47)

45. Trinks, *Governors*, pp. 170-194.

in our collection (built in 1912; NMHT 320136; Accession 241096; serial no. 2113; size 44"×18"×62") was the smallest model made by this company; it is powered not by oil but by high-pressure water simply taken in from the river upstream of the turbine. The whole regulating apparatus is mounted on an iron table. The four-ball Pickering-type governor at the top controls through a vertical pilot valve the horizontal power cylinder. The piston rod carries a rack that drives a gear segment to move the turbine gate and the conspicuous feedback levers which modify the opening of the pilot valve. The Museum (Division of Mechanical and Civil Engineering) has also a considerable archival collection of linen drawings, mostly on governor installation, of the Lombard Governor Co.

The next stage in the development of hydraulic servo governors is represented by a Woodward "Type L-R" governor (Figure 48) of approximately 1914 (NMHT 315858; Accession 221780; name plate "WOODWARD WATER WHEEL GOVERNOR TYPE L-R; FT.LBS. 1,250; SIZE 5 × 4.75; No. 4100—WOODWARD GOVERNOR CO., ROCKFORD, ILL. U.S.A. PATENTS: MAY 31, 1870; AUG. 11, 1890; JULY 15, 1890; DEC. 15, 1896; JULY 30, 1901; AUG. 11, 1914"; size 32"×16"×66"). Powered by high-pressure oil, this governor is designed as a single compact unit. Its most interesting feature is the *double relay*. To make the governor more sensitive, fast-acting, and powerful, the pilot valve had acquired such size that it could not be moved without great effort. Another smaller pilot valve was therefore superimposed, which treated the first pilot valve as though it was the power piston. Both servomotors are enclosed in feedback loops by means of linkages connecting the two piston rods in a suitable manner with the governor spindle. The governor is equipped with numerous accessories, such as a belt safety stop, adjustments for sensitivity, a hand wheel for manual control, and a small electric motor, the *synchronizing motor*, to adjust the tension on the speeder spring re-

motely from the switchboard in order to vary the turbine speed.⁴⁶

Speed Regulation of Steam Turbines

Charles A. Parsons, the inventor of the first practical steam turbine, employed on his earlier models a most unconventional method of speed control. It is demonstrated on his fifth turbine (Figures 49–51), constructed in 1884 or 85, now in the collection of the National Museum of History and Technology (NMHT 311875; Accession 153831; built by Clark, Chapman, Parsons & Co., Gateshead-on-Tyne, England; 10 electr. hp at 18,000 r.p.m.). Its speed-sensing device, a centrifugal fan *F*, creates on its suction side a vacuum which is considered roughly proportional to the speed. Simultaneously, the vacuum generated by the fan also serves to circulate lubricating oil. A large spring-loaded leather diaphragm *L*, connected to the vacuum, is linked by a rigid rod to the throttle valve *V* in such a fashion as to reduce the steam flow to the turbine with increasing speed. Coupled with this purely mechanical system of speed control is an electrical fine adjustment. A metal pipe *Y* connected to the vacuum system has its opening at the top of the generator *G*. A spring-loaded baffle pivoting in front of the opening is actuated by the magnetic field of the dynamo, so that with increasing output voltage the vent hole is closed, causing an increase of vacuum and hence a decrease in turbine speed. In the case of decreasing generator output the vent is opened, so that the vacuum will sink, resulting in an opening of the throttle valve. Parsons claimed that "So accurate is the addition, that, when the load is gradually varied from nothing up to the maximum, the variation in volts at the terminal is less than one per cent." On the turbine exhibited, the diaphragm and the ro-

46. *Ibid.*, pp. 181–184.

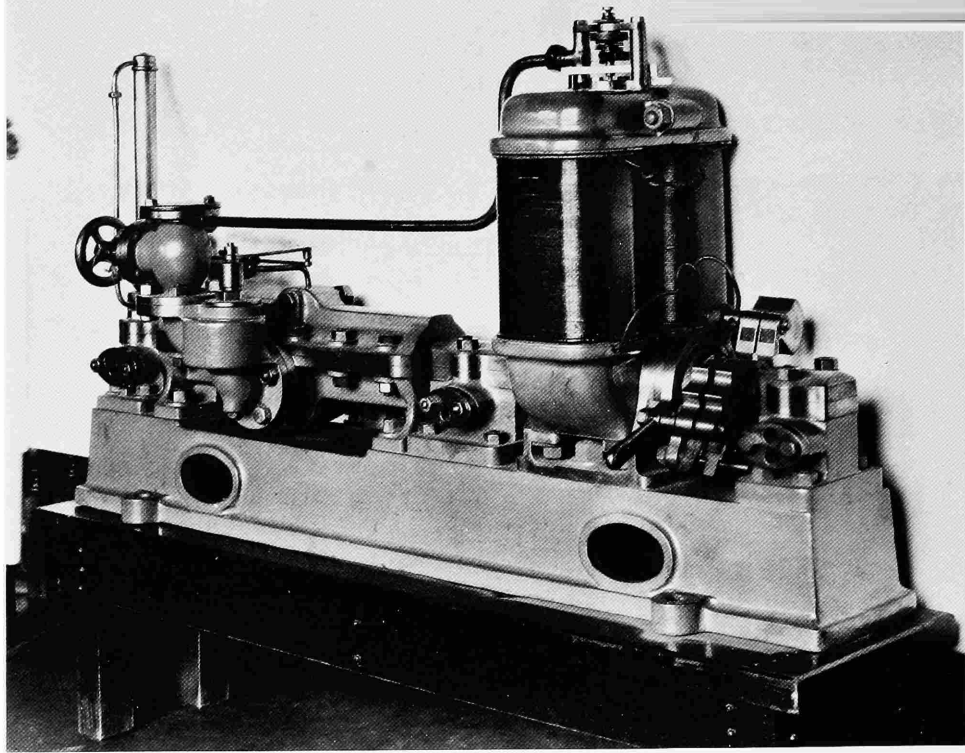

FIGURE 49.—Parsons steam turbine, about 1885. (NMHT 311875. Smithsonian photo 34043-C.)

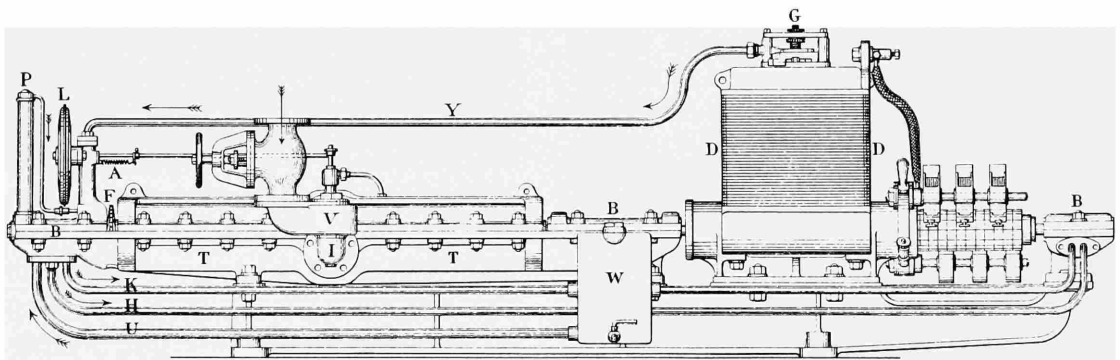

FIGURE 50.—Drawing of a Parsons steam turbine similar to NMHT 311875. Reprinted from the *Proceedings of the Institution of Mechanical Engineers*, 1888, pl. 85.

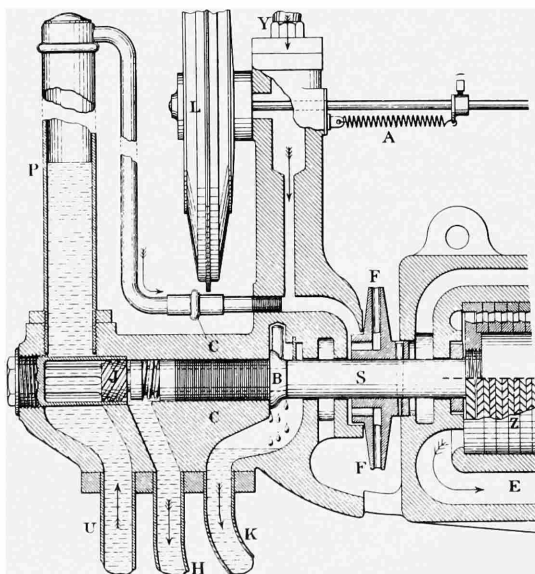

FIGURE 51.—Governor details of a Parsons steam turbine. Reprinted from the *Proceedings of the Institution of Mechanical Engineers*, 1888, pl. 86.

tary baffle on the yoke of the generator are missing.⁴⁷

In 1889 Parsons terminated his relationship with Clarke, Chapman & Co. and founded a firm of his own at Newcastle-upon-Tyne. Since the former company retained the rights to his patents, he had to resort to inventing a totally new steam turbine, the radial-flow turbine, as well as a new method of governing. The latter, which has become known as "gust-governing," has been implemented in a number of different ways; its basic principle was to admit the steam not in a steady flow but intermittently in periodic "gusts." Its advantage was that the control mechanism, avoiding static friction by being continuously in motion, would be more responsive to small deviations of speed. In some

designs the duration of the "gust" was directly controlled by the governor; in others, as for example on the Parsons turbogenerator of 1905 (Figure 52), an oscillatory motion generated by an eccentric was simply superimposed on the action of a conventional system by proportional control (NMHT 322000; Accession 243961; serial no. 1025; steam pressure 100 p.s.i.g., no superheat, vacuum 27" hg.; designed for an output of 20 KW, 110 volt A.C., 182 amp., at frequency of $83\frac{1}{3}$ CPS, speed 5000 r.p.m.; 2-pole generator compound-wound with compensating coils). The governor employed here consists of a shunt solenoid mounted on the alternator. The core of the solenoid, suspended from above by a spring, is drawn downward with rising current output, that is, increasing speed. It is directly connected with the steam inlet valve, so that a downward motion of the core leads to the closing of the throttle valve. The special feature of Parsons' "gust-governing" is the following: the pivot point

47. Charles A. Parsons, "Description of the Compound Steam Turbine and Turbo-Electric Generator," *Proceedings, Institution of Mechanical Engineers* (1888):485; Robert H. Parsons, *The Development of the Parsons Steam Turbine* (London, 1936), pp. 7-8.

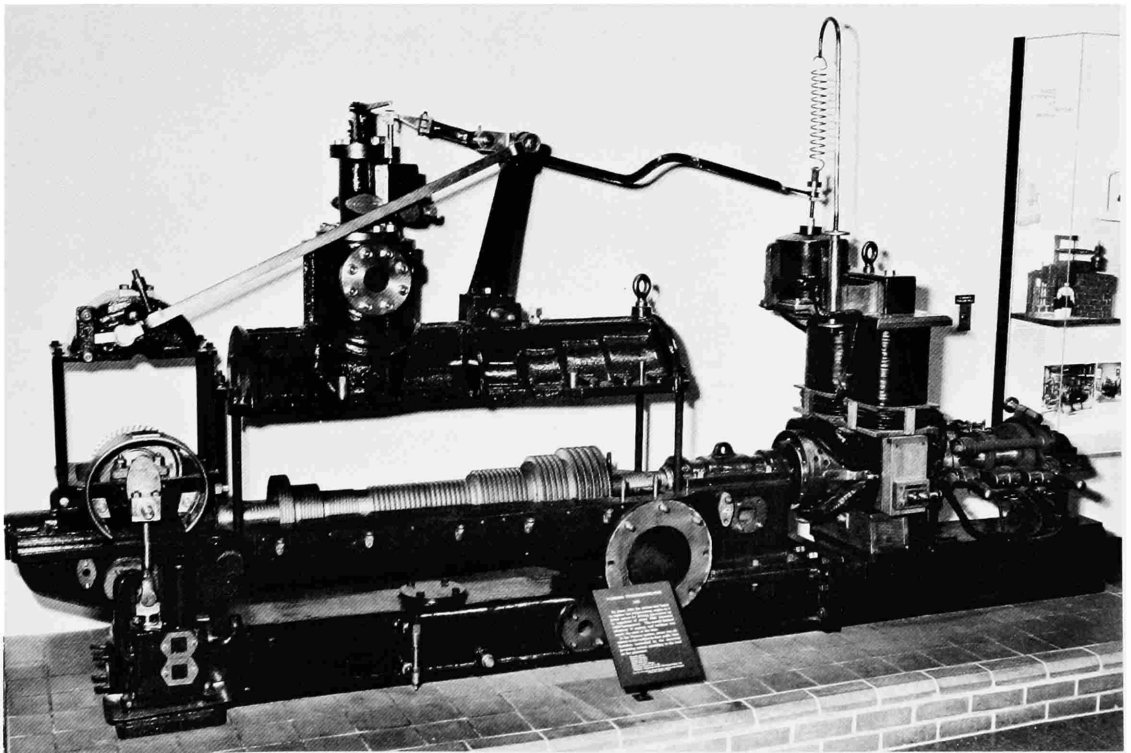

FIGURE 52.—Parsons steam turbine of 1905. (NMHT 322000. Smithsonian photo 72172.)

of the lever connecting the core of the solenoid with the control valve is not fixed but oscillates vertically, being driven by an eccentric geared to the turbine shaft. This oscillation, independent in period and frequency of the governor action, serves only to keep the control system "alive"—i.e., in constant action—in order to avoid the sticking of any elements after prolonged periods of equilibrium. The frequency of steam blasts was initially about 160 to 180 per minute, later approximately twice that. Another notable feature of this system is the throttle valve: it is servo powered, using as a source of power steam that has leaked through the bushings of the throttle valve. When finally, about 1919–1920, "gust-governing" was displaced by oil-powered hydraulic systems because of the stricter requirements of high-pressure

steam, its passing was regretted by many engineers.⁴⁸

The early turbines of Gustav de Laval (1845–1913), the Swedish steam turbine pioneer, were regulated more conventionally than those of Parsons. Laval's turbines were first put into series production in 1892. The 10-hp unit exhibited in our Museum was shown at the World's Columbian Exposition at Chicago, 1893 (NMHT 314843; Accession 210798; capable of 10 to 20 hp at turbine speeds of about 20,000 to 30,000 r.p.m.; drives D.C. generator through reduction gear). The same turbine also served as a patent model, persuading the U.S. Patent Office to grant

48. Robert H. Parsons, *The Development of the Parsons Steam Turbine*, pp. 16–17, 41, 145; Robert M. Neilson, *The Steam Turbine*, 2nd edition (London, 1903), pp. 170–174.

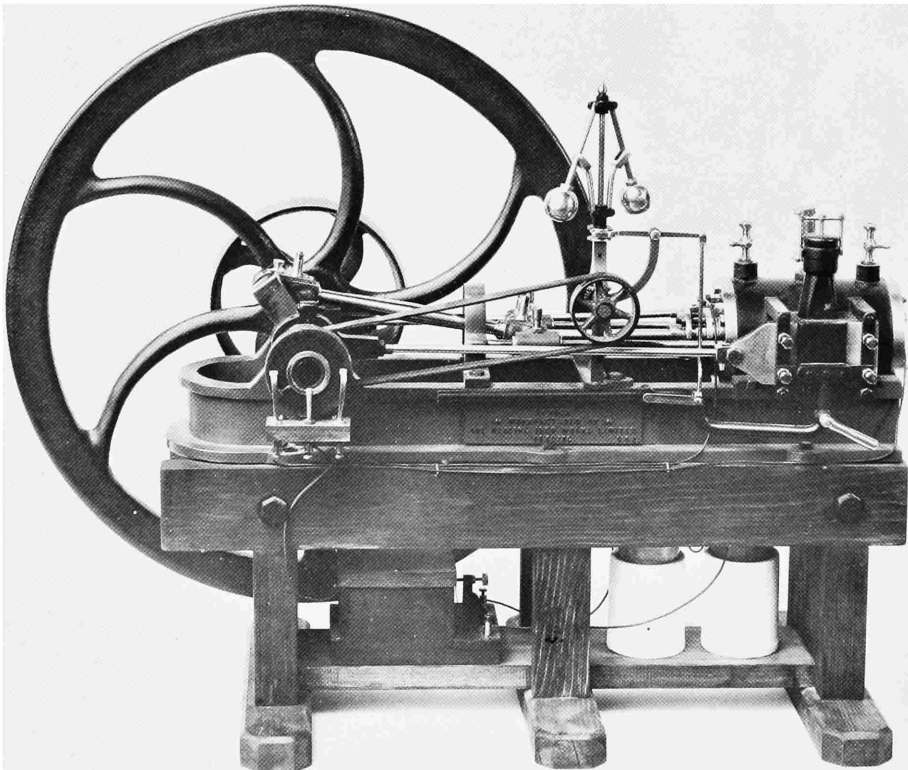

FIGURE 53.—Model of a Lenoir gas engine of about 1860. (NMHT 315042. Smithsonian photo 43952-A.)

de Laval in 1894 a patent he had applied for in 1888. A flyweight governor mounted on the low-speed shaft of the reduction transmission is somewhat difficult to recognize, because it is totally enclosed in a small cylindrical capsule. In traditional fashion the governor acts through a simple arrangement of levers on the throttle valve in the steam inlet line.

Similar is the speed control system of the Terry steam turbine of 1910 (NMHT 314820; Accession 210004; serial no. 467; 58 hp at 2500 r.p.m.). A flyweight governor mounted on the turbine shaft is directly connected to a throttle valve in the steam line.

An example of more modern turbine regulation is the three-stage Curtis turbine built by the General Electric Co. in 1927 (NMHT 309881; Accession 106194; type DS-53-3; serial no. 38769; 50/100 hp, 500/7800 r.p.m.). The centrifugal governor is integrated into an oil-powered servo system. It positions a horizontal beam in the steam chest to which all the valves for the individual inlet nozzles are attached. Also included are a synchronizing motor for remote speed adjustment and an overspeed-shutdown mechanism to prevent dangerously high speeds.

Speed Regulation of Internal Combustion Engines

During the second half of the nineteenth century, the internal combustion engine became an important rival to the steam engine. At first its speed was controlled by governors derived directly from the steam engine, but soon distinctive new types emerged that took into account the peculiarities of the new engine.

The speed-control system on the model of a Lenoir gas engine of about 1860 (model made at the Museum in 1957 after an engine built by the Lenoir Gas Engine Co. of London; NMHT 315042; Accession 214268) is clearly patterned (Figure 53) after that of the steam engine. A governor in the style of Watt's original design actuates a throttle valve in the fuel gas intake line. Con-

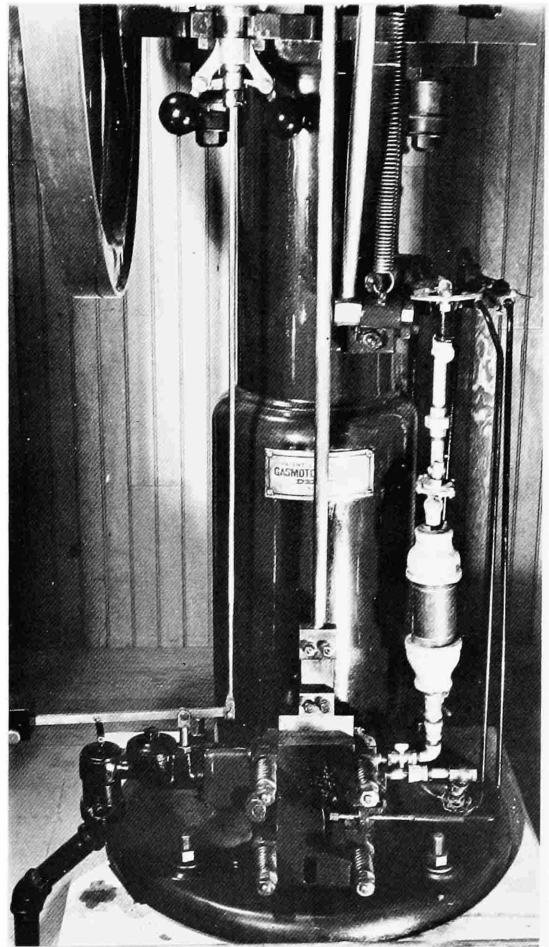

FIGURE 54.—Otto & Langen atmospheric gas engine, 1872. The governor (top) acts on the exhaust valve (bottom). (NMHT 314658. Photo CLG.)

trolled in the same manner is the Buick gasoline engine of 1902 (NMHT 319024; Accession 236000; a vertical single-cylinder four-stroke watercooled stationary engine, marked "THE BUICK MFG. CO., H.P.4, NO. 567, DETROIT, MICH."). A centrifugal governor behind the flywheel acts on a throttle valve in the intake line between carburetor and cylinder. This method of speed control is still in use. The Lorimer gasoline engine "Sturdy Scott" of the 1940s (NMHT 328394; Accession 272466; single cylinder vertical stationary engine of 8 hp at 600 r.p.m.) is equipped with a centrifugal governor acting on a throttle in the intake manifold (type

"GC 1107.2.8," by Pierce Governor Co., Anderson, Indiana), which is, with minor modifications, still being produced.⁴⁹

A small step toward an independent mode of control was taken in the atmospheric free-piston gas engine of Otto & Langen, 1872 (NMHT 314658; Accession 207779; ½ hp; marked "PATENT LANGEN & OTTO GASMOTOREN FABRIK DEUTZ NO. 537"). Its governor (Figure 54), according to the special character of the power stroke of this engine, acts on a throttling valve located in the exhaust line.

The majority of speed-control systems for internal combustion engines can be divided into two classes: proportional control, where the rate of fuel intake can be varied continuously in relation to the speed by various proportioning devices; and "hit-and-miss" control, where in the case of part-load operation whole power strokes are omitted. Of both, the hit-and-miss method was the cheaper and

the shorter lived one. It was best suited for four-stroke engines using gas or gasoline, where for proper functioning an optimum fuel-air mixture was critical.

The system of hit-and-miss governing is well demonstrated on the "Silent" Otto gas engine of about 1880 (NMHT 323495; Accession 250990; a single-cylinder horizontal four-stroke gas engine of 2 hp at around 180 r.p.m., built since 1876 by the "Gasmotoren-Fabrik Deutz," serial no. 4417). In the side view of the engine (Figure 55) the governor is located on the lower left. Its appearance is somewhat untypical because the revolving flyballs are covered, presumably for reasons of safety, by a bowl-shaped hood. The top of the governor is connected by a bell crank to a small sleeve sliding on the horizontal lay shaft which powers the governor and slide valve. This sleeve, free to move horizontally but constrained to rotate with the shaft, carries a narrow cam which opens the gas inlet valve during a certain part of the suction stroke. At excessive speeds the slide moves to the

49. A. L. Dyke, *Automobile and Gasoline Engine Encyclopedia*, 22nd edition (Chicago, 1952), p. 947.

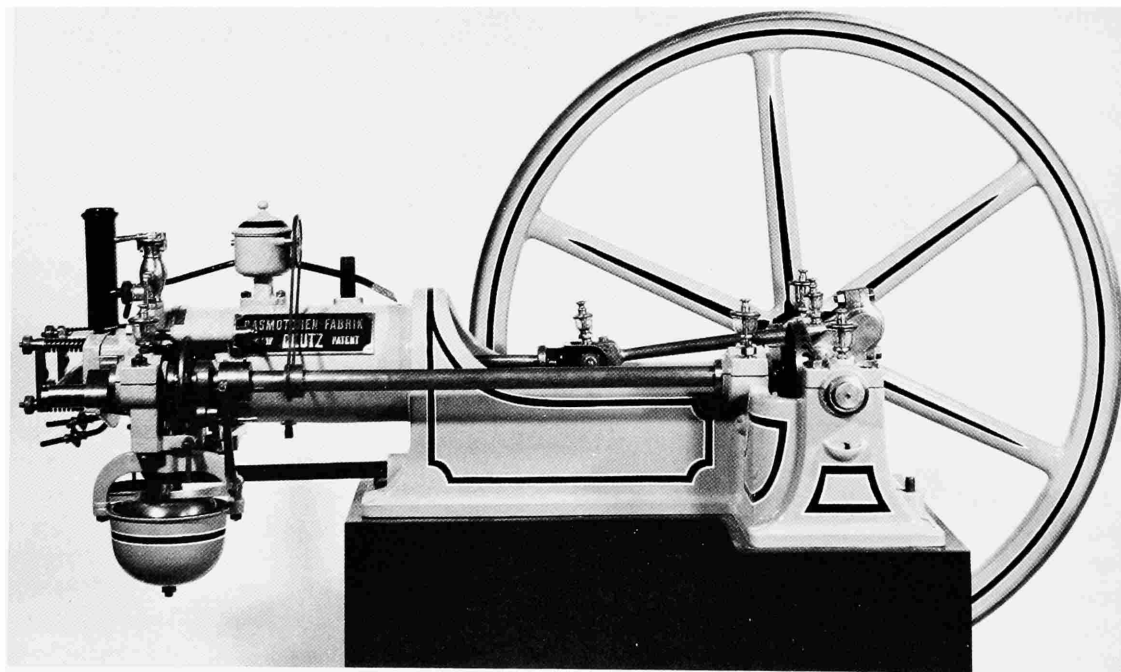

FIGURE 55.—"Silent Otto" gas engine, about 1880. The centrifugal governor is protected by a bowl-shaped hood (left, bottom). (NMHT 323495. Smithsonian photo P65778.)

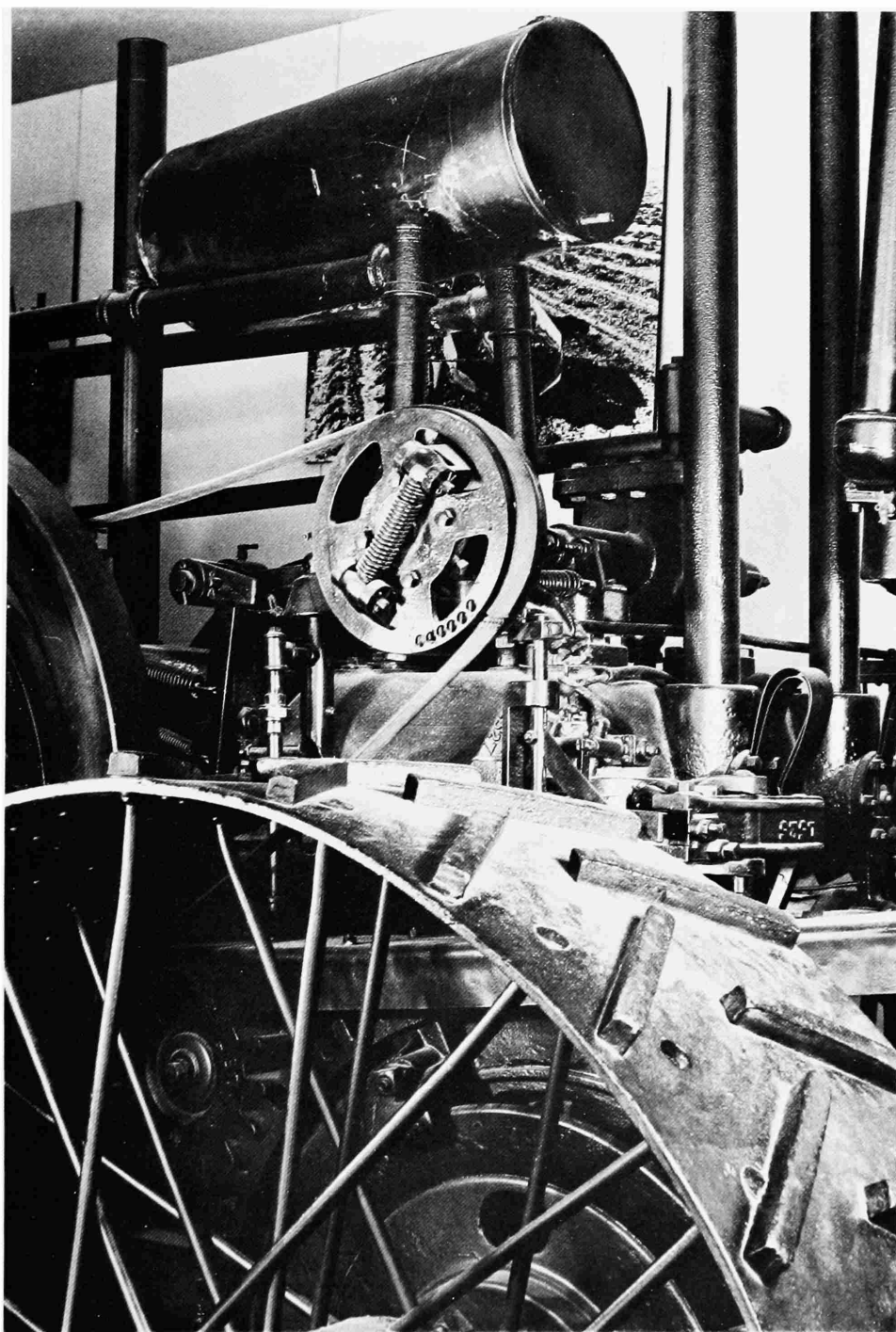

FIGURE 56.—Centrifugal governor on Hart-Parr agricultural tractor, 1903.
(NMHT 60A74. Photo CLG.)

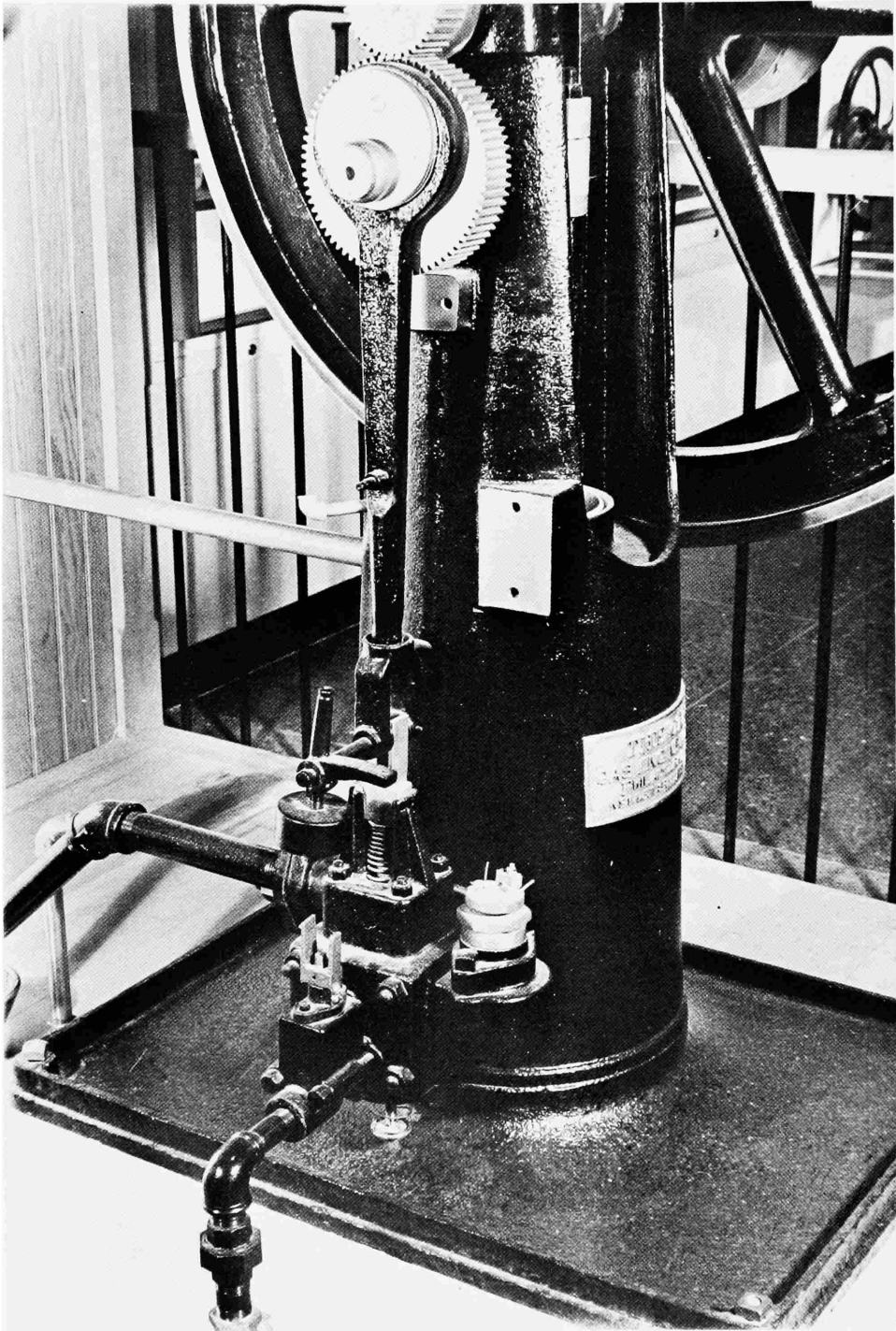

FIGURE 57.—Vertical Otto gas engine, about 1895 with a "pendulum" governor (incomplete, bottom). (NMHT 311902. Photo CLG.)

right so far that the cam will miss the valve lifter. The engine, receiving no fuel during the whole cycle, is thus decelerated until it runs again at the desired speed. Because of its inherent irregularity, large flywheels were needed in this method of control; on the other hand it was inexpensive, simple of construction, and above all highly economical with regard to fuel consumption.⁵⁰

The same control system is also employed on two other "Otto" engines in the Museum's collections, both of the same type as the above one, and both built in Philadelphia by Schleicher, Schumm & Co. or their successor, the "Otto Gas Engine Works" (1. NMHT 309556; Accession 104812; built in 1882; serial no. 554; rated 4 hp at 160 r.p.m.⁵¹ 2. NMHT 323697; Accession 242800; built around 1910, serial no. 6690; 9.5 hp at 300 r.p.m.), and on a White & Middleton gasoline engine of 1897 (NMHT 325904; Accession 256985).

Similar to this is also the speed regulation of the two-cylinder four-stroke kerosene engine on the huge Hart-Parr agricultural tractor of 1903 (NMHT 60A74; Accession 230442). Again a centrifugal governor (Figure 56) acts on a system of latches which make the fuel inlet valves inoperative at above-normal speeds.

A hit-and-miss system of very unusual character is the "pendulum" governor—not to be confused with the centrifugal pendulum—which measures velocity not in terms of centrifugal force but by the inertia effect of a pendulum suspended from some reciprocating member of the engine. On the vertical "Otto" gas engine (Figures 57 and 58) of about 1895 (NMHT 311902; Accession 156547; Otto Gas Engine Works, Philadelphia, serial no. 4765; 2 hp at 300 r.p.m.) the pendulum is suspended at the bottom of the eccentric rod in such a manner that at normal speed it will engage and open the gas intake valve once every

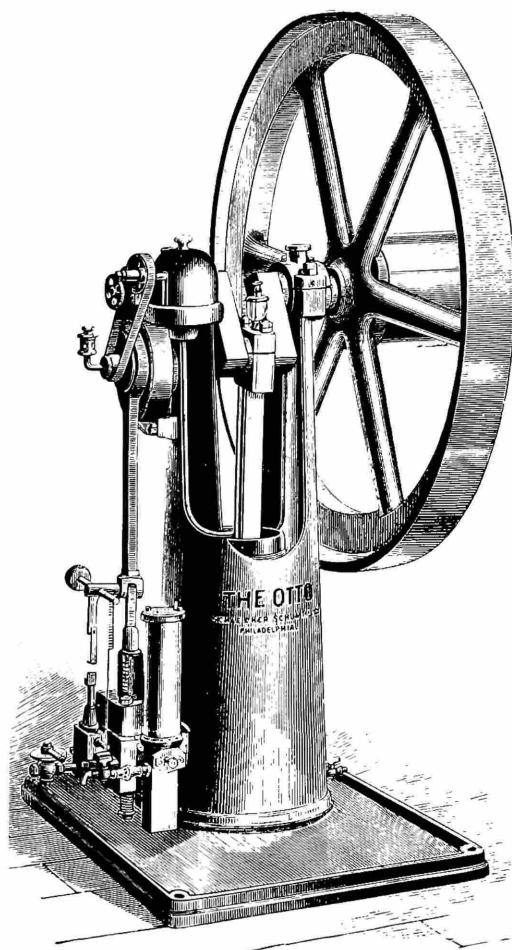

FIGURE 58.—Contemporary drawing of a vertical Otto engine similar to NMHT 311902, showing the "pendulum" governor in working condition. Reprinted from The Otto Gas Engine Works, *Catalog of the "Otto" Gas Engine* (Philadelphia, no date [about 1897]), p. 9.

cycle. At excessive speeds, however, the latch on the pendulum will, due to its inertia, miss the valve, and the engine will run without fuel until it has returned to normal speed. The pendulum governor on this particular engine is not complete.

Another variation on the theme of hit-and-miss control is demonstrated on a small stationary "Domestic" gasoline engine of about 1905 (NMHT 329792; Accession 282826; marked "MADE BY DOMESTIC ENGINE AND PUMP CO. SHIPPENSBURG, PENN-

50. Dugald Clerk and G. A. Burls, *The Gas, Petrol, and Oil Engine*, 2 vols., 2nd edition (New York, 1913), II:362-363; Friedrich Sass, *Geschichte des deutschen Verbrennungsmotorenbaues von 1860 bis 1918* (Berlin, 1962), pp. 45-46.

51. Taylor, *Catalogue of Mechanical Collections*, p. 156.

SYLVANIA. No. 682 H.P. 1½"). A shaft governor of the simplest possible construction—a weight sliding radially along a shaft fixed to one spoke of the flywheel—acts through a variable-throw eccentric on the exhaust valve which it arrests at overspeed in its open position, thus preventing the engine from drawing in fresh fuel. When the speed has returned to its normal value, the exhaust valve will be released again. Hit-and-miss control similar to this—where a centrifugal governor acts simultaneously upon the exhaust valve and the ignition circuit—is employed on an Olds gasoline engine (Figure 59) of about

1910 (NMHT 315111; Accession 216224; marked "SELF CONTAINED GASOLINE ENGINE, NO. 8482-3A PATENTED. MANUFACTURED BY OLDS GASOLINE ENGINE WORKS, LANSING, MICH., USA"), and on the "Aermotor" gasoline engine, also of about 1910 (NMHT 316806; Accession 228815).

In spite of its economy, hit-and-miss regulation eventually lost its popularity. It was far too inaccurate for generation of electricity. Besides it was somewhat unreliable, and the discontinuity of its operation made large flywheels necessary. In the beginning of the

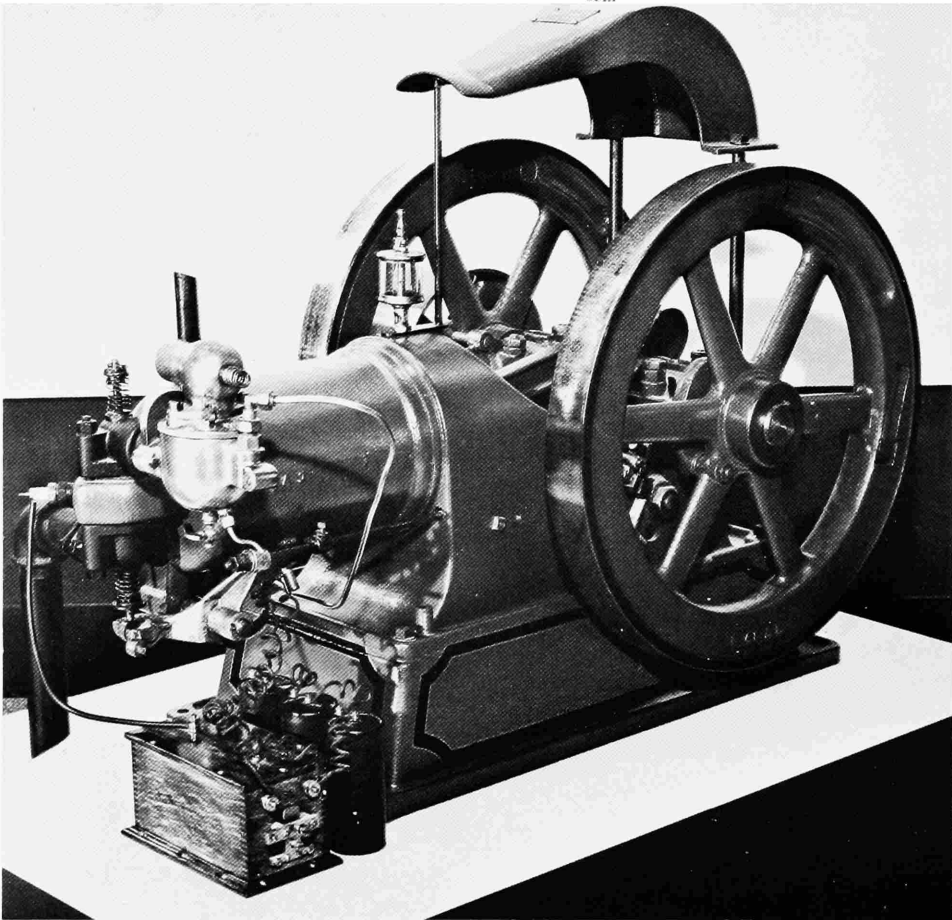

FIGURE 59.—Olds gasoline engine, about 1910. The right flywheel carries a simple shaft governor which actuates the "hit-and-miss" control through the horizontal rod on the lower right of the cylinder. (NMHT 315111. Smithsonian photo 45926-A.)

twentieth century it was gradually replaced. The systems of speed control that prevailed employed the proportional response, where the corrective action was proportional to the deviation of the actual from the desired speed. The simplest case—throttling control—has already been discussed. The remaining examples of this in the Museum's collection all have one feature in common: all employ centrifugal governors acting on some proportioning mechanism by which the amount of fuel per cycle introduced into the cylinder can be varied.

The oldest of these regulators is installed on the Brayton oil engine (Figure 60) of about 1877 (NMHT 313703; Accession 192653; rated 2 hp at 250 r.p.m.; used for driving an arc-light dynamo at Brown University). A spring-loaded centrifugal governor on a horizontal spindle determines the axial position of a cam sliding axially and rotating with the spindle. A roller running on the cam actuates a valve lifter of the fuel intake valve. The

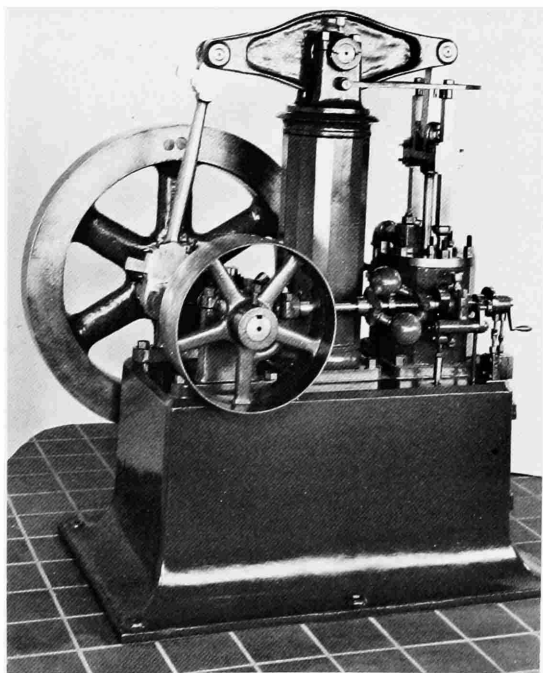

FIGURE 60.—Brayton oil engine, about 1877. (NMHT 313703. Smithsonian photo 56027.)

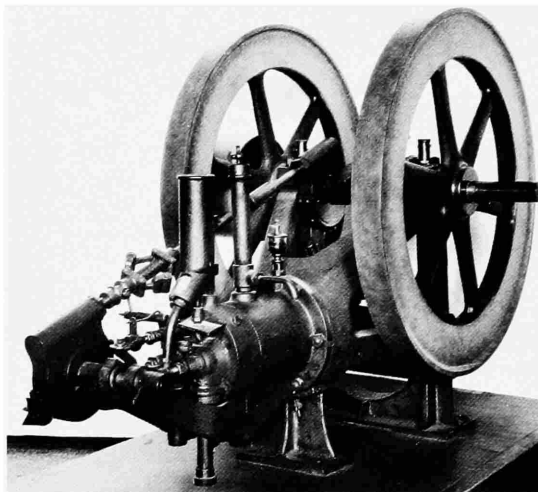

FIGURE 61.—Atkinson "Cycle" gas engine, 1889. (NMHT 310371. Smithsonian photo 31381-A.)

cam is shaped three-dimensionally, its width varying along the axis, so that the period of valve opening depends on the axial position of the cam. With increasing speeds the governor then moves the cam in such a direction that the period of fuel admission is shortened.⁵²

The speed control of the Atkinson "Cycle" four-stroke gas engine (Figure 61) of 1889 is similar (NMHT 310371; Accession 117006; 2 hp; serial no. 416).⁵³ A spring governor controls the opening of the gas intake valve by inserting a stepped wedge more or less far between the valve lifter and the rotating cam.

The Hornsby-Akroyd hot-bulb oil engine (Figure 62), about 1893–1895 (NMHT 309637; Accession 106378; 4 hp at 225 r.p.m.; serial no. 1501), is equipped with a loaded governor acting on a bypass valve in the oil supply line, which at overspeed diverts some of the fuel oil back to the oil tank in the base plate of the engine.

On the Mietz & Weiss one-cylinder two-stroke hot-bulb oil engine, about 1906 (NMHT 319407; Accession 236710), a cen-

52. R. C. Carpenter and H. Diederichs, *Internal Combustion Engines*, 3rd edition (New York, 1910), p. 250.

53. Taylor, *Catalogue of Mechanical Collections*, p. 157.

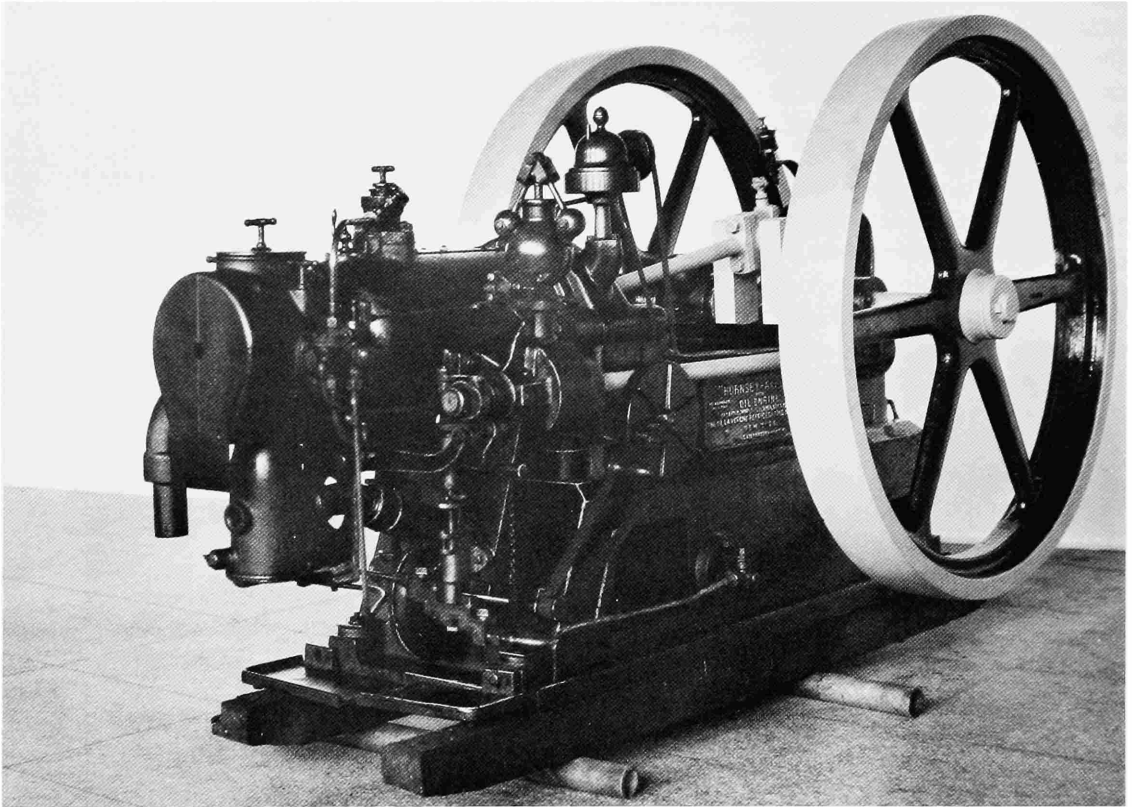

FIGURE 62.—Hornsby-Akroyd hot-bulb oil engine (about 1893) with a Porter-type governor (foreground). (NMHT 309637. Smithsonian photo 6092.)

trifugal shaft governor adjusts the length of stroke of the fuel pump according to the load by means of shifting the eccentric on the main shaft.⁵⁴

Diesel engines were usually controlled by conventional flyball governors acting on some proportioning mechanism in the fuel-oil pump which varied the amount of fuel injected into the cylinder at every stroke. The earliest example of this in our collection is the M.A.N. single-cylinder vertical Diesel engine of 1903 (NMHT 314945; Accession 211077; type "DM 8", 8 hp at 270 r.p.m., marked "Vereinigte Maschinenbaufabrik Augsburg und Maschinenbaugesellschaft Nürnberg A.G., Werk Augsburg, No. 443 Wärme-Motor 'Patent Diesel' 1903"). The fuel pump is a

54. Carpenter and Diederichs, *Internal Combustion Engines*, p. 384.

plunger pump where the discharge valve is uncontrolled, while the suction valve is directly linked with the governor (Figure 63), so that the engine speed determines the duration of opening of the suction valve of the fuel pump. The fuel pump is a replica built in the Museum after original drawings (not operational).⁵⁵

On the three-cylinder Diesel engine built by the American Diesel Engine Co. in 1905 (NMHT 316726; Accession 227588; serial no. 151; 120 hp at 220 r.p.m.), a flyball governor (Figure 64) similarly controls the opening time of the suction valve of the fuel pump,

55. Hugh Güldner, *The Design and Construction of Internal-Combustion Engines*, trans. H. Diederichs (New York, 1910), pp. 267, 362; F. E. Junge, "Technical Aspects of Oil as Fuel," *Power* (18 February 1908), p. 255, fig. 46.

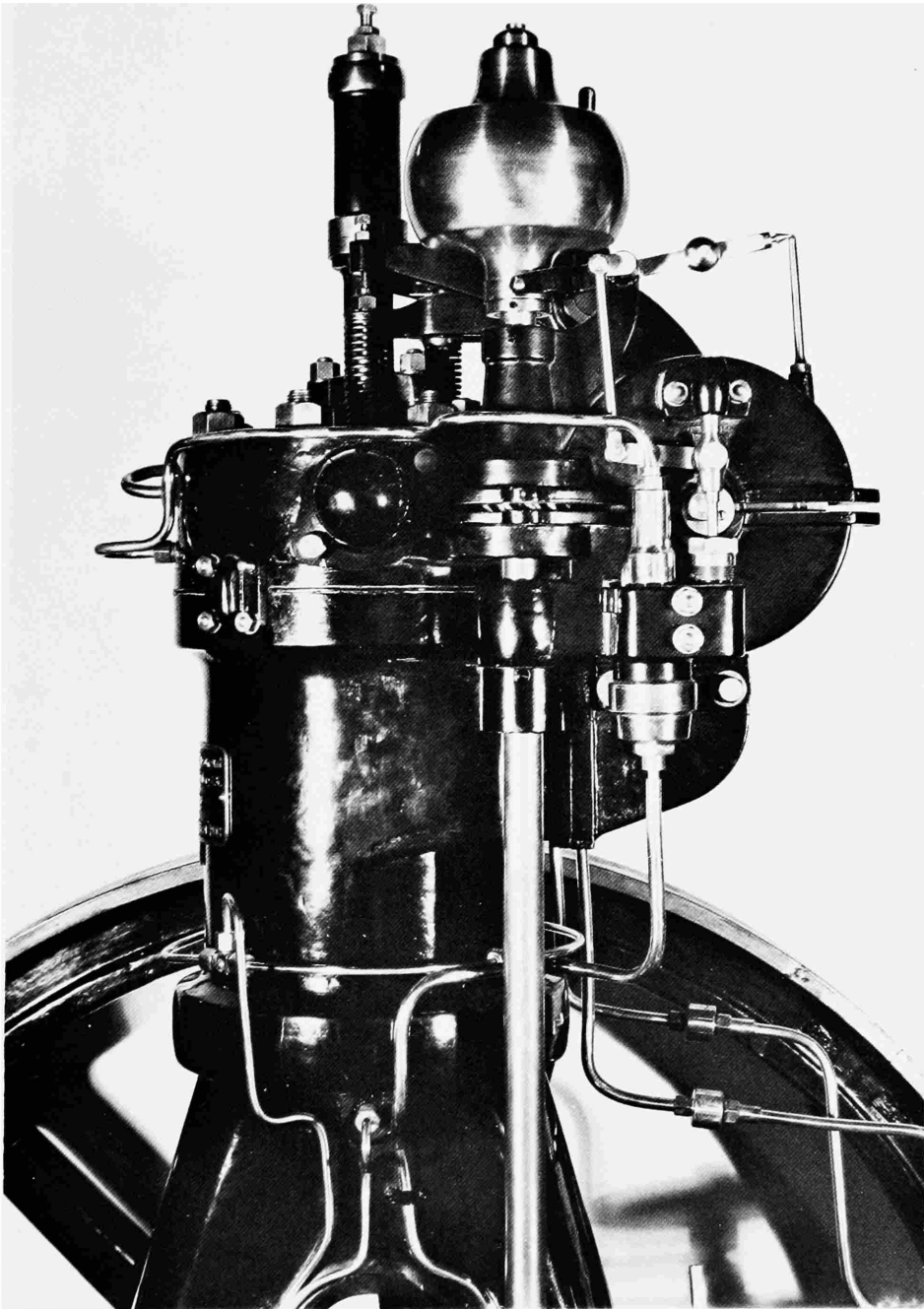

FIGURE 63.—Upper part of M.A.N. Diesel engine of 1903 with governor (top, enclosed) and fuel valve. (NMHT 314945. Photo CLG.)

although not by the linear motion of a linkage but rather through the rotation of a cam.⁵⁶

⁵⁶ G. Güldner, *Internal Combustion Engines*, pp. 430-433.

In contrast to the two preceding systems where the speed of Diesel engines is regulated by manipulating the suction valves of the fuel injection pump, the governor (Figure

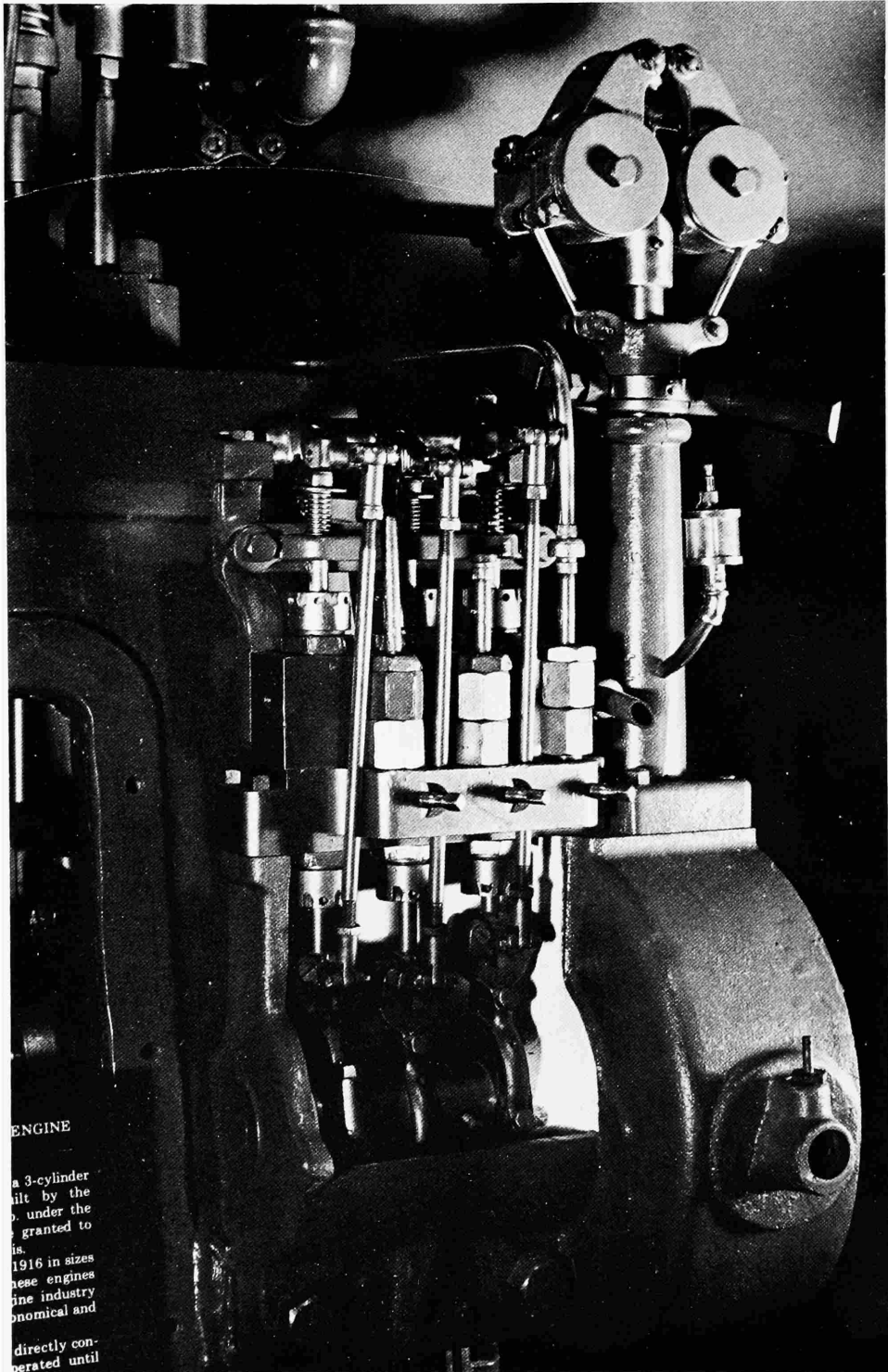

FIGURE 64.—Three-cylinder "American Diesel" engine, 1905; detail view of governor and fuel pump. (NMHT 316726. Photo CLG.)

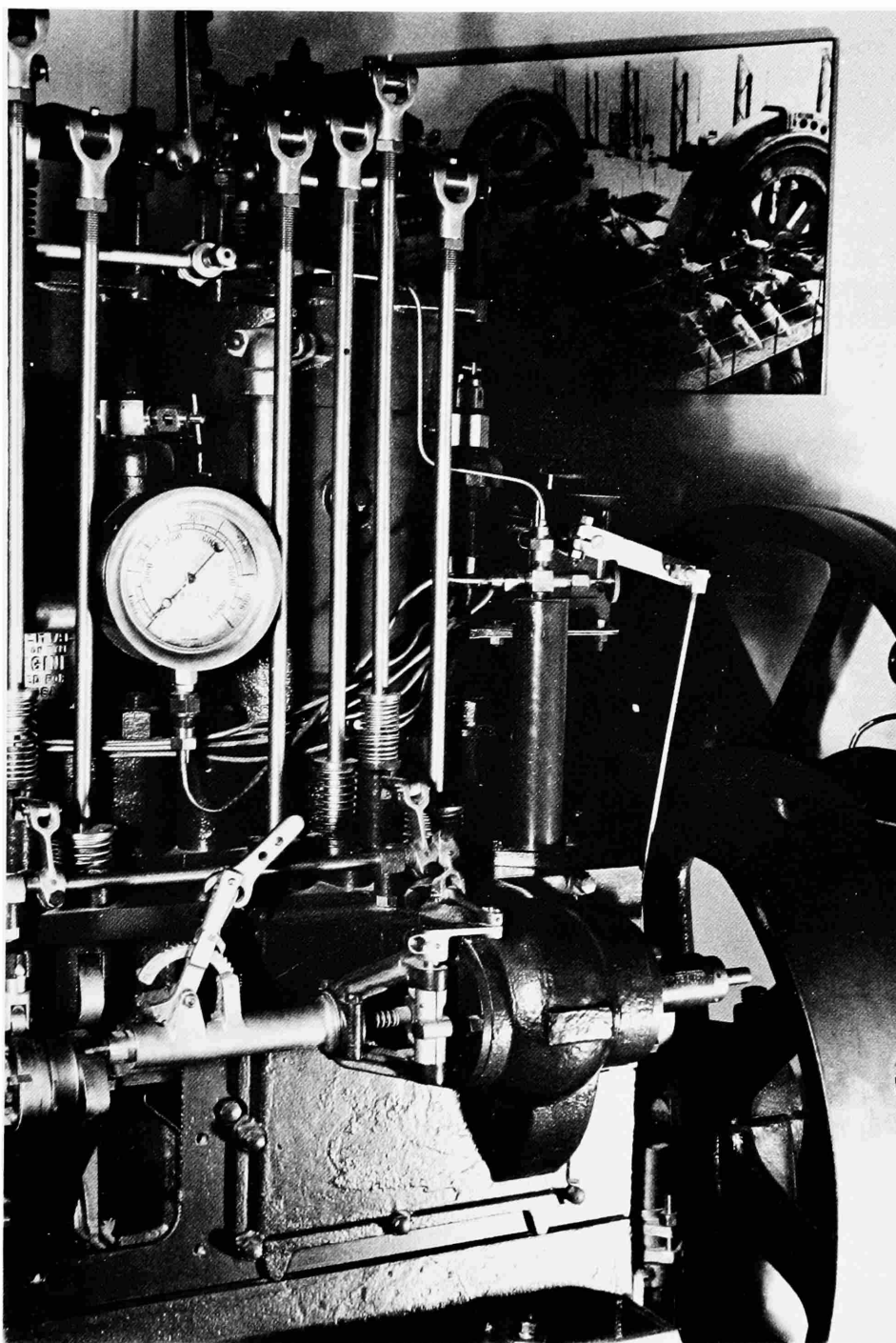

FIGURE 65.—Three-cylinder "Atlas-Imperial" Diesel engine, 1921; detail view of governor (enclosed in engine block) and mechanism for varying the valve-stroke. (NMHT 316578. Photo CLG.)

65) of the three-cylinder Atlas-Imperial marine engine, 1921, adjusts the opening period of the injection nozzle directly (NMHT 316578; Accession 223429; serial no. 8003; 55 hp at 320 r.p.m.). This is accomplished by inserting, to a variable degree, wedges between the valve lifter rods and the valve actuating cams. A pressure regulator in the fuel supply line keeps the supply pressure constant in the event of changes in fuel consumption. The desired engine speed can be easily adjusted by a control lever changing the initial tension of the governor spring.

The fuel injection pumps for automotive Diesel engines were often equipped with built-in governors. On Bosch fuel injection pumps, of which the Museum has specimens (Figures 66 and 67) of 1935 and 1944 (1. NMHT 311017; Accession 135324; type PE 4 D; marked "P200/1000 BC1: PHV1/1Z." 2. NMHT 312825; Accession 167594; marked "American Bosch GV A250/800B19 NS."), the

governors served to regulate the idling speed and to prevent overspeed, while in the normal working range the speed was controlled manually through the throttle lever. To accomplish this, the governor spring consists of a very soft spring and a very stiff spring arranged in series; the soft spring is in action at low idling speeds with the throttle lever at rest. In the normal working range the governor is inactive: the soft spring is fully compressed while the stiff spring is still uncompressed. The latter will respond only to the high centrifugal forces occurring at overspeed. The quantity of fuel injected is controlled by an ingenious method of changing the pump stroke directly: each plunger has on its side a conical groove so that its discharge per stroke depends on the plunger's angular position with respect to the inlet port. All plungers are connected through a rack-and-pinion arrangement with the output arm of the centrifugal governor. With increasing speed, the governor will rotate

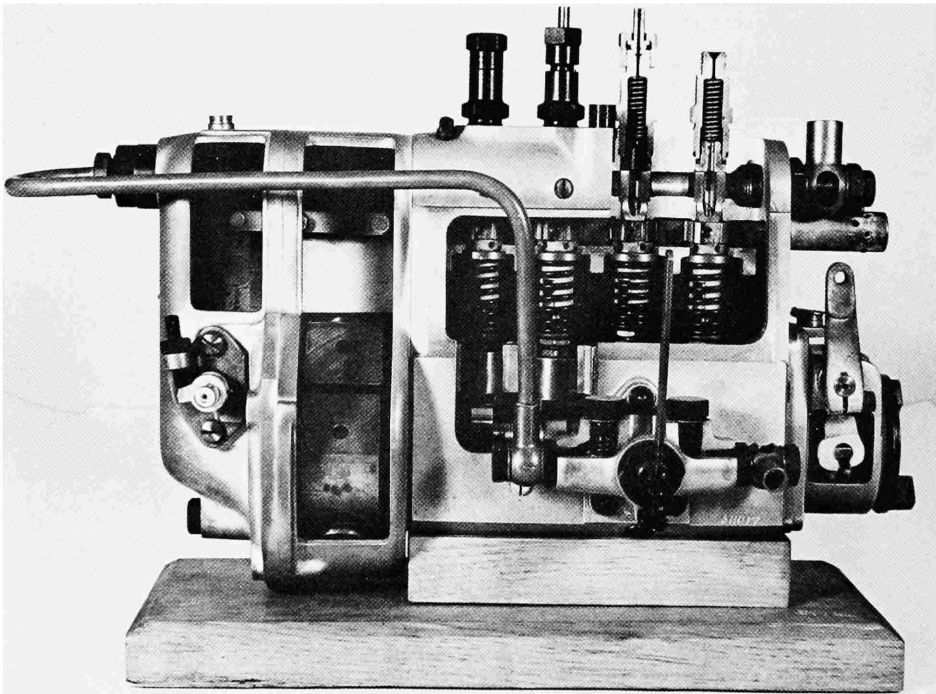

FIGURE 66.—Bosch "Type PE4D" fuel injection pump, 1935. The side of the governor is visible through the second opening from the left. (NMHT 311017. Photo CLG.)

the plungers in such a manner that by shortening their effective stroke it will decrease the discharge rate of the fuel injection pump.

In a more recent type of internal combustion engine governor, the function of speed regulation is completely separated from that of supplying fuel. These governors are compactly designed *black boxes* with only two external connections: an input link to the drive shaft and an output lever to some proportioning device in the fuel supply system. As direct descendants of the hydraulic water turbine governors, they include hydraulic servomotors powered by self-contained, high-pressure oil systems.

The Museum has three specimens of this type of governor. The oldest is a Woodward "Model SI" (Figure 68) from the early 1940s (NMHT 330029; Accession 288883; cutaway; $5\frac{1}{2}'' \times 8\frac{1}{2}'' \times 15\frac{1}{2}''$; on display stand $5\frac{1}{2}''$

high). The speed-sensing device is an arrangement of conventional spring-loaded flyballs, acting upon the pilot valve of a hydraulic servomotor. As will be recalled (Figure 46), in order to have proportional response, a hydraulic servomotor requires a feedback connection between the power piston and the pilot valve. On the Woodward "SI" governor, the feedback link is hydraulic, consisting of special hydraulic pistons both on the power piston and on the pilot valve, both working in cylinders connected by a pipe. The governor is capable, however, of more than merely proportional response. The feedback pipeline contains a needle valve providing a small opening to the oil sump. Through it oil can enter or leave the enclosed space of the feedback connection, so that the relationship between power piston and pilot valve is no longer rigid but instead flexible, adapting

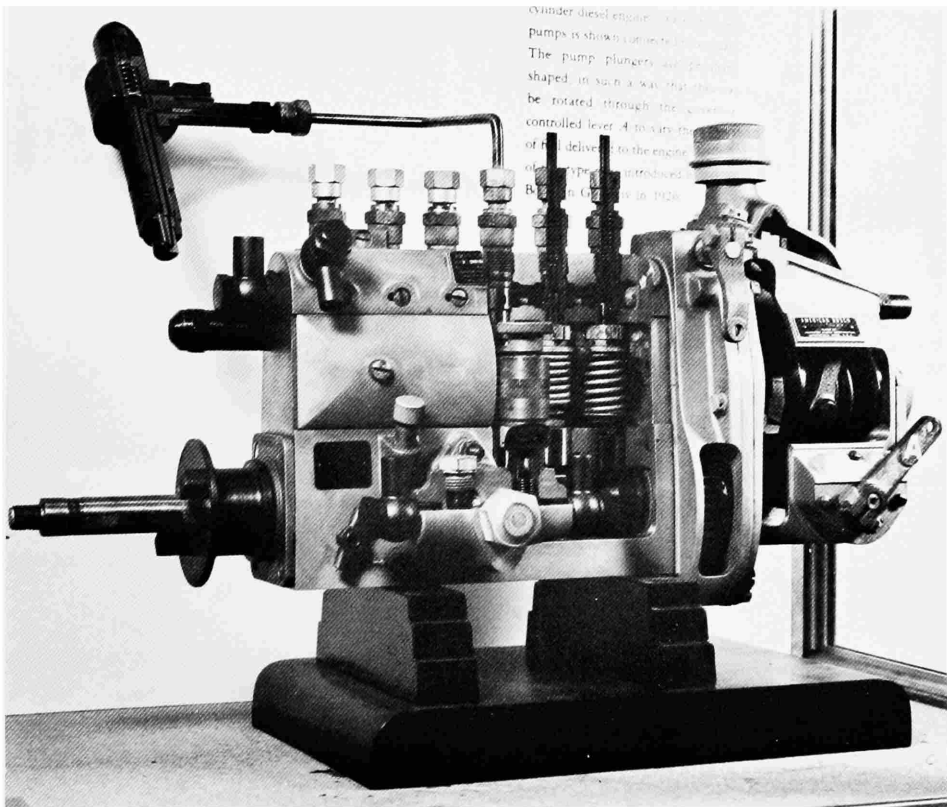

FIGURE 67.—American Bosch fuel injection pump, 1944. (NMHT 312825. Smithsonian photo 48438-L.)

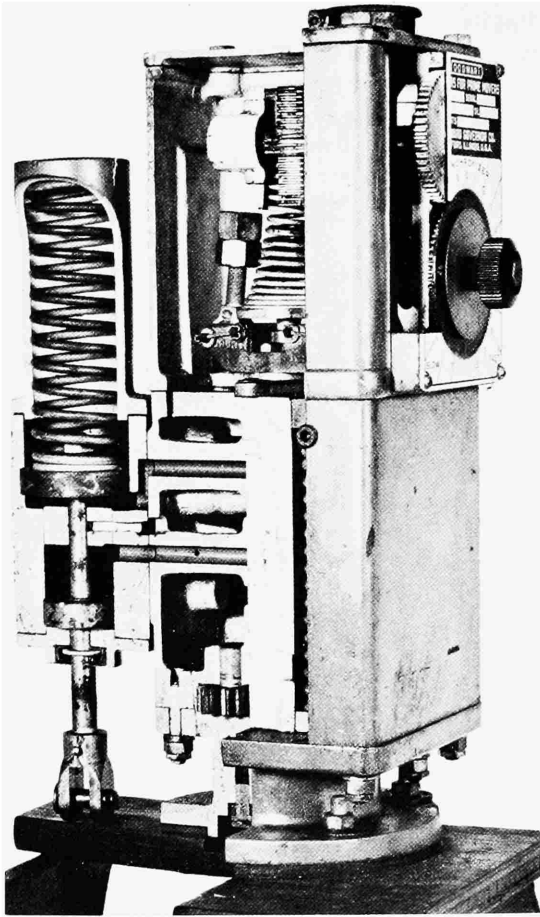

FIGURE 68.—Woodward "Model SI" engine governor with hydraulic servomotor, self-contained, about 1940. (NMHT 330029. Photo CLG.)

itself to the needs of the governor. As a result, the governor provides "proportional plus integral" control, that is, unlike a purely proportional regulator, it can keep the speed precisely constant regardless of load changes; or, in the words of its manufacturer, it is "isochronous." The desired speed can be set on a geared dial which determines the initial compression of the spring balancing the flyballs.⁵⁷

Slightly more recent is the governor "Model B117" (Figure 69) by the Marquette Metal

⁵⁷ Woodward Governor Company, *S.I. Governor, Dial Control; Bulletin 01030* (Rockford, Illinois, 1945).

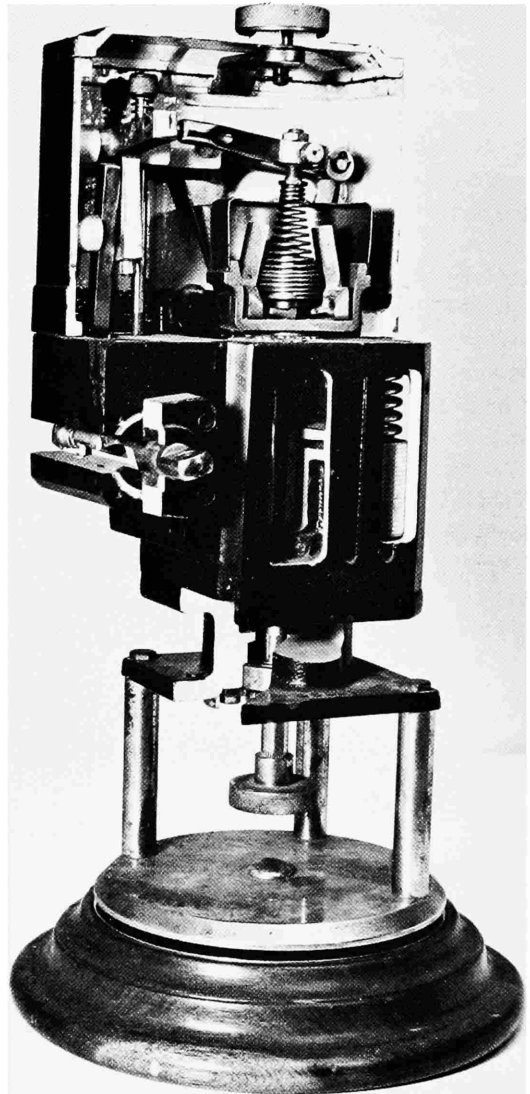

FIGURE 69.—Marquette "Model B117" engine governor with hydraulic servomotor, self-contained, 1940s. (NMHT 330028. Photo CLG.)

Products Co., Cleveland Ohio (NMHT 330028 Accession 288883; cutaway; $7\frac{3}{4}'' \times 6\frac{7}{8}'' \times 15\frac{1}{4}''$; on turntable, $7\frac{1}{2}''$ high). In its function as well as in its principles of design it is similar to the preceding Woodward Model "SI." Differences are only in details of construction.

A further development of this conception of prime-mover governor is the Woodward "Model UG8" dating from about 1950 (NMHT 315897; Accession 221844; cutaway; $5\frac{1}{4}'' \times 5\frac{3}{4}'' \times 12\frac{1}{2}''$; on display stand, $7\frac{1}{2}''$ high). It differs from the earlier Woodward unit by a more refined mechanical design, and by providing for several additional adjustments. A "compensating adjusting pointer" changes the proportional sensitivity;

a "load limit control" knob permits limit of the output to less than full stroke; the "speed droop control" knob permits elimination of the integral response, for a purely proportional response is preferable when several engines run on the same shaft or are paralleled in an electrical system.⁵⁸

58. Woodward Governor Company, *UG-8 Governor, Dial Control; Bulletin 03004 C* (Rockford, Illinois, no date).

CHAPTER 4

Friction Governors

Chronographs

A descendant of the classical steam governor, distinguished by extreme simplicity of conception, is the friction governor. Like its ancestor, it employs centrifugal flyweights to sense speed, but corrective action is taken simply by braking; it is usually driven by falling weights or wound-up springs. Such governors have been applied where constant speed is required for purposes related to time-keeping, as, for example, to propel recorder charts, to rotate the turn tables of phonographs and the beacons of light towers, and to turn equatorial telescopes synchronously with the rotation of the earth. The friction governor is also noteworthy for a historical reason. Early telescope regulators at Greenwich Observatory displayed some curious oscillatory phenomena which Astronomer Royal George Biddell Airy (1801–1892) felt challenged to investigate. His results, published in 1840 and 1850 in two frequently quoted papers, mark the beginnings of the theory of automatic control.⁵⁹

The oldest friction governor in the Museum's collection is part of the clockwork for an equatorial telescope, a 5-inch refractor by Troughton & Simms, which was acquired by the Georgetown College Observatory in 1849 (NMHT 316096; Accession 224215; brass, 6"×3½"×9"; unmarked). The gover-

nor (Figure 70), consisting of three pendulums suspended from a rotating triangular plate, is mounted on top of a rectangular box housing the gear train and the cable drum of the weight drive. A conical hood covers the governor. At overspeed, the centrifugal pendulums swing outward and press against the walls of the cover. The resulting friction leads to a reduction in speed. A more modern counterpart to this is the driving clock (Figure 71)

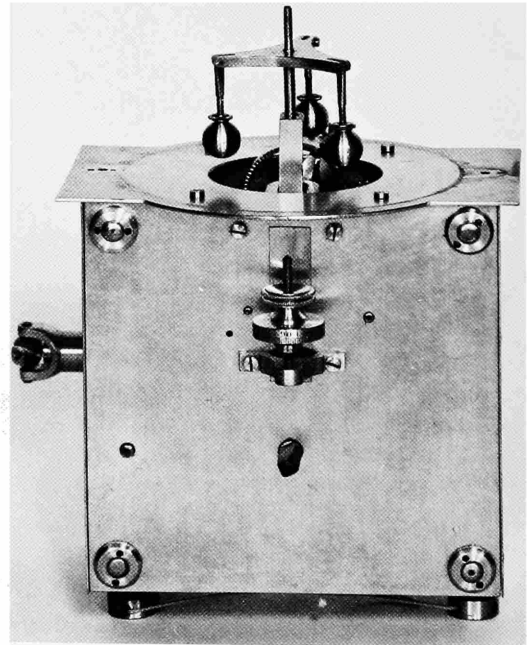

FIGURE 70.—Friction governor used on Troughton & Simms equatorial telescope of 1849. Not shown is the conical hood normally placed over the flyweights to provide a friction surface. (NMHT 316096. Smithsonian photo 71696.)

59. George Biddell Airy, "On the Regulator of the Clockwork for Effecting Uniform Motion of Equatorials," *Memoirs of the Royal Astronomical Society* 11 (1840):249–267; Supplement to the above, *Memoirs of the Royal Astronomical Society* 20 (1850):115–119.

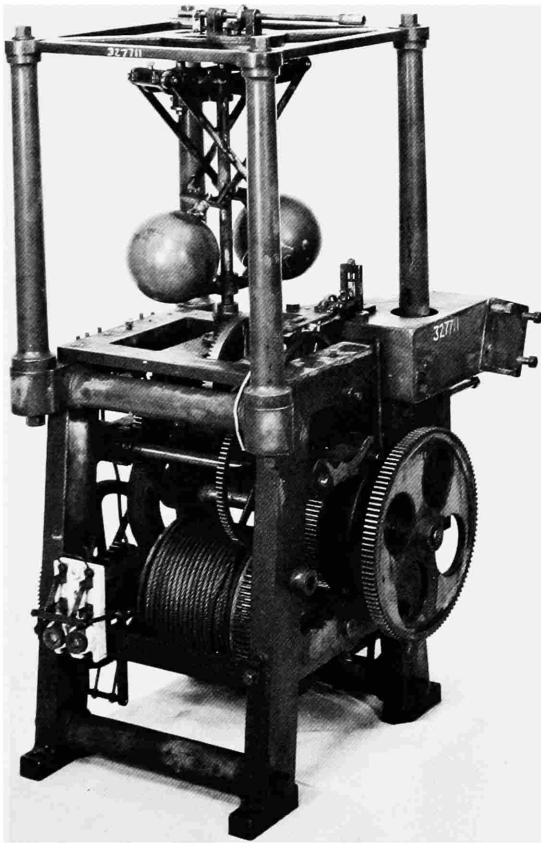

FIGURE 71.—Friction governor used to drive a large telescope at Princeton University, 1920s. (NMHT 327711. Smithsonian photo 70536.)

of the 23-inch refractor from the old Halsted Observatory, Princeton University, built in the 1920s by John W. Fecker of Pittsburgh (NMHT 327711; Accession 283654; steel, $21\frac{1}{2}'' \times 28'' \times 43''$; unmarked). It differs from the preceding one only in size. The governor consists of two flyballs of 5-inch diameter which at overspeeds actuate a large disk brake. Besides the gear train, a cable drum for the weight drive, and various provisions for adjustments, the rectangular frame of the clockwork houses a $\frac{1}{4}$ -hp electric motor for winding up the driving weight.

Chronographs, forerunners of the modern self-writing laboratory recorder, consisted of a paper-covered drum, rotating at a known constant speed which was usually maintained

by a centrifugal governor. The chronograph by the Washington instrument makers Fauth & Co. dates probably from the 1880s (NMHT 315243; Accession 217937; drum 14" long, mounted on iron base $12'' \times 22''$; unmarked). The two-arm friction governor is mounted above the weight-drive mechanism on one side of the drum. A similar but somewhat more recent chronograph (Figure 72), also probably by Fauth (NMHT 322455; Accession 248006; unmarked), is also weight-driven and equipped with a governor of the same design as the previous one.

Two detached clockworks, approximately from the turn of the century, offer no clue whether they were used on chronographs or on equatorials. The governor on the first (NMHT 328889; Accession 277637; brass; $7\frac{3}{4}'' \times 4\frac{1}{2}'' \times 9''$; unmarked) is of the same construction as those on the two above-mentioned Fauth chronographs. It is mounted on a rectangular gear box which contains neither a weight- nor a spring-drive. The other clockwork (NMHT 322282; Accession 250512; brass; $5\frac{1}{2}'' \times 3'' \times 11\frac{3}{4}''$; marked "G. Boulitte, Ing'r Const'r, 15 Rue Bobillet, Paris") is driven by a wound-up spring. It is regulated by a Pickering-type governor of three leaf springs, the lower collar of which presses at overspeed against a brake.

An interesting variation of the basic concept of the friction governor (Figure 73) is used on a Wiechert seismograph of about 1910 (NMHT 326987; Accession 265135; $34'' \times 34'' \times 52''$; marked "Spindler & Hoyer Göttingen"). The governor regulating the speed of its chronograph consists of two pendulum arms each carrying a flyweight as well as a metal vane. When these arms swing outward with rising speed, the corresponding increase in aerodynamic resistance provides the necessary braking effect, which on the previous governors was due to solid friction.

A chronograph of about 1940 (NMHT 316276; Accession 224564; marked "Elektrosignal G.m.b.H., Berlin 017, 220 Typ 05.5, Gerät 1+1") contains a spring-driven clockwork with a Pickering-type friction governor which is remarkable only for its extremely small size; it is approximately $\frac{3}{4}$ -inch long

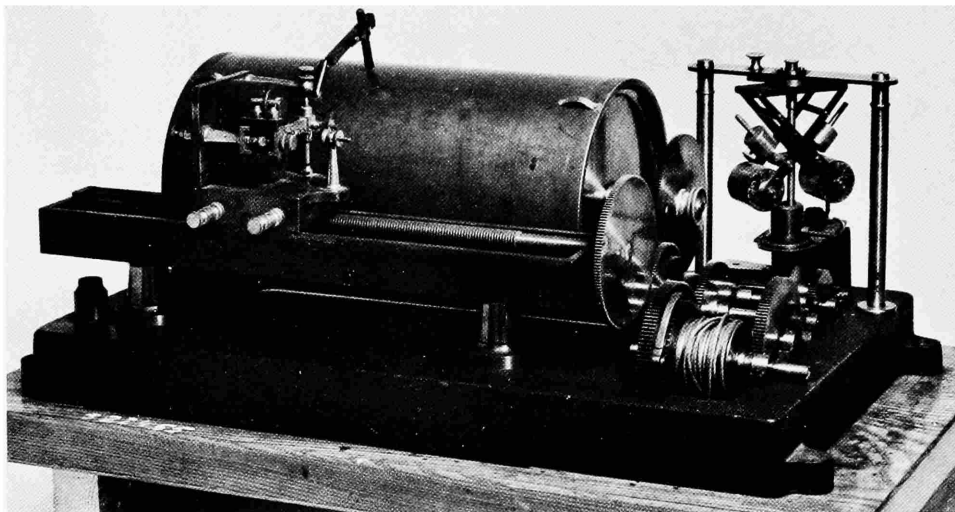

FIGURE 72.—Chronograph, probably by Fauth & Co., Washington, about 1890. (NMHT 322455. Smithsonian photo 71859.)

and $\frac{1}{2}$ -inch in diameter. The spring-driven clockwork invented in 1942 by C. G. Abbot, a former Secretary of the Smithsonian Institution (NMHT 314888; Accession 211900; brass; $6'' \times 5'' \times 5''$; unmarked; U.S. Patent 2367254), employs a spring-loaded friction governor in order to be able to run with equal accuracy in all orientations of its axis.

Phonographs

A new opportunity for friction governors presented itself with the introduction of the phonograph: the quality of tone reproduction depended on accurate speed control.⁶⁰ The Museum's collection contains more than one hundred phonographs and related devices, most of which are equipped with such governors.⁶¹ Instead of listing these all individually, we shall describe here only four repre-

60. Edward W. Kellogg, "A Review of the Quest for Constant Speed," *R.C.A. Review* 2 (1937):220-239.

61. For a detailed treatment of early phonographs, see James L. Andem, *A Practical Guide to the Use of the Edison Phonograph* (Cincinnati, 1892), especially pp. 17-21; Roland Gelatt, *The Fabulous Phonograph* (Philadelphia, 1955); Oliver Read and Walter L. Welch, *From Tinfoil to Stereo: Evolution of the Phonograph* (Indianapolis, 1959).

sentative specimens displayed in the Hall of Timekeeping and Light Machinery, where the governors are easily visible to the viewer. The

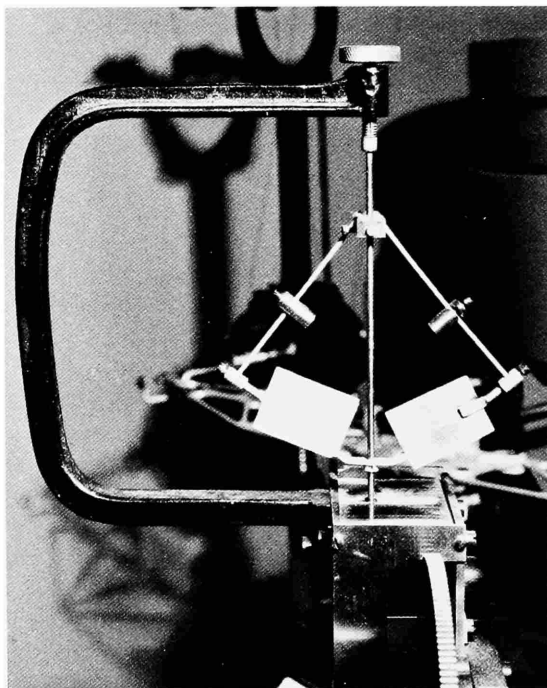

FIGURE 73.—Centrifugal vane governor on Wiechert seismograph, about 1910. (NMHT 326987. Smithsonian photo 72264.)

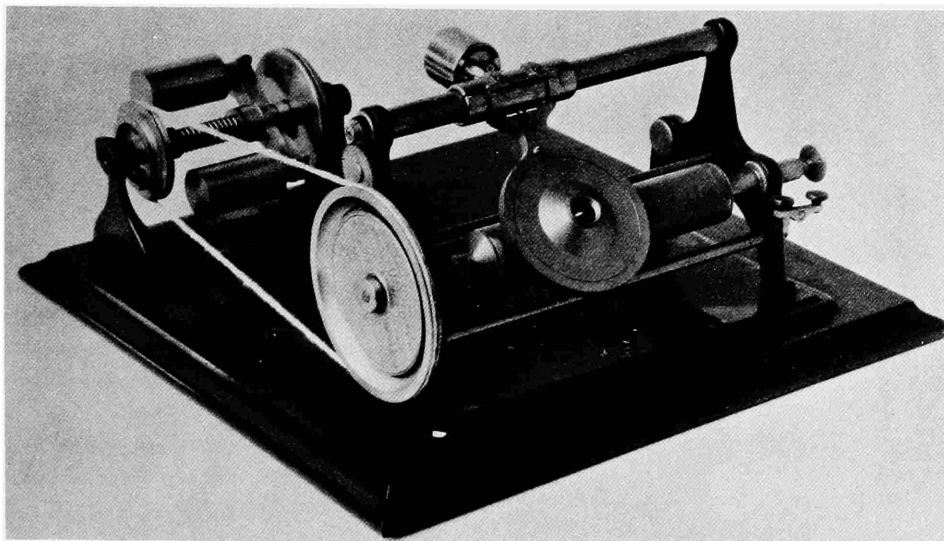

FIGURE 74.—Bell & Tainter "Type R" gramophone with friction governor (rear). (NMHT 1015. Smithsonian photo 42171-A.)

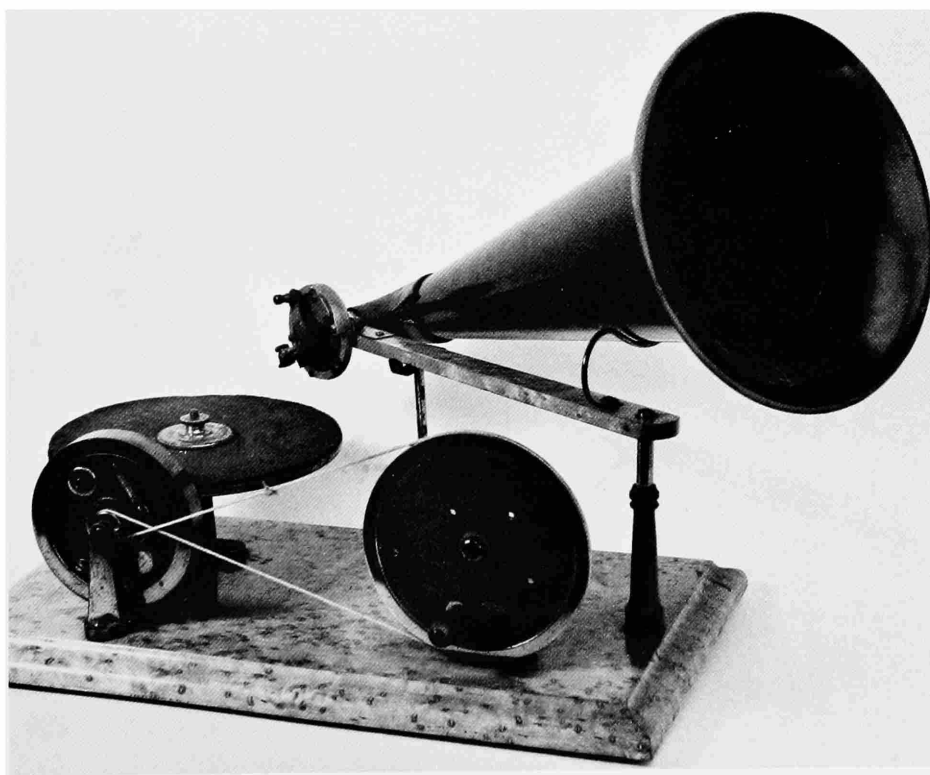

FIGURE 75.—Berliner gramophone equipped with governor (left) invented by Alfred C. Clark, 1898. (NMHT 253757. Smithsonian photo 42171-E.)

Bell & Tainter Graphophone (Figure 74) of 1887 (NMHT 1015; Accession 6139; built by the American Graphophone Co., Type B, old style; serial no. 04192) is equipped with a friction governor functioning in the same way as the chronograph governor described before. It is mounted separately from the recording and reproducing apparatus (marked "Patented July 20, 1886"; size $6\frac{1}{2}'' \times 10\frac{1}{2}'' \times 6''$).

Edison's successful phonograph of 1887 is represented by a specimen built about 1899 at Edison's shop especially for the Smithsonian Institution (NMHT 202871; Accession 35337). The electrically driven phonograph employs a small two-ball friction governor

modeled after Pickering's design. This arrangement was adopted in many phonographs, as, for example, in the coin-operated, spring-powered Graphophone "Model B" of the Columbia Phonograph Co., about 1897 (NMHT 314989; Accession 212922; serial no. 185552). The three-ball Pickering-type friction governor is visible through the glass cover in the rear of the machine.

The governor on Alfred C. Clark's patent model of an improved version of the Berliner Gramophone, 1898 (NMHT 253757; Accession 49940), is clearly derived from the steam engine shaft governor (Figure 75). In case of overspeed it separates the recording and reproducing mechanism from the hand drive.

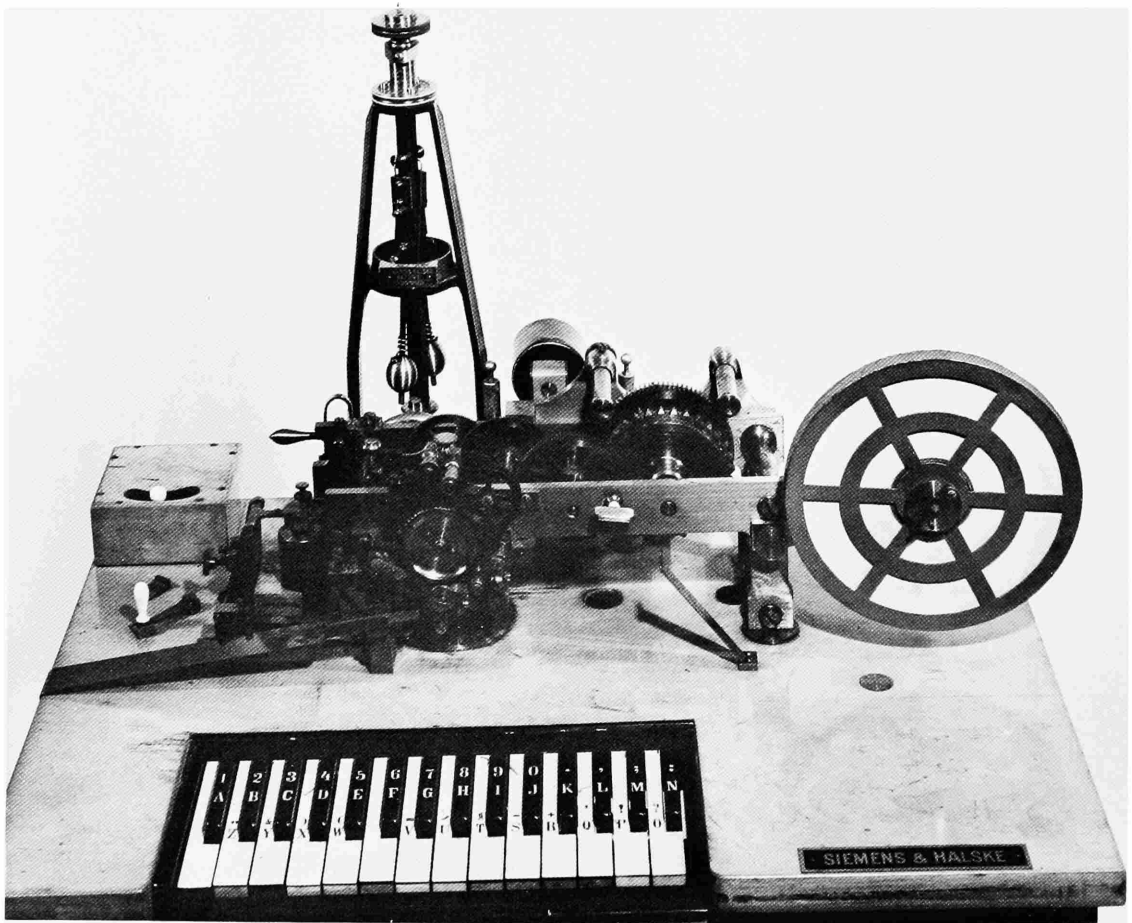

FIGURE 76.—Governor of Siemens & Halske printing telegraph, 1901. (NMHT 327954. Smithsonian photo 74616.)

Alfred C. Clark, of Berliner's retail store in Philadelphia, obtained for this governor the United States Patent 597875 of 25 January 1898.

Telegraphs

Governors were also used in certain systems of printing telegraphs based on synchronous rotation of corresponding parts at both the transmitter and the receiver. For example, the Hughes-type printing telegraph manufactured by Siemens & Halske employed a spring-loaded centrifugal friction governor (Figure 76). Our Museum has two specimens of this device (1. NMHT 319765; Accession 238390; about 1897; governor serial no. 1257. 2. NMHT 327954; Accession 271855; 1901; governor serial no. 3506).⁶²

Thomas A. Edison, for similar purposes, employed a simple, small centrifugal governor which at overspeed would break the battery connection to the electric motor driving the apparatus. Examples of this are the patent model (Figure 77) of his printing tele-



FIGURE 77.—Patent model of Thomas A. Edison's Gold and Stock printing telegraph, 1873. (NMHT 252616. Smithsonian photo 71882.)

graph (U.S. Patent 140488 of 1 July 1873; NMHT 252616; Accession 49064) and a patent model entitled "Telephonic Telegraph" (U.S. Patent 198087 of 11 December 1877; NMHT 252617; Accession 49064).

⁶² Theodor Karrass, *Geschichte der Telegraphie* (Braunschweig, 1909), pp. 294, 302.

Automatic Control of Steam Boilers

Since their earliest period steam boilers have provided opportunities of application for a variety of feedback devices. The oldest of these is the safety valve first described in 1681 by Denis Papin as a pressure regulator for pressure cookers but used by him as a steam boiler safety valve as early as 1707. It soon became an indispensable accessory of steam engines. Despite its simplicity—it consists of a weight-loaded valve in the boiler wall which is forced open by excessive steam pressure until the surplus steam is released—it represents a closed loop with negative feedback. Virtually all steam boilers in the Museum's collection, full-size specimens and scale models, possess safety valves. Since all are based on the same principle and show little historical development, these safety valves are too numerous to warrant individual listing. As a single representative of this class we

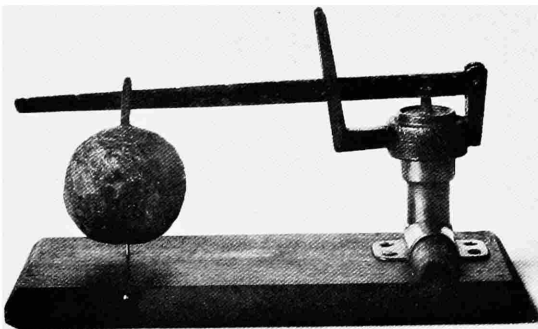

FIGURE 78.—Safety valve for water tube boiler by John Stevens, 1825. (NMHT 180029. Smithsonian photo 2720.)

may mention the safety valve (Figure 78) used by John Stevens on the water tube boiler of his experimental rack locomotive in 1825 (NMHT 180029; Accession 20760).⁶³ It is a simple disk valve held closed by a spherical lead weight suspended from the end of a pivoted lever. The desired boiler pressure can be adjusted by sliding the weight inward or outward along the lever.

In the middle of the eighteenth century another feedback device was added to the boiler. The float valve, employed to keep the water level in the boiler automatically constant, was first described in a patent of James Brindley of 1758 (English Patent 730); toward the end of the century this invention was widely accepted.⁶⁴ Unfortunately this invention is represented in the collections of the Museum by only a single device, the float level regulator of the Shipman "Automatic" steam engine.⁶⁵

A little later, feedback devices were applied to regulate the steam pressure by adjusting the rate of combustion. The arrangements proposed usually consisted of a pressure-sensing device linked to a damper in the chimney, reducing the draft in case of excessive steam pressure. Matthew Murray of Leeds, England, patented such a system in 1799 (English Patent 2327); a similar one was

63. Taylor, *Catalogue of Mechanical Collections*, pp. 109–110, 119.

64. Mayr, *Origins of Feedback Control*, pp. 76–81.

65. For typical examples of level control on steam boilers, see George F. Gebhardt, *Steam Power Plant Engineering*, 5th ed. (New York, 1917), pp. 640–644; and Terrell Croft, *Steam Power Plant Auxiliaries and Accessories* (New York, 1922), pp. 203–204.

employed by Boulton & Watt about 1803;⁶⁶ more recent ones are described by Gebhardt.⁶⁷ In other cases the rate of combustion was

66. H. W. Dickinson and Rhys Jenkins, *James Watt and the Steam Engine* (Oxford, 1927), p. 239.

67. Gebhardt, *Steam Power Plant Engineering*, pp. 178-179.

controlled not by varying the draft but by changing the rate of fuel input directly.

Both these types of boiler control, a float valve level regulator and a steam pressure control system, are represented on the Shipman "Automatic Steam Engine" (Figure 79) built about 1885 by the Shipman Engine

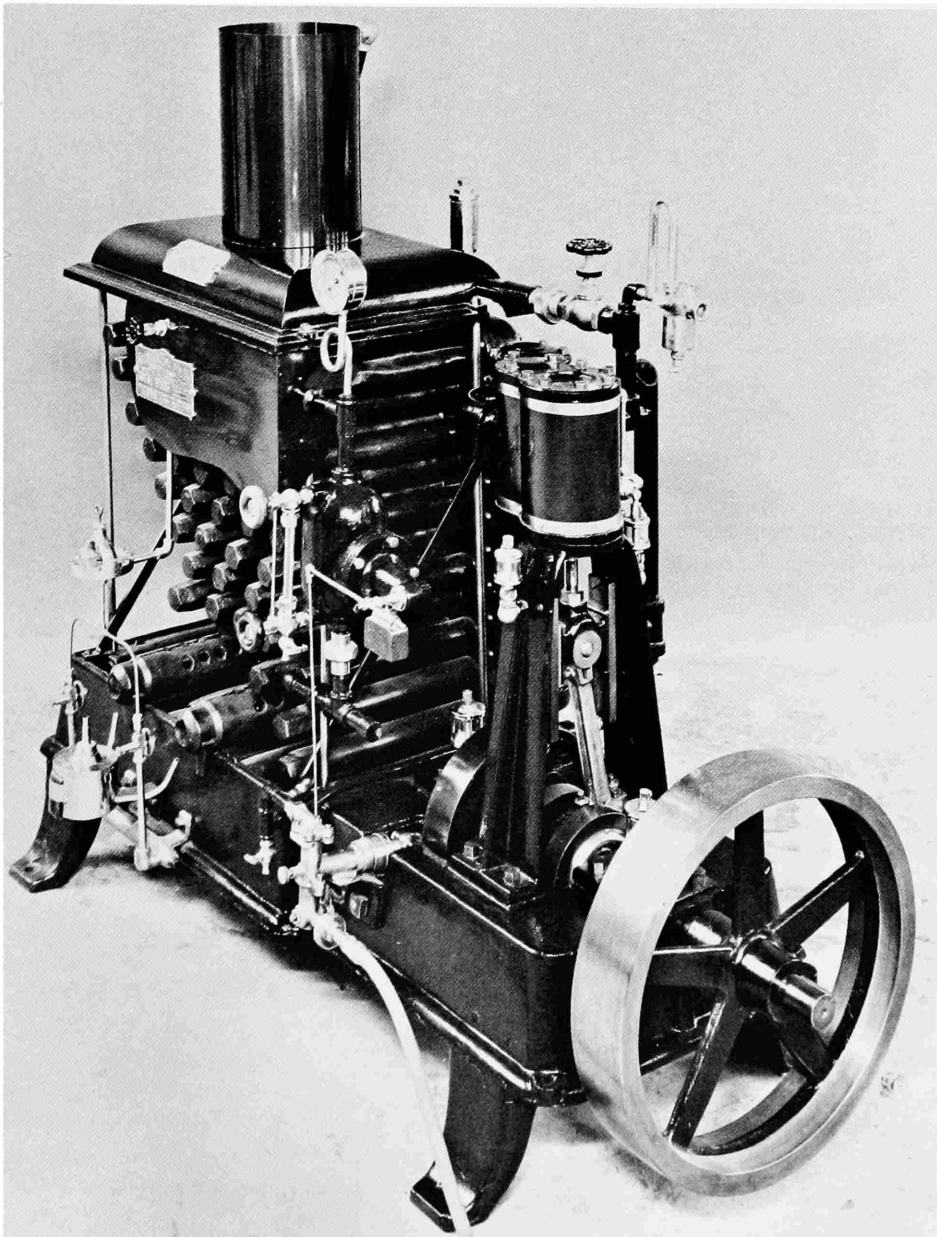

FIGURE 79.—Shipman "Automatic Steam Engine," about 1885.
(NMHT 315712. Smithsonian photo 45572.)

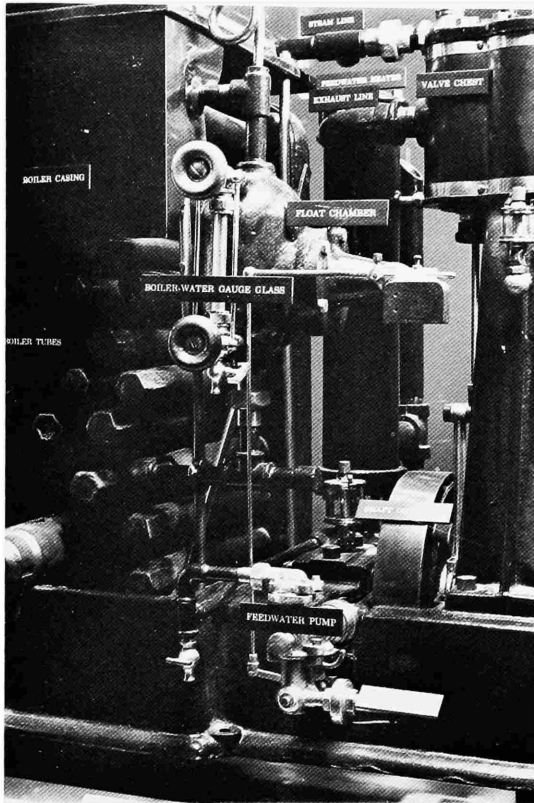

FIGURE 80.—Shipman "Automatic Steam Engine," detail view of level control system and shaft governor. (Photo CLG.)

Manufacturing Co. of Rochester, N.Y., and Boston (NMHT 315712; Accession 221209; Boston Model No. 2-1081; 2 hp at 400 r.p.m.; size of unit 20"×45"×34"). Boiler and steam engine are integrated into a compact self-contained unit. Designed to operate automatically without need of supervision, it served successfully as a prime mover in a variety of workshops and small factories. Apart from the shaft governor on the steam engine and the obligatory safety valve, it has automatic control systems for the supply of feedwater and fuel oil. The water level in the boiler is measured by a pivoted float in the chamber near the center of the machine (Figure 80). The float is connected by linkages to a valve in the waterline to the feed pump. When it

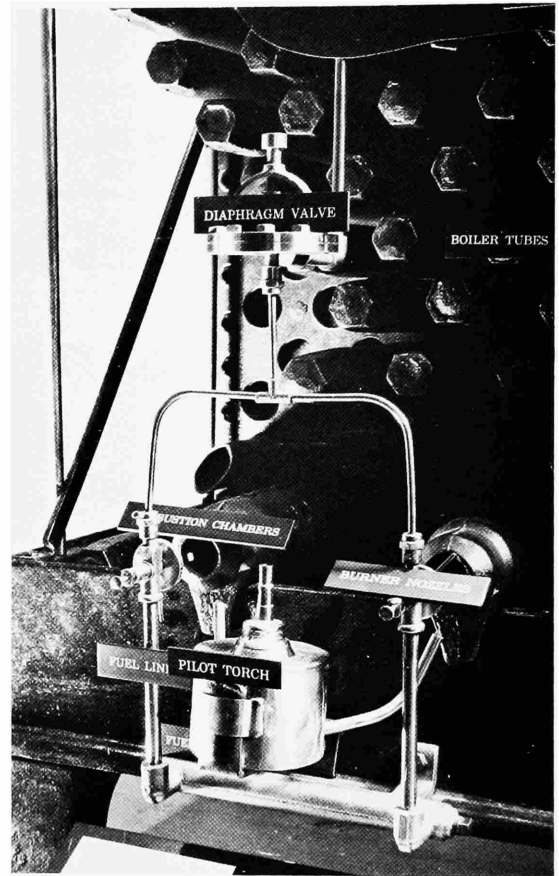

FIGURE 81.—Shipman "Automatic Steam Engine," detail view of steam pressure control system. (Photo CLG.)

rises it will reduce the feedwater supply, and vice versa. The steam pressure is regulated by varying the rate of fuel input (Figure 81). The steam header at the top of the boiler is directly connected to a spring-loaded diaphragm which actuates a valve in the fuel-oil line. In normal operation this valve is open, and kerosene flows freely to the two burners. If the steam pressure rises, the fuel flow is throttled until the steam pressure sinks. When fuel resumes flowing again, proper ignition is assured by pilot flames. Both systems can be regarded as simplified examples of equivalent but more refined systems in use on larger steam boilers.

Pressure Regulators

A great variety of feedback devices are used to maintain constant pressure in distribution lines of steam, gas, air, or water. The Museum's collections contain several early pressure regulators and reducing valves. The oldest of these is a patent model (Figures 82 and 83) of Charles E. Lloyd dating from 1854 (U.S. Patent 11128 of 20 June 1854) describing a combined gas meter and regulator (NMHT

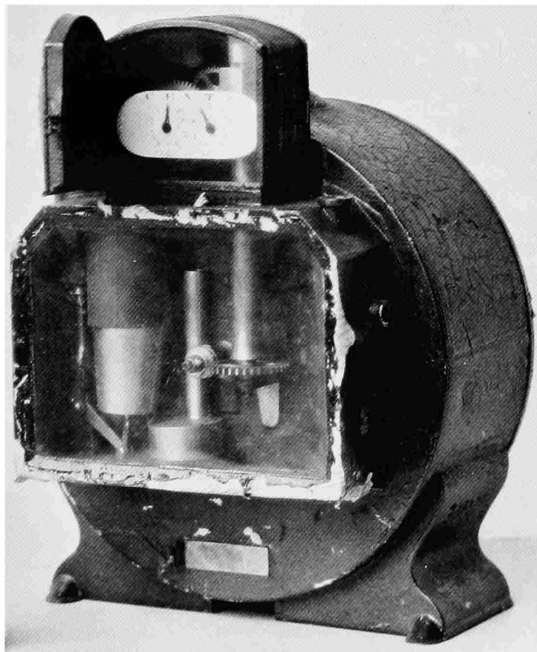

FIGURE 82.—Patent model of gas meter with pressure regulator by C. C. Lloyd, 1854. (NMHT 309279. Smithsonian photo 616-G.)

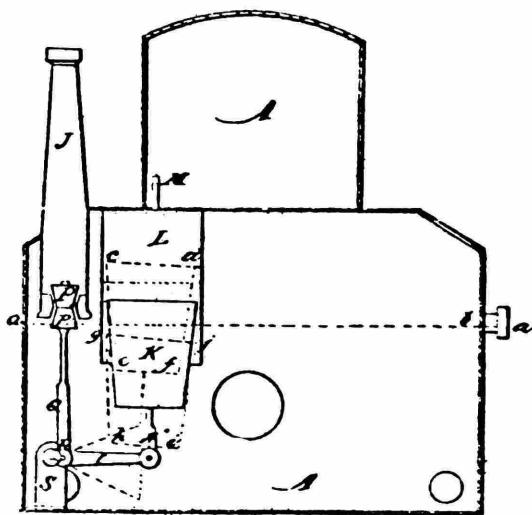

FIGURE 83.—Schematic diagram of Lloyd's pressure regulator. Reprinted from *U.S. Patent No. 11128 of June 20, 1854, Patent Specifications, fig. 2.*

309279; Accession 89797; brass and tin, $7\frac{1}{2}'' \times 10\frac{1}{2}'' \times 13''$). As a gas meter, the device is of conventional design. It employs a large paddle wheel rotating in proportion to the volume of gas consumed where the count of revolutions provides the basis for billing. Like other gas meters of that period, it is partly filled with water; thus the bearings of the paddle wheel are sealed, to prevent gas leaks, and lubricated at the same time. The patented invention combines two features. Apart from shutting off the gas (to avoid dangerous leaks) when the water level is too low, it maintains a constant gas pressure in the line of the consumer. This removes an important source of uncertainty from the billing procedure, for the meter registers only volume without rec-

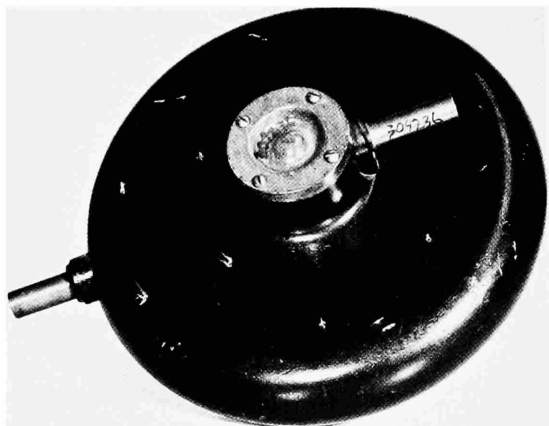

FIGURE 84.—Patent model of steam pressure regulator by George H. Corliss, 1869. (NMHT 309236. Photo CLG.)

ognizing that the value of gas increases with its pressure. The device for sensing pressure (Figure 83) is similar to an arrangement used on pressure regulators for steam boilers, for example by Boulton & Watt in 1803.⁶⁸ It consists of a float swimming in a vertical pipe, the lower end of the pipe is submerged, while the upper end is vented to atmosphere. Since the water level in the gas meter outside of this cylinder is exposed to the gas, the level in the pipe will rise with increasing gas pressure. The float, in turn, is linked to a double cone valve in the gas intake line, which is of such shape that it will seal both in its high

68. Dickinson and Jenkins, *James Watt and Steam Engine*, p. 239, pls. 40, 90.

and in its low position, opening the line at positions between the extremes. Consequently, the flow of gas will be shut off both when the float rises too high due to excessive pressure, and when it sinks too low due to the absence of water.

An 1869 patent model of a steam pressure regulator (Figures 84 and 85) is the work of George H. Corliss (U.S. Patent 85566 of 5 January 1869; NMHT 309236; Accession 89797; wood model with brass valve parts; 8½" diam., 3½" high).⁶⁹ This regulator was intended to serve as a reducing valve in steam-heating plants. It consists basically of a flat, circular chamber with elastic sides that will bulge outward under internal pressure. Placed in the center of one wall is a valve the cone of which is connected to the opposite wall in such fashion that the valve will close at the expansion of the chamber, and open at its contraction. The chamber is connected with the steam line to be regulated, while the upstream side of the valve is facing the high-pressure steam supply. When the controlled steam pressure falls below the desired value, the elastic chamber contracts, opening the valve and admitting steam until the desired pressure is restored.

A more advanced stage of development is displayed in the gas pressure regulator of A. Kipp and H. Murphy, represented by a patent model (Figure 86) for the U.S. Patent 224190 of 3 February 1880 (NMHT 308713; Accession

69. Taylor, *Catalogue of Mechanical Collections*, p. 75.

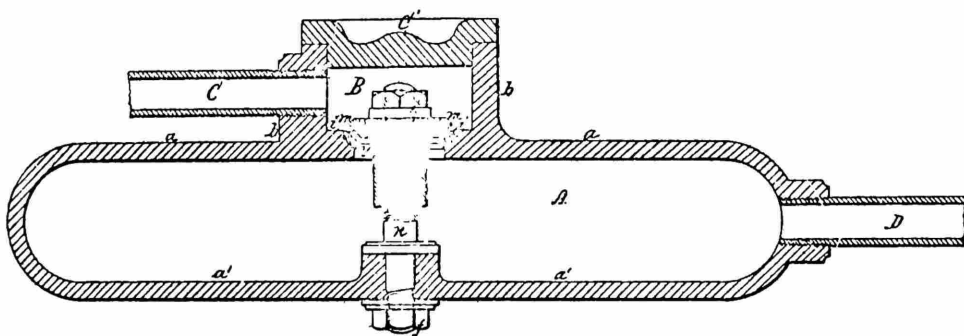

FIGURE 85.—Cross-section drawing of Corliss's pressure regulator. Reprinted from *U.S. Patent No. 85566 of Jan. 5, 1869, Patent Specifications*.

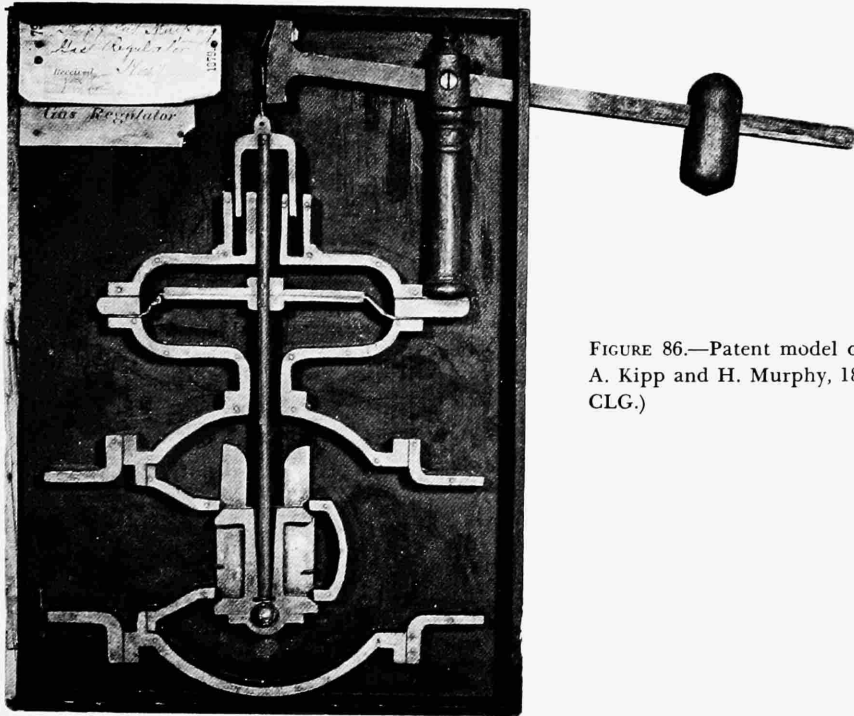

FIGURE 86.—Patent model of gas pressure regulator by A. Kipp and H. Murphy, 1880. (NMHT 308713. Photo CLG.)

89797; two-dimensional schematic model, wood, $8\frac{1}{2}'' \times 12''$). In contrast to Corliss's design, the functions of measuring and regulating are here fully separated. Mounted above a conventional double-seat poppet valve is a flat, circular chamber containing a diaphragm attached to the valve stem. The space below the diaphragm is connected with the downstream side of the valve, that is, the pressure to be controlled, while the upper side is vented. The weight of the valve stem is balanced by a counterweight arranged on a lever above the unit. The regulator works similarly to that of Corliss. If the controlled pressure is at the desired value, the force on the diaphragm will be great enough to close the valve; if the pressure sinks, the valve will be opened, admitting the required quantity of gas.

A somewhat exotic variation on this basic theme is the regulator on a water-driven air ejector used to maintain the vacuum in the

return line of a steam-heating system (Figure 87). The device dates from about 1910 and was built by the Hancock Inspirator Co. ex-

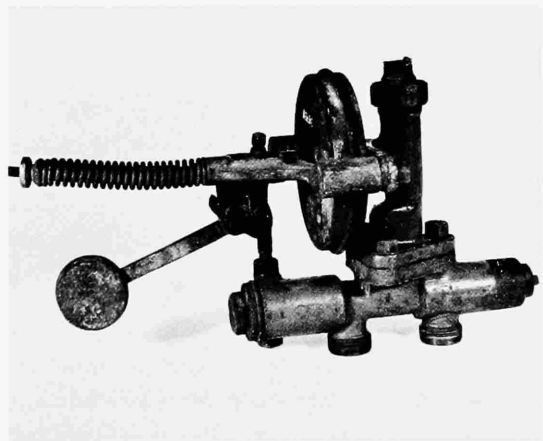

FIGURE 87.—Hancock-Cryer vacuum regulator used in steam heating, about 1910. (NMHT 315438. Photo CLG.)

clusively for the T. B. Cryer Company, Newark, N. J. (NMHT 315438; Accession 216348; unmarked and severely corroded, cast iron, 8"×10"×16"). The regulator is mounted on a conventional air ejector energized by water. A set of circular spring-loaded bellows connected to the vacuum line expands or contracts according to the measure of the

vacuum. By suitable linkages this motion is transmitted to a valve that apparently controls the water supply to the ejector.

A number of contemporary reducing valves, found in the Museum in various functions and places, have not been cataloged. Generally, these perform like the Kipp-Murphy regulator.

Temperature Control

The first known temperature regulator was invented about 1620 by Cornelis Drebbel (1572–1633), a Dutch engineer in the service of King James I of Britain. To maintain constant temperatures in chemical furnaces and in incubators (Figure 88), he connected a thermoscope with a damper so that it would, at excessive temperatures, reduce the oxygen supply to the fire.⁷⁰ During the following centuries the invention evolved gradually. Bimetallic rods came into use as temperature-sensing elements in the late eighteenth century; in 1830 Andrew Ure introduced the term “thermostat.” At the end of the nineteenth century, thermostats were found in numerous industrial applications.⁷¹ The collections of the National Museum of History and Technology hold only a few examples of thermostats that can be called historic.

Starting at the end of the last century, the Honeywell Heating Specialities Co. had developed a system of automatic temperature control for home central-heating plants. The Museum has a set of the main components of such a system (Figure 89), dating from the early 1920s. The system was very versatile; it could be adapted to most furnaces regardless of whether they burned coal, oil, or gas; and whether the heating medium was air, water, or steam. The present system was probably employed on a coal-burning hot-water plant. It consists of three devices: a room thermo-

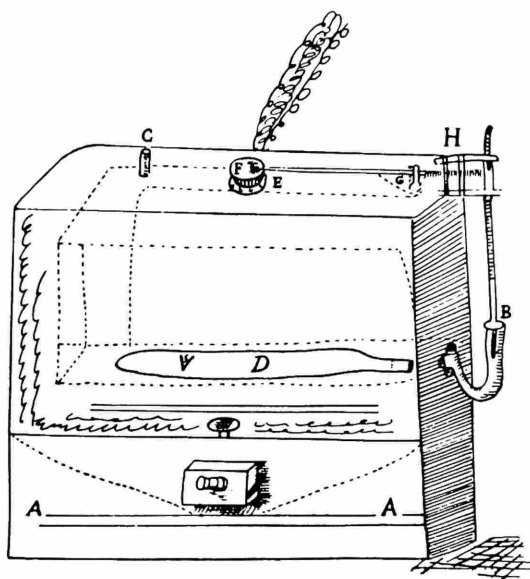

FIGURE 88.—Cornelis Drebbel's chicken incubator with temperature regulation, about 1620. Reprinted with permission of the Cambridge University Library from MS 2206, part 5, fol. 218.

stat (NMHT 316657), a spring regulator motor (NMHT 316656), and an “Aquistat” (NMHT 316658; Accession 226965 for all three). The system operates electrically on the power of a 12-volt dry-cell battery. The room thermostat (“Honeywell Model 4. Plain Pattern”) consists of a spiral-shaped bimetal strip which tends to straighten with rising temperature, and whose outer tip is free to move between two closely spaced electrical contact points. Depending on the ambient temperature, this free tip touches one of the two contacts, closing a circuit to turn on the

70. F. M. Gibbs, “The Furnaces and Thermometers of Cornelis Drebbel,” *Annals of Science* 6(1948):32–43.

71. A. R. J. Ramsey, “The Thermostat or Heat Governor: An Outline of its History,” *Transactions of the Newcomen Society* 25 (1945–47):53–72.

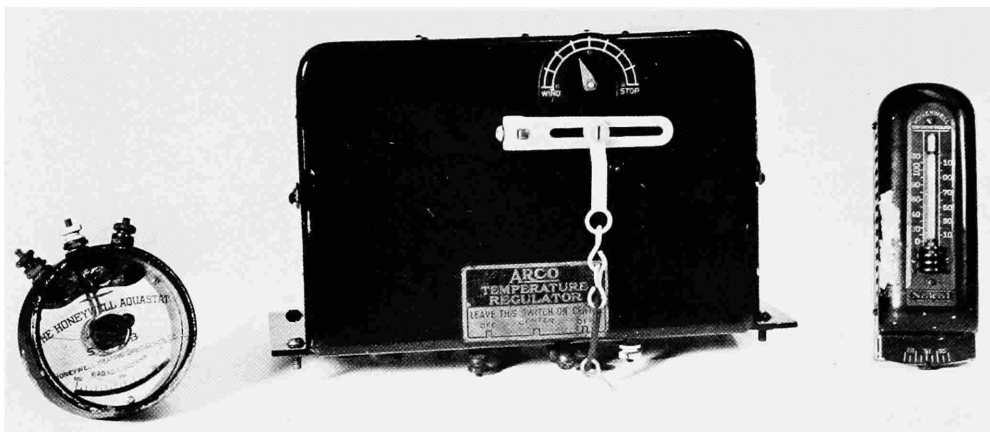

FIGURE 89.—Honeywell home temperature control system, about 1920. From left to right: "Aquastat"; spring motor for actuating damper; room thermostat. (NMHT 316658, 316656, 316657. Photo CLG.)

furnace when more heat is required, or turning off the furnace when the temperature is too high. The desired temperature can be adjusted from 50° to 90° F along a calibrated scale by changing the starting position of the bimetal strip.

The spring motor (NMHT 316656), marked "Arco Temperature Regulator" but identical with a unit marketed by Honeywell, converts electrical signals from the thermostat into an action affecting the fire in the furnace. The signals energize a solenoid which releases a spring motor, opening or closing both the fresh air and the flue dampers of the furnace. Since the dampers cannot be held in any intermediate positions, the system provides merely on-off control. The motor is driven by a powerful spring which has to be rewound every one to two weeks. A pointer indicates the state of unwinding of the spring.

The third unit of the system, a Honeywell Style B Aquastat (NMHT 316658), is in essence also a bimetallic thermostat. Installed

in the line of hot water leaving the furnace, it is wired to override the command from the room thermostat whenever the water temperature exceeds a certain maximum value.

Another important field of application for thermostats is in the temperature control of furnaces and ovens. A representative of this group is an electric vacuum oven (Type *Weber*, sold by the Arthur H. Thomas Co.) of about 1930 (NMHT 326619; Accession 261654; serial no. IBS 26396; overall size 16"×15"×30"). The thermostat is mounted on the top of the oven; its principle of operation is similar to that of the Honeywell room thermostat, except that it acts upon electrical heating elements. The desired temperature can be set at values between 20° and 150° F. The thermostat is marked "Type VAC; Serial No. 3573; Volts 115 DC; Amps 8; U.S. Patent No. 1594481, Aug. 3, 1926."⁷²

72. Arthur H. Thomas Company, *Laboratory Apparatus and Reagents*, 1931 edition (Philadelphia, 1931), p. 608.

Feedback Control on Textile Machinery

In the collection of the Museum's Division of Textiles we found four machines employing feedback. Three of these are let-off mechanisms for power looms, the fourth is a regulator for cotton drawing frames.

After the introduction of the power loom the problem of inventing satisfactory take-up and let-off motions received the attention of a great many inventors. The purpose of a let-off mechanism is this: on power looms, the warp is commonly drawn through the machine at constant speed. For a product of high quality, it is important that the tension of the fabric is constant during the process of weaving, which is made difficult because the diameter of the yarn beam, on which

the unwoven yarn is coiled, diminishes as the yarn is "let off." Of the countless patented mechanisms for letting off yarn in such a way that constant tension is maintained while the speed of rotation of the yarn beam changes, only a few employ the principle of feedback. On these, the tension is measured directly by a spring-loaded roller pressing against the warp: the distance by which the warp is deflected from its normal course by the roller is assumed to be inversely proportional to the tension. The yarn beam's speed of rotation is then automatically adjusted according to this measurement. At high tension the speed is increased, at low tension, reduced. The take-up motion is, as the term implies,

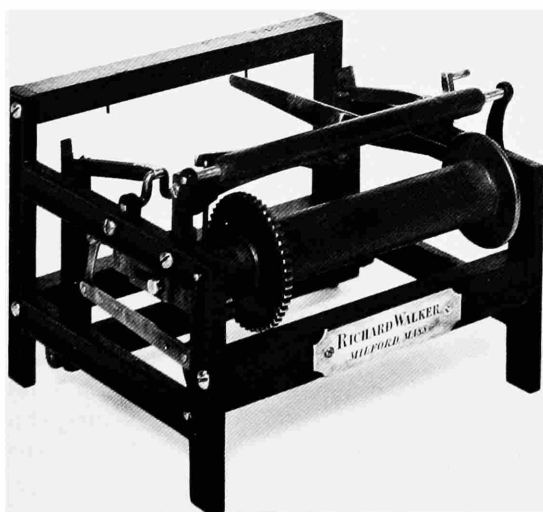

FIGURE 90.—Patent model of let-off mechanism for power looms by Richard Walker, 1867. (NMHT T-11412. Smithsonian photo 71296.)

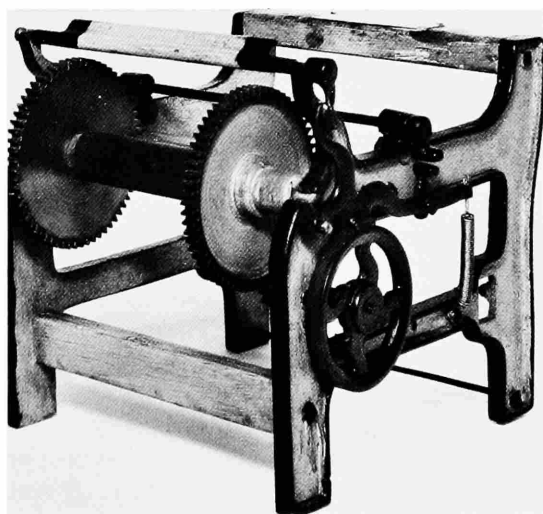

FIGURE 91.—Patent model of let-off mechanism for power looms by George Richardson, 1867. (NMHT T-11411. Smithsonian photo 71298.)

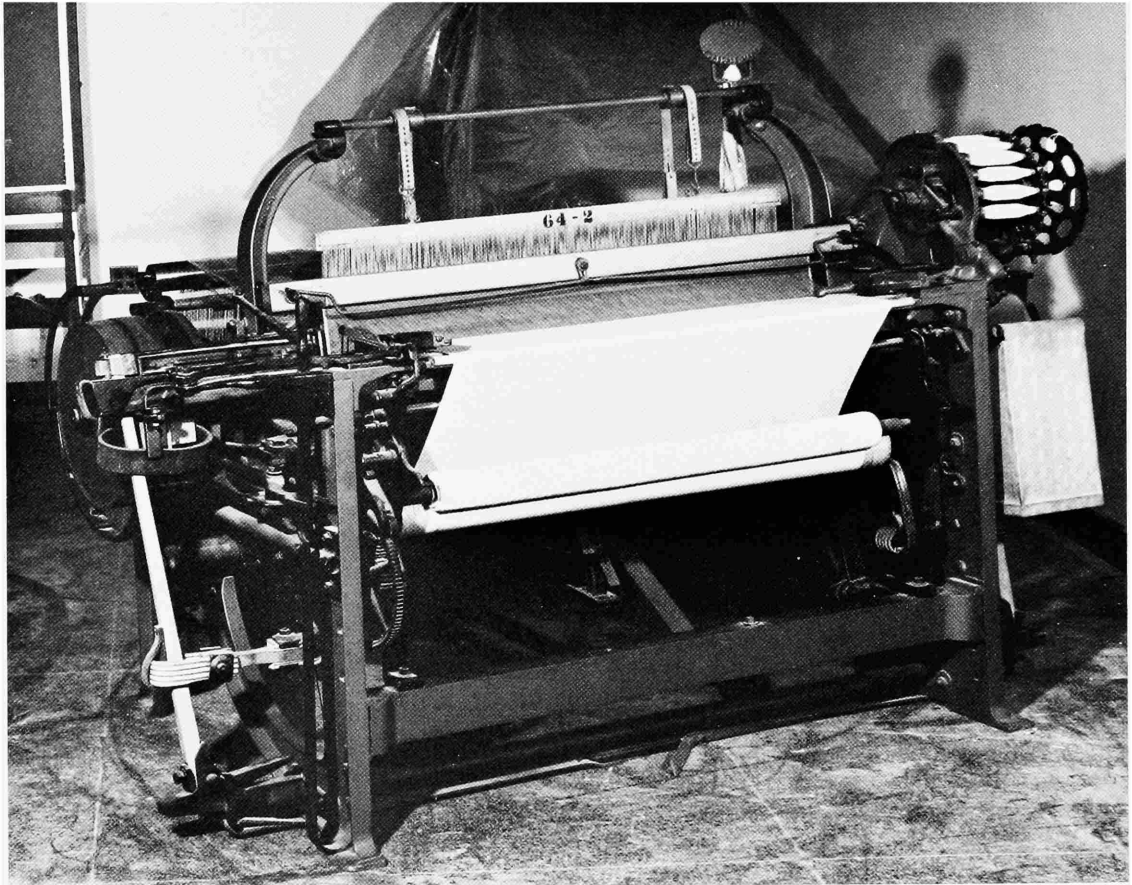

FIGURE 92.—Draper "Model A Northrop" power loom, 1895, equipped with "Bartlett" let-off mechanism (not visible). (NMHT T-8571. Smithsonian photo 71299.)

the opposite of the let-off motion; the machinery employed is very similar in both cases.

The oldest of our let-off mechanisms for power looms is a patent model (Figure 90) by Richard Walker of Milford, Massachusetts, for the U.S. Patent 62168 on 19 February 1867 (NMHT T-11412; Accession 89797; mostly wood, $6\frac{1}{2}'' \times 7\frac{1}{2}'' \times 5''$). The rotation of the yarn beam is here controlled by an escapement-like mechanism employing a double ratchet, powered by the oscillatory motion of the lay sword of the loom. A tension-sensing bar pressing against the warp determines whether the lay sword during its work stroke will actually engage the escapement. In the case of low tension the mechanical train will be interrupted, arresting

the escapement until the tension in the warp has risen back to the desired level.

In the patent model (Figure 91) by George Richardson of Lowell, Massachusetts (U.S. Patent 64147 of 23 April 1867), the same purpose is achieved quite differently (NMHT T-11411; Accession 89797; cast iron and wood, $11'' \times 9'' \times 9''$). Here the yarn beam is retarded by a simple brake. The sensing beam pressing against the warp will release this brake whenever the tension exceeds the proper level.

A third let-off mechanism is represented not by a patent model but by a full-scale power loom used in actual production (Figure 92). The feature that made the "Northrop Loom" of the Draper Company in

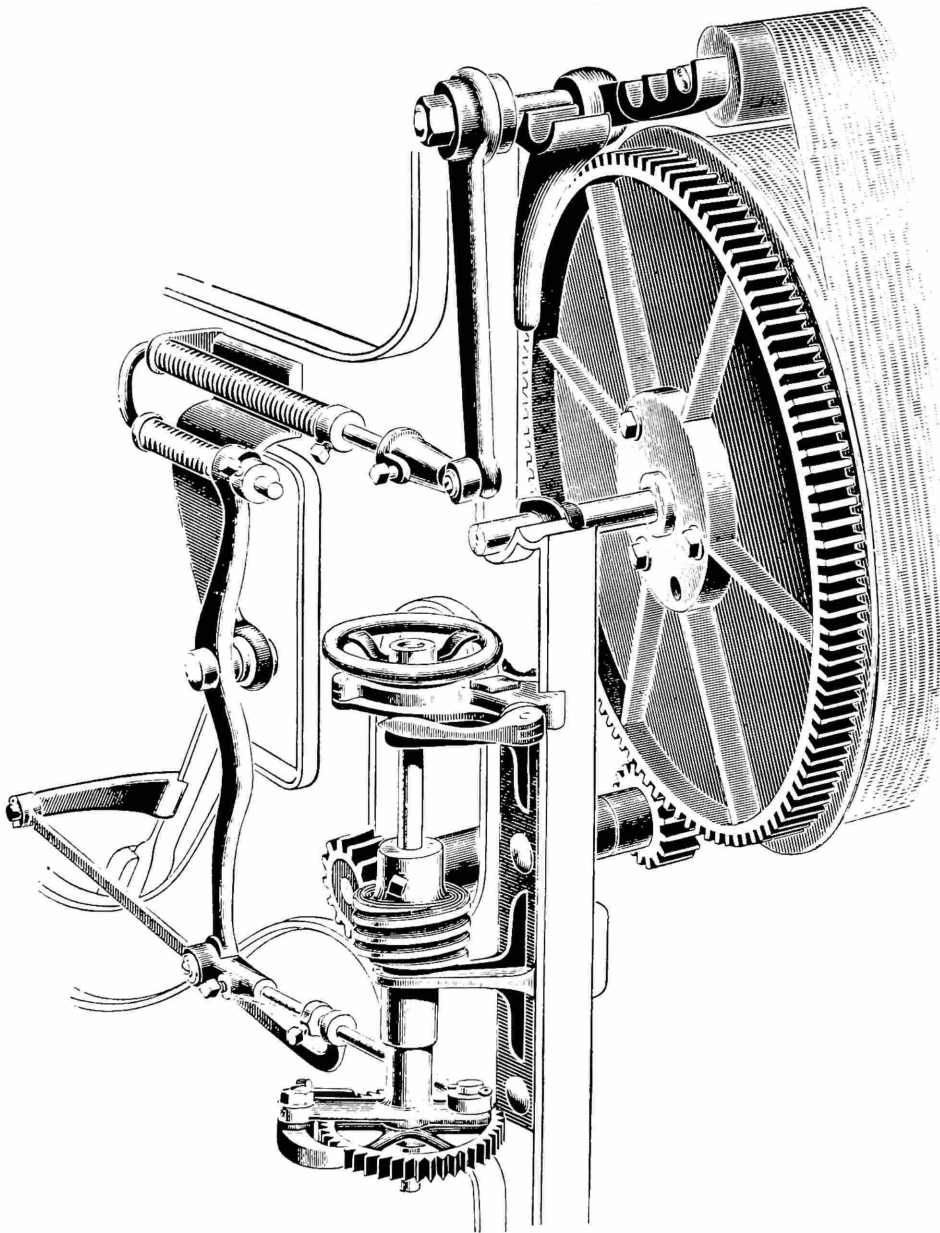

FIGURE 93.—The "Bartlett" let-off mechanism as used on NMHT T-8571. Reprinted from The Draper Co., *Labor Saving Looms*, 2nd edition (Hopedale, Massachusetts, 1905), p. 93.

Hopedale, Massachusetts, famous is the automatic shuttle-bobbin changer. In our Museum this loom is represented by a "Model A" unit built in 1895, the year the invention was introduced (NMHT T-8571; Accession 160340). The let-off mechanism on

this loom (Figure 93) is of an older, established design, known as the "Bartlett Let-Off," invented by D. W. Snell and S. S. Bartlett (U.S. Patent 16405; 13 January 1857). In principle it resembles the let-off motion of R. Walker (Figure 90). The yarn

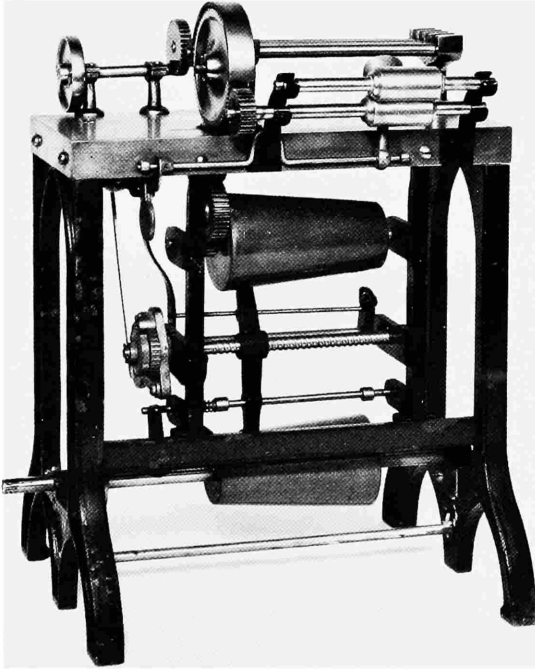

FIGURE 94.—Patent model of regulator for drawing-frames by Samuel J. Whitton, 1869. (NMHT T-11421. Smithsonian photo 71297.)

beam, through appropriate gearing, is rotated by a ratchet drive powered by the continuously oscillating lay sword. The length of stroke of the ratchet motion, however, is variable; it is controlled by the tension-sensing device which is—as before—a spring-loaded beam pressing against the warp. If the tension is high, the stroke of the ratchet is shortened, and vice versa.⁷³

⁷³ George Draper, "Let-Off Motion for Looms," *Proceedings, New England Cotton Manufacturers' Association* 8 (1870):22-27; The Draper Company, *Textile Texts for Cotton Manufacturers* (Hopedale, Massachusetts, 1901); The Draper Company, *Labor-Saving Looms*, 2nd edition (Hopedale, Massachusetts, 1905), pp. 94-96, 151-152.

A very different kind of feedback device is the patent model of a regulator for drawing frames (Figure 94) invented in 1869 by Samuel J. Whitton (U.S. Patent 86719 of 9 February 1869; NMHT T-11421; Accession 89797; an exceptionally well-made model of cast iron and steel; size 9"×6½"×12"). In cotton spinning, generally, the actual process of spinning is preceded by that of "drawing." The cotton sliver, a fluffy strand of cotton, untwisted yet and therefore of little tensile strength, passes consecutively through two sets of friction rollers, of which the second one advances at a higher speed than the first, so that the sliver becomes longer and thinner. The purpose of the present invention is to regulate the thickness of the resulting sliver. The thickness is measured by a trumpet-shaped funnel located between the two sets of friction rollers. The funnel is mounted at the end of a pivoted lever held in position by a counterweight. On its way through the process, the sliver is fed through the funnel; if it is thin, it will pass without disturbing the funnel; if it is thick, it will push the funnel back by a distance depending on the thickness of the sliver. While the first set of friction rollers rotates at constant speed, the second one is driven through a variable-speed transmission (consisting of two parallel, opposite cone drums connected by an endless belt which can be shifted sideways), of which the ratio is controlled by the thickness-sensing device. The second pair of friction rollers, then, will be accelerated with increasing thickness. It will draw the cotton sliver more strongly lengthwise, thus making it thinner. If the cotton sliver becomes too thin, the process is reversed.

Feedback Control on Land Vehicles

Railway Technology

In the Museum's collections of land vehicles, the search for feedback devices has proved more fruitful among the automobiles than in the railroad technology. Apart from

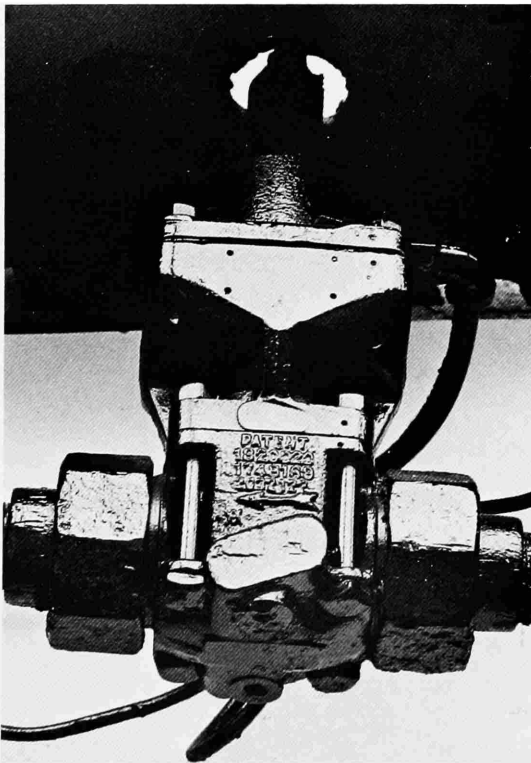

FIGURE 95.—Westinghouse air pressure regulator for pneumatic braking system; installed on Southern Railway Locomotive No. 1401, 1926. (NMHT 320000. Photo CLG.)

safety valves, which, as stated earlier, are not to be cataloged because of their simplicity as well as overabundance, the only feedback device discovered in railroad equipment is a Westinghouse air-pump regulator (“Type AD. Single Top”) which is part of the pneumatic brake system on the large passenger locomotive of 1926 (NMHT 320000; Accession 196330; Southern Railway Locomotive No. 1401; built by the American Locomotive Co., Richmond, construction no. 66888). The pressure regulator (Figure 95) consists of a spring-loaded diaphragm mounted on a throttle valve in the steam line on the left side of the engine, above the middle drive wheel, directly to the right of the compressor. It maintains a constant supply pressure for the air-brake system by manipulating the steam flow rate to the steam-driven air compressor feeding the system.

Steam Automobiles

On automobiles, in contrast, feedback devices appear in great diversity, ranging from the various controls on the boilers of early steam cars, through speed governors, thermostats, pressure regulators, and voltage regulators, to power steering. Many of these devices were adopted from other fields. Some early steam automobiles, for example, employed automatic controls resembling those on previous stationary steam engines. The steam pressure regulator of the “Locomobile” steam automobile of 1900 (NMHT 309639; Accession 106490; “Style 2” of the Locomobile Company of America, Bridgeport,

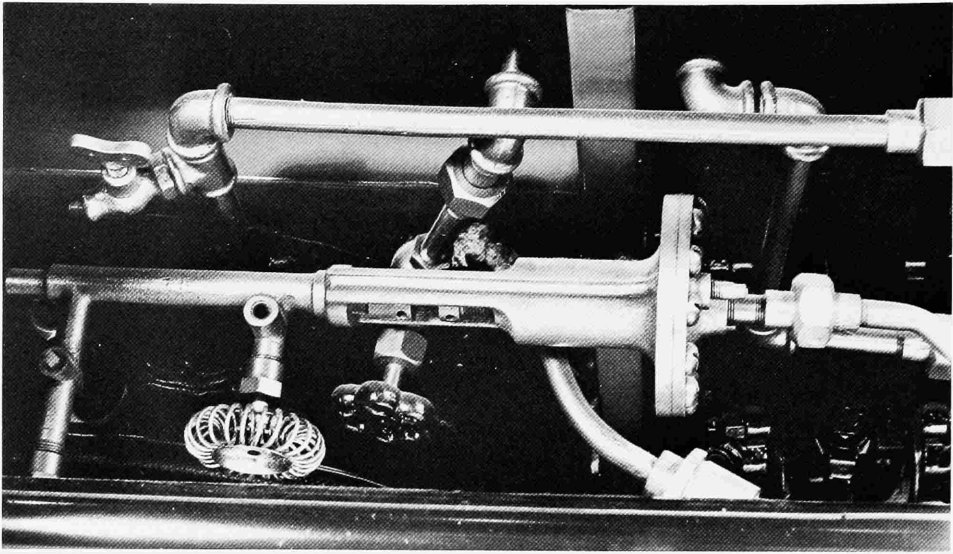

FIGURE 96.—Steam pressure regulator on “Locomobile” steam automobile, 1900. Upward view under the right side of the car, in front of right rear wheel. (NMHT 309639. Photo CLG.)

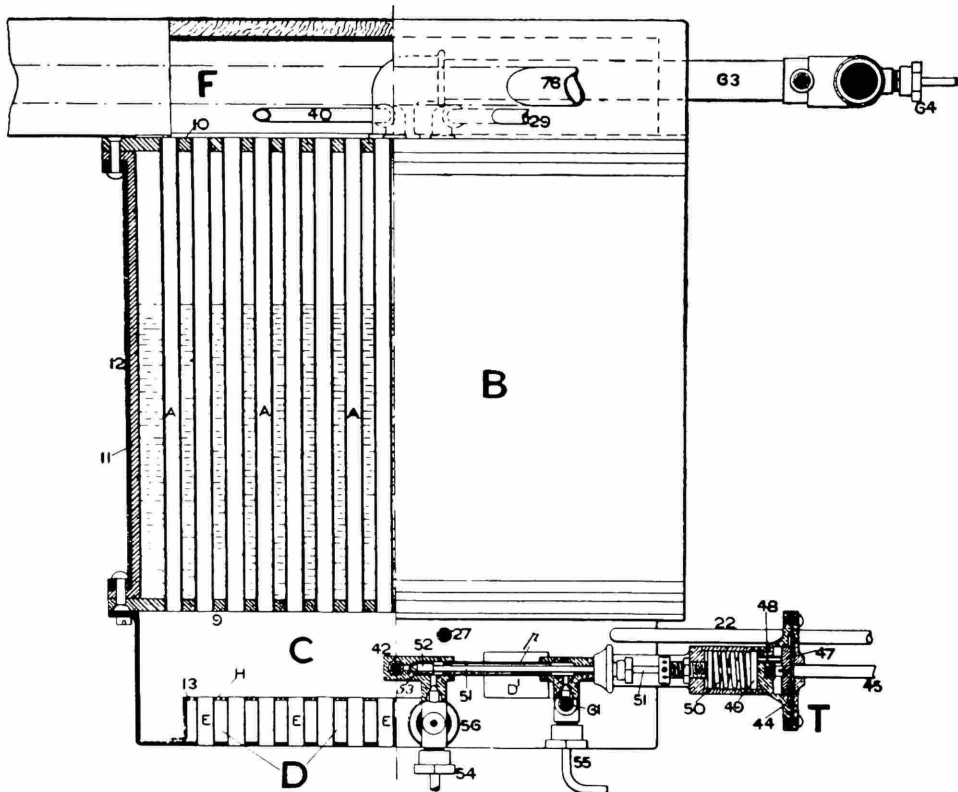

FIGURE 97.—“Locomobile” steam automobile. Side elevation drawing of steam boiler and pressure regulator (T). Reprinted from W. Worby Beaumont, *Motor Vehicles and Motors* (Westminster, 1900), p. 461.

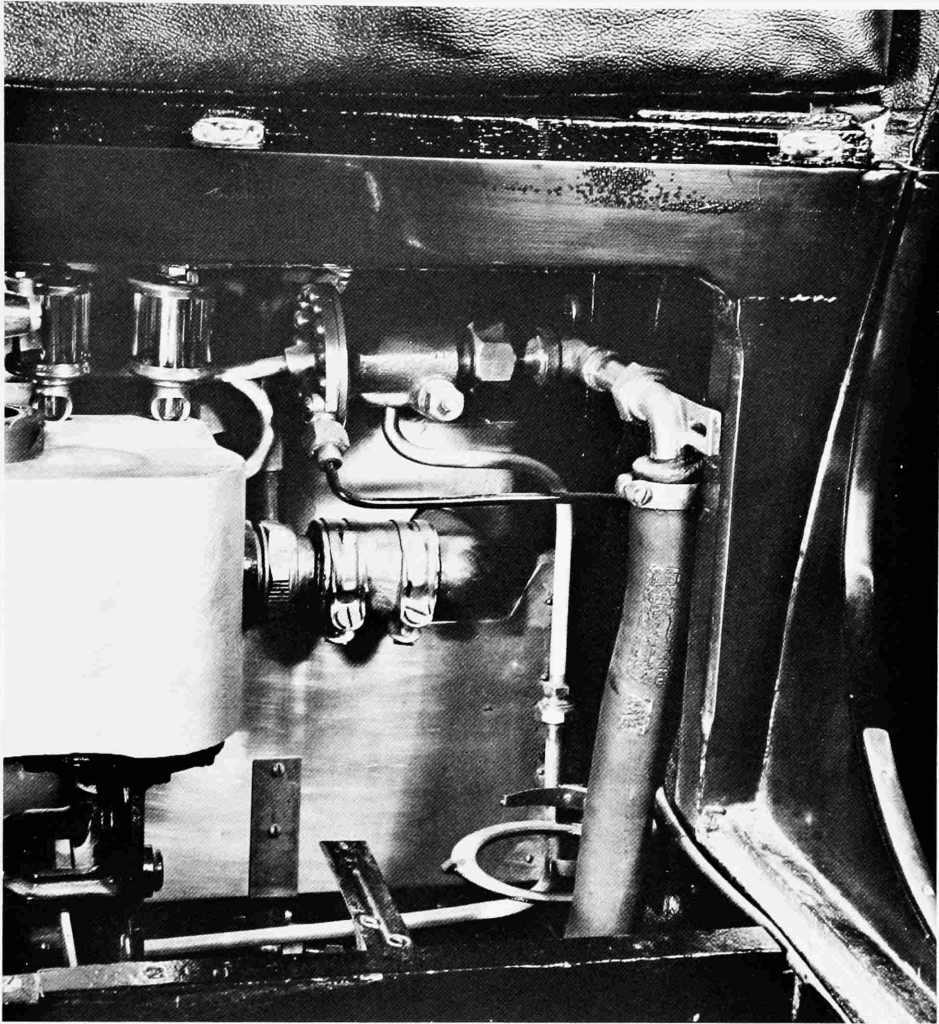

FIGURE 98.—Steam pressure regulator of White steam automobile, 1902; view under the left seat showing the diaphragm throttling valve (center). (NMHT 309497. Photo CLG.)

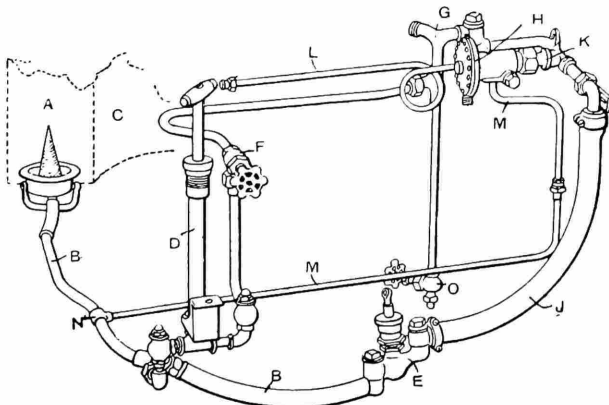

FIGURE 99.—White steam automobile: water supply circuit and steam pressure control system. Pressure sensing diaphragm (H); throttle valve (K); steam connection (L); water supply (B-J); water line to boiler (G). Reprinted from Paul N. Hasluck (ed.), *The Automobile*, 2nd edition (London, 1903), p. 573.

Conn.; serial no. 2795)⁷⁴ operates on the same principle as that on the older "Shipman Automatic" steam engine, described above (Figure 81). It is located (Figures 96 and 97) in front of the boiler, under the right passenger seat, and consists of a spring-loaded diaphragm actuating a throttle valve in the fuel line to the burner. The diaphragm is exposed to boiler pressure. In case of rising pressure it will reduce the rate of combustion, and vice versa. Not regulated automatically, however, is the supply of feedwater. Instead, a sight glass is provided, by means of which the driver monitors the boiler level in order to make the necessary adjustments manually.⁷⁵ The vehicle's name, "Locomotive," incidentally, is misleading: the car's design is identical with that of the better known "Stanley Steamer"; the car was renamed after the Stanley brothers' original firm changed hands in 1899.

Similar, but somewhat more refined, are the controls (Figures 98–101) on the White steam automobile of 1902 (NMHT 309497; Accession 101849; built by the White Sewing Machine Company of Cleveland; serial no. 260).⁷⁶ Here both the pressure and the exit temperature of the steam are regulated automatically. The pressure regulator consists of a diaphragm throttle valve (located under the left seat, Figure 98) similar to that of the Locomobile, except that it adjusts the flow rate of feedwater instead of fuel (Figure 99). The water level of the boiler, therefore, no longer requires the driver's attention. In a second feedback loop, a constant temperature of the steam is maintained by a thermostat (Figure 100). It consists of a bimetal temperature-sensing element *J* immersed in the slightly superheated steam at the boiler exit, which actuates a needle valve (below *K*) in the fuel line to the burners. This valve will be closed with rising, and opened with falling, steam temperatures. The thermostat is

found underneath the car, slightly in front of the right rear wheel (Figure 101). Since both the steam pressure and the flow rate of the fuel are regulated automatically, the driver controls the vehicle's speed by adjusting the flow rate of steam to the cylinders.⁷⁷

Speed Governors on Trucks and Tractors

Another class of control devices adopted from an older technology were the speed governors. They had no purpose of course on passenger cars, where the driver cherishes the power of determining the speed himself. On trucks and tractors, however, they served an important function. In the era of cobblestone roads, solid rubber tires, and stiff springs, the only way to protect the vehicle from continuous exposure to the most severe shocks was to drastically limit its speed. Speed governors disappeared gradually during the 1920s, when trucks began to be equipped with pneumatic tires. The arrangement of such governors was usually simple. They were geared to the engine and manipulated the throttle valve in the gas intake pipe. Sometimes an adjustment was provided for changing speeds. Truck governors were usually set and sealed at the factory for top speeds between 10 and 20 miles per hour, depending on the size of the vehicle.

Our Museum has two tractors and two trucks with such speed control. The "Waterloo Boy" tractor of 1918 (first tractor marketed by the John Deere Co., Model N; NMHT 67A2; Accession 270864) is equipped with a simple centrifugal governor mounted conspicuously on top of the engine block and acting on the throttle. The governor is spring loaded; the controlled speed can be varied manually from the driver's seat by changing the initial compression of the spring. Similarly equipped is the Avery Bulldog Tractor of 1919 (NMHT 58A6; Accession 222860). Here the governor is arranged less visibly under the hood, between radiator and engine

74. S. H. Oliver and D. H. Berkebile, *The Smithsonian Collection of Automobiles and Motorcycles* (Washington, D.C., 1968), pp. 49–51.

75. William Worby Beaumont, *Motor Vehicles and Motors* (Westminster, 1900), pp. 462–463.

76. Oliver and Berkebile, *Smithsonian Collection of Automobiles*, pp. 61–63.

77. Paul N. Hasluck (ed.), *The Automobile*, 2nd edition (London, 1903), pp. 72–74, 569–572.

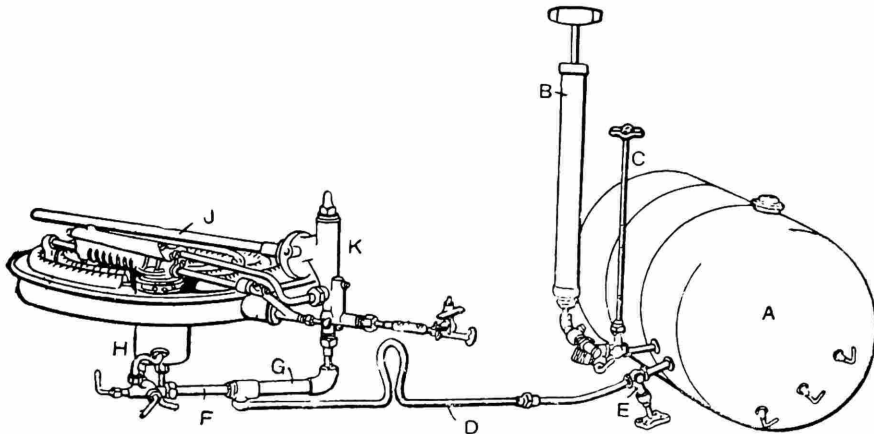

FIGURE 100.—White steam automobile: fuel connections, gasoline burner and thermostat (J-K). Reprinted from Paul N. Hasluck (ed.), *The Automobile*, 2nd edition (London, 1903), p. 572.

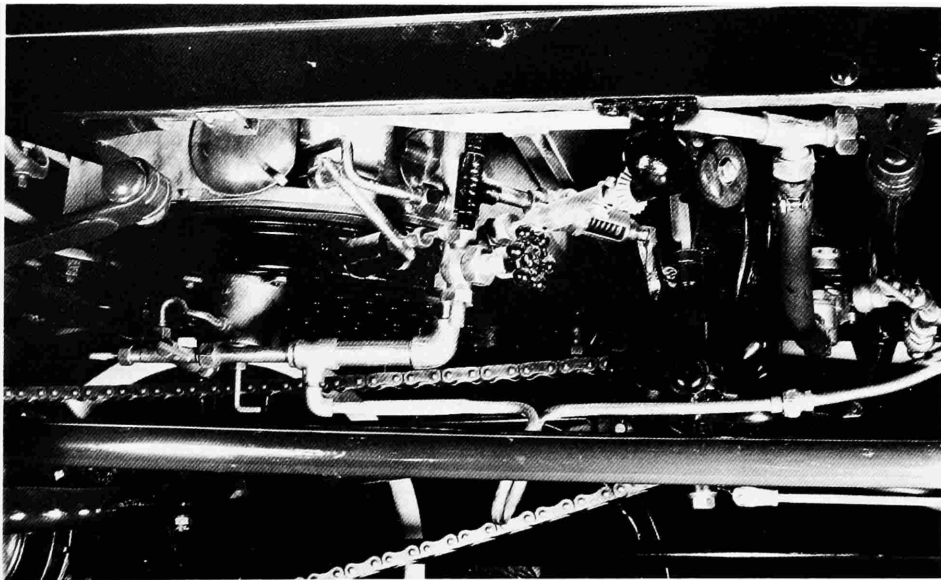

FIGURE 101.—White steam automobile: view under the car in front of right rear wheel, showing bottom of boiler and parts of the thermostat (center). (Photo CLG.)

block. The Autocar Heavy Duty engine of 1921, a 28.9-hp, four-cylinder gasoline engine was used to drive the heavy Model 26 Autocar trucks (NMHT 307254, engine only; Accession 68520; cutaway for display purposes). It is equipped with a hydraulic governor manufactured by the Pharo Mfg. Co., Detroit, Michigan (patented 17 April 1917). The governor consists of a centrifugal pump impeller in a closed oil-filled capsule bounded on one side by a movable spring-

loaded baffle. The pump impeller is geared to the engine. With rising speed it displaces the baffle which actuates a throttle valve in the gas intake line. An adjusting screw for the spring tension—i.e., the desired speed—is factory sealed. Even the Mack “Bulldog” truck of 1930 still carries a governor (NMHT 322560; Accession 251010; model “AC,” 7 tons, 156” wheelbase).⁷⁸ The conventional

⁷⁸ Oliver and Berkebile, *Smithsonian Collection of Automobiles*, p. 150.

centrifugal governor, located at the front of the engine block directly to the upper left of the starter crank, is totally enclosed against tampering. It was set for a top speed of 18 miles per hour.

Automobile Thermostats

It was early recognized to be advantageous if the cooling water surrounding the cylinders could be kept at a constant optimum temperature despite changes in vehicle speed, load, and ambient air temperature. On many early cars this was done manually by the driver who watched a cooling water thermometer and accordingly adjusted by dampers the airflow through the radiator. Several thermostatic arrangements were proposed to perform this function automatically. The advantage advertised for such systems was a substantial saving in fuel. One of the first mass-produced automobiles to employ this innovation was the eight-cylinder Cadillac, introduced in 1915, and equipped with cooling water thermostats in 1917. The Museum has the chassis of a later model of this car, a "Model 61" of 1923 (NMHT 308218; Accession 71005).⁷⁹ The thermostat employed here works on the same principle as many designs of today (Figure 102). It consists simply of a cylindrical capsule with accordion-shaped walls, partly filled with a special liquid chosen for a boiling point coinciding with the desired water temperature. The capsule actuates a throttle valve in the cooling water circuit. When the water temperature is below the desired value, the capsule contracts, restricting the circulation of cooling water until the temperature rises to the proper level. At higher temperatures the capsule expands, freeing the water passage, thus increasing the cooling action. The 1923 Cadillac has separate cooling circuits for the two halves of its V-8 engine. The thermostats are installed on each side in front of the respective water pumps, located between the radiator and the bottom of the engine block.⁸⁰

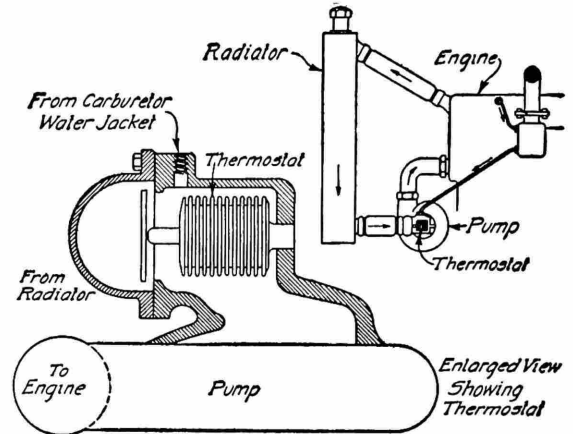

FIGURE 102.—Cooling water thermostat as installed in 1923 "Model 61" Cadillac. Reprinted, with permission, from The American Technical Society, *Automobile Engineering*, 6 vols. (Chicago, 1921), vol. 1, p. 293.

For many years an alternate type of cooling water thermostat was in use. The thermostat proper similarly consisted of a liquid-filled capsule submerged in the hot water return line from the engine. Instead of manipulating the cooling water flow, however, it controlled the flow of cooling air by adjusting a row of shutters in front of the radiator. Upon falling water temperature the shutters would close, restricting the flow of cooling air, until the water temperature had returned to the proper level. Our Museum has no specimens of automobiles equipped with this type of temperature control, but an adequate substitute is perhaps the Packard "Winterfront" from the 1920s. This is a detachable radiator grille with thermostatically controlled shutters (Figure 103) designed to be clamped in front of automobile radiators during the cold season (NMHT 329286; Accession 281784; marked "PACKARD MOTOR CAR CO. WINTERFRONT" and "PINES AUTOMATIC WINTERFRONT PATENTED OCT. 20, 1914; APRIL 11, 1916; JUNE 8, 1920; OCT. 11, 1921. MADE IN U.S.A. OTHER PATENTS PENDING"). The liquid-filled bellows, located at the top center, is mechanically linked to move the shutters. Because the capsule is not in direct contact with the water, it had to be clamped tightly

79. *Ibid.*, pp. 143–145.

80. American Technical Society, *Automobile Engineering*, 6 vols. (Chicago, 1921), I:439–440.



FIGURE 103.—Packard “Winterfront,” 1920s: view from front and back. The shutters are operated by a thermostat (top center) which senses the radiator temperature through metal contact. (NMHT 329286. Smithsonian photos 71537, back, and 71538, front.)

against the radiator to sense the cooling water temperature by heat conduction.

Thermostatic shutters eventually went out of use, leaving the field to thermostats directly installed in the cooling water circuit. A more recent witness to this, in our collections, is the ¼-ton Bantam Army truck of 1940, an experimental forerunner of the “Jeep” (NMHT 312822; Accession 167398). The thermostat, similar to that on the 1923 Cadillac, is installed in the water outlet elbow of the cooling water circuit.⁸¹

Float-Feed Carburetors

Virtually all contemporary automobile carburetors employ, in many different forms, a simple and ancient feedback device, the float valve: a float connected with a needle valve in the fuel line, with the function of maintaining a constant level of gasoline in the supply chamber of the carburetor. The

first float-feed carburetor was invented in 1893 by Wilhelm Maybach, Daimler’s collaborator, who was doubtless unaware that a similar float valve had been employed in the water clock of Ktesibios of Alexandria in the third century B.C.⁸²

It is neither possible nor worthwhile to list here all float-feed carburetors in the Museum’s collections; instead we mention as a single representative that of A. L. Dyke of 1900 (Figure 104), reportedly the first American-made float-feed carburetor publicly marketed (NMHT 308479; Accession 87038; marked “A. O. DYKE MNFG’R.”).⁸³ It consists mainly of the float chamber (marked) and the mixing chamber (showing the air intake opening). The lever arrangement above is the external part of the throttle valve by which the engine speed is controlled. The gasoline enters the float chamber at the top; after flowing through the needle valve, it is sprayed into an upward stream of air. Then the combustible mixture passes through

81. *War Department Technical Manual, TM9-803: 1/4-Ton 4x4 Truck* (Washington, D.C., 1944), pp. 105, 143.

82. Beaumont, *Motor Vehicles and Motors*, p. 71.

83. Taylor, *Catalogue of Mechanical Collections*, p. 169.

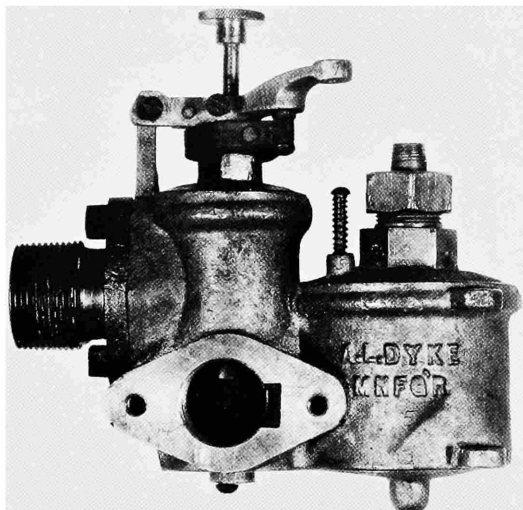

FIGURE 104.—A. L. Dyke float-feed carburetor, 1900. (NMHT 308479. Smithsonian photo 18494-C.)

the mixing chamber and the throttle, before it is drawn into the intake manifold of the engine.

Many carburetors, incidentally, are equipped with automatic adjustments for such variables as engine speed, manifold or outside temperature, etc., which are occasionally described as “governors” or “thermostatic.” These arrangements do not maintain an equilibrium between a controlled variable and a reference variable by acting on their difference, instead they simply make an adjustment in a fixed relationship with some independent variable. Because such devices do not employ feedback they are not considered here.

Pressure Control by Relief Valves

Some cars employ pressure regulators that can be classified as feedback systems with similar justification as the safety valves of steam boilers. In such systems the supply pressure of a medium is maintained by an unregulated pump, while protection against excessive pressures is furnished by a relief valve. Examples of this are early gasoline supply systems. On early motorcars the gaso-

line was not, as today, pumped to the engine directly by a gasoline pump; instead a positive air pressure was maintained in the gasoline tank by an engine-driven air pump, which forced the gasoline into the supply line to the carburetor. Installed in the line from the air pump to the gasoline tank was a relief valve set to open at some pressure above normal. Systems of this type are found on the 1912 Simplex automobile (NMHT 309549; Accession 104418) and on the “Model 61” Cadillac (NMHT 308218; mentioned before).⁸⁴ The Cadillac also employs a similar system for regulating the pressure of the engine lubricating oil. The oil is pumped into a main header from where it is conducted to the bearings of the crankshaft, etc. Connected to the header is an overflow valve or “pressure regulator” which at excessive pressures will open up a bypass line.

Voltage and Current Regulation

When motorcars were equipped with storage batteries charged by electric generators, the following problem arose: the current output of a generator is proportional to its generator’s speed of rotation, which on automobiles fluctuates widely, while a storage battery will be damaged if it is charged at a rate exceeding a certain limit. To protect the battery, a variety of systems limiting the generator output have been invented. (These are not to be confused with *cutoff relays* which interrupt the circuit when the generated voltage sinks below the battery voltage.) Two among these stand out: The method of “field distortion regulation,” or “third-brush regulation,” consists of arranging the internal circuitry of the generator so that the output vs. speed curve becomes horizontal for excessive speeds. This removes the cause of danger without resorting to feedback control. In the second method some output-sensing device is mechanically linked to a switch, which breaks the battery circuit at excessive charging rates. Most commonly such

⁸⁴ Oliver and Berkebile, *Smithsonian Collection of Automobiles*, pp. 102–106, 143–145.

devices are designed as vibrators, consisting of a steel reed oscillating between two contacts, attracted to one by a spring, and to the other by the electromagnetic field of a coil in the battery circuit. When at excessive charging rates the electromagnetic force overcomes the spring force, the reed shortcircuits the battery, leaving only a small part of the total current to pass through the battery. Depending on whether the coil is connected in series or shunt, the controlled variable is current or voltage, voltage regulators being the more common. Since the control action is based here on a comparison between a desired value (spring force) and the actual value (force of coil) of a variable, voltage of current regulators of this type must be classified as feedback systems, if only of a level similar to pressure control by relief valve.

Regulators such as these are found, of course, only on automobiles with storage batteries, i.e., cars with electric self-starters. Earlier motorcars, started by hand crank and employing magneto ignition, had no application for such regulators.

The subject of generator regulation has been exhaustively treated in the automotive literature. The following list will only identify the systems employed on the automobiles in the Museum's collection, citing literature where detailed information can be found.⁸⁵

1. 1912 Simplex "Type 50" speedster (NMHT 309549; Accession 104418; serial no. 778): equipped with electric generator and starter motor, both of system "Bijur," factory identification labels illegible; later addition, probably early 1920s. The generator employs third-brush regulation.⁸⁶
2. 1912 Pierce-Arrow "Type 6-36" runabout (NMHT 326222, Accession 255546; serial no. 32813): Pierce-Arrow double-igni-

tion system (magneto and battery system); with vibrator-type regulator, located in "Autocoil" box on dashboard.⁸⁷

3. 1913 Ford "Model T" automobile (NMHT 311052; Accession 120103; serial no. 211098): equipped with Ward-Leonard electric generator and starter motor, both subsequently added. The vibrator-type regulator on the generator is marked "Ward-Leonard Automatic Dynamo Controller Type CC-315 No. 10669."⁸⁸
4. 1917 White bus on 1½-ton "Model TBC" truck chassis (NMHT 326151; Accession 257078): Bosch high-tension magneto-ignition system, to which was subsequently added a North East Electric Co. combination starter-generator (Model GA, Type 3992, serial no. 1773609, 12 volts), employing third-brush regulation.⁸⁹
5. 1918 Oldsmobile "Model 37" touring car (NMHT 323569; Accession 241983; serial no. 153041): Delco 6-volt battery system with third-brush regulation.⁹⁰
6. 1920 American-LaFrance fire truck (NMHT 323518; Accession 250762): Eisemann dual magneto and battery system with vibrator-type regulator.⁹¹
7. 1923 Cadillac "Model 61" chassis (NMHT 308218; Accession 71005): Delco battery ignition system where the generator also serves as starter motor; third-brush regulation combined with a thermostatic regulator sensing excessive charging currents through temperature increases on the generator.⁹²
8. 1924 Franklin "Model 10-C" sedan (NMHT 321454; Accession 244503): Atwater-Kent electrical system with a generator (replacement) by Owen-Dyneto Corporation (Type CG 697, serial no. 648799) using third-brush regulation.⁹³

85. Paul M. Stone, *Electricity and its Application to Automotive Vehicles* (New York, 1924), pp. 354-384; A. L. Dyke, *Automobile and Gasoline Engine Encyclopedia*, 12th edition (St. Louis, no date [approx. 1920]), passim; furthermore, all following automobiles are described in Oliver and Berkebile, *Smithsonian Collection of Automobiles*.

86. Stone, *Electricity and Motor Vehicles*, pp. 561-577.

87. A. L. Dyke, *Automobile Encyclopedia*, 12th edition, p. 278.

88. Stone, *Electricity and Motor Vehicles*, pp. 815-817.

89. *Ibid.*, pp. 701-717.

90. *Ibid.*, pp. 617-621.

91. *Ibid.*, pp. 258-261.

92. *Ibid.*, pp. 630-638.

93. *Ibid.*, pp. 640-643, 658-668.

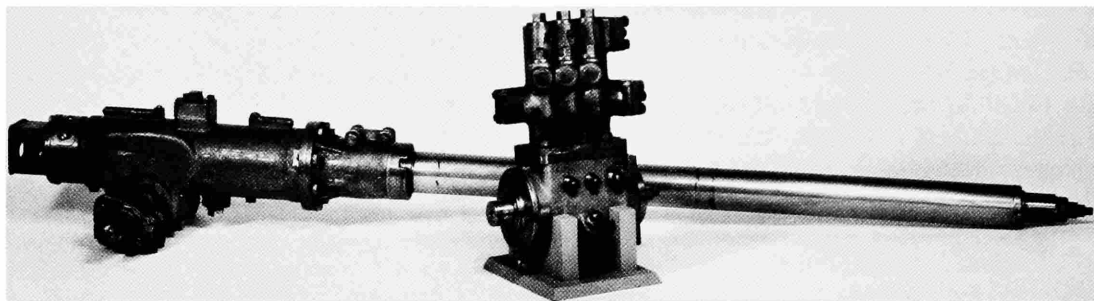

FIGURE 105.—Power steering unit and high-pressure oil pump by F. W. Davis, 1926. (NMHT 314522. Smithsonian photo 71540.)

9. 1940 Bantam $\frac{1}{4}$ -ton Army truck (NMHT 312822; Accession 167398): vibrator-type voltage regulator marked "Autolite Full Voltage Regulator—Current Control; model VRP 4006-G, serial no. 8V17212, 6-volt, max. amps. 25."

Power Steering

Items of special historical interest are the original steering unit and hydraulic pump (Figure 105) of the power steering system invented by Francis Wright Davis of Waltham, Massachusetts (NMHT 314522; Accession 202515). The devices were built in 1925 and installed in the inventor's Pierce-Arrow roadster. In October 1926 Davis drove this car to Detroit, where he demonstrated his invention to a number of automobile manufacturers. Their first reaction was enthusiastic, and some agreements were reached to introduce power steering on one of Detroit's larger cars. But a long series of obstacles, among them the depression and World War II, delayed until 1951 the moment when power steering actually became a huge success in mass-produced passenger cars. Davis's system of power steering was protected by numerous American and foreign patents. The basic one among these, U.S. Patent 1790620 of 27 January 1931 (application filed on 14 April 1926), describes the original system in great detail. Apart from the main element,

the steering unit, the system consists of an oil pump driven by the engine, a bypass pressure regulator, and an oil supply tank. The steering unit outwardly resembles a conventional manual steering column and, like it, it converts the rotation of the steering wheel into a rotation of the Pitman arm shaft which determines the directional angle of the front wheels. The internal arrangement of the steering unit is extremely complex. Its principle of operation is the same as that of a hydraulic servomotor, which has been described before in connection with hydraulic governors. Several special features are added to this: for example, the power steering unit is designed so that it will also work as a conventional manual steering column in the case of failure of the hydraulic power system. Special springs are arranged in such a way as to simulate for the driver the "feel" of the road; provisions are made to avoid internal damage when the front wheels are fully turned to one side while the driver continues to turn the steering wheel.⁹⁴

The history of Francis W. Davis's invention of power steering is the subject of a recent book.⁹⁵

94. Francis W. Davis, "Power Steering for Automotive Vehicles," *Transactions of the Society of Automotive Engineers* 53 (1945):239–256.

95. Houston Branch and Wendell Smith, *The Unreasonable American* (Washington, D.C., 1968).

CHAPTER 10

Feedback Control on Watercraft

Servo Steering Devices

Turning the rudder of a big ship requires tremendous force. Friction and inertia alone are considerable, but on a moving ship they are small compared to the hydrodynamic forces that resist any deflection of the rudder from the direction of travel. Traditionally, when the rudder had to be moved by muscle power, the necessary force had to be provided by employing a sufficiently large number of men (using four men was not uncommon), and by a high-gear ratio. Steering by this

method was neither precise nor responsive. Early in the nineteenth century, when ships grew in size as well as in speed, the need to improve the maneuverability provided a strong motive to search for a source of auxiliary power.

The earliest steam steering gear is believed to have been invented in 1849 by the American Frederick E. Sickels, also known for his invention of a variable cutoff valve gear for steam engines in 1841. His steering engine was patented in 1853 (U.S. Patent 9713 of 10 May 1853) and again, for essentially the

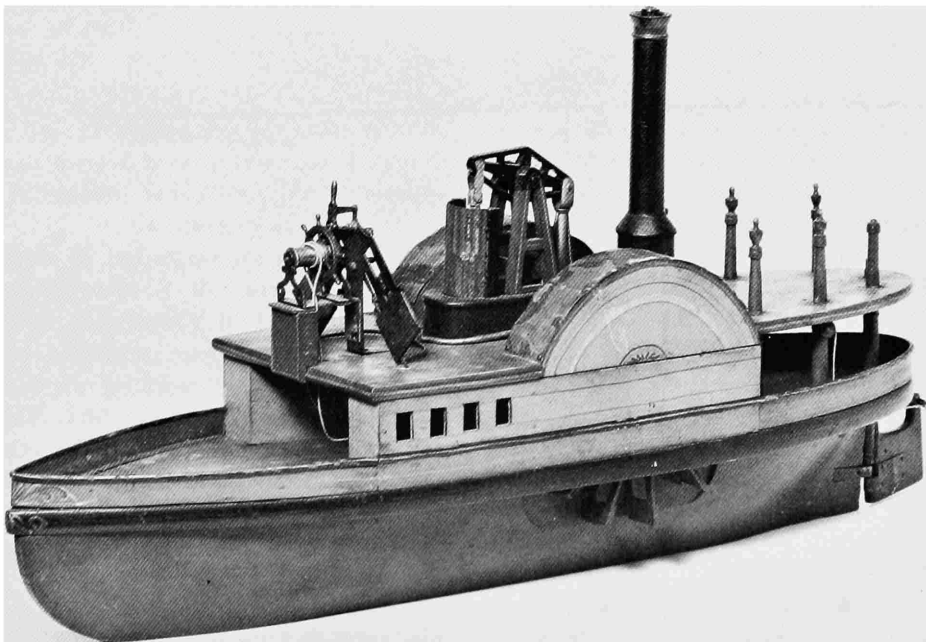

FIGURE 106.—Patent model of Frederick E. Sickels' steam steering gear, 1853. (NMHT 252595. Smithsonian photo 70468.)

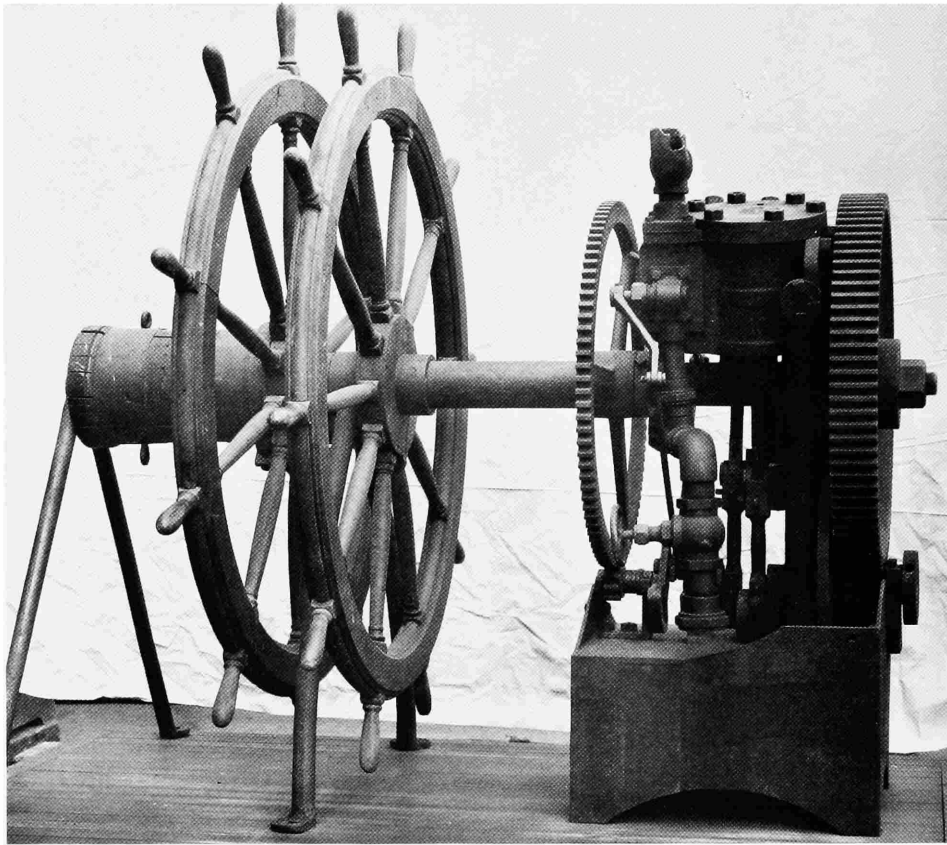

FIGURE 107.—Prototype of Frederick E. Sickels' steam steering gear, 1850s. (NMHT 180024. Smithsonian photo 14488.)

same design, in 1860 (U.S. Patent 29200 of 7 July 1860). The Museum has both patent models (Figure 106) (NMHT 252595 and 252596; Accession 49064), as well as, and more importantly, the original full-scale prototype of this invention (Figure 107), an item with a remarkable history (NMHT 180024; Accession 20574). After being first exhibited in 1853 at the Crystal Palace in New York, this steering gear was later installed on the steamer *Augusta* which operated in the intricate coastal waters of the southern Atlantic seaboard. After two years of successful service, the steering engine was removed from the *Augusta* to be demonstrated on several other ships, and then to be sent to London, where in 1862 it received a medal at the World's Fair. It was once more shown in 1876 at

the Centennial Exhibit of Philadelphia. Sickels' steering gear reportedly worked well; although it received a good deal of praise, and apparently inspired other inventions, it had no commercial success.

Its principle of operation is simple. The apparatus consists of a two-cylinder steam engine arranged in V-formation at an angle of 90°, with valve gear controlled by a common eccentric, and working on a common crankshaft geared to the rudder. The eccentric, however, is not fixed on the crankshaft; instead, a hand crank is attached to it, operated by the steersman. As the action of the valve gear, and consequently the motion of the steam engine, depends on the position of the eccentric, the steering engine will follow, turn by turn, the rotation of the hand

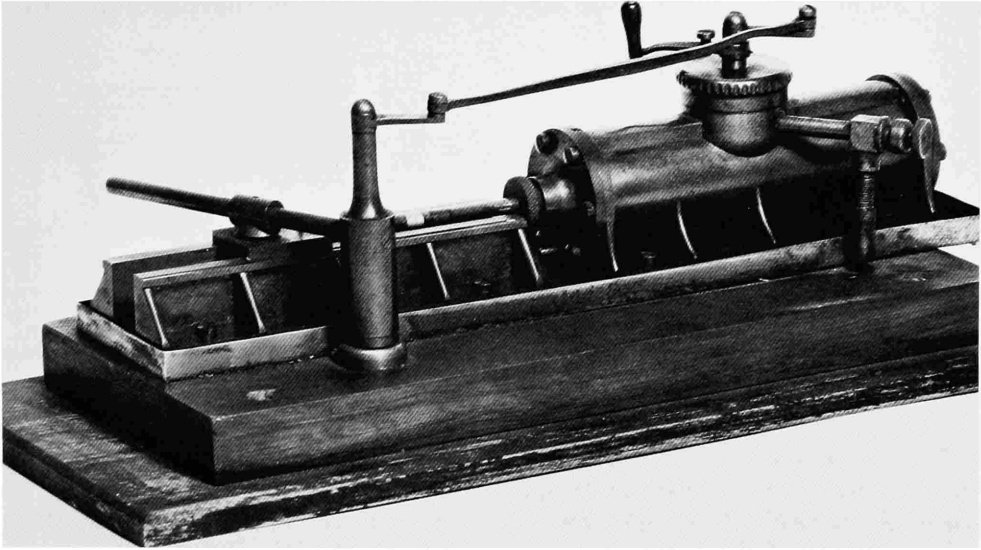

FIGURE 108.—Experimental model no. 1 of servo steering engine, by Herbert Wadsworth, 1870s. (NMHT 310474. Smithsonian photo 70245.)

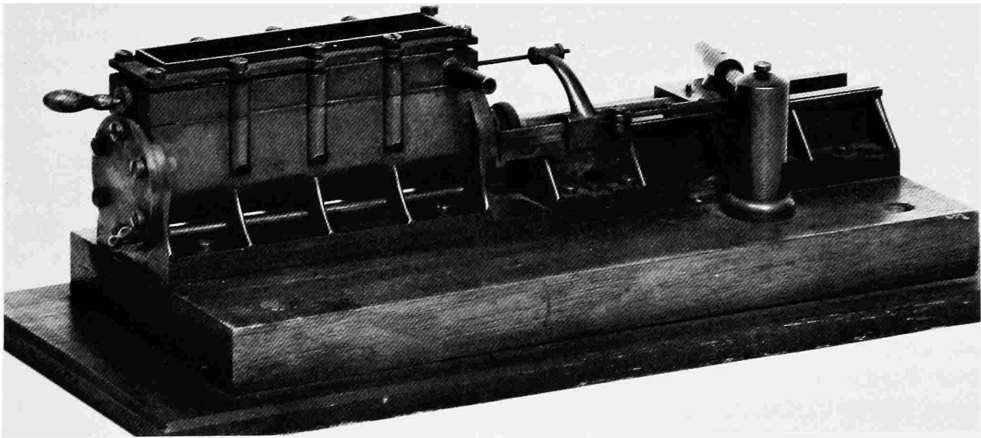

FIGURE 109.—Experimental model no. 2 of servo steering engine, by Herbert Wadsworth, 1870s. (NMHT 310475. Smithsonian photo 70242.)

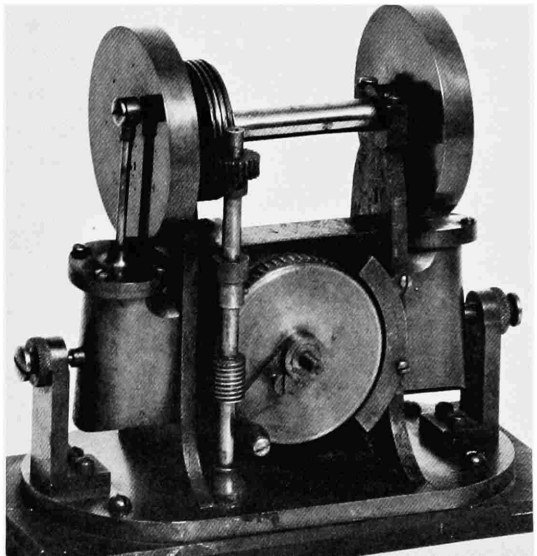

FIGURE 110.—Experimental model no. 3 of servo steering engine, by Herbert Wadsworth, 1870s. (NMHT 310476. Smithsonian photo 70247.)

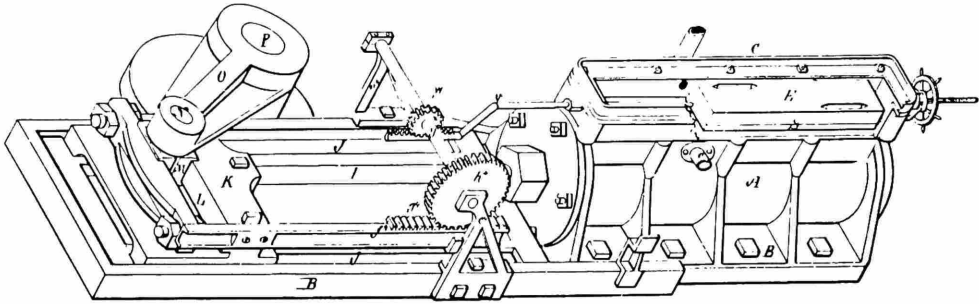

FIGURE 111.—The patented design of Herbert Wadsworth's servo steering engine. Reprinted from U. S. Patent No. 203224 of April 30, 1878, Patent Specifications, fig. 1.

crank. This is, of course, not a feedback system, but instead a typical example of open-loop control, reported here only for the historic importance of the invention.

Another steering engine also without feedback is represented by a patent model by John Gates (NMHT 308559; Accession 89797; U.S. Patent 208231, 24 September 1878). Here two hydraulic cylinders moving the rudder are simply controlled by a hand valve.

Genuine feedback steering systems were invented in 1866 by J. McFarlane Gray, whose steering engine served successfully on the *Great Eastern*, and by the French engineer Joseph Farcot, who in 1872 published the first book on servomotors, relating experiences over the ten previous years.⁹⁶ Our Museum has three operational models of servo steering engines (Figures 108–110) similar to those of Farcot, which date probably from the late 1870s (NMHT 310474, 310475, 310476; Accession 119413). They belonged to Herbert Wadsworth of Geneseo, and later Avon, New York, who on 30 April 1878 received U.S. Patent 203224 on a hydraulic steering engine (Figure 111). The models represent three different versions of the patented invention, but they were apparently not patent models. All three are typical examples of hydraulic servomotors, operating on the same principle as the servo-powered hydraulic governors described earlier. Each one consists of a pilot valve, manipulated by

the operator, determining the side of the power piston to which the high-pressure fluid is admitted. The power piston acts upon the tiller, which in return is connected with the pilot valve by means of a feedback linkage, stopping the flow of power fluid when the tiller holds the desired position. The three units differ only in details of construction. The first two consist of single horizontal power cylinders, the first one using a rotary pilot valve, the second a flat slide valve. On the third model two vertical oscillating cylinders work upon a common crankshaft, set at a phase angle of 90°. A rotary pilot valve is located between the cylinders; the position of the crankshaft is "fed back" to the pilot by means of a worm gear drive, of which one part is missing.

Feedback Control in Torpedoes

THE WHITEHEAD AND THE BLISS-LEAVITT TORPEDO.—Since the American Revolutionary War, the term "torpedo" has been applied to a variety of underwater weapons, but in the modern meaning of the word, the torpedo is distinctly the invention of the British engineer Robert Whitehead who developed it in the late 1860s at Fiume, then an Adriatic base of the Austrian Navy. Whitehead's original torpedo was remarkably mature; it has served as a model for practically all subsequent designs, and its influence is recognizable even in the torpedoes of today. It also had immediate success in the commercial sense. By selling torpedoes to all navies, Whitehead's establishment soon acquired a

96. H. G. Conway, "Some Notes on the Origins of Mechanical Servo Mechanisms," *Transactions of the Newcomen Society* 29(1953–55):57–64.

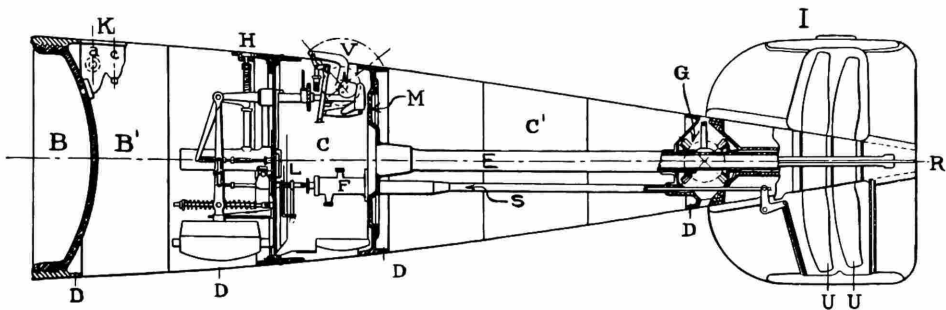

FIGURE 112.—Cross-section of the rear portion of a Whitehead Mark I torpedo, showing the depth-control system. Reprinted from U. S. Bureau of Ordnance, *The Whitehead Torpedo*, 2 vols. (Washington, 1901), vol. 2, pl. 3.

monopoly position that lasted for several decades.⁹⁷

Toward the end of the century some of the major naval powers began to manufacture Whitehead torpedoes under license. The American manufacturing rights for the Whitehead torpedo were purchased by the Brooklyn firm of Bliss & Williams, later E. W. Bliss & Co. One of the first torpedoes produced there, a unit with the serial number 30, built in 1892, is in the collections of our Museum (NMHT 31114; Accession 66742; type "Whitehead 3.55m×45cm Mark I"; 11'8" long, 17.7" diameter, speed 30 m.p.h., range 800 yards). Although considerably more refined in detail, this torpedo reflects quite faithfully the original Whitehead design. Motive power is derived from compressed air contained in a tank in the center section, taking up approximately half of the torpedo's volume. A pressure regulator—in the form of a conventional reducing valve—reduces this high-pressure air to the lower working pressure of the engine, a radial three-cylinder reciprocating engine which drives two coaxial propellers rotating in opposite directions (Figure 112). The working pressure of the engine can be adjusted from outside, a higher working pressure resulting in higher speed

but shorter range, and vice versa. The warhead is located in front of the air tank, while the rear section holds the engine and various control mechanisms.

The most important control device is an ingenious depth-control system, a device that was jealously kept secret for many years so that it acquired a reputation as Whitehead's "Secret." This system (Figure 113) employs two separate sensing elements: one is the spring-loaded hydrostatic piston *d* which expresses the depth of the torpedo's travel—sensed through the hydrostatic pressure—in terms of the compression of a spring. The desired depth can be adjusted easily from the outside by changing the initial compression of this spring. The other sensing element is pendulum *V* swinging in the fore-and-aft plane, sensing deviations from the horizontal in the torpedo's orientation. Both the hydrostatic piston and the pendulum act together through common linkages upon the single rod *f* which, in the original design, was connected directly to the horizontal rudder. As early as 1876, however, the pneumatic servomotor *F* (Figure 114) was added to this arrangement. The control rod now moves only the servo's pilot valve, while the horizontal rudder is tilted by the power cylinder using air at engine working pressure. Apart from the pressure-reducing valve, the depth-control mechanism, and the servomotor, which all use feedback, this torpedo employs a number of open-loop control devices. A starting gear, for example, turns on the

97. For a general survey of the history of the torpedo, see Peter Bethell, "The Development of the Torpedo," *Engineering* (London), 159 (1945):403-405, 442-443; 160 (1945):4-5, 41-43, 301-303, 341-344, 365-367, 529-531; 161 (1946):73-74, 121-122, 169-170, 242-244.

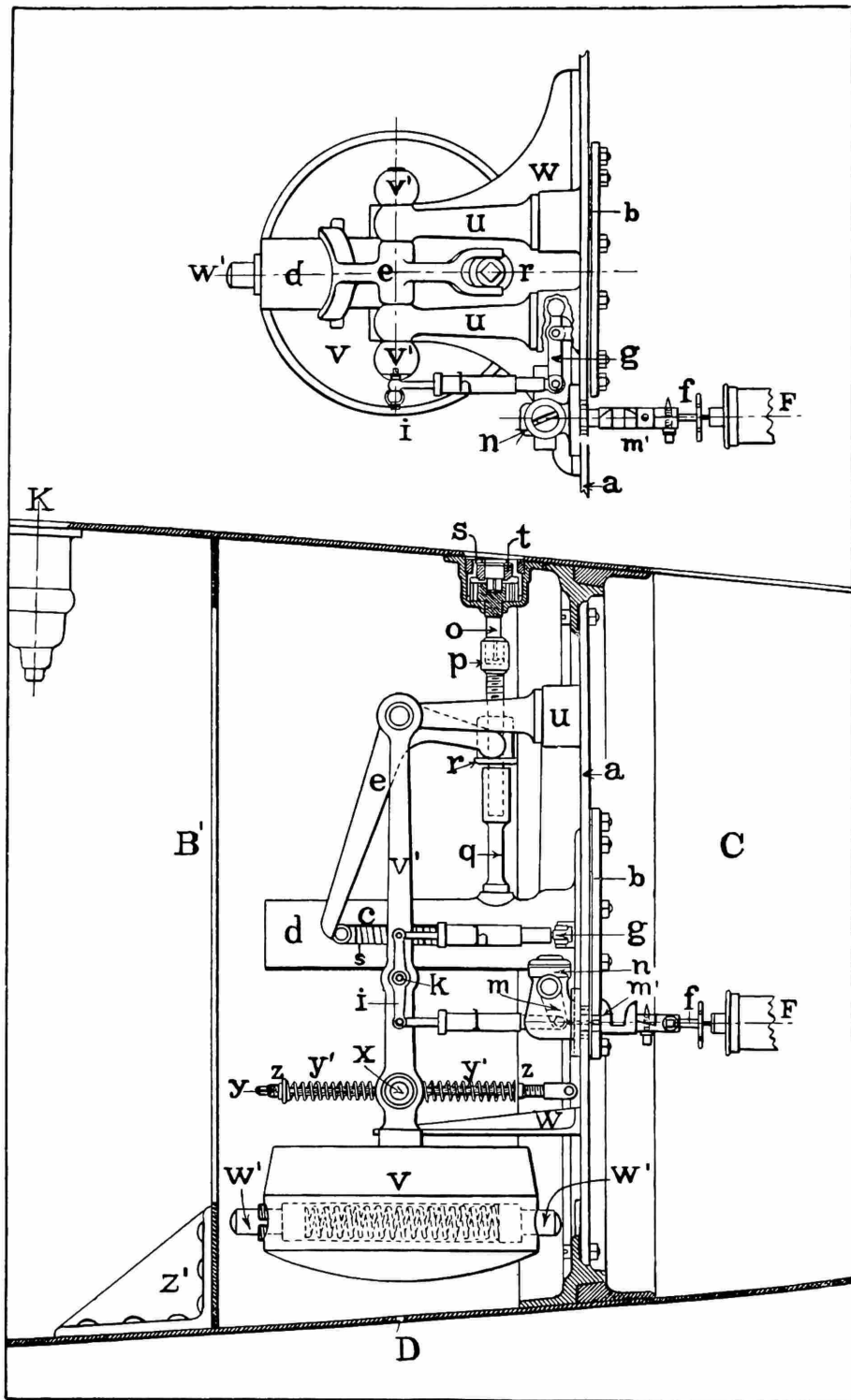

FIGURE 113.—Whitehead Mark I torpedo: the depth-control system. Reprinted from U. S. Bureau of Ordnance, *The Whitehead Torpedo*, 2 vols. (Washington, 1901), vol. 2, pl. 7.

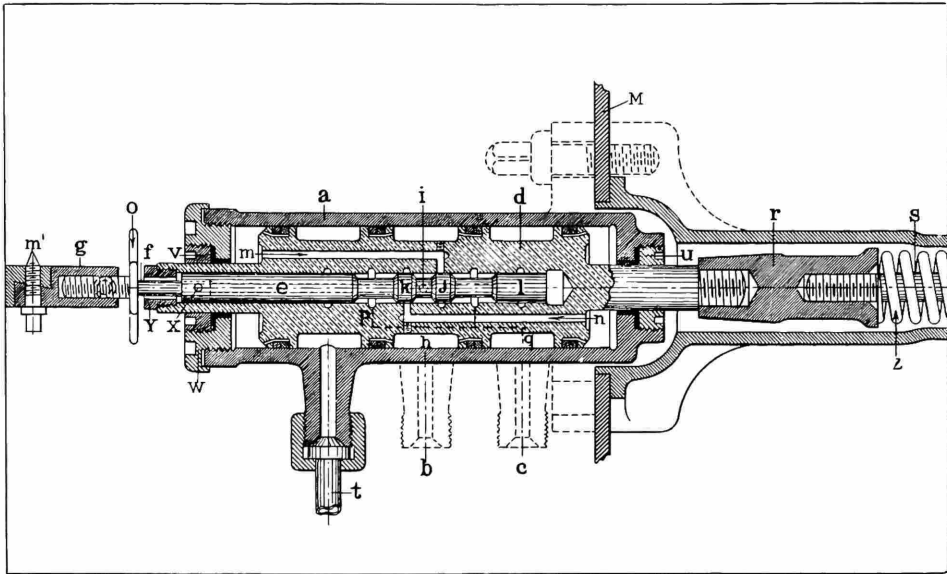

FIGURE 114.—Whitehead Mark I torpedo: pneumatic servomotor powering the depth rudders. Reprinted from United States Bureau of Ordnance, *The Whitehead Torpedo*, 2 vols. (Washington, 1901), vol. 2. pl. 14.

motor when the torpedo leaves the discharge tube; a distance gear—in practice runs—turns off the motor after a predetermined distance; and a sinking gear scuttles the torpedo after an unsuccessful war shot.

As on all earlier models of the Whitehead torpedo, the vertical rudder of our 1892 unit was set experimentally in one fixed position for a straight run. Toward the end of the century, various schemes based on gyroscopes were introduced to keep torpedoes on a straight course. Probably the best known design was that of Ludwig Obry, adopted by the Whitehead establishment in 1895, and only a year later by the United States Navy. Its basic element is a "free gyroscope," a gyro-wheel with three degrees of freedom, spinning on an axis parallel to that of the torpedo, supported in frictionless bearings by a horizontal inner gimbal and a vertical outer gimbal, so that the direction of the spin axis will remain fixed in space regardless of the direction of the torpedo. If the torpedo deviates from the desired direction, this is indicated by an angular displacement of the outer gimbal with respect to the frame of the torpedo. This relative motion is employed

for corrective action; the outer gimbal is directly linked to the pilot valve of a pneumatic servomotor which in turn positions the vertical rudder, so that any deviation from course leads directly to a steering correction. The gyroscope receives its rotation (initially 2400 r.p.m.) from a wound-up spring released at the moment of launching.⁹⁸

A torpedo equipped with an Obry gyroscope, in the collections of our Museum, is the Bliss-Leavitt 20'1"×21" torpedo built in 1912 by the aforementioned Brooklyn firm (NMHT 31115; Accession 66742; serial no. 2169; cutaway). Apart from the gyroscopic steering gear, this unit is distinguished from the basic Whitehead design only by a more powerful propulsive system employing turbines powered by heated air.

THE HOWELL TORPEDO.—In addition to the "Whitehead," the United States Navy used an American-designed torpedo that, although smaller in size, was in some regards superior. This torpedo, developed approximately between 1870 and 1884 by Comdr. John Adams Howell, was powered by the kinetic energy

98. U. S. Bureau of Ordnance, *The Whitehead Torpedo*, 2 vols. (Washington, D.C., 1901).

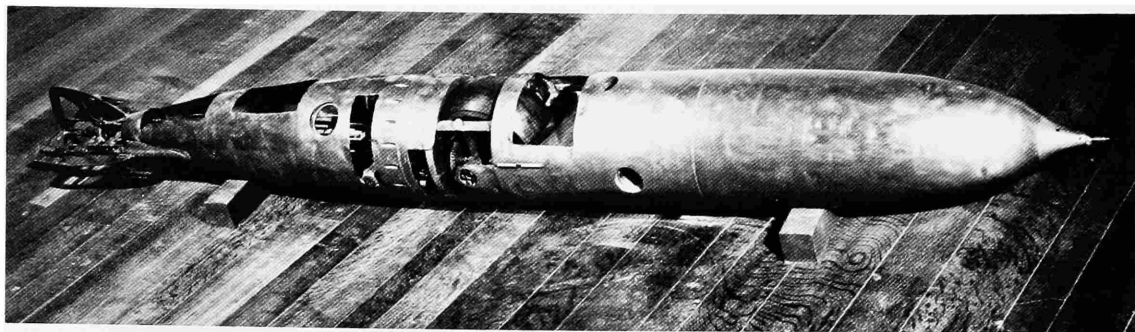

FIGURE 115.—Howell Mark I torpedo, 1890s: the flywheel in which the torpedo's propulsive energy is stored can be clearly seen in the center. (NMHT 53774. Smithsonian photo 71766.)

of a heavy flywheel which was spun up to high speed (about 10,000 r.p.m.) before the launching. The Howell torpedo, consequently, could run without leaving the widely visible telltale wake characteristic of air-driven torpedoes, and furthermore it derived from the gyroscopic properties of the flywheel a degree of directional stability far superior to that of a Whitehead torpedo without Obry gear. The Museum has two identical specimens of this torpedo ("14.2 inches, Mark I"); one was built in 1890 by the Hotchkiss Ordnance Company (NMHT 31113; Accession 66742; serial no. 47), the other is a cutaway demonstration model (Figure 115), presumably also dating from the 1890s, of which further particulars are unknown (NMHT 53774; Accession 190105). The Howell torpedo was undoubtedly inspired by the Whitehead design, but its distinctive propulsion system led to several important differences.

Its immersion regulator, like Whitehead's, combines the action of a hydrostatic piston with that of a pendulum swinging in the fore-and-aft plane, both together controlling the horizontal rudder. Instead of a pneumatic servo, it uses an "impulse mechanism," a mechanical servo system that positions the horizontal rudder according to the output signal of the immersion regulator powered by energy from the flywheel.

More remarkable is the control system responsible for holding the torpedo on a straight course. The heavy flywheel, rotating

at high speed on a horizontal axis perpendicular to that of the torpedo, is mounted rigidly in the middle of the torpedo. Because it is a gyroscope with constrained axis, it will respond with a motion of precession to all forces displacing its axis. Specifically, the gyroscope will react on horizontal forces deflecting the torpedo from its course by rolling the torpedo around its lengthwise axis. The angle of roll, then, serves as a measure of deviation from course; it is sensed by a second pendulum, swinging in an athwartships plane, which acts, again through a mechanical servomechanism, upon the vertical rudder, so as to return the torpedo into its proper course.

One further control device deserves mentioning, although it does not contain feedback. The flywheel is geared directly to the two propellers rotating in opposite directions on parallel shafts. The pitch of these propellers is changed automatically to compensate for the slowing down of the flywheel during the run. The adjustment is carried out according to a rigid program contained in a contoured cam which begins to run off a certain interval after the launching.⁹⁹

OTHER TORPEDOES IN THE MUSEUM'S COLLECTION.—Four other torpedoes can only be listed briefly because descriptive material is not accessible.

⁹⁹ Naval Torpedo Station, Bureau of Ordnance, *The Howell Torpedo: U.S. Navy-14.2"-Mark I: General Description*, (n.p., 1896); Bruce McCandless, "The Howell Automobile Torpedo," *Proceedings, U.S. Naval Institute* 92.10 (October 1966):174-176.

1. German torpedo of World War I, 5.5 m \times 500 mm (NMHT 31155; Accession 66742; 18' long, 19" diameter).
2. Japanese torpedo of World War II, Type 91, Model 5 (NMHT 58762-N; Accession 236599; 17' long, 18" diameter; cutaway).
3. Japanese torpedo of World War II, Type 95, Model 2 (NMHT 58763-N; Accession 236599; 21' long, 18" diameter; cutaway).
4. United States Navy torpedo, contemporary, Mark 37 (NMHT 58761-N; Accession 236599; 21' long, 21" diameter; cutaway).

Gyroscopic Compasses

As phenomena in theoretical mechanics, the properties of the gyroscope were first made known to a wider audience in 1852 by the French physicist Léon Foucault. Foucault described two features. The first is the phenomenon that the axis of a spinning wheel suspended with three degrees of freedom is fixed in space. In this he recognized an alternative to his famous pendulum as a method of demonstrating the rotation of the earth. The proposed method consisted simply in observing under sufficiently large optical magnification the rotation of the gyro axis relative to a reference frame fixed on the earth's surface. From this phenomenon (which allows us to *see* the earth *turn*) he derived the term *gyroscope*. The second property involves a gyroscope with two degrees of freedom. If a weight was suspended from the inner gimbal so as to maintain the spin axis in a horizontal plane, the combined effect of gravity and of the earth's rotation would cause the gyroscope to precess until it aligned itself with the meridian, pointing to the geographic North Pole. Foucault lacked a gyroscope that could rotate at very high speed for a long enough period, therefore, he was not able to demonstrate this latter feature. During the following half century a number of unsuccessful attempts were made to employ this effect in the construction of a compass,

by such men as G. Trouvé, G. M. Hopkins, E. Dubois, Sir William Thomson, Van den Bos, and Werner Siemens. The first practical instrument was that of H. Anschütz-Kämpfe which, after successful tests on shipboard in 1908, was soon widely used in navigation.¹⁰⁰

Elmer A. Sperry (1860–1930), from 1909 to 1911, developed a gyrocompass that was a marked improvement over the Anschütz design. On 11 June 1911 he applied for two patents to cover this invention, which were finally granted as U.S. Patents 1255480 on 5 February 1918 and 1279471 on 17 September 1918. Like those of his predecessors, Sperry's compass was based on the meridian-seeking properties of Foucault's two-degree-of-freedom gyro; his most important improvement was to employ the principle of feedback to make the directional indication of the sensitive element more powerful.¹⁰¹

The operation of the Sperry gyrocompass is very complex. The following brief sketch cannot do more than point out its chief characteristics. Functionally, the instrument consists of two parts, the sensitive element and the follow-up system. The sensitive element is an enclosed gyrowheel driven at high speed by an electric motor. It is suspended with two degrees of freedom, the third being constrained by a pendulum to hold the spin axis in a horizontal plane. This pendulum (termed by Sperry "the bail"), in combination with the gyroscope's rotation around the earth's axis, causes the wheel to precess until its axis lies in the plane of the meridian, pointing to the poles.

The meridian-seeking motion of the sensitive element, however, is not powerful enough to drive with accuracy the various indicating devices of the compass. The orientation of the sensitive element, therefore, is the input for a servo device that adds power to the directional signal. The sensitive element is free to rotate around the vertical axis within the fixed case of the com-

100. Boris V. Bulgakov, *Applied Theory of Gyroscopes*, 2nd edition, trans. J. J. Schorr-Kon (Washington, D.C., 1960), pp. 87–90.

101. Thomas P. Hughes, *Elmer Sperry: Inventor and Engineer* (Baltimore, 1971).

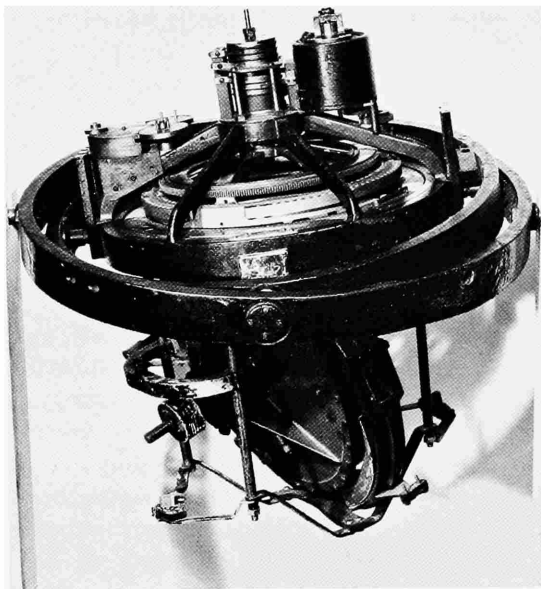

FIGURE 116.—Elmer Sperry's first experimental gyrocompass, 1910. (NMHT 309636. Smithsonian photo 71965.)

pass. Between the sensitive element and the case, on the same vertical axis, rotates a ring-shaped frame, the "phantom element," driven by a reversible electric motor. This motor is connected to two electrical contacts, one positive, one negative, separated by a neutral zone over which slides a trolley attached to the sensitive element. When the sensitive element begins to turn relative to the compass case, the trolley will move from the neutral zone to one of the contacts, switching on the motor so that the phantom will follow the sensitive element until the trolley reaching the neutral zone breaks contact. Consequently, the motor-driven phantom will duplicate closely all motions of the sensitive element, but with a great increase in power. The compass indication is displayed not only on a compass card directly connected to the phantom; it is also transmitted from the master compass to a number of repeater compasses at various locations on the ship.

Three Sperry gyrocompasses are in the collections of our Museum. The oldest is Elmer Sperry's first experimental model (Figure 116), built in 1910, tested in spring 1911 on

the steamer *Princess Anne* (Old Dominion Line) and on the destroyer *Drayton* of the United States Navy. Then it was installed on the battleship *Delaware*, where in August 1911 it performed faultlessly under battle conditions. Consequently, the United States Navy placed their first order for several Sperry compasses (NMHT 309636; Accession 106664; rotor diameter about 14"; the system is assembled on a wooden structure 30"×30"×36").

The gyrocompass Mark 1—Model 2—No. 109 built in December 1912 was the ninth unit ordered by the Navy. Installed on the battleship *Wyoming*, it served as a master for five repeater compasses. As a modification to the original design, it contains a "floating ballistic," a small additional gyroscope stabilizing the connection between the bail and the sensitive element (NMHT 313403; Accession 667424; 19" diameter, 3'8" high).

The Sperry compass Mark 2—Model 9—No. 350 (Figure 117) is designed especially for submarine service, dating probably from World War I. After serving on United States Navy submarines for a number of years, it was installed on submarine *Nautilus* with which in 1931 the Wilkins-Ellsworth expedition approached the North Pole below the ice cap. For this purpose the compass had been converted into a free gyro, because conventional gyrocompasses lose their meridian-seeking properties in the vicinity of the poles. Subsequently, the compass served on the mothership of Admiral R. E. Byrd's Antarctic expeditions of the early thirties (NMHT 39596-N; Accession 245666).

The Sperry Gyropilot

Perhaps the most spectacular invention of Elmer Sperry's is the gyropilot, where he combined the gyrocompass with the servo-steering system of the ship into an automatic steering system capable of replacing the helmsman altogether. Sperry began to work on this invention soon after the gyrocompass had proved successful. The application for his basic patent was filed on 13 November



FIGURE 117.—Sperry “Mark 2-Model 9” gyrocompass, special design for submarine service, World War I; in the 1930s, this compass took part both in North Pole and Antarctic expeditions. (NMHT 39596-N. Photo by Sperry-Rand.)

1914 (granted as U.S. Patent 1360694 on 30 November 1920). The war, however, interrupted this work. After tests in 1922 on three experimental gyropilots, the first ten production models were built in 1923 (serial nos. 101–110). The unit 105 (Figure 118) of this series, installed 17 December 1923 on the tanker *Pennsylvania Sun* of the Sun Oil Co., is now in our Museum’s collections (NMHT 309634; Accession 103045; marked “Sperry Gyroscope Co., New York. Gyro Pilot Mark II, Model 0, Volts 110, Serial No. 105”). It is a duplicate of the gyropilot (serial no. 109) that, also in 1923, was the first to automatically steer a ship (RSMS *Laconia*) around

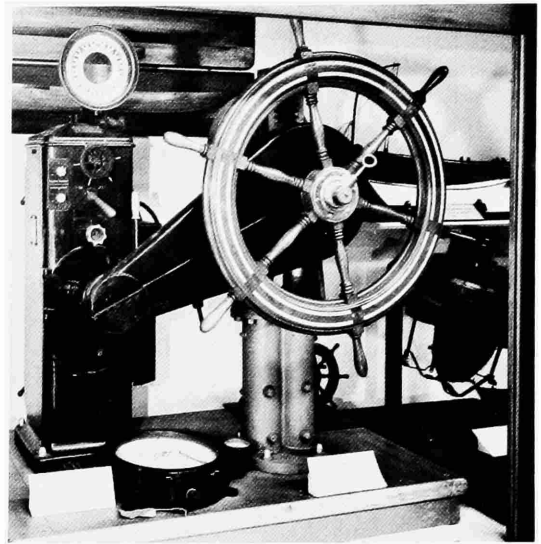

FIGURE 118.—Sperry gyropilot, 1923, shown in its former location at the Arts and Industries Building. (NMHT 309634. Smithsonian photo 43506-B.)

the earth. Under the designation “Single-Unit Gyro-Pilot” this model was manufactured essentially unchanged for many years. In contrast to the later “Two-Unit” and “Triple-Unit” devices, it was designed to be added when a separate servo-steering machine was already installed on the ship.

Apart from the servo-steering system, the principle of which has been described, the gyropilot comprises two feedback loops. The input to the outer, main loop is the desired course, defined as a certain compass bearing, and represented by the angular position of a hand wheel. This signal is compared with the actual heading of the ship, indicated by a repeater compass, by means of a differential gear serving as a mechanical comparator. The resulting error signal—the ship’s deviation from the desired course—serves as the input for a second, internal, feedback loop that will manipulate the steering wheel. This subordinate feedback loop resembles the electric servo system on the gyrocompass. Its input, the deviation from course, is represented by the angle of rotation of a drum carrying positive and negative electrical contact strips separated by an insulating zone. A trolley sliding over this drum is wired to a reversible

D.C. motor. When the system is in equilibrium, the trolley is in contact with the insulating strip; in the event of an error signal the trolley will make contact with one of the conducting strips, energizing the motor so that the steering wheel will be turned in the appropriate direction. The support platform of the trolley, which can also rotate, is connected with the steering wheel by means of a special feedback gear train so that the trolley will follow the insulating strip as the steering wheel is turned. The internal feedback system, as a result, provides proportional control: the angle by which the steering wheel is turned is proportional to the deviation from the desired course.

The output of the gyropilot, the angular position of the steering wheel, is received as a command by the servo-steering system and converted into a proportional angular position of the rudder. The main feedback loop of the system is then closed by the motion of the ship itself. The gyropilot, after comparing the desired direction with the ship's actual heading, turns the steering wheel and through it the rudder. The changed heading of the ship, sensed by the gyrocompass, is then promptly transmitted to the gyropilot which accordingly modifies its output.¹⁰²

102. Sperry Gyroscope Company, *The Gyro-Compass and Gyro-Pilot: Their Operating Principles, Construction and Uses*, Publication No. 17-1610 (Brooklyn, New York, no date [about 1933]), pp. 25-34.

Feedback in Electrical Technology¹⁰³

The Regulation of Electric Arc Lamps

The possibility of employing electric arcs for lighting was recognized early in the nineteenth century. During a public lecture at the Royal Institution in 1809, Sir Humphry Davy used a voltaic battery of 2000 elements to produce a 3-inch arc between two carbon electrodes. From this physical experiment to the development of a practical system of lighting, three obstacles had to be overcome: improving the material of electrodes; finding more economical ways of generating electric current; and regulating the distance between electrodes in such a manner as to produce light of constant intensity. In the context of this catalog, the first problem concerns us not at all, the second indirectly, but the third directly.

The control problem had these implications: (1) An arc of constant intensity can be maintained only if the gap between the electrodes is kept constant; the tips of the electrodes, however, are slowly consumed in operation at an irregular rate. (2) In order to relight an arc lamp after power has been turned off, the carbons first have to be brought into direct contact before they can be drawn apart to produce an arc. (3) Economy requires that more than one lamp can be put into the same circuit. The con-

trol system of the individual lamp, therefore, must function without introducing instability into the overall system.¹⁰⁴

EARLY ARC LAMPS.—The problem of automatically controlling the arc length was first solved around 1848 simultaneously by W. Edward Staite of London and by Léon Foucault, the French physicist.¹⁰⁵

Foucault perfected his lamp in collaboration with his instrument maker Jules Duboscq (1817–1886),¹⁰⁶ under whose name it then was sold with considerable success. A Duboscq lamp (Figure 119) is the oldest arc lamp in our collection (NMHT 315717; Accession 217544; inscribed “J. Duboscq à Paris, Appareil Breveté S.G.D.G. No. 393”; 10½"×5¼"×22½"). It is a relatively late version of Duboscq's design, dating probably from the late 1860s. Its system of regulation is characteristic for that of most early arc lamps. An electromagnet is employed both to sense the magnitude of the gap between the electrodes and to manipulate the electrodes to keep this gap constant. The current flowing through the arc decreases with the arc length. The pull of the electromagnet, however, is directly proportional to the current going through it. Being wired in series with the carbon electrodes, the electromagnet therefore exerts a force upon a spring-loaded

103. The scope of this catalog did not permit inclusion of the electronic devices in the Museum's collection which incorporate feedback in a variety of ways. This seemed to be all the more justifiable as such devices, “black boxes” from the outside and highly complex in their functioning, are generally much less approachable to the Museum visitor than the other objects described here.

104. Francis B. Crocker, *Electric Lighting*, 2 vols. (New York, 1896 and 1901), vol. 2, ch. 15.

105. W. James King, “The Development of Electrical Technology in the 19th Century,” *Contributions from the Museum of History and Technology*, *USNM Bulletin* 228 (1962):334–344.

106. *Dictionnaire de Biographie Française*, under “Duboscq, Jules.”

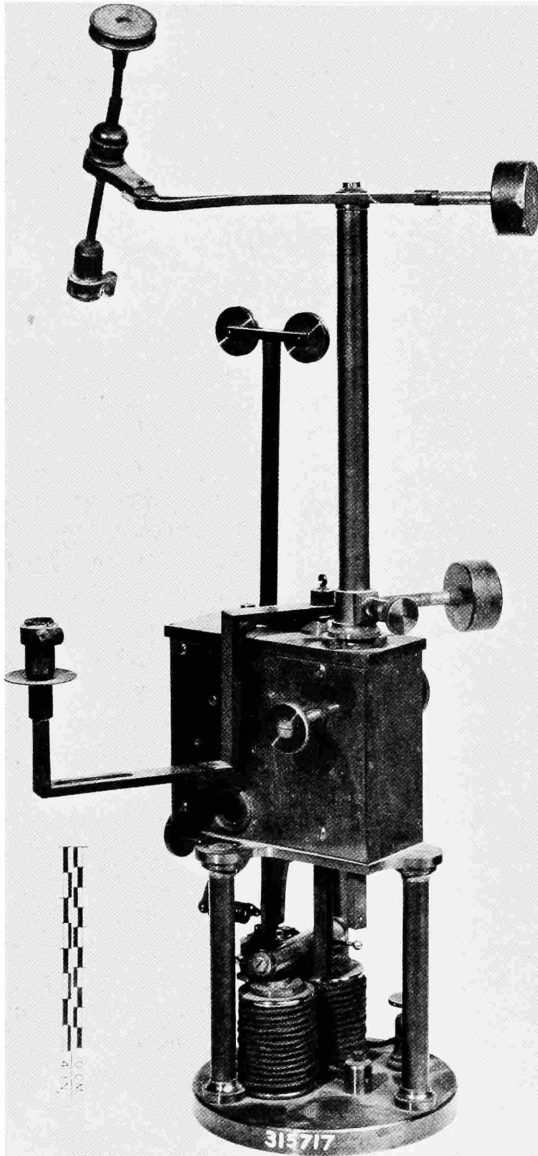

FIGURE 119.—Foucault arc lamp built by Jules Duboscq, 1860s. (NMHT 315717. Smithsonian photo 45391-A.)

armature that is inversely proportional to the gap, reaching a maximum when the electrodes touch each other. This force is used in most systems to regulate the length of arc, although the mechanical details vary widely. In the Foucault-Duboscq system the electrodes are positioned by a spring-powered clockwork that is reversible and therefore

capable of moving the electrodes toward, as well as away from, each other. The direction of motion of this clockwork is determined by the electromagnet. If its pull upon the armature is stronger than the resistance of the spring, then the clockwork will be set in motion to separate the electrodes, and vice versa. Reportedly the Duboscq lamp performed well when carefully maintained but was highly susceptible to damage because of its complexity.¹⁰⁷

In the same class belongs the Siemens-von Hefner Alteneck lamp (Figure 120) from the early 1870s (NMHT 319279; Accession 23501; marked "Siemens Brothers, London No. 177", 4"×4"×24"). As before, the electromagnet is wired in series with the arc. The method of manipulating the electrodes is different. The motion in one direction, toward each other, is caused simply by gravity. The electromagnet begins to act only when the electrodes are too close. Arranged as an oscillator, similar to that of an electric doorbell, it drives the electrodes apart by means of a ratchet mechanism and stops as soon as the arc current has come down to its equilibrium level.¹⁰⁸

Based on the same principle of regulation is the arc lamp of Matthias Day, represented by a patent model for U.S. Patent 147827 of 24 February 1874 (NMHT 251223; Accession 48865; nonoperational mock-up; 4" diameter × 12" high). Here the fine adjustment of arc length is accomplished by a solenoid, wired in series, which directly positions the lower electrode. Also wired in series is an electromagnet which acts as an electric clutch. Whenever, due to carbon consumption, the arc has grown too long, the clutch disengages, permitting gravity to bring the electrodes closer together.

All these early arc lamps, where the regulating electromagnet is wired in series with

107. A. Merling, *Die elektrische Beleuchtung* (Braunschweig, 1882), pp. 248–252; E. Alglave and J. Boulard, *The Electric Light*, trans. T. O. Sloane (New York, 1884), pp. 61–63.

108. Merling, *Die elektrische Beleuchtung*, pp. 311–313; James Dredge (editor), *Electric Illumination* (London, 1882), I:405–406.

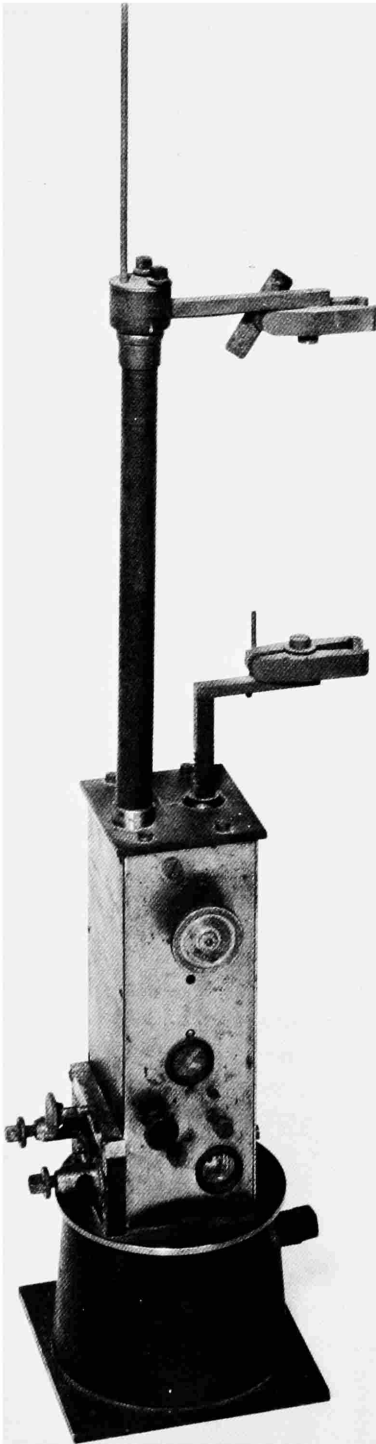

FIGURE 120.—Siemens-von Hefner Alteneck arc lamp, about 1870. (NMHT 319279. Smithsonian photo 71878.)

the arc, have one predominant shortcoming: only one such lamp can be used in a given circuit. If, for example, two lamps were arranged in series, not only would current fluctuations due to control action in the first lamp upset the stability of the other, a breakdown of one lamp would interrupt the circuit altogether. In the laboratory this drawback could be tolerated but not in a system of street lighting.

SYSTEMS OF ARC LIGHTING.—For more than half a century after Sir Humphry Davy's arc-light demonstration, arc lamps depended on electricity generated in chemical batteries. Their use was limited therefore to special events such as gala performances of opera or to the physics laboratory. In the mid-1870s, with the arrival of the self-excited generator, this state of affairs changed abruptly. The lighting of streets and public buildings offered the first opportunity for employing the newly found cheap electricity on a larger scale. Almost simultaneously, a number of technically sound systems of arc lighting made their appearance. In America among the earliest were those of Wallace-Farmer, Brush, Thomson-Houston, and Weston, of which, at least at the beginning, the Brush system emerged as the most successful.¹⁰⁹

Generally each of these systems was distinctive not only in the design of its arc lamps but also in its other main components, chiefly the generator. In the present context, we will discuss only the regulation of the arc lamps. Other instances of feedback control in the overall system will be treated later such as the current regulation of the generators.

The Brush System: The first system of electric lighting to attain commercial success was that of the Brush Electric Co. of Cleveland, Ohio. In our collections the oldest related item is a patent model (Figures 121 and 122) by Charles F. Brush (U.S. Patent 203411 of 7 May 1878; NMHT 252649; Accession 49064; 5" diameter, 12" high). It is a simple

109. Harold C. Passer, *The Electrical Manufacturers, 1875-1900: A Study in Competition, Entrepreneurship, Technical Change, and Economic Growth* (Cambridge, Massachusetts, 1953), pp. 11-71.

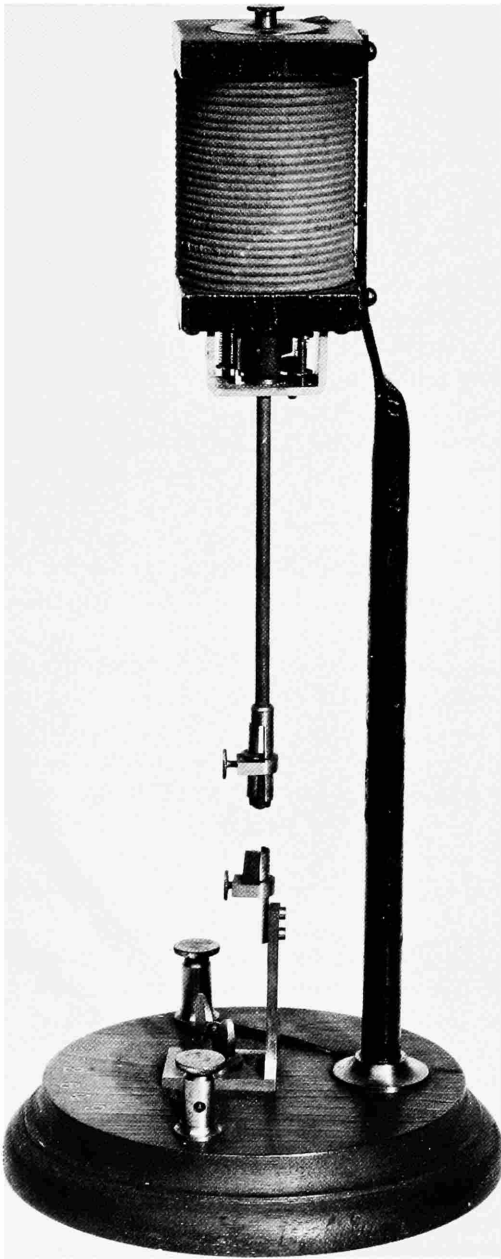

FIGURE 121.—Patent model of arc lamp by Charles F. Brush, 1878. (NMHT 252649. Smithsonian photo 44552-E.)

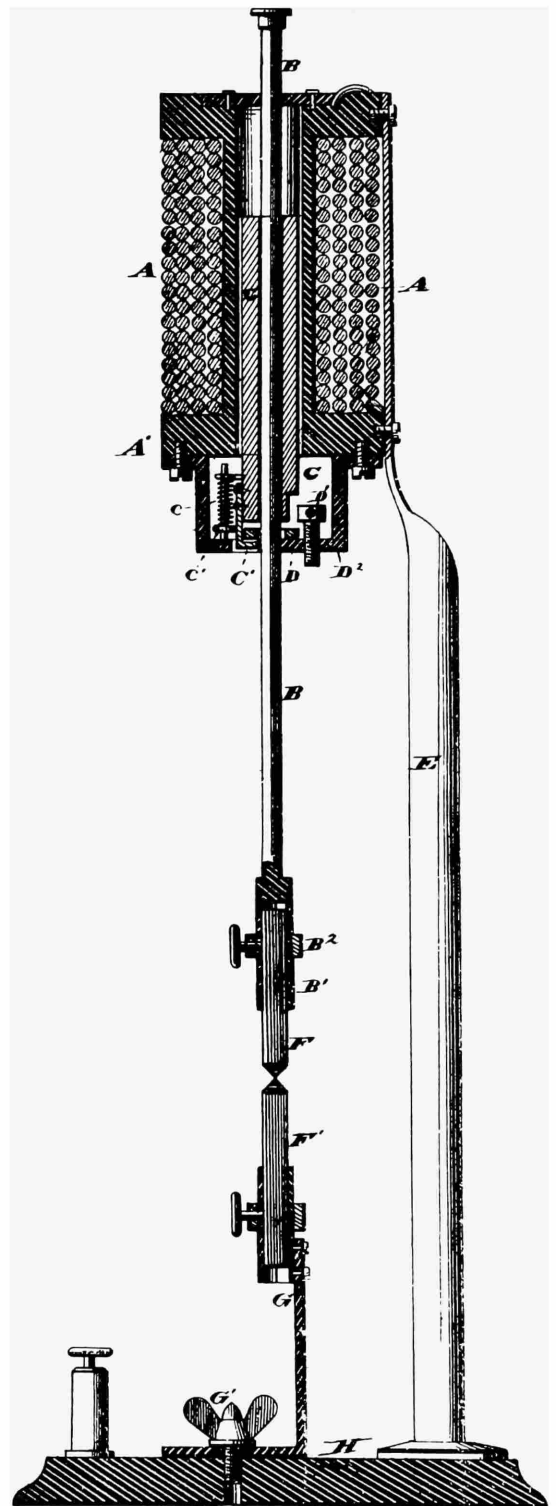

FIGURE 122.—Cross-section of Brush arc lamp NMHT 252649. Reprinted from *U. S. Patent No. 203411 of May 7, 1878, Patent Specifications, fig. 1.*

arc lamp in which the regulating solenoid is wired in series with the arc so that only one lamp can be used per circuit. The system of regulation is this: while the lower electrode is fixed, the upper one is attached to a metal rod that is free to slide downward under the effect of gravity but is suspended by the solenoid through a friction clutch. This friction clutch, the patented feature, was to become a standard component of Brush arc lamps. It consists simply of a flat washer fitting loosely over the suspended rod. When its axis is aligned with that of the rod, it will slide freely; if, however, it is tilted, it will firmly seize the rod. The core of the solenoid, when energized, will lift up one side of the washer; by thus engaging the friction clutch, it will pull the supporting rod upward. If the solenoid is not energized, the washer will settle flatly on a supporting ring, permitting the rod to slide downward until it meets the lower electrode. Closing the circuit and reestablishing the arc will reenergize the solenoid, which will pull the supporting rod upward until its magnetic force, with decreasing arc current, will return to a level where it just balances the weight of the upper electrode and its supporting rod.¹¹⁰

Production models of Brush arc lamps embodying this patent are two identical table lamps (Figure 123), probably for laboratory purposes, of the 1880s (NMHT 181554; Accession 32407; serial no. 13013; and NMHT 325989; Accession 256489; serial no. 13014; size 4"×8"×28"). They are wired in the fashion of the Foucault lamp where only one lamp can be used in a given circuit.

Our next patent model (Figure 124) of a Brush arc lamp (U.S. Patent 212183 of 11 February 1879) offers a solution to this problem (NMHT 251232; Accession 48865; 6" diameter, 12" high). In the use of the customary friction clutch, this lamp is mechanically equivalent to the preceding one. The difference is only electrical. The new

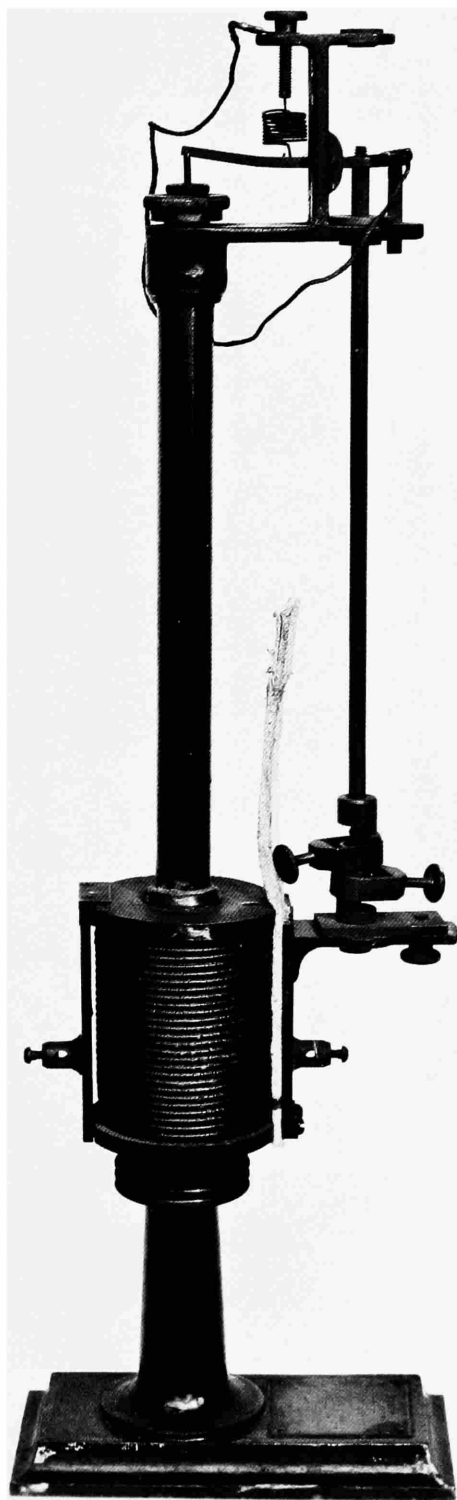

FIGURE 123.—Brush arc lamp, 1880s. (NMHT 181554. Smithsonian photo 44552-B.)

110. Paget Higgs, *The Electric Light in its Practical Applications* (London, 1879), pp. 35–37; John W. Urquhart, *Electric Light, its Production and Use*, 3rd edition (London, 1890), pp. 335–342.

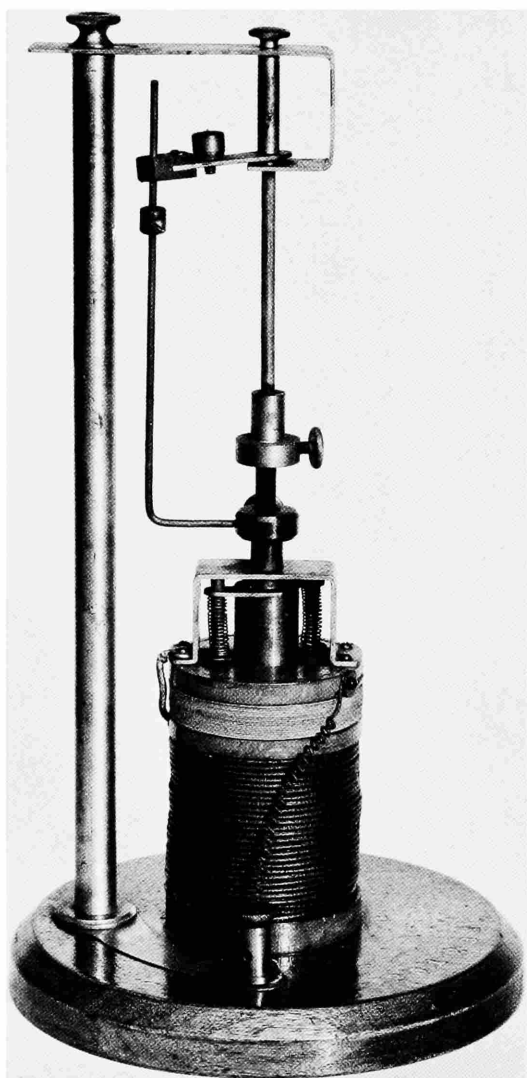

FIGURE 124.—Patent model of arc lamp employing differential circuit, by Charles F. Brush, 1879. (NMHT 251232. Smithsonian photo 44552-F.)

“differential” circuit permits any desired number of such lamps to be connected in series. The solenoid consists of two separate coils. The main coil is wired, as before, in series with the arc. The other one, the shunt coil, is connected parallel to the whole lamp; it has roughly the same number of turns but a much higher resistance and is wound in the opposite direction to the first, so that the

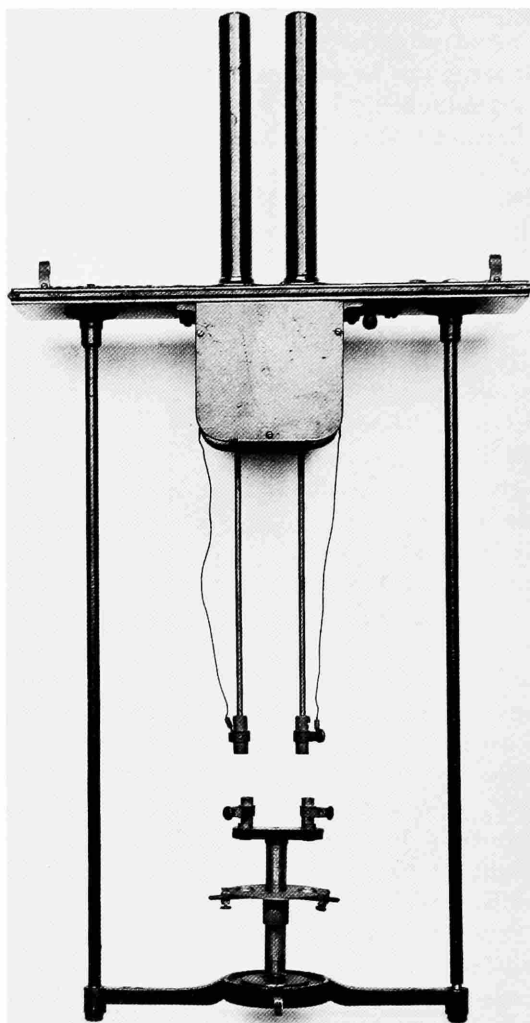

FIGURE 125.—Patent model of double-arc lamp by Charles F. Brush, 1879. (NMHT 251230. Smithsonian photo 44552-A.)

magnetic force induced by it will counteract that of the main coil. While the main coil, when energized, draws the electrodes apart, the shunt coil—acting in the same direction as gravity—brings them together. In normal operation only a small fraction of the total current will flow through the shunt coil. When the main circuit, however, is interrupted, the shunt coil will (1) act as a bypass to the arc, thus assuring the continuity of operation of other lamps in the same line;

and (2) draw together the electrodes in order to relight the arc.¹¹¹

The Brush system achieved its first triumph in 1878 with the installation of twenty arc lamps in the Wanamaker department store in Philadelphia. For the lamps used here, C. F. Brush took out another patent (U.S. Patent 219208 of 2 September 1879). The patent model accompanying this application, a full-scale production model (Figure 125), is in our collection (NMHT 251230; Accession 48865; serial no. 345; 24"×47" high). This lamp combines various previously patented features—the friction clutch, the differential circuit, and the cutoff relay (a magnetic switch bypassing the lamp when the arc is broken)—with a new dual-arc arrangement: the lamp was equipped with two sets of electrodes working alternately to lengthen the operating period.

Two actual street lamps in our collection are very similar to this lamp. The older one, a single-arc lamp, is unmarked (NMHT 327945; Accession 271855; 18½"×33" high), but its regulator is of the same design as the previous lamp. The other one is a dual-arc lamp marked "Brush E. Co. Standard; No. A/31/20667, 9.6 amperes. Patented by C. F. Brush: Feb. 11, 1879; Sept. 2, 1879; Nov. 16, 1880; Feb. 10, 1885. T. E. Adams Patent May 27, 1888; other patents pending." (NMHT 327946; Accession 271855; 8"×46" high).

Several other patent models of arc lights by C. F. Brush in the Museum's collection do not contain feedback.

The Wallace-Farmer System: The lighting system of William Wallace and Moses G. Farmer, one of America's earliest, used the traditional method of regulation. The solenoid is wired in series with the arc; the upper electrode approaches the lower one by gravity, but in order to spring (start) the arc it is lifted upward slightly by the solenoid through a friction clutch similar to that of C. F. Brush. The Wallace-Farmer arc lamps are distinguished only by the unusual form of their carbons, which are shaped not as

pencils but instead as plates of considerable width. For a given life span such carbons require far less adjustment. This shape of carbon electrode was patented by William Wallace in 1877 (U.S. Patent 198436 of 18 December 1877. The actual patent model, without any control device, is in our Museum

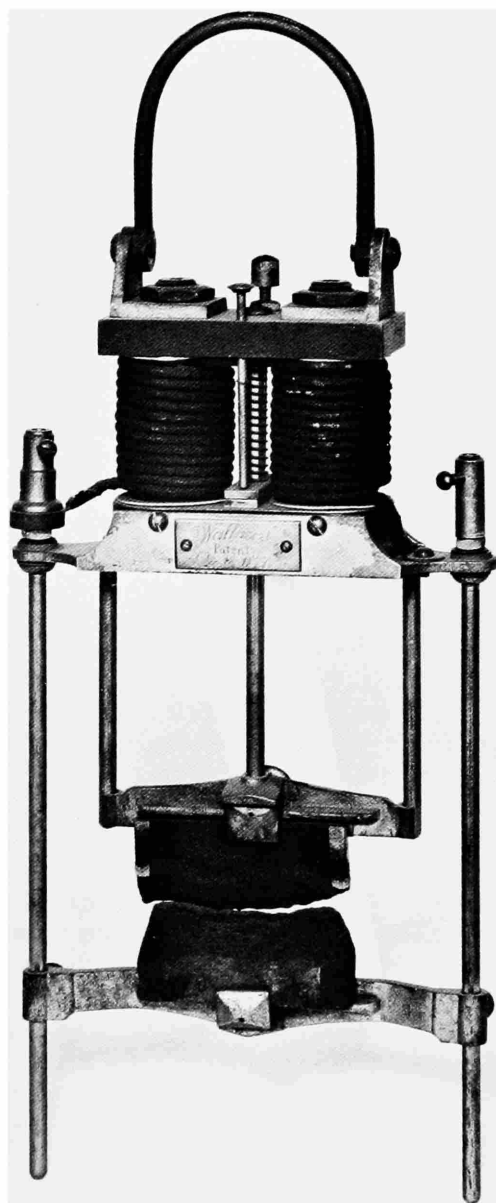

FIGURE 126.—Wallace arc lamp, 1880s. (NMHT 201365. Smithsonian photo 71887.)

111. Crocker, *Electric Lighting*, II:339.

under NMHT 251235). Our Museum has two such early Wallace-Farmer arc lamps, dating probably from the early 1880s (1. NMHT 201365; Accession 35164; marked "Wallace's Patent, Dec. 18, 1877"; 7"×16½" high [Figure 126]. 2. NMHT 201363; Accession 35164; serial no. 117; marked "Wallace Electric Lamp, Patented Dec. 18, 1877. Manufactured by Wallace & Sons, Ansonia, Conn. USA"; 15½" wide, 14" high).¹¹²

Of Moses G. Farmer, Wallace's collaborator, the Museum has two experimental arc lamp regulators dating probably from the 1880s. (1. NMHT 181973; Accession 34583; double magnet, clockwork, etc., on wooden base 12"×12". 2. NMHT 181974; Accession 34583; wooden box, 6½"×9½"×9").

The Thomson-Houston System: Elihu Thomson and Edwin J. Houston, two high school science teachers from Philadelphia, devised a system of arc lighting that appeared on the market in 1879. The Thomson-Houston Company, formed to promote their inventions, proved enormously successful. The company purchased the Brush Electric Co. in 1889, and in 1892 it became one of the parent firms of the present General Electric Company.¹¹³

Our Museum has the patent model (Figure 127) for the first arc-lamp patent by E. Thomson and E. J. Houston (U.S. Patent 220508 of 14 October 1879; NMHT 251233; Accession 48865; 7"×11" high). Its main distinction from the arc lamps encountered so far is the circuit used. C. F. Brush had solved the problem of how to connect a larger number of arc lamps in series by wiring each lamp with the "differential circuit" described earlier. The Thomson-Houston lamps instead used the "shunt circuit," on which the lamp patent of 1879 (Figure 128) is based.¹¹⁴ Each circuit has a shunt line bypassing the arc. In the "differential" circuit the main line and the shunt line each contain a solenoid, wound in opposite directions, acting against each

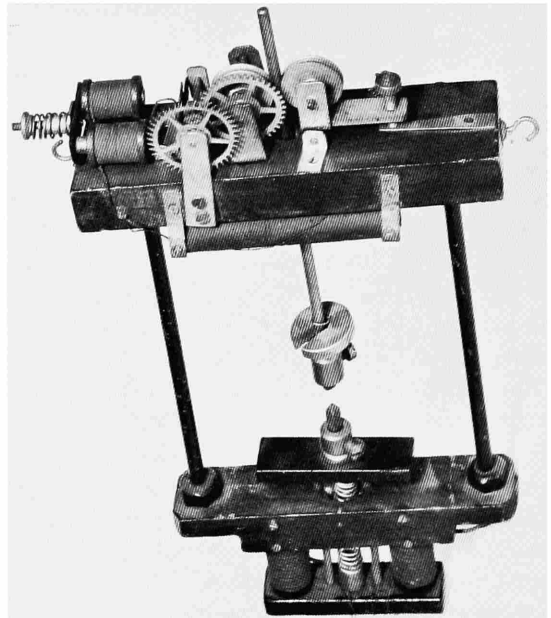

FIGURE 127.—Patent model of arc lamp by E. Thomson and E. J. Houston, 1879. (NMHT 251233. Smithsonian photo 71886.)

other. In the "shunt" circuit the electromagnet controlling the arc gap is in the shunt line alone. If the current bypassing the arc becomes too powerful due to an excessive arc gap, this electromagnet is energized and releases an escapement permitting the upper electrode to move downward under the effect of gravity. A second electromagnet, wired in series with the main circuit, when energized pulls the electrodes apart against the force of a spring. Its purpose is only to establish an arc after the current has been turned on at start-up. The advantages claimed for the "shunt circuit" are that the regulation is unaffected by sudden variations in arc resistance, and that the mechanism is essentially independent of current strength. Lamps designed according to this patent were first installed at a Philadelphia bakery in 1879.

Subsequent Thomson-Houston, and later Thomson-Rice, arc lamps differed considerably in mechanical aspects but retained the "shunt circuit." Representative for this later stage of development is a Thomson-Rice double arc lamp (Figure 129) of the late

112. Dredge, *Electric Illumination*, I:410–413.

113. Passer, *Electric Manufacturers*, pp. 21–31.

114. For a discussion of the "shunt" circuit versus the "differential" circuit, see Crocker, *Electric Lighting*, II:338–340.

E. THOMSON & E. J. HOUSTON.
Regulator for Electric-Lamp.

No. 220,508.

Patented Oct. 14, 1879.

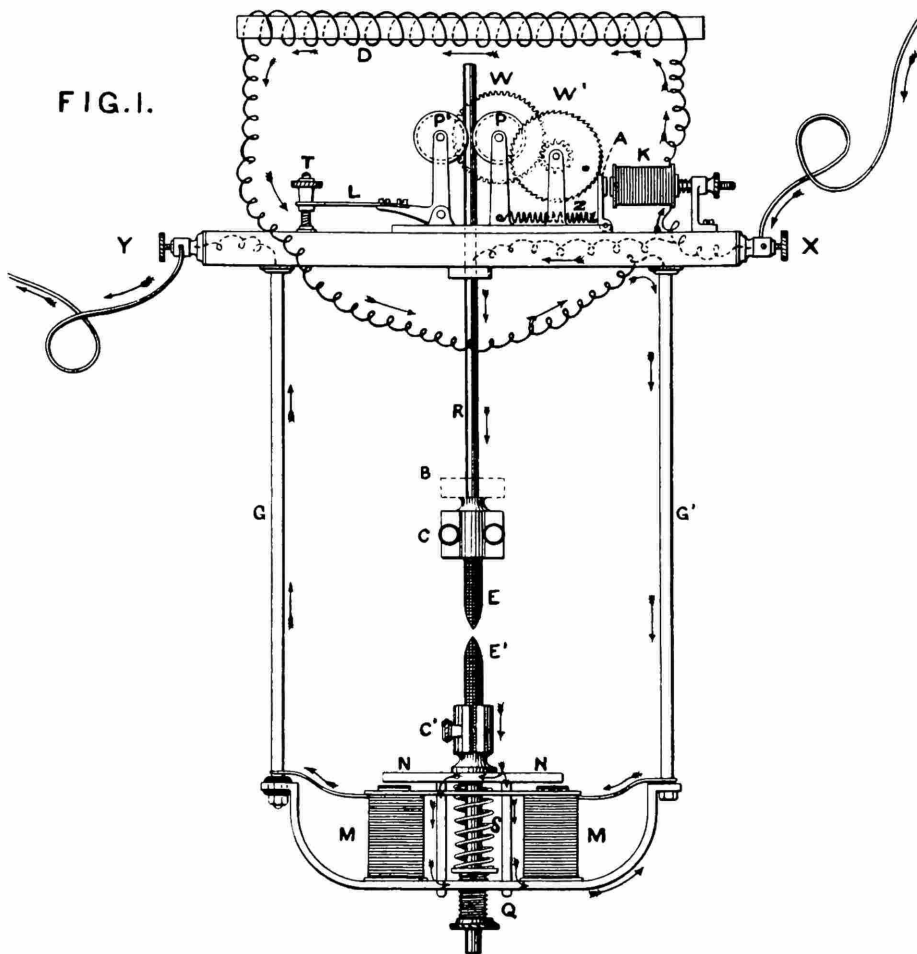
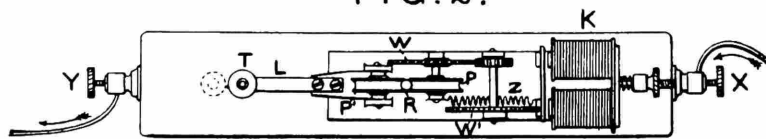

FIG. 2.



WITNESSES.

A K INVENTORS

Geo. A. Vallant,
Thos. A. McCollin

Elmer Thomson
Edwin J. Houston

FIGURE 128.—Patent specification drawing for Thomson-Houston arc lamp NMHT 251233. Reprinted from U. S. Patent No. 220508 of Oct. 14, 1879.

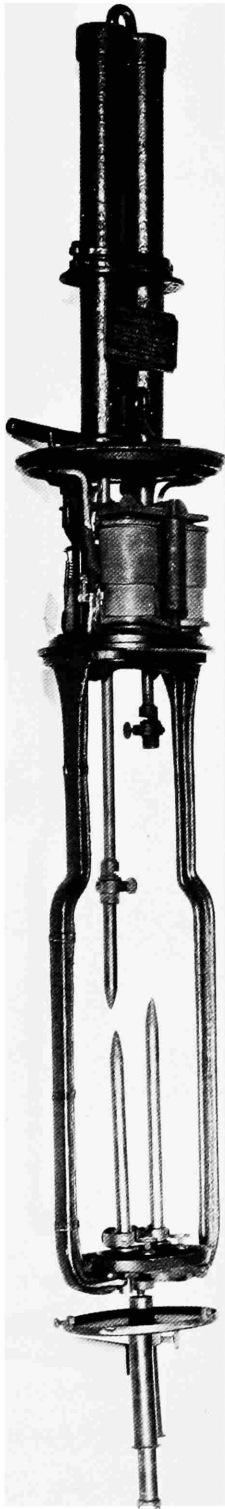

FIGURE 129.—Thomson-Rice double-arc lamp, late 1880s. (NMHT 219016. Smithsonian photo 71885.)

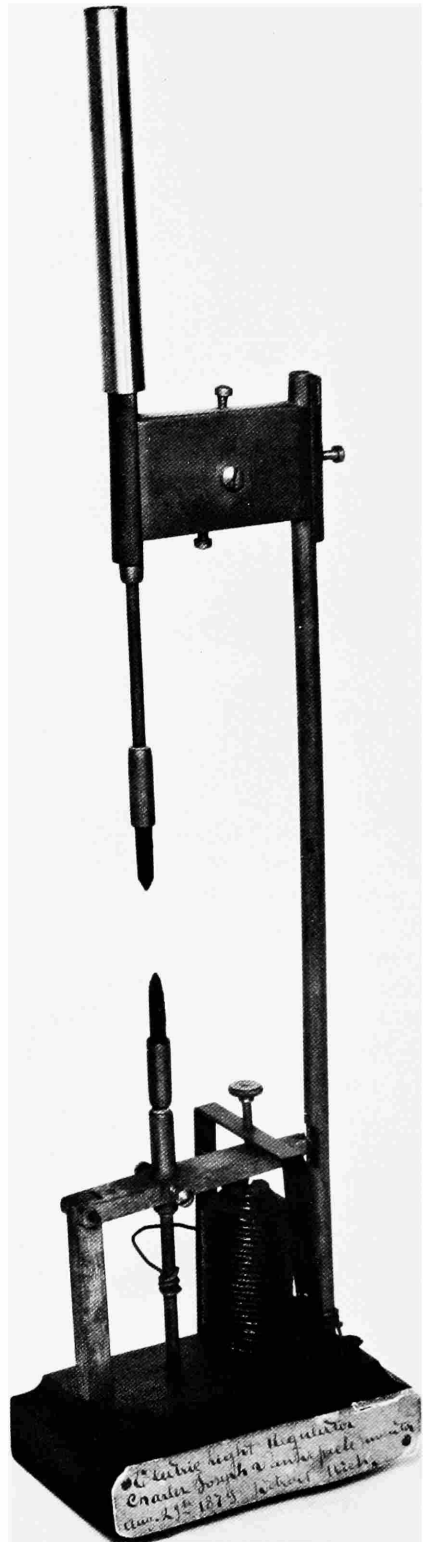
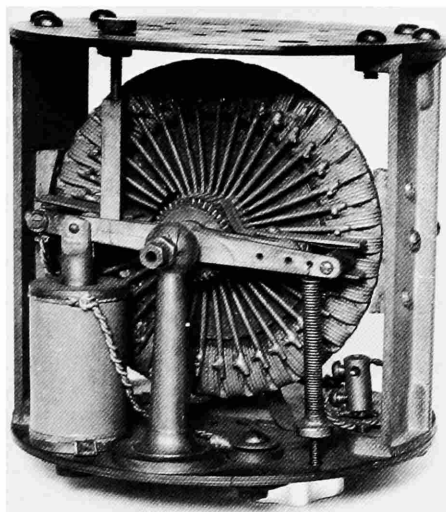
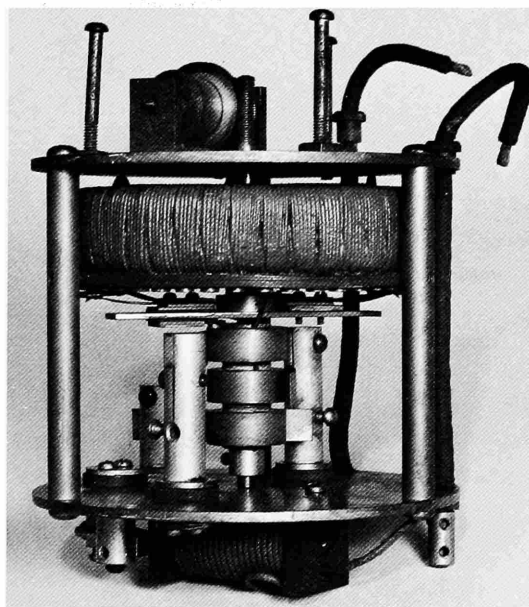

FIGURE 130.—Patent model of arc lamp by Charles J. Van Depoele, 1880. (NMHT 252652. Smithsonian photo 71877.)

FIGURES 131-134.—Patent models of arc lamp regulating mechanisms by Charles J. Van Depoele, 1882-1884:



131. (NMHT 308597. Smithsonian photo 71880.)



132. (NMHT 251222. Smithsonian photo 71881.)

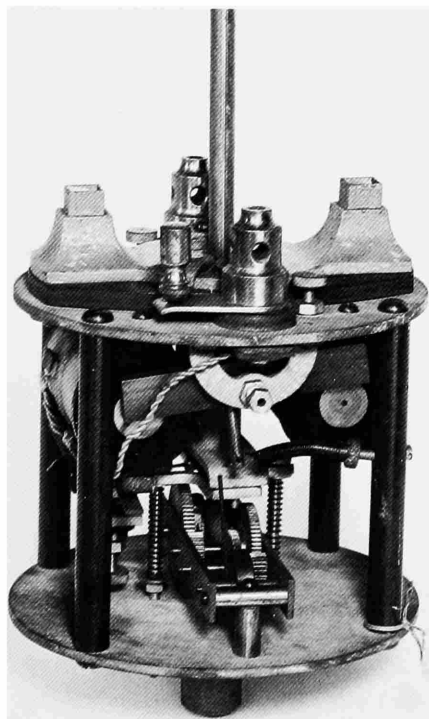

133. (NMHT 251227. Smithsonian photo 71875.)

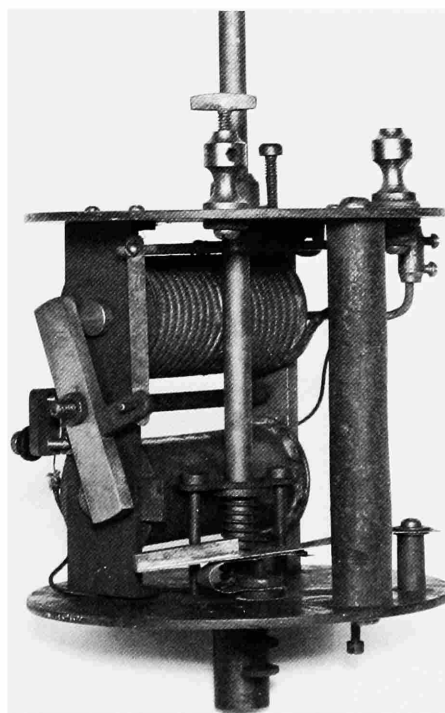

134. (NMHT 308598. Smithsonian photo 71876.)

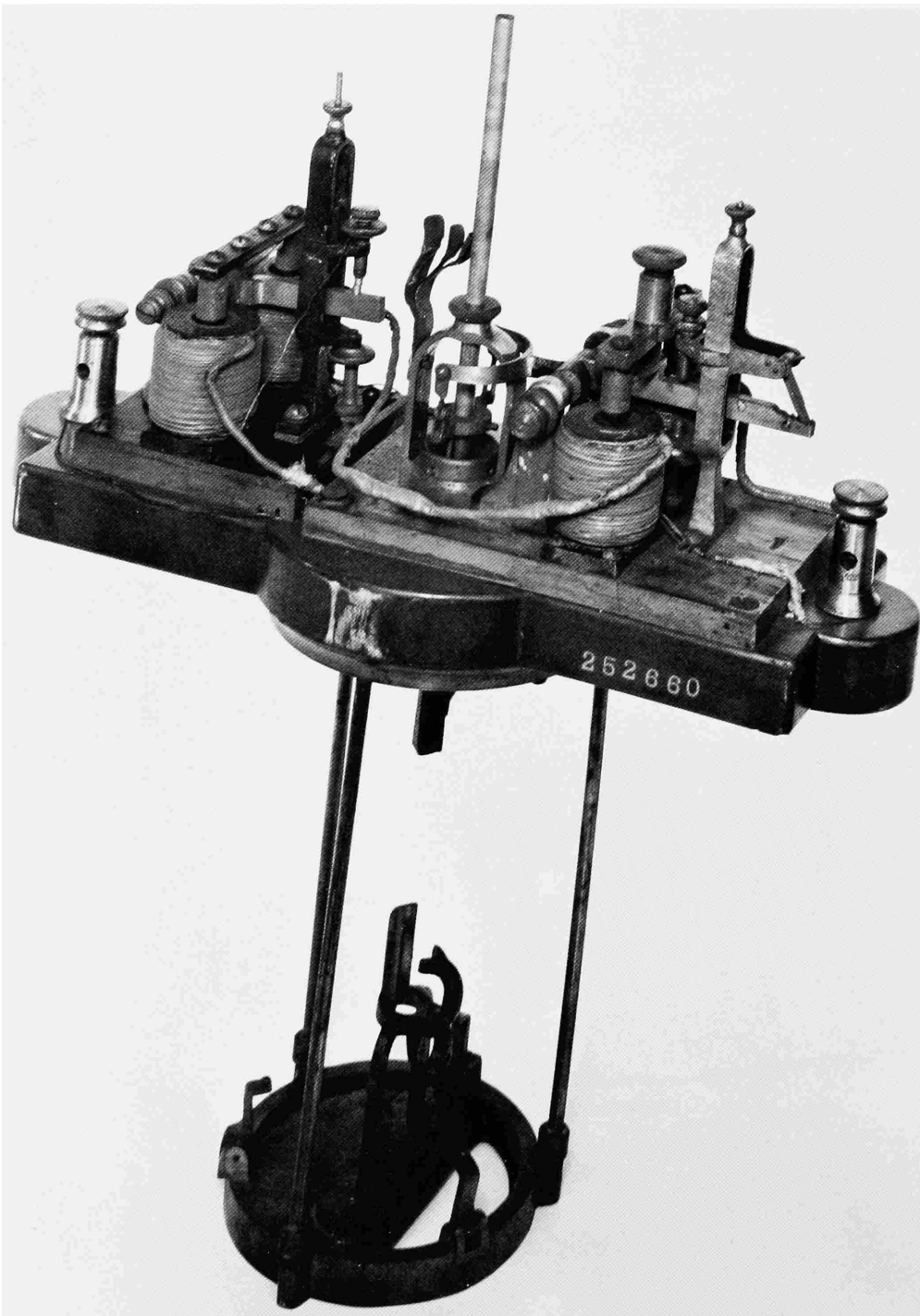

FIGURE 135.—Patent model of arc lamp by Edward Weston, 1881. (NMHT 252660. Smithsonian photo 71884.)

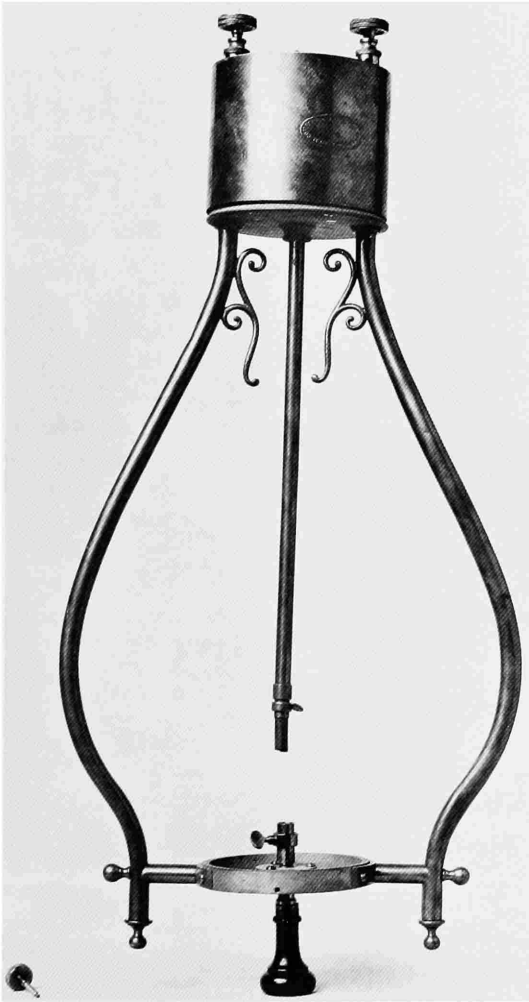

FIGURE 136.—Patent model of arc lamp by N. S. Keith, 1882. (NMHT 251225. Smithsonian photo 29680.)

1880s (NMHT 219016; Accession 40913; "Class M," No. 92737; 8"×52" high).¹¹⁵

MISCELLANEOUS ARC LAMP REGULATORS.—The Museum's collection contains a considerable number of other automatically regulated arc lamps. They are mostly patent models from the 1880s, when for a brief period arc

light was the predominant form of electric light. These are listed without detailed explanation:

NMHT 252655; Accession 49064: patent model by Hiram S. Maxim (later Sir Hiram) for U.S. Patent 208252 of 24 September 1878. Full-scale arc lamp, now incomplete; base 7½" diameter, 27" high.

NMHT 252656; Accession 49064: patent model by Hiram S. Maxim for U.S. Patent 230953 of 10 August 1880. A small, simple wooden mock-up of an arc-lamp regulator; 9"×7"×7".

NMHT 252652; Accession 49064: patent model (Figure 130) by Charles J. Van Depoele for U.S. Patent 227078 of 27 April 1880. A small but apparently operational model of a simple arc lamp, 2"×3½"×14¾".

NMHT 308597; Accession 89797: patent model by Charles J. Van Depoele for U.S. Patent 261260 of 18 February 1882 (Figure 131). Regulating mechanism only; full scale; 6" diameter, 12½" high.

NMHT 251222; Accession 48865: patent model by Charles J. Van Depoele for U.S. Patent 291553 of 8 January 1884 (Figure 132). Regulating mechanism only; full scale; 6" diameter, 8" high.

NMHT 251227; Accession 48865: patent model by Charles J. Van Depoele for U.S. Patent 291651 of 8 January 1884 (Figure 133). Regulating mechanism only; full scale; 6¼" diameter, 11½" high.

NMHT 308598; Accession 89797: patent model by Charles J. Van Depoele for U.S. Patent 294165 of 26 February 1884 (Figure 134). Regulating mechanism only; full scale; 6" diameter, 6¼" high.

NMHT 252660; Accession 49064: patent model by Edward Weston for U.S. Patent 240210 of 12 April 1881 (Figure 135). One of twelve arc-lamp regulator patents that Weston took between 1880 and 1882. Full-scale operational arc lamp; 15½"×6½"×21".

NMHT 251225; Accession 48865: patent model by N. S. Keith for U.S. Patent 255795 of 4 April 1882 (Figure 136); full-

115. *Ibid.*, pp. 349–351.

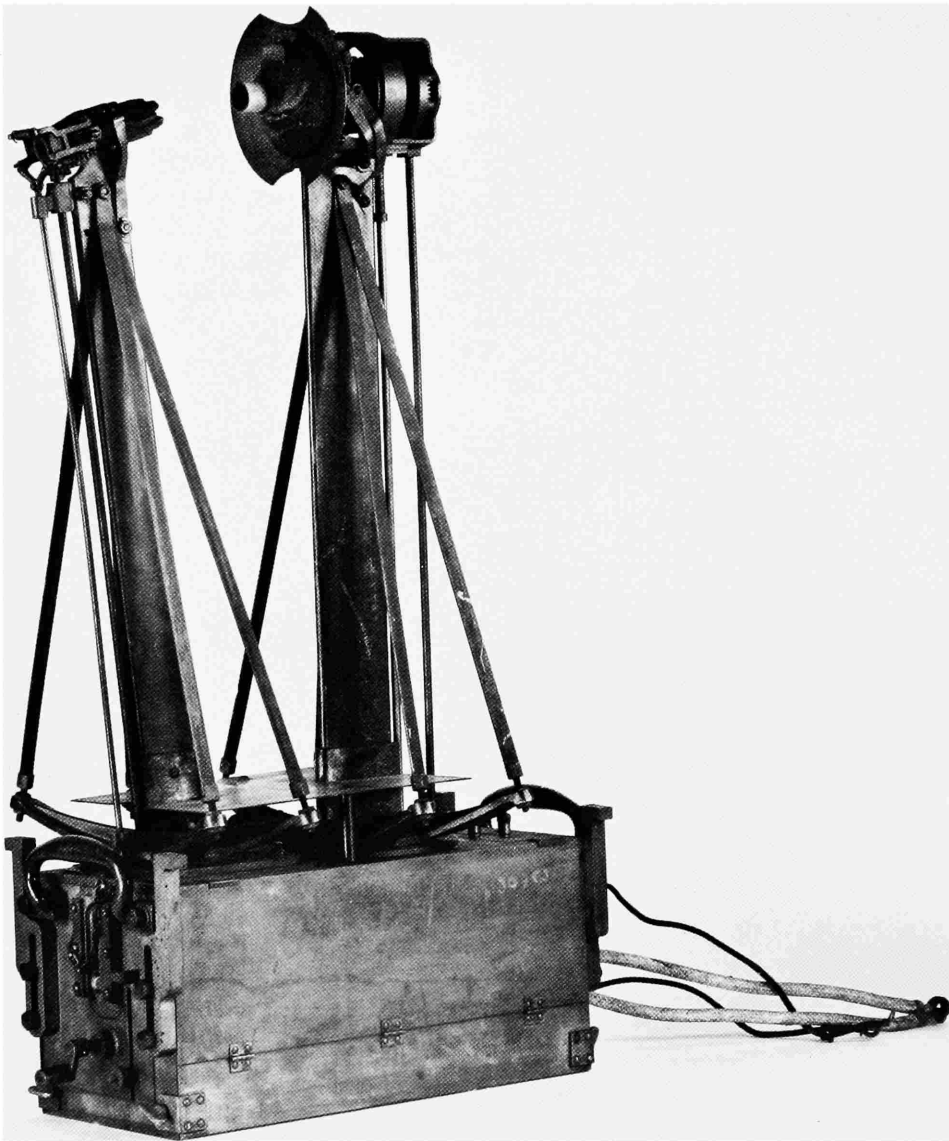

FIGURE 137.—Sperry high-intensity arc lamp, about 1918. (NMHT 309633. Smithsonian photo 60975-A.)

scale lamp, probably mass produced; 14" \times 5 $\frac{1}{2}$ " \times 30".

NMHT 251236; Accession 48865: patent model by Barton B. Ward for U.S. Patent 444472 of 13 January 1891 and 484479 of 18 October 1892. Full-scale lamp, probably taken from mass production; 8 $\frac{1}{2}$ " \times 4" \times 18".

NMHT 219017; Accession 40913: Adams-Bagnall Arc Lamp, late 1890s. Marked "The A.B.E. Co. Clev'd, O. Pat'd. Oct. 22, 95. No. B-7983." Production model, cutaway; 10" diameter \times 27" high.¹¹⁶

¹¹⁶ This lamp is shown on Figure 286, Crocker, *Electric Lighting*, II:352.

NMHT 309633; Accession 103045: Sperry high-intensity arc lamp (Figure 137), built about 1918. Marked "Sperry Gyroscope Co. New York. 150 Ampere-Search-Light Lamp. Mark 36-1 Mod. 1. Ser. No. 7 Insp'r—Patent Applied For." The lamp was developed in 1916 as a military searchlight. This unit is a duplicate of one used in 1924 by A. A. Michelson for his speed-of-light measurements on Mt. Wilson. The accuracy required from the control system for positioning the electrodes is unusually high, because the arc crater must always be in the focus of the reflector. The position of the arc is sensed by a thermostat pointed toward the focus. If the arc is not located correctly, the thermostat will sense a decrease in temperature and in response cause the repositioning of the electrodes. Size: $37'' \times 10'' \times 31\frac{1}{2}''$.¹¹⁷

117. Hughes, *Elmer Sperry*.

Feedback Control on Electric Machines

CONSTANT CURRENT REGULATION IN ARC-LIGHTING SYSTEMS.—Early systems of electric lighting, where a large number of arc lamps were powered by a common steam-driven DC generator, generally employed the series circuit. Experience had shown that individual arc lamps performed best at a potential drop of 40 to 50 volts and at a current between 6 and 10 amperes. The series circuit provided the best way of accommodating such operating requirements to the performance characteristics of the self-excited series generators then available. For example, a typical generator producing an electromotive force of 2000 volts at 10 amperes was then capable of supplying 40 arc lamps with current. Arc lamps, in general, proved to be highly sensitive to fluctuations in current. Particularly undesirable were rises in the line current occurring when some of the lamps in the

FIGURE 138.—Thomson-Houston current regulator, 1880. (NMHT 181725. Smithsonian photo 71888.)

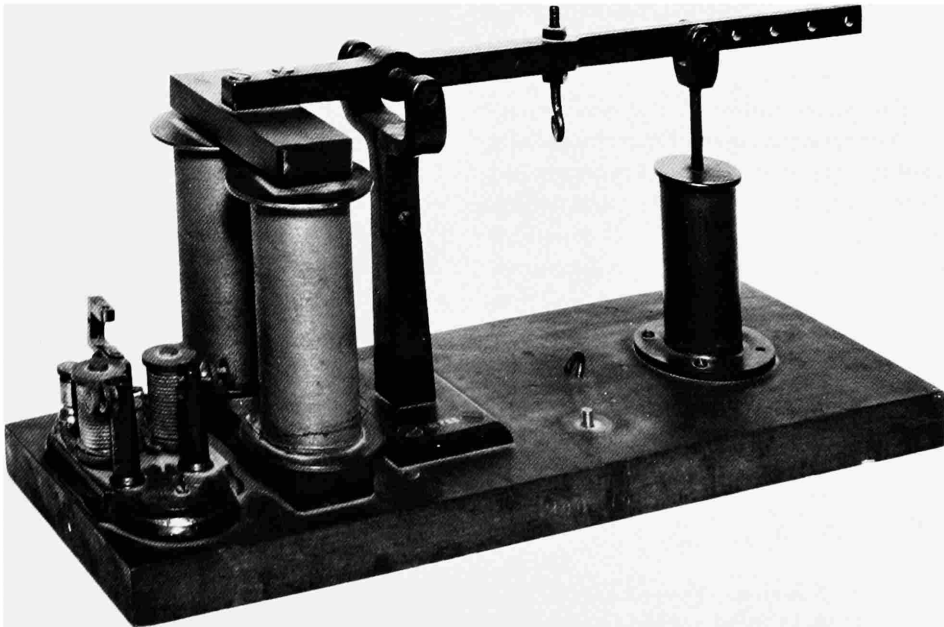

circuit, accidentally or purposely, went totally out of operation. To attain tolerably steady arc light, it became necessary to provide some form of automatic control that could maintain a constant current in spite of all disturbances.

The most successful current control system was that of Thomson-Houston, and it was largely upon this system that the early competitive advantage of that company was based. In our Museum it is represented by an early arrangement from 1880 (Figures 138–139) and two sets (one incomplete) of the maturer design of the late 1880s (Figures 140–142). In order to understand the functioning of this system, it is best to study the later version first.¹¹⁸

As Figure 142 shows, the system consists of three main parts: the generator with movable commutator brushes; the electromagnet *RA*; and the wall-mounted controller *ST*. The bottom of Figure 142 shows the DC generator with armature and field wired in series, equipped with two pairs of commutator brushes that can be rotated toward each other by a few degrees. When the distance between the positive and the negative brushes is thus reduced, the output electromotive force of the generator will decrease. The two pairs of brushes are connected by a lever so that they can be shifted simultaneously by a common linkage. This linkage is moved by the armature of the electromagnet *R*, whose pole is shaped paraboloidally to increase its operating range. Armature and magnet are connected by the dashpot, which has the function of arresting the armature whenever the electromagnet is deenergized. The current to the electromagnet *R*, in turn, is controlled by the solenoid *S* whose two coils are wired in series with the main circuit.

Normally the electromagnet is not energized. But whenever the line current becomes strong enough that the solenoid will attract its armature against the opposing spring force, the contact *T* will be closed, con-

necting the electromagnet into the main circuit. The magnet then will pull its armature upward and, by moving the commutator brushes closer, it will reduce the generator output, until the solenoid breaks contact at *T*. The resistance *r* merely serves to prevent sparks at *T*. It will be noticed that this system can only take corrective action against excessive currents. The system is laid out for a maximum number of arc lamps; disturbances that would increase this load, that is, decreasing the current, are unlikely.

A system exactly like the one just described, and dating probably from the late 1880s, is installed (Figure 140) on the Thomson-Houston DC generator, serial number 3634 (NMHT 328424; Accession 272928). Attached to it is part of the regulator (corresponding to *R* in Figure 142) inscribed "C¹² 3448," and carrying the following nameplate: "Automatic Regulator No. (blank); Patented Jan. 20, '80; Mar. 1, '81; Dec. 26, '82; Feb. 6, '83. Manufactured by Thomson Houston Electric Co., Lynn, Mass. U.S.A." The remaining part of this system (*ST* in Figure 142) is the wall-mounted controller (Figure 141) containing the solenoid (NMHT 328068; Accession 270107; marked "3284"; nameplate same as on previous regulator; in wooden box, 12"×5"×17"). Another Thomson-Houston current regulator, of the same type as the last, is incomplete. It consists of the electromagnet of the regulating system (NMHT 320573; Accession 241557; inscribed "E² 3549"; nameplate same as on previous regulators) mounted on a DC generator (NMHT 181720; Accession 33185; the commutator is defective). The wall-mounted box containing the solenoid that would complete the system is missing.

These two examples of the mature Thomson-Houston current regulator, where the control device is divided into two separate units, are contrasted by an early model of the regulator (Figure 138) dating from 1880 (NMHT 181725; Accession 33185). This earlier device works according to the same principle as the later design, but it combines all functions in a single compact unit, as described in E. Thomson's and E. J. Houston's

118. Silvanus P. Thompson, *Dynamo-Electric Machinery*, 4th edition (London, 1892), pp. 464–474; Crocker, *Electric Lighting*, I:333–335.

Patent 223659 of 20 January 1880 (Figure 139). The regulator was probably connected with a Thomson-Houston generator of 1879, also in the Museum's collection (NMHT 181727).

The Wood regulator used on the Gramme-type generators built by the Fort Wayne Electric Company is somewhat similar to the Thomson-Houston current control system. The Museum has a specimen of this

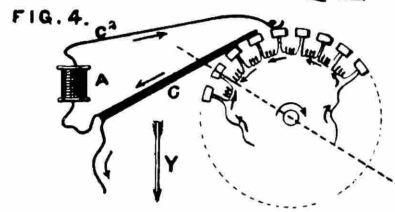
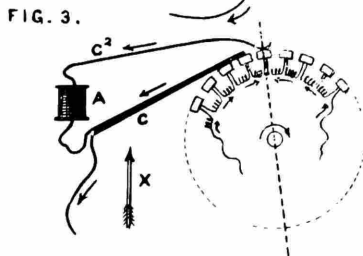
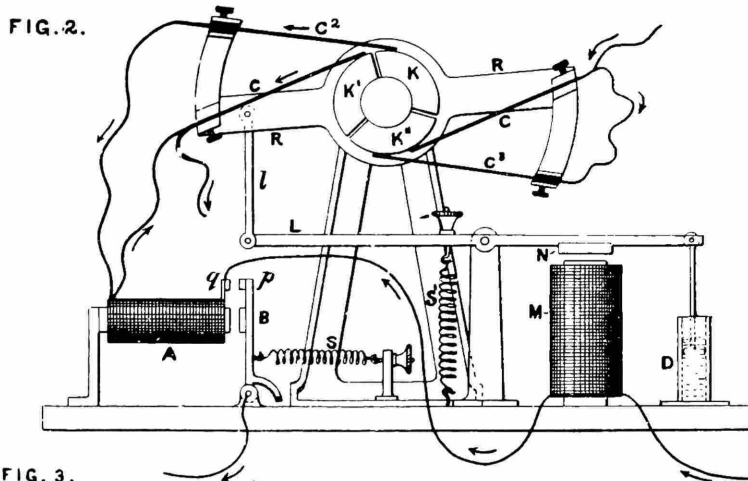
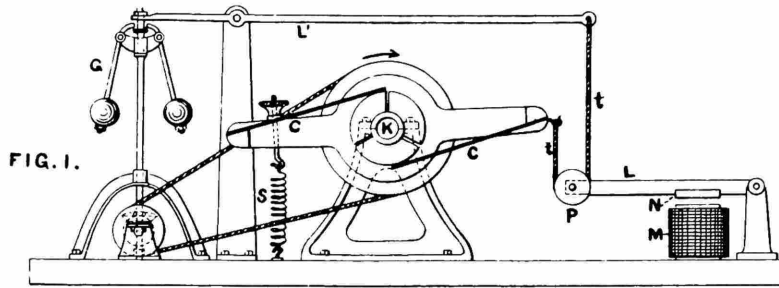

WITNESSES.

Geo. S. Richards
Osmond W. Fogdes

INVENTORS.

Edwin Thomson
Edwin J. Houston

FIGURE 139.—Various arrangements of current regulators, proposed by E. Thomson and E. J. Houston. The system of Figure 2 represents the current regulator of NMHT 181725. Reprinted from U. S. Patent No. 223659 of Jan. 20, 1880, Patent Specifications.

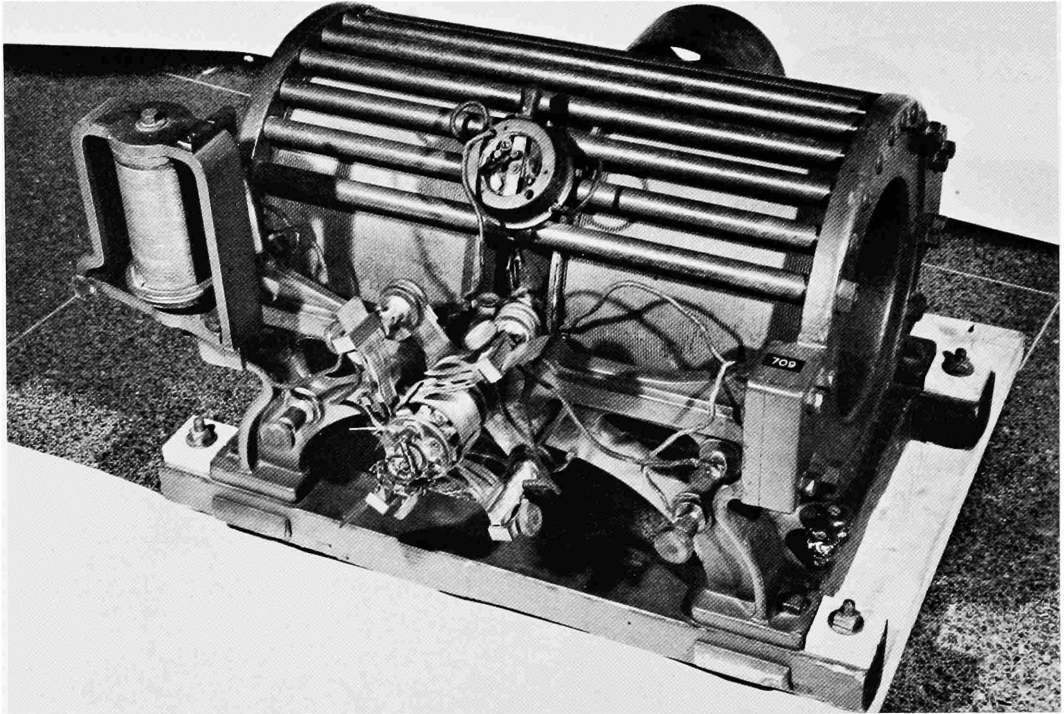

FIGURE 140.—Thomson-Houston D.C. generator with current regulator, late 1880s. (NMHT 328424. Smithsonian photo 74617.)

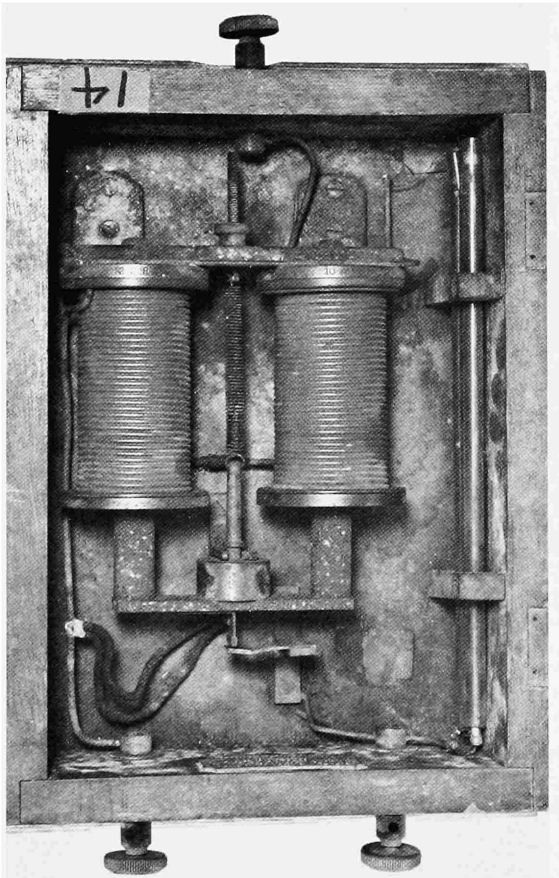
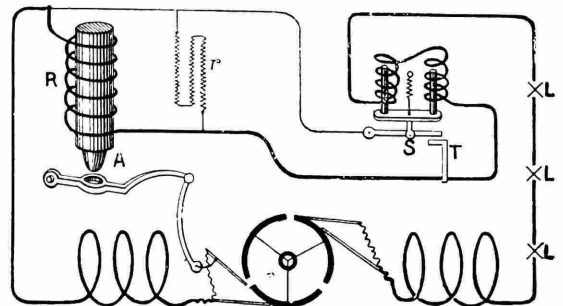

FIGURE 141.—Thomson-Houston wall-mounted current regulator. (NMHT 328068. Smithsonian photo 71879.)

FIGURE 142.—Circuit diagram of the Thomson-Houston current control system, as represented by NMHT 328424 and 328068. Reprinted from Silvanus P. Thompson, *Dynamo-Electric Machinery*, 4th ed. (London, 1892), fig. 315.



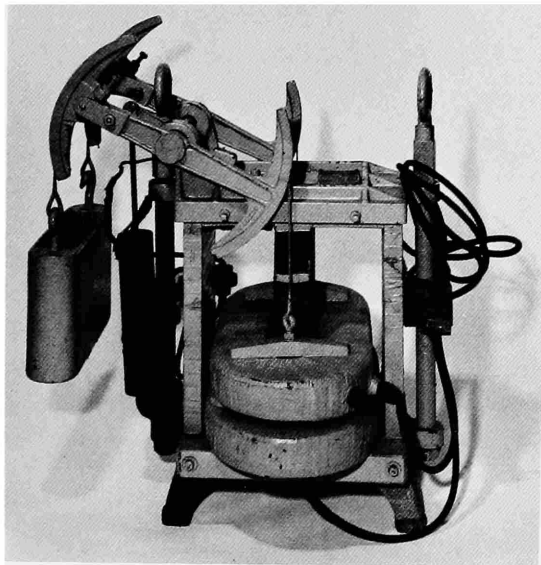

FIGURE 143.—G.E. constant current transformer, about 1905. (NMHT 326554. Smithsonian photo 74615.)

design identified by its nameplate as a "Wood Dynamo Electric Machine No. 5; Pat'd May, 1882; June 19, 1889; July 9, 1889; Dec. 31, 1889; Jan. 28, 1890; Feb. 11, 1890. Other Patents Applied For. No. 366" (NMHT 322247; Accession 205734). As in the Thomson-Houston system, an electromechanical regulator is used to shift the commutator brushes; the system differs in that the field consists of two exciting circuits wound differentially in opposite directions. The main circuit of these is connected in the usual fashion to a pair of fixed commutator brushes. The second one, however, is a demagnetizing circuit connected between one of the main brushes and a movable pilot brush manipulated by the regulator. As the current increases, the pilot brush moves away from the main brush, increasing the current passing through the demagnetizing circuit, and thus reducing the current output.¹¹⁹

At the end of the century, when *alternating current* was introduced into arc lighting, the basic series circuit was retained, and there-

fore it remained just as essential as before to keep the current in the line constant. Although a number of current regulators were proposed similar to those used on direct current, the *constant current transformer* soon was generally accepted for this task. In principle the regulating action of this transformer makes use of two phenomena: First, the primary and secondary coils of a transformer, if both carry current, repel each other with a force proportional to the currents. Second, the current induced in the secondary coil decreases with growing distance from the primary coil. A typical constant current transformer then is arranged as follows: The primary coil is attached horizontally to the lower part of the core. The secondary coil is suspended directly above it, balanced by counterweights, free to slide up or down along the core of the transformer. When the secondary current increases, the rise in electromagnetic repulsion will force the secondary coil to move up and away from the primary, thus reducing the secondary current and closing the feedback loop. The desired secondary current is determined by the weight of the counterpoises. In our Museum this transformer class is represented by a unit (Figure 143) built about 1905 by the General Electric Company (NMHT 326554; Accession 260953; Type RB-Form A-No. 502808; Primary 2200 volts, 60 cycles. Secondary 5.5 ampere, output at Unity Power Factor 8 kW).¹²⁰

SPEED CONTROL OF MOTORS.—Our collection has only one example of an electric motor in which the speed is controlled by a feedback device. The direct-current motor (Figure 144) marked "Max Kohl & Co., Chemnitz," dating from about 1900, was made for use in college physics laboratories by a well-known German supply house for laboratory equipment (NMHT 327873; Accession

119. Thompson, *Dynamo-Electric Machinery*, pp. 476, 774-776; Crocker, *Electric Lighting*, I:335-336.

120. Crocker, *Electric Lighting*, II:171-174; Jesse Berthold Gibbs, *Transformer Principles and Practice* (New York, 1937), pp. 131-138.

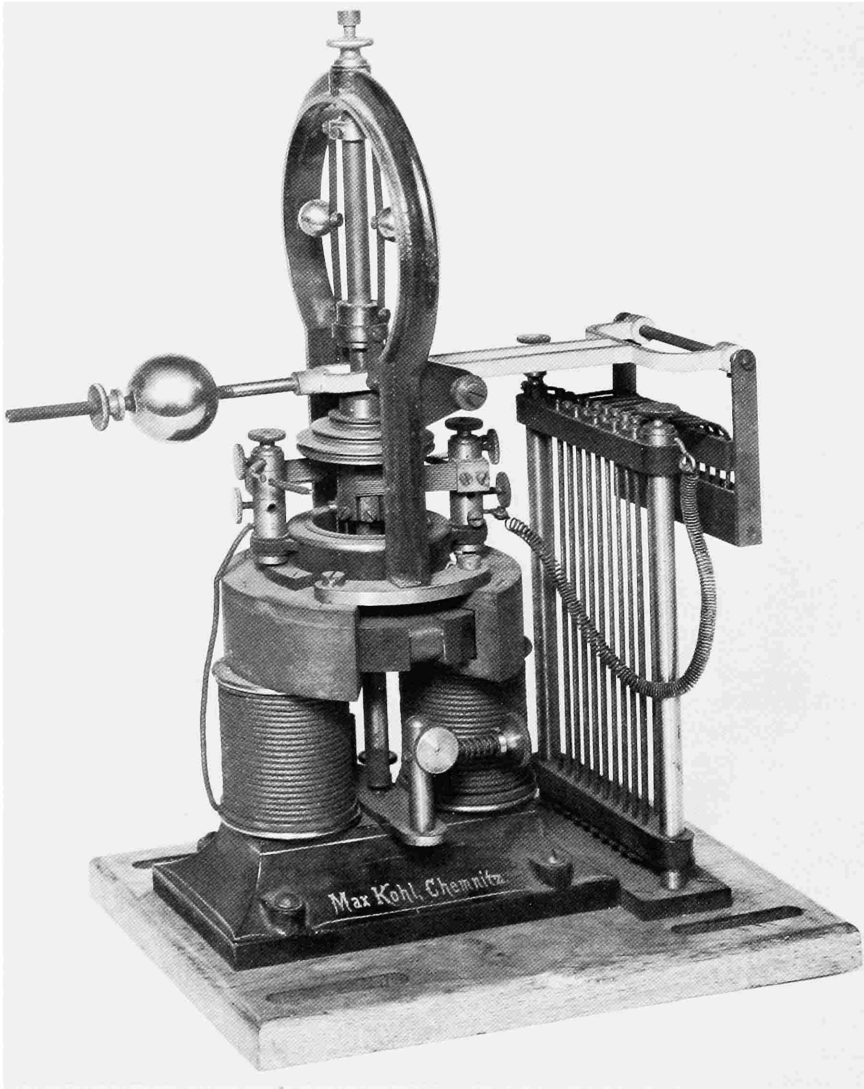

FIGURE 144.—Constant-speed D.C. motor by Max Kohl & Co., about 1900. (NMHT 327873. Smithsonian photo 71883.)

271855; $10'' \times 7\frac{1}{2}'' \times 15\frac{1}{2}''$). The speed is sensed in the traditional way by a centrifugal governor (of Pickering type) mounted on the motor axis. Corrective action is taken by varying a resistance which is connected in series with the two field coils and the armature of the motor. The mechanism employed is this: on the side of the motor, standing freely, is a row of vertical straight resistance wires, all arranged next to each other and connected in series. The top of each wire

carries an uninsulated spur with the end bent vertically downward, staggered in length. The governor output arm actuates a long lever with a counterweight on one end and a mercury trough at the other. This trough is suspended directly below the row of spurs, moving upward with decreasing speed. As more and more spurs are submerged in the mercury, a corresponding portion of the resistance is shortcircuited, with the effect of increasing the torque of the motor.

Electronic Computers

Analog Computers for Process Control Analysis

In the 1920s and 30s, a great deal of progress was made in the theoretical analysis of feedback control systems. One result was the discovery that many control processes, although occurring in totally different physical media, such as mechanical, thermal, hydraulic, or electrical processes, could be described mathematically by the same differential equations. If differences of coefficients were taken into account by adjustments of scale, such systems were dynamically equivalent. This meant that a control problem, given in a physical medium where experimentation was difficult, could be simulated and solved by analogy in a more manageable medium such as hydraulics or electricity.

George A. Philbrick (1913–) of Cambridge, Massachusetts, one of the pioneers in the field of analog computation, began to develop his electronic analyzer for control problems in 1936. The unit in our Museum (NMHT 327546; Accession 282961; 20"×18"×39") represents an early stage of his work (1938–40), but it incorporates all the basic features of modern analog computers (Figure 145). It is essentially the same as a device for which Philbrick received the U.S. Patent 2503213 on 4 April 1950 (application filed on 21 December 1946).

The analog computer represents the complete feedback loop, process as well as controller. The simulated system consists of a pneumatic three-response controller (proportional, derivative, integral) employed to

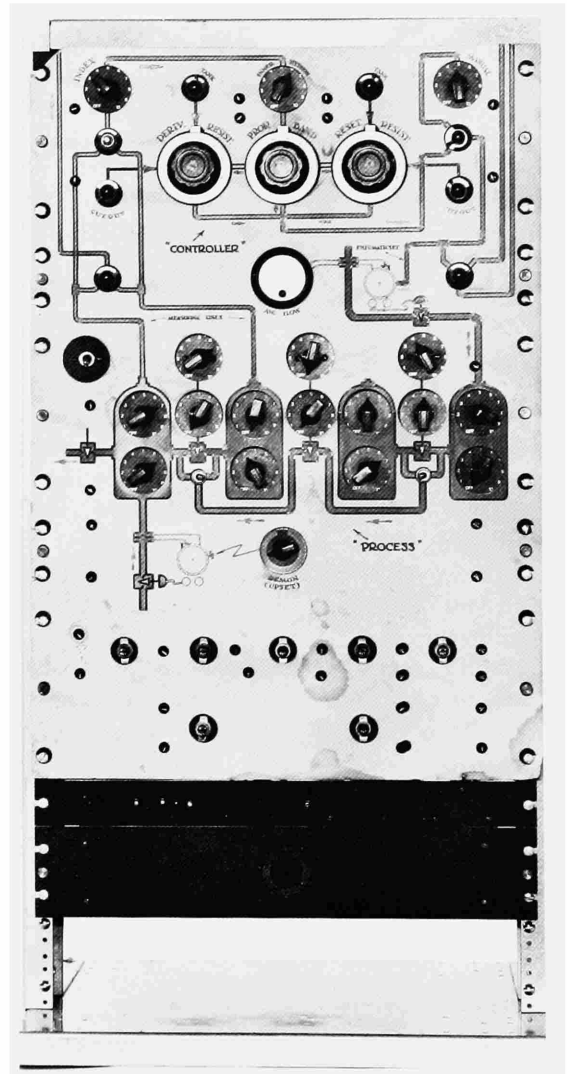

FIGURE 145.—Philbrick electronic analog computer for feedback control system analysis. (NMHT 327546. Smithsonian photo 61757-A.)

maintain a constant level in a tank containing a liquid. In addition, the process includes three resistance-capacitance elements, to represent time constants, connected in series ahead of the tank. This hydraulic system, of course, can also easily be translated into the terms of a mechanical, thermal, or pneumatic process, as found in actual practice. The controlled variable in the hydraulic process, the liquid level, is represented electrically by a voltage, and the flow of liquid into this tank by a current. The controller is simulated by a combination of several vacuum tube amplifiers.

The control problem to be solved is to adjust the parameters of the controller for optimum behavior of the controlled variable in the event of uncontrollable outside disturbances. This is done empirically: the operator introduces disturbances, watches the controlled variable by means of an oscilloscope, and adjusts the controller parameters, until the system responds to disturbances in the manner of a strongly attenuated sine wave. An obvious problem is that the electronic system responds far more rapidly than a nonelectric process. This is solved by introducing the disturbances repeatedly in rapid succession, at the same frequency as that of the horizontal sweep of the oscilloscope beam. The sine curve on the screen thus appears stationary.

Analog computers such as this one have come to play an important part in modern engineering, as an instrument in solving actual problems, and as an incomparable educational tool.

Digital Process Control Computer

In a sense every conventional feedback controller is an analog computer. A three-response controller (proportional, integral, derivative), for example, as the most general type, is programmed to solve the equation

$$\text{output} = K \left(e + k_1 \int e \, dt + k_2 \frac{de}{dt} \right)$$

(where e = desired variable – controlled variable), while the other controller types solve simplified versions of this equation. Complicated chemical processes, however, comprise a great number of such feedback loops controlling variables like pressure, temperature, level, and flow rate, which are all interrelated by definite laws depending on the process. Special digital computers have therefore been developed that not only replace in a single unit all the conventional controllers used before, but are capable also of optimizing the performance of the overall system by coordinating the individual control loops in a unified manner.

The Ramo-Wooldridge RW-300 reportedly was the first digital computer ever used on closed-loop process control (put into operation on 13 March 1959 on a Texaco refinery at Port Arthur, Texas). The unit in the Museum, serial number A8, is an exact duplicate of this computer. (Accession L 282964; size of the computer proper: 56" × 29" × 36"; input-output cabinet: 24" × 24" × 83"). It was employed to control an ammonia process at the Luling, Louisiana, plant of the Monsanto Co. Since the computer functions in a digital language, while the measuring instruments and control devices of the process communicate in analog signals, a separate input-output unit serves as interpreter between the process and the computer. In contrast to analog controllers, the digital computer operates not continuously but intermittently. It samples all process variables at regular intervals, calculates on this basis the required control signals, and, if necessary, causes corrective action. The sampling intervals, chosen according to the needs of the process, range in length between a few seconds and several minutes.¹²¹

¹²¹ "Computer Runs Refinery Unit in Texas," *Business Week* (4 April 1959); A. L. Giusto, R. E. Otto, T. J. Williams, "Digital Computer Control," *Control Engineering* (June 1962).

Location Guide

The following list gives the location of the cataloged specimens roughly at the beginning of 1970. Changes occur, of course, continuously. The locations listed here, unless marked otherwise, are to be found in the National Museum of History and Technology. The Initials S.H. refer to the Silver Hill storage facility in Suitland, Maryland. Open exhibits are in italics. Exhibits identified by asterisk are in preparation and not yet opened to the public.

<i>NMHT No.</i>	<i>Specimen</i>	<i>Location</i>
58 A6	Avery "Bulldog" tractor	S.H. Bldg. 17
58 A9	Frick "Eclipse" portable steam engine	S.H. Bldg. 17
60 A74	Hart-Parr tractor	<i>Hall of Agriculture</i>
62 A10	J. I. Case portable steam engine	<i>Hall of Agriculture</i>
67 A2	J. Deere "Waterloo Boy" tractor	<i>Hall of Agriculture</i>
T-8571	Draper "Northrop" loom	Hall of Textiles*
T-11411	G. Richardson, let-off mechanism (pat. model)	4509
T-11412	R. Walker, let-off mechanism (pat. model)	4509
T-11421	S. J. Whitton, drawing-frame regulator (pat. model)	4509
31113-N	Howell torpedo	S.H. Bldg. 15
31114-N	Whitehead torpedo	S.H. Bldg. 15
31115-N	Bliss-Leavitt torpedo	S.H. Bldg. 15
31155-N	German torpedo	S.H. Bldg. 15
39596-N	Sperry gyrocompass	S.H. Bldg. 15
53774-N	Howell torpedo	Hall of Armed Forces*
58761-N	MK 37 (USA) torpedo	S.H. Bldg. 15
58762-N	Japanese torpedo	S.H. Bldg. 15
58763-N	Japanese torpedo	S.H. Bldg. 15
1015	Bell & Tainter graphophone	<i>Hall of Light Machinery</i>
180024	F.E. Sickels steering engine	S.H. Bldg. 17
180029	J. Stevens safety valve	<i>Hall of Railroads</i>
181554	C.F. Brush arc lamp	5001
181725	Thomson-Houston current regulator	Hall of Electricity*
181973	M.G. Farmer, arc lamp regulator	5001
181974	M.G. Farmer, arc lamp regulator	5001
201363	W. Wallace arc lamp	5001
201365	Wallace-Farmer arc lamp	Hall of Electricity*
202871	Edison phonograph	<i>Hall of Light Machinery</i>
219016	Thomson-Rice arc lamp	5001
219017	Adams-Bagnall arc lamp	5001
251222	C.J. Van Depoele arc regulator (pat. model)	5001
251223	M. Day, arc lamp (pat. model)	5001
251225	N.S. Keith, arc lamp (pat. model)	5001
251227	C.J. Van Depoele, arc regulator (pat. model)	5001
251230	C.F. Bush, arc lamp (pat. model)	Hall of Electricity*
251232	C.F. Brush, arc lamp (pat. model)	5001

<i>NMHT No.</i>	<i>Specimen</i>	<i>Location</i>
251233	Thomson-Houston arc lamp	Hall of Electricity*
251236	B.B. Ward, arc lamp (pat. model)	5001
251287	Stearns & Hodgson governor (pat. model)	<i>Hall of Power</i>
251288	H.A. Luttgens, governor (pat. model)	<i>Hall of Power</i>
251289	C.T. Porter, governor (pat. model)	<i>Hall of Power</i>
251290	D.A. Woodbury, governor (pat. model)	<i>Hall of Power</i>
252595	F.E. Sickels, steering engine (pat. model)	5006
252596	F.E. Sickels, steering engine (pat. model)	5006
252616	T.A. Edison, printing telegraph (pat. model)	5001
252617	T.A. Edison, multiplex telegraph (pat. model)	5001
252649	C.F. Brush, arc lamp (pat. model)	5001
252652	C.J. Van Depoele, arc regulator (pat. model)	5001
252655	H.S. Maxim, arc lamp (pat. model)	5001
252656	H.S. Maxim, arc lamp (pat. model)	5001
252660	E. Weston, arc lamp (pat. model)	5001
253757	Berliner-Clark gramophone	<i>Hall of Light Machinery</i>
261315	centrifugal pendulum	5400
307254	Autocar gasoline engine	<i>Hall of Automobiles</i>
308218	1923 Cadillac chassis	S.H. Bldg. 19
308479	A.L. Dyke carburetor	5006
308559	J. Gates, steering apparatus (pat. model)	5006
308597	C.J. Van Depoele, arc regulator (pat. model)	5001
308598	C.J. Van Depoele, arc regulator (pat. model)	5001
308646	G.H. Corliss, steam engine (pat. model)	<i>Hall of Power</i>
308667	Kelley & Lamb, governor (pat. model)	<i>Hall of Power</i>
308678	A.J. Peavey, governor (pat. model)	5400
308700	Thompson & Hunt, governor (pat. model)	<i>Hall of Power</i>
308713	Kipp & Murphy, pressure regulator (pat. model)	5400
308715	G.H. Corliss, governor (pat. model)	5400
309236	G.H. Corliss, pressure regulator (pat. model)	5400
309242	J. Reid, governor (pat. model)	5400
309243	J.G. Bodemer, governor (pat. model)	<i>Hall of Power</i>
309244	Judson & Cogswell, governor (pat. model)	5400
309279	C.C. Lloyd, gas regulator (pat. model)	CB-069
309497	1902 White steam automobile	<i>Hall of Automobiles</i>
309549	1912 Simplex automobile	<i>Hall of Automobiles</i>
309556	Schleicher-Schumm "Silent Otto" engine	S.H. Bldg. 17
309639	1900 Locomobile steam car	<i>Hall of Automobiles</i>
309633	Sperry arc lamp	5001
309634	Sperry Gyropilot	S.H. Bldg. 17
309636	Sperry Gyrocompass	Hall of Marine Transportation*
309637	Hornsby-Akroyd oil engine	<i>Hall of Power</i>
309817	Corliss cut-off governor	5400
309818	Corliss throttle governor	5400
309820	Corliss steam engine, model	CB-069
309881	G.E. steam turbine (1927)	<i>Hall of Power</i>
309924	Westinghouse "Junior Automatic" steam engine	S.H. Bldg. 17
310241	"U.S. Military Dept." steam engine	S.H. Bldg. 17
310289	Pickering governor (1880s)	<i>Hall of Power</i>
310290	Pickering governor (1931)	5400
310371	Atkinson "Cycle" gas engine	<i>Hall of Power</i>
310474	Wadsworth steering engine, model	5006
310475	Wadsworth steering engine, model	5006
310476	Wadsworth steering engine, model	5006
311017	Bosch fuel injection pump	5400
311052	Ford Model T automobile	<i>Hall of Automobiles</i>
311875	Parsons steam turbine	<i>Hall of Power</i>
311902	Otto gas engine	<i>Hall of Power</i>

<i>NMHT No.</i>	<i>Specimen</i>	<i>Location</i>
311991	Reynolds-Corliss steam engine, model	CB-069
312822	Bantam Army Jeep	S.H. Bldg. 19
312825	Bosch fuel injection pump	<i>Hall of Power</i>
313403	Sperry Gyrocompass	S.H. Bldg. 15
313703	Brayton oil engine	<i>Hall of Power</i>
314511	Hendey steam engine	<i>Hall of Power</i>
314522	Davis automobile power steering	5006
314658	Otto & Langen gas engine	<i>Hall of Power</i>
314791	Harlan & Hollingsworth steam engine	<i>Hall of Power</i>
314818	Corliss-Naylor steam engine	<i>Hall of Power</i>
314820	Terry steam turbine	<i>Hall of Power</i>
314822	Baldwin steam engine	<i>Hall of Power</i>
314843	De Laval steam turbine	<i>Hall of Power</i>
314888	Abbot chronograph governor	5120
314945	M.A.N. Diesel engine	<i>Hall of Power</i>
314989	graphophone	<i>Hall of Light Machinery</i>
315042	Lenoir gas engine	<i>Hall of Power</i>
315111	Olds gasoline engine	S.H. Bldg. 17
315243	chronograph	<i>Hall of Astronomy</i>
315438	Cryer vacuum regulator	5400
315708	Allis-Chalmers hydraulic servo governor	S.H. Bldg. 17
315709	Allis-Chalmers governor	S.H. Bldg. 17
315712	Shipman steam engine	<i>Hall of Power</i>
315717	Foucault-Duboscq arc lamp	5001
315858	Woodward type-L.R. governor	CB-069
315891	Porter-Allen steam engine	<i>Hall of Power</i>
315896	Woodward type-3 governor	<i>Hall of Power</i>
315897	Woodward type-UG8 governor	<i>Hall of Power</i>
316013	Greene steam engine, model	<i>Hall of Power</i>
316096	Telescope clockwork	5120
316139	Bancks steam engine, model	<i>Hall of Power</i>
316276	chronograph (German)	5120
316578	Atlas-Imperial Diesel engine	<i>Hall of Power</i>
316656	Arco damper motor	5400
316657	Honeywell thermostat	5400
316658	Honeywell aquastat	5400
316726	"American" Diesel engine	<i>Hall of Power</i>
316806	Aermotor gasoline engine	S.H. Bldg. 17
318011	Rodney Hunt governor	CB-069
318170	Otis elevator engine	S.H. Bldg. 17
318460	Judson governor	5019
319024	Buick gasoline engine	<i>Hall of Power</i>
319243	Frick refrigerator compressor	<i>Hall of Power</i>
319279	Siemens arc lamp	5001
319405	Holloway steam engine	<i>Hall of Power</i>
319407	Mietz & Weiss oil engine	S.H. Bldg. 17
319477	Skinner "Unaflow" steam engine	<i>Hall of Power</i>
319765	Siemens & Halske printing telegraph	5001
320000	Southern Railway Locomotive	<i>Hall of Railroads</i>
320023	I.R.T. steam engine generator, model	<i>Hall of Power</i>
320136	Lombard type-F governor	CB-069
320331	Woodward type-D governor	S.H. Bldg. 17
320573	Thomson-Houston D.C. generator	Hall of Electricity*
321454	1924 Franklin automobile	<i>Hall of Automobiles</i>
321888	W. Yates, governor (pat. model)	5400
322000	Parsons steam turbine	<i>Hall of Power</i>
322247	Gramme-Wood D.C. generator	CB-069
322259	steam engine, model (Johns Hopkins U.)	<i>Hall of Power</i>

<i>NMHT No.</i>	<i>Specimen</i>	<i>Location</i>
322282	telescope clockwork, G. Boulitte	5120
322455	chronograph	5120
322556	Westinghouse compound steam engine	<i>Hall of Power</i>
322557	Ball steam engine	S.H. Bldg. 17
322560	Mack model AC truck	<i>Hall of Automobiles</i>
323494	James Watt steam engine, model	<i>Hall of Power</i>
323495	"Silent Otto" gas engine	<i>Hall of Power</i>
323518	American-La France fire truck	S.H. Bldg. 17
323569	1918 Oldsmobile automobile	S.H. Bldg. 19
323697	Otto gas engine	S.H. Bldg. 17
323716	Holloway steam engine, model	<i>Hall of Power</i>
324000	Hermany-Leavitt steam engine, model	<i>Hall of Power</i>
325525	Waters governor	5400
325611	T. Silver, governor (pat. model)	5400
325612	H.N. Throop, governor (pat. model)	5400
325613	G.H. Miller, governor (pat. model)	5400
325614	T.S. La France, governor (pat. model)	5400
325615	J. Knowlson, governor (pat. model)	5400
325664	Harrisburg steam engine, model	5400
325904	White & Middleton gasoline engine	S.H. Bldg. 17
325905	Baxter steam engine and boiler	CB-069
325908	steam engine, model (Jerrehian)	<i>Hall of Power</i>
325989	Brush arc lamp	5001
326151	1917 White bus	<i>Hall of Automobiles</i>
326222	1912 Pierce-Arrow automobile	<i>Hall of Automobiles</i>
326536	Jarecki "Erie" compressor governor	CB-069
326554	G.E. constant current transformer	CB-069
326619	Weber-Thomas vacuum oven	5120
326987	Wiechert seismograph	<i>Hall of Physics</i>
327546	Philbrick electronic analog computer	<i>Hall of Mathematics</i>
327675	Corliss steam engine, model	<i>Hall of Power</i>
327711	telescope clockwork (Princeton)	CB-069
327873	D.C. motor with speed regulation	5001
327945	street arc lamp	CB-069
327946	Brush street arc lamp	CB-069
327954	Siemens & Halske printing telegraph	CB-069
328068	Thomson-Houston current regulator	5001
328394	Lorimer gasoline engine	S.H. Bldg. 17
328424	Thomson-Houston D.C. generator	Hall of Electricity*
328660	Linde-Wolf refrigeration compressor	American Brewery, Baltimore, Md.
328723	Willans compound steam engine	S.H. Bldg. 17
328889	chronograph governor	5120
329211	Corliss steam engine, model	5400
329286	Packard winterfront	<i>Hall of Automobiles</i>
329758	Gardner governor	5400
329792	"Domestic" gasoline engine	<i>Hall of Power</i>
330028	Marquette governor	5400
330029	Woodward type-SI governor	5400
loan	Bunker-Ramo digital process control computer	<i>Hall of Mathematics</i>

Index

- Abbott, C. G., clockwork by, 66
Adams-Bagnall arc lamp, 118
"Aermotor" gasoline engine, 54
Airy, George Biddell, 64
Albion Mill, 4
Allen, John F., positive cutoff gear by, 14
Allis-Chalmers Co., hydraulic servo regulator by, 16
American Bosch fuel injector, 60
American Diesel Engine Co., 56
analog computer for process control analysis, 125-126
arc lamps, regulation of, 105-119
"astatic" governors, 6
Atkinson "Cycle" gas engine, 55
Atlas-Imperial marine Diesel engine, 60
Autocar Heavy Duty engine, 87
automatic cutoff control, general, 7-13
 detachable, or drop-off, 8, 14
 positive, 8, 14, 17, 33
Avery Bulldog Tractor, 86
- Baldwin, Mathias W., steam engine by, 6
Ball, Frank H., 35, 37
Bartlett let-off mechanism, 81
Baxter combination steam engine, 30
Bell & Tainter graphophone, 68
Berliner Gramophone, 68
Bliss, E. W., & Co., 97, 99
Bodemer, Johann Georg, water turbine governor by, 26
Boesch model steam engine, 35
Bosch fuel injection pumps, 60-61
Boulitte, G., clockwork built by, 65
Boulton, Matthew, 4
Boulton & Watt, 4, 6, 74
Brayton oil engine, 55
Brush, Charles F., 107
Brush Electric Light Co., 14
 lighting system of, 107-111
Buckeye Engine Company, 34
Buick gasoline engine, 49
- carburetors, float-feed, 89-90
Case, J. I., portable steam engine by, 28
centrifugal governor, 4-69, 86-88, 123-124
 invention of, 4
centrifugal pendulum, 3
chronographs, 64-65
Clark, Alfred C., 68
clockwork for telescopes, 64-65
closed loop control, see feedback control
Cogswell, William A., 27
Columbia Phonograph Co., 68
compass, gyroscopic, 101-102
- "compensating" governor, 42-43
compressor governor, 32
computers, electronic, 125-126
 analog, 125-126
 digital, 126
Corliss, George Henry, 8, 9, 10, 11, 24, 74
Cryer, T. B., Co., 76
current regulation, 10-92, 118-123
Custer, Jacob D., 33
- Davis, Francis Wright, 92
Day, Matthias, 106
Deere, John, Co., 86
de Laval, Gustav, 48
depth-control system for torpedoes (immersion regulator), 97, 100
derivative response, governor with proportional plus, 19, 33
Diesel engine, speed regulation of, 56
"differential" circuit for arc lamps, 110-112
digital process control computer, 126
"Domestic" gasoline engine, 53
drawing-frame for cotton, 82
Drebbel, Cornelis, 3, 77
Dubosq, Jules, 105, 106
Dyke, A. L., float-feed carburetor by, 89
- Edison, Thomas A., 68, 69
Edison's phonograph, 68
electronic devices, feedback in, 105 fn
Elektrosignal G.m.b.H., 65
- Farmer, Moses G., 111, 112
Fauth & Co., chronograph by, 65
Fecker, John W., 23-inch refractor built by, 65
feedback control, definition, 1-2
feedback devices, origins, 2-3
feedback on servomotors, 42, 44
float valve level regulator, 2-3, 70-72, 89-90
Foucault, Léon, 101, 105, 106
Frick "Eclipse" portable steam engine, 30
friction governors, 64-69
fuel injection pumps, 56-61
- Gardner Governor Company, 30, 31
gas meter, 73
Gasmotoren-Fabrik Deutz, 50
Gates, John, 96
General Electric Company, constant current transformer, 123
 Curtis steam turbine, 49
Gibbs, Charles E., 39

- Greene, Noble T., model of steam engine, 11, 13
 "gust"-governing, 47-48
 gyropilot, 102-104
 gyroscopes in torpedoes, 99-100
 gyroscopic compasses, 101-102
 gyroscopic governor, 26
- Hancock Inspirator Co., 75
 Harlan & Hollingsworth steam engine, 7
 Harrisburg Foundry and Machine Co., 34
 Hart-Parr agricultural tractor, 53
 Hendey, Henry J., rotary steam engine by, 28
 Heron of Alexandria, 2
 high-speed steam engine, 13-15
 "hit-and-miss" governing, 50, 53-54
 Holloway, Thomas, steam engine by, 6
 Honeywell Heating Specialties Co., 77-78
 Hornsby-Akroyd hot-bulb oil engine, 55
 Howell, John Adams, 99
 Howell torpedo, 99-100
 Hughes-type printing telegraph, 69
 Hunt, Nathan, shaft governor by, 34
 Hunt, Rodney, waterwheel governor by, 39, 42
 hydraulic governors, 21-24, 87
- immersion regulator, 97, 100
 inertia governor, 19, 34-38
 integral response, control with, 17, 20, 42, 62, 63
 "isochronous" governors, 6, 62
- Jarecki Manufacturing Co., compressor governor by, 32
 Jerrehian toy steam engine, 28
 Judson, Junius, 27, 28
- Keith, N. S., 117
 Kelley, Oliver A., and Estus Lamb, steam engine governor by, 20
 Kipp, A., and H. Murphy, pressure regulator by, 74
 Knowlson, John, steam engine governor by, 25
 Ktesibios of Alexandria, water clock of, 2
- LaFrance, T. S., steam engine governor by, 21
 "Lap" engine, 4, 5
 Leavitt, Erasmus D., steam pumping engine by, 16
 Lenoir gas engine, 49
 let-off mechanisms for power looms, 79-81
 Lloyd, Charles E., 73
 "Locomobile" steam automobile, 83-86
 Lombard Governor Co., 44
 looms, power, 79-81
 Lorimer gasoline engine "Sturdy Scott," 49
 Luttgens, H. A., governor by, 16
- Mack "Bulldog" truck, 87
 M.A.N. Diesel engine, 56
 Marquette Metal Products Co., 62
 Mason Regulator Co., 24
 Maxim, Hiram S., 117
 Maybach, Wilhelm, 89
- Mietz & Weiss hot-bulb oil engine, 55
 Miller, S. H., steam engine governor by, 20
- "Nautilus," submarine, 102
 Naylor, Jacob, steam engine by, 10, 11, 12
 Northrop loom, 80-81
- Obry, Ludwig, 99
 Olds gasoline engine, 54
 Otto gas engine, 50, 53
- Packard "Winterfront," 88
 Papin, Denis, safety valve of, 3, 70
 Parsons, Charles A., 45-47
 patent models of governors, 16-27
 Peavey, Andrew J., hydraulic vane governor by, 21
 Pharo Manufacturing Co., governor by, 87
 Philbrick, George A., 125
 phonographs, 66-69
 Pickering, Thomas R., spring governor by, 28-31
 Pierce Governor Co., 50
 Porter, Charles T., "loaded" governor by, 13-16
 Porter-Allen high speed steam engine, 14, 15, 16
 power steering, automobile, 92
 pressure regulator, 70, 72, 73-76, 83, 86, 90, 97
 proportional control, 4, 6, 17, 43, 50, 55
 proportional offset, 6
- railway technology, feedback control in, 83
 Ramo-Wooldridge computer, 126
 Reid, Joseph, gyroscopic governor by, 26
 Rennie, John, 4
 Reynolds-Corliss engine, model of, 11
 Richardson, George, 80
- safety valve, 3, 70, 72
 Schleicher, Schumm & Co., 53
 Scholfield, N., governor by, 39
 servo governors, mechanical, 39
 servomotor, hydraulic, 16, 43, 92
 servomotor, pneumatic, 97, 99
 servo steering, ships, 93-96
 shaft governor, 33-38, 54, 68, 72
 Shipman "Automatic" steam engine, 34, 70-72
 "shunt" circuit for arc lamps, 112
 Sickels, Frederick E., 8, 11, 93
 Siemens-von Hefner Alteneck arc lamp, 106
 Siemens & Halke telegraph, 69
 "Silent Otto" gas engine, 50
 Silver, Thomas, marine steam engine governor by, 18
 Skinner "Universal Unaflo" steam engine, 38
 speed control of electric motors, 123-124
 speed governors on trucks and tractors, 86-88
 Sperry, Elmer A., 101-104
 Sperry high-intensity arc lamp, 119
 Spindler & Hoyer, Göttingen, 65
 steam automobiles, 83-86
 steam boilers, automatic control of, 70-72
 steam steering gear, 93-96
 Stearns, G. S., and W. Hodgson, governor by, 17-18

- Stevens, John, 70
 Sulzer Brothers, Winterthur, Switzerland, steam engine by, 15
- telegraphs, 69
 telescope regulators, 64-65
 temperature regulation, 3, 77-78, 86, 88-89
 Terry steam turbine, 49
 textile machinery, feedback control on, 79-82
 thermostat, see temperature regulation
 Thompson-Hunt shaft governor, 34
 Thomson-Houston current control system, 120-121
 Thomson-Houston electric lighting system, 112
 Thomson-Rice double arc lamp, 112
 Throop, H. N., marine steam engine governor by, 19, 33
 Thurston, Benjamin Francis, 11, 13
 torpedoes, feedback control in, 96-101
 transformer, constant current, 123
 Troughton & Simms, equatorial telescope, 64
- Ure, Andrew, 3, 77
- vacuum regulator, 76
 Van Depoele, Charles J., 117
 voltage regulation, 90-92
 Wadsworth, Herbert, 96
- Walker, Richard, 80
 Wallace, William, 111
 Wallace-Farmer electric lighting system, 111-112
 Wamsutta Mills, New Bedford, Mass., 8
 Ward, Barton B., 118
 "Waterloo Boy" tractor, 86
 Waters, Charles, steam engine governor by, 30
 waterwheel governors, 39
 Watt, James, 3, 4-6
 Weber, electric vacuum oven, 78
 Westinghouse, Henry Herman, 35
 Westinghouse air pressure regulator, 83
 Westinghouse "Automatic" compound steam engine, 35
 Westinghouse "Junior Automatic" engine, 35
 Weston, Edward, 117
 White steam automobile, 86
 White & Middleton gasoline engine, 53
 Whitehead, Robert, 96-99
 Whitton, Samuel J., 82
 Wiechert, seismograph, 65
 Willans central-piston compound, engine, 33
 Wood regulator on Gramme-type generator, 121-123
 Woodbury, Daniel A., 33
 Woodward, Amos, 40
 Woodward, Elmer E., 40-42
 Woodward Governor Co., 44-45, 61-63
- Yates, William, steam engine governor by, 24